

# HALL CONSTRUCTION PRODUCTS AND SERVICES

P. O. Box 1392, South Glens Falls, NY 12803

(518) 747-7047

## DURASLOT® Drains - Shipping & Handling

Most DURASLOT orders ship LTL from the HCPS plant in Hudson Falls, NY, zip: 12803. The majority of these orders consist of only one size of pipe. For this type of order HCPS will bundle the ten foot lengths into groups of 2-5 pieces, weighing from 65# - 155# (5 pcs. of 4" - 3 pcs. of 12"). Pipe of 15" diameter or larger is shipped individually. These orders generally arrive in a box trailer and are best unloaded by hand - two men can easily handle all bundles.

The bundles are held together by tie wire which is sandwiched between two layers of duct tape to protect the plastic pipe. The customer should be aware that the tape will not tear; the wire needs to be cut. When pipe is sent LTL, the fittings and hardware are generally sent UPS. These will usually arrive a day or two before the pipe. The UPS package(s) will have all the paperwork (packing list, copy of the bill of lading, order copy, assembly details, and installation notes) except the original bill of lading which comes with the pipe.

For orders with more than one pipe size (example- dealer stock), when possible, HCPS will nest smaller pipe in larger pipe. As this starts to get heavy, we will build a pallet or skid which allows the customer to unload by forklift. Some fittings may be included on the pallet, but generally fittings and hardware will still go UPS. The paperwork will be in the UPS box; the customer should be reminded to keep the order copy to check against the material on the pallet(s) or skid(s) when it arrives.

**For Truckload Deliveries:** When an order for a truckload of DURASLOT is loaded, all fittings and hardware goes with that truck. The fittings are generally strapped to the upper level of a step-deck trailer, and the hardware is boxed separately. The pipe will be stacked in four piles, ten feet long on 4" x 4" cross pieces. These allow nylon slings to be slid under the stack and wrapped around it. The whole 10-foot pile can be unloaded by a crane or any machine that can use the nylon slings to lift the pile off the truck. Metal chains or any other material which could damage the pipe are not recommended for lifting DURASLOT off any truck. We also do not recommend using a forklift for unloading DURASLOT off the truck. We also do not recommend using a forklift for DURASLOT that is not on a pallet or skid. DURASLOT should never be pushed off the side of the truck - it is not flexible like regular HDPE pipe!

<u>Approximate Truckload Quantities</u>		
<u>Dia.</u>	<u>2 1/2" Slot</u>	<u>6" Slot</u>
4"	10,000'	X
6"	4,000'	3,600'
8"	3,240'	2,960'
12"	1,280'	1,200'
15"	X	1,000'
18"	X	760'
24"	X	440'
30"	X	360'
36"	X	280'

(X - not a standard size - check with HCPS)

# HALL CONSTRUCTION PRODUCTS AND SERVICES

P. O. Box 1392, South Glens Falls, NY 12803

(518) 747-7047

## DURASLOT® Installation Practices

DURASLOT surface drains are made from a flexible conduit, which is designed to attain its structural strength utilizing ring compression derived from soil pressure. For this to occur, a minimum height of cover is required. Since this is not possible, the drain must be backfilled with concrete to allow it to accept vehicular traffic. This is true of any pipe with an inlet mounted on top to form this type of surface drain. The pipe cannot function in the manner for which it was designed when it is installed this close to the surface. The concrete-filled trench provides the actual structure for this type of design.

Following are some of the most often utilized installation details for DURASLOT surface drains.

- (A) Heavy Traffic - completely surrounded by concrete for critical loading applications. This would include frequent high-speed H-20 traffic, such as a highway. The dimensions 'S' and 'B' are generally 3" to 6" depending on the specific conditions for the project (design layout, traffic patterns, soil properties, etc.)

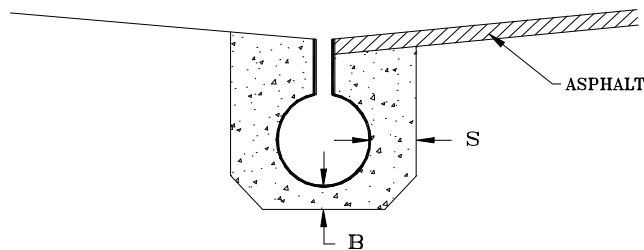

HEAVY TRAFFIC CONDITION

- (B) Moderate Traffic - surrounded by concrete to below the center of the pipe. This type of installation has been used when traffic loads are not as heavy (i.e., retail parking lots, against curbs, etc.). The soil below the pipe and concrete must be high quality and well compacted.

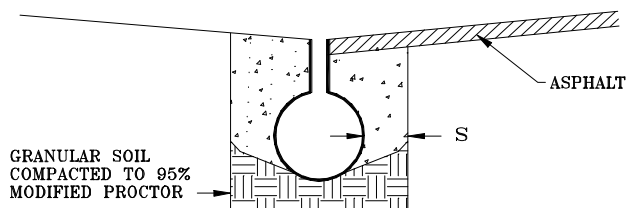

MODERATE TRAFFIC CONDITION

# HALL CONSTRUCTION PRODUCTS AND SERVICES

P. O. Box 1392, South Glens Falls, NY 12803

(518) 747-7047

## DURASLOT® Drains - Installation Notes - 1.0

DURASLOT must first be set and secured in place - some methods that have been used:

1. Hung from cross members on grade:

2. Set in a cradle made of rebar or wood:

3. Nested in the bottom of the trench (not for H-20 loading)

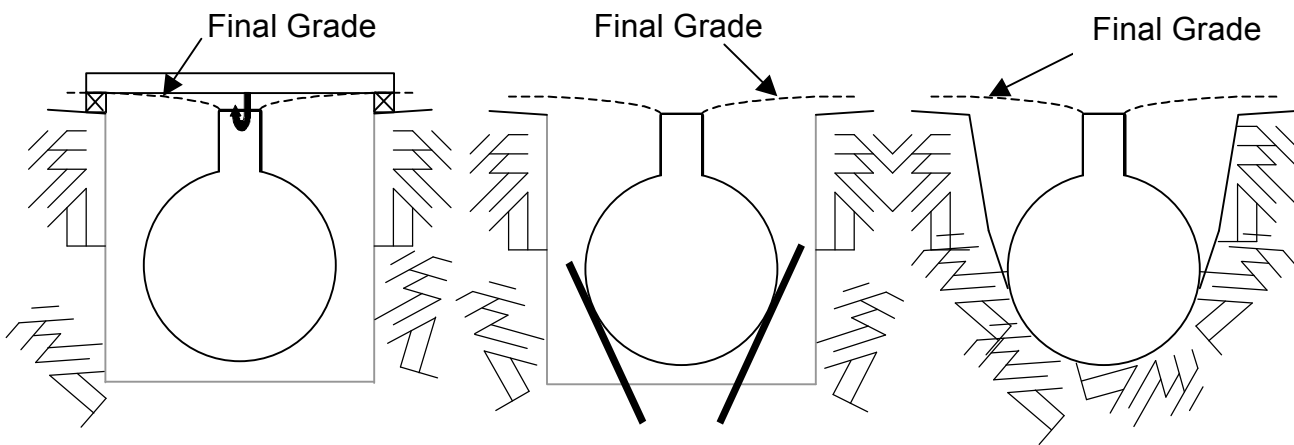

Before concrete is poured or asphalt is laid down, the slot opening should be covered to prevent it from being clogged. If you hang the DURASLOT, a good way to do this is to put 2" duct tape over the slot opening (1). If the pipe is sitting in a cradle or the trench bottom, a 2" x 4" can be set on the 2" edge on top of the grating (2).

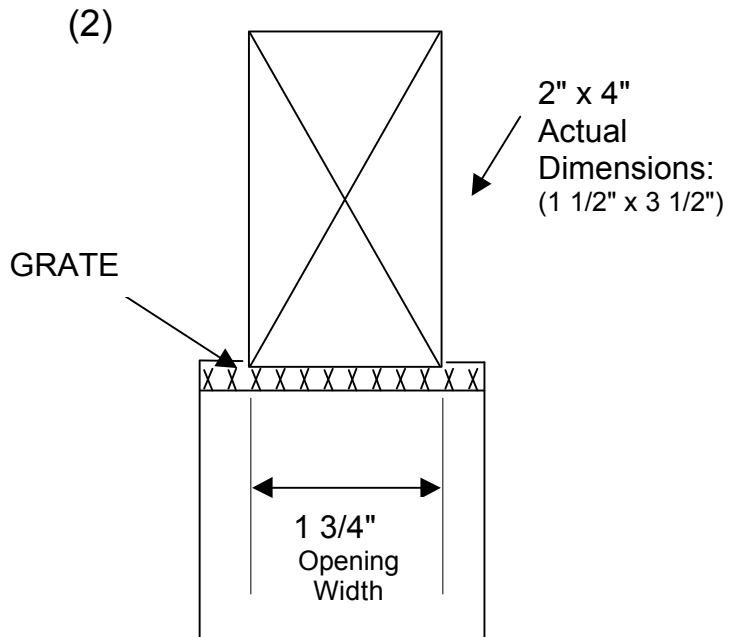
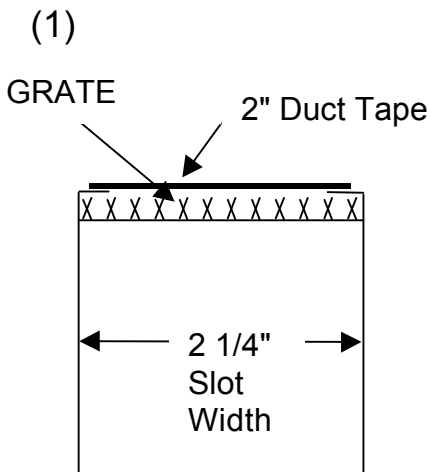

# HALL CONSTRUCTION PRODUCTS AND SERVICES

P. O. Box 1392, South Glens Falls, NY 12803

(518) 747-7047

## DURASLOT® Drains - Installation Notes - 2.0

When pouring concrete around DURASLOT, especially when the pipe is sitting in a cradle, pour down on the spot where the pipe meets the slot (X) [taking care to keep the slot upright]. This type of pour will provide some downward force (D) that will serve to keep the pipe from floating due to upward force (F) as the concrete fills the trench.

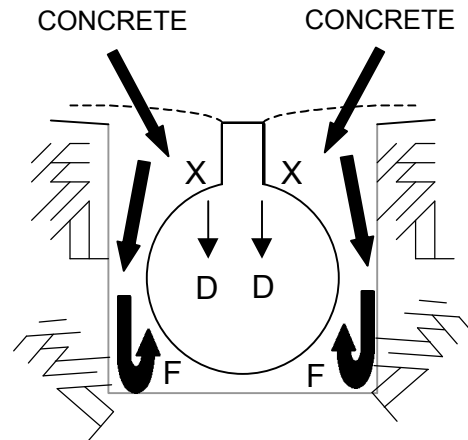

The top of the DURASLOT at the slot opening should always be set 1/8" to 1/4" below finished grade. This allows surface run-off to enter the inlet efficiently and protects the grate and flanges from snowplows and the like. A mason's tool can be used to knurl the edge after the tape or 2" x 4" has been removed.

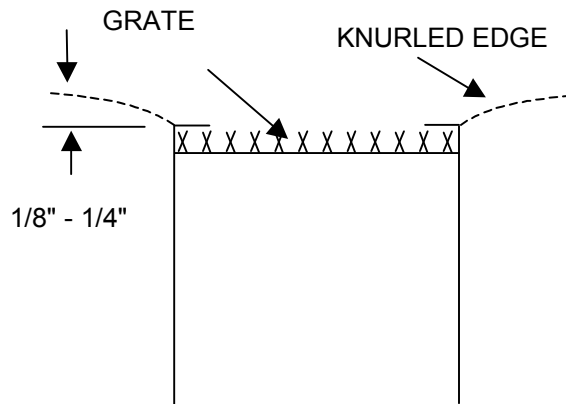

It is important that all fittings and hardware are used when DURASLOT is installed. The product is designed as a system: all grate connectors and anchors must be used to keep the grate in tension, and to tie the ends of the grate into the concrete or asphalt. At the end of each run an end cap or adapter should always be utilized (these include the anchor). Only DURASLOT Couplers should be used to join sections of DURASLOT. See the Assembly Details or call HCPS at (518) 747-7047 with any questions.