



Food Establishment Standard of Care

Table of contents

1. Food Service Establishment Guideline with Checklist.
2. Housekeeping and Maintenance General Practices.
3. Typical Food Establishment Contract.
4. Current Housekeeping and Maintenance Requirement per Contract.
5. List of On-Site Food Establishment.
6. Appendix.
 - Team Members.
 - Indirect Waste Solids Interceptor Detail.
 - Related Stanford University Facilities Design Guides.

Food Service Establishment Guideline with
Checklist

**STANFORD UNIVERSITY
FACILITIES DESIGN GUIDELINES**

FOOD SERVICE ESTABLISHMENT DESIGN GUIDE

PART 1-GENERAL

1.1 INTRODUCTION

- A. This design guide provides guidelines for the design of food service establishments (FSE). The guidelines are intended for use by project managers, design-build contractors, and design teams (architectural, mechanical, electrical and plumbing consultants). The design guide is aimed at developing FSEs that are easy to maintain, operate and provide a clean working environment.
- B. Stanford University encourages energy efficiency and water conservation when designing FSEs. This guide will list requirements and make recommendations for energy efficiency and water conservation.
- C. The design guide is organized by discipline with recommendations and requirements for each discipline.
- D. This design guide was written in July 2013 and is based on codes that were in force at the time. Design teams are responsible for insuring that the design of any FSE is in compliance with current code.
 - 1. Revision Record
 - a. Original Document: August 2013

1.2 REFERENCES AND STANDARDS

- A. The following references and standards shall be consulted and appropriate provisions incorporated into the design.
 - 1. Codes and standards:
 - a. City of Palo Alto Municipal Code
 - b. Santa Clara County Public Health Code
 - c. California Health and Safety Code
 - d. California Plumbing Code.
 - e. California Building Code.
 - f. California Fire Code.
 - g. California Mechanical Code
 - 2. Additional Standards:
 - a. NSF National Science Foundation
 - b. ANSI American National Standard Institute

- c. ASME American Society of Mechanical Engineers
 - d. ASTM American Standards for Testing and Materials
 - e. ASSE American Society of Sanitary Engineers
 - f. AWWA American Water Works Association
 - g. IAPMO International Association of Plumbing and Mechanical Officials
 - h. NBS National Bureau of Standards
 - i. NFPA National Fire Protection Association
 - j. PDI Plumbing and Drainage Institute
 - k. UL Underwriter's Laboratory
3. Stanford University Facilities Design Guide (FDG)
- a. Many sections of the FDG govern components of FSE design. This guide expects compliance with the FDG.
 - b. MEP Quick Guide
 - c. Stanford University Food Service Establishments Resources
 - 1) <http://lbre.stanford.edu/sem/kitchenprogram>

1.3 QUALITY ASSURANCE

- A. Manufacturer's Qualifications: Firms regularly engaged in the manufacture of plumbing and fountain systems products, of types, materials, and sizes required, whose products have been successfully installed on similar projects for a minimum of 5 years.
- B. Installer's Qualifications: Firm with at least 5 years of successful installation experience on similar projects.
- C. Manufacturer's Instructions: Manufacturer's instructions shall be followed where the manufacturers of the components used in the water feature have been provided.

1.4 WORK RESPONSIBILITIES

- A. Coordinate the work with other trades.
- B. Verify the location of all existing utilities prior to construction and protect from damage.
- C. Install pipe with necessary offsets and fittings to maintain required accessibility, and satisfy the University's Representative.
- D. Provide complete functioning systems and include all necessary components required for the water feature to operate safely and satisfactorily.
- E. Provide work indicated on the Drawings whether or not specifically mentioned in the Specifications.

1.5 SUBMITTALS

A. During Schematic Design:

1. Submit a preliminary FSE equipment layout and equipment schedule with equipment tags.
 - a. The drawing shall be sufficient for preliminary mechanical, plumbing and electrical team members to plan their work.
 - b. The drawing shall indicate how food, dishes and deliveries will flow through the FSE.
 - c. The drawing shall designate space for grease interceptors, food strainers, and janitorial storage.

B. During the final design phase provide a detailed design submittal. Include the following:

1. Complete plan drawings at a scale of 1/4 inch equals 1 foot of the FSE with all disciplines work indicated on the drawings. Small FSEs may submit combined services drawings incorporating multiple trades on one drawing. Medium and large FSEs shall have separate drawings for each trade.
2. Complete design calculations for:
 - a. Sanitary waste pipe sizing
 - b. Grease waste pipe sizing
 - c. Grease interceptor sizing
 - d. Water heater sizing
 - e. Gas pipe sizing
 - f. Potable cold and hot water pipe sizing
 - g. Kitchen cooking exhaust duct velocities
 - h. Fan and AHU static pressure calculations
 - i. Electrical load calculations for food service equipment
 - j. Panelboard ampacity and capacity calculations
 - k. Calculation for lighting levels demonstrating compliance with California Health and Safety Code Part 7; California Retail Food Code section 11 42 52

Calculations shall include a summary of fixtures, fixture units, and water flow rates for each service.

3. An estimate of the average number of meals served per day.
4. An estimate of average daily and yearly water consumption.
5. An estimate of average daily electrical power consumption.
6. An estimate of average daily natural gas consumption.
7. Energy model showing code and LEED compliance as applicable.

C. During Construction the contractor shall submit product data and catalog cut sheets for:

1. All specified components.
2. All equipment items.

3. All materials proposed for substitution.
 - a. Clearly indicate in submittal package those items that are proposed substitutions.
 - b. Submittals for items proposed for substitution shall specifically include performance characteristics, material, finish, and Certification of Performance with specified codes and standards.

- D. Detailed Drawings: Submit detailed drawings for review per Stanford Facilities Design Guide Section 01334.

- E. Record Drawings:
 1. Keep an accurate record set of Drawings per requirements of Stanford Facilities Design Guide Section 01770.
 2. Provide final as-built, reproducible drawings that include the following:
 - a. All valves clearly marked and identified.
 - b. Position of all concealed piping accurately dimensioned both vertically and horizontally.
 - c. Locations of all concealed pipe bends, dimensioned from 2 reference points.
 - d. All FSE equipment with labels and schedule with reference to manufacturer's maintenance and operations manual.

- F. Operation and Maintenance Manual: Prepare and deliver to the University's Representative prior to acceptance of the Work, in ring binders and on CD-ROM, operations and maintenance manuals containing the following information:
 1. Catalog and parts sheets on every material and equipment installed under this Contract.
 2. Index sheet stating Contractor's address and telephone number, and a list of equipment with the name, address, and telephone number of the local manufacturer's representatives.
 3. Complete operating and maintenance instructions for all equipment.
 4. Recommended inspection and maintenance schedule.
 5. Complete and dated warranties for all materials used.

1.6 PRODUCT DELIVERY, STORAGE AND HANDLING

- A. All pipe and appurtenances shall be loaded for delivery in such a manner as to avoid scratches or damage to the pipe or appurtenances.

- B. Delivery of pipe and other equipment to the site of the work shall not take place until immediately prior to installation.

- C. All pipe and other equipment and materials shall be handled with care to avoid scratches and damage. Piping shall be protected from damage during installation.

- D. Replacements: In the event of damage, immediately make all repairs and replacements necessary to the approval of the University's Representative.

PART 2 -DISCIPLINE GUIDELINES

2.1 GENERAL

- A. Use only new materials of brands, types, quality and performance indicated on the Drawings and specified herein, or approved equals.
- B. Where practicable, the products of a single manufacturer for each type of material or equipment shall be used throughout all work specified under this Section.
- C. Provide all special tools for proper operation and maintenance of the equipment under this Section and deliver to the University's Representative.

2.2 ARCHITECTURAL CONSIDERATIONS

- A. Included spaces and areas: FSEs shall include spaces for the following functions:
 - 1. Trash Enclosure: The trash area shall accommodate all required trash bins. The space shall have sufficient area for waste that is sorted into different bins: cardboard, glass and metal, compost, grease, and landfill. Additional requirements for trash enclosures are noted in a separate section below.
 - 2. Janitor's Closet: the janitor's closet shall be large enough to store cleaning supplies and shall have a floor mounted mop sink. Recommended minimum size for the janitor's closet is 6 ft wide, by 8 ft deep.
 - 3. Dish and Pot Wash: Dish and Pot wash areas shall be separated from food service preparation areas. The dish room shall be at a negative pressure from adjacent areas to reduce the migration of humid air.
 - 4. Floor mat wash area: An area shall be designated for washing floor mats. The area shall be provided with hot water hose bibb and a drain to grease waste. The area shall be located such that the cleaning process does not contaminate food or cooking areas.
 - 5. Vermin mitigation measures shall be provided as required by code

- B. Sight lines

The layout of the FSE cooking areas shall consider the flow of food and materials to cooking areas and from food storage areas. Large obstructions shall be avoided to allow visibility.

- C. Cleanliness of surfaces

- 1. Food contact surfaces shall be smooth, free of breaks, crevices and free of sharp corners.
- 2. Non-food contact surfaces that are exposed to splash, spillage or other water or food soiling shall be constructed of a corrosion-resistant, non-absorbent, smooth material that permits easy cleaning.
- 3. Surfaces that require frequent cleaning shall be constructed of a corrosion-resistant, non-absorbent, smooth material that permits easy cleaning.
- 4. The floor surfaces in all areas in which food is prepared, prepackaged, or stored, where any utensil is washed, where refuse or garbage is stored,

where janitorial facilities are located, and in all toilet and hand washing areas shall be smooth and of durable construction, water tight and non-absorbent material that is easily cleanable.

5. The walls and ceilings of all rooms within the food preparation, storage and cleaning areas shall be durable, smooth, non-absorbent and easily cleaned materials.
6. Floor mats and duckboards shall be designed to be easily removed and cleaned.

D. Carpets

1. No carpets shall be used in any area associated with the food handling, preparations, and storage.
2. Carpets shall not be used in any room or area subject to splash, spillage of water or food.
3. Carpets shall not be used in FSE offices or spaces frequented by FSE staff in the normal course of their work.
 - a. Carpets may be provided in dining areas with the agreement of the Stanford University representative.

2.3 MECHANICAL

A. Ventilation Cooking Hoods

1. Mechanical exhaust ventilation equipment shall be provided over all cooking equipment as required to effectively remove cooking odors, smoke, steam, grease, heat, and vapors. All mechanical exhaust ventilation equipment shall be installed and maintained in accordance with the California Mechanical Code.
2. Short circuit and air curtain type cooking hoods shall not be installed.
3. Make-up air (MUA) to kitchen exhaust hoods shall be provided through transfer air from adjacent spaces where possible.
4. Exhaust ventilation hood systems in food preparation and ware washing areas, including components such as hoods, fans, guards, and ducting, shall be designed to prevent grease or condensation from draining or dripping onto food, equipment, utensils, linens, and single-use articles.
5. Velocities shall be provided for each section of exhaust ventilation hood ductwork at the completion of the final design phase. These duct velocities shall demonstrate a minimum velocity of 1400FPM (at stated hood design exhaust CFM), and a maximum velocity of 2500FPM.
6. Evaluation of cooking hood demand control ventilation (Melink, Halton Marvel or equivalent) shall be provided to demonstrate that the most appropriate, cost appropriate (life cycle) design solution has been selected and integrated within the final design.
7. Architectural layout shall optimize use of transfer air from adjacent spaces, and provide low pressure transfer path. Make-up air (MUA) to kitchen exhaust hoods shall utilize the fresh air provision from transferring spaces to reduce local MUA kitchen supply.

8. Evaluation of suitability for pollution control units shall be provided as part of the design. Electrostatic or multi-stage filter units shall be provided in line with hood exhaust systems as is appropriate to each cooking type.
9. Filters, grease gutters or other grease extracting equipment shall be designed to be readily removable for cleaning and replacement if not designed to be cleaned in place. Exhaust hood and ducts shall be designed to provide sufficient number of clean-outs and easy access to clean-outs. Where filtration units are located in dedicated rooms, exhaust shall be provided to prevent the migration of odor during filter replacement.
10. Hood exhaust external duct external terminations shall be installed away from and downwind (prevailing) of building outside air intakes to prevent odors from circulating into buildings.

B. General Ventilation

1. General ventilation and cooling of kitchen spaces shall be provided with an all-air VAV or displacement system.
2. Position of ventilation ceiling diffusers within kitchen spaces shall be such that they do not interfere with hood performance. Air thrown from ceiling diffusers shall not be directed towards the hood. Air terminal velocities at the hood line shall not exceed 50fpm. Consideration shall be given to using displacement ventilation within kitchen areas.
3. Kitchen spaces shall be at an overall negative pressure to adjacent areas to prevent the migration of odors.
4. Local dining spaces shall utilize occupant demand control ventilation (DCV) while providing a control sequence that allows for appropriate use of transfer air as kitchen make-up. The DCV system shall not starve transfer air to the kitchen spaces.
5. Natural ventilation of any areas open to cooking and food preparation shall address ingress of vermin and health code compliance restrictions.

C. Exhaust

1. Trash enclosures, mat washing areas and dish washing areas shall have sufficient exhaust to prevent the migration of odors to other areas of the FSE.

D. Dish Washing Spaces

1. Dish washing spaces shall be provided with a sufficient air change rate and negative pressure to prevent high moisture levels and the migration of odors to other areas of the FSE.
2. Dishwasher hoods shall be interlocked with the HVAC system to allow for a balanced system.

E. Insulation

1. Walk in freezers, cold receiving spaces and similar shall be provided with appropriate insulation and adjustments to slab heights to provide an integrated solution.

2.4 PLUMBING

A. Hot Water

1. Commercial dishwasher utilized for ware washing is capable of providing heat to the surface of the utensils of a temperature of at least 160°F. Cafes need to provide means to boost the water temperature for dishwashers if necessary.
2. Hot water shall be supplied to cooking appliances and equipment shall be provided at a minimum temperature of at least 120°F measured from the faucet, unless otherwise specified in this part.
 - a. Hand washing sinks shall be provided with hot water not exceeding 110°F using a mixing valve integrated with each faucet.

B. Grease Waste

1. All FSEs shall incorporate grease interceptors for current and future use. Grease interceptors and grease piping shall comply with the requirements of this section and with Stanford FDG section 15405.
2. Grease waste piping:
 - a. Grease waste piping shall be cast iron.
 - b. Grease waste piping shall be sloped at 2% minimum for all sizes of pipe.
 - c. Grease waste piping shall include cleanouts at each change in direction and every 20 feet.
 - d. A main cleanout shall be provided after the last fixture and before the grease interceptor. This cleanout shall be a two-way cleanout.
 - e. Fixtures and equipment shall connect to the grease waste system with indirect drains unless a direct connection is required by code. If a direct connection is required by code then a floor sink shall be installed between the fixture and the next downstream connection.
 - f. Dishwashers shall not be connected to the grease waste system.
 - g. Condensate drains shall not connect to grease waste piping.
 - h. Ice maker drains shall not connect to grease waste piping.

C. Strainers

1. All sinks and equipment plumbed to waste piping shall include strainers to capture food scraps. Strainers shall be easily accessible and cleaned when full or every day as part of daily cleaning.

D. Drains

1. Indirect and direct wastes
 - a. Indirect drains are preferred for all fixtures and cooking equipment if permitted by code.
 - b. Hand sinks and restroom fixtures shall have standard direct connections and must not be plumbed to grease interceptors.
2. Drains should not include sediment buckets.

3. Floor drains located in cooking areas, under mats and in areas where food spillage may occur shall be connected to the grease waste system.
 4. Drains shall be labeled with "GW" or "SW" machined into the rim of the drain body to identify which system the drain is connected.
- E. Water supply.
1. Hot and cold water piping shall be insulated. Hot water shall comply with Title 24 requirements. Cold water shall have ½ inch insulation.
 2. Insulation shall be elastomeric or other closed cell type suitable for wet environments.
 3. Recycled water shall not be routed in or through any FSE. Plumbing fixtures for FSE staff use shall not use recycled water.
 4. Janitor's sinks shall have a backflow preventer on the water supply to the fixture and a vacuum breaker at the spout.
- F. Sewage Ejectors
1. FSEs located below the sewer main that utilize sewage ejectors shall include a bubble diffuser in the ejector pit to prevent solidification of solids in the sump.
 2. Sewage ejector sumps shall not be located in any area where food handling may occur.

2.5 ELECTRICAL AND LIGHTING

- A. The food service designer and the electrical engineer shall work together to verify that correct electrical connectors are specified for all equipment.
- B. The engineer shall coordinate with the food service designer to insure that the electrical distribution system provides the correct voltages for all food service equipment.
- C. The food service equipment shall be connected to panelboards dedicated to the FSE and shall utilize the correct diversity as permitted by NEC 220.56
- D. Provide 25% space ampacity and capacity on panelboards serving the FSE.
- E. Covered outlets shall be provided in all cooking areas and areas subject to hose spray including, but not limited to:
1. Mat washing areas
 2. Cart washing areas
 3. Trash enclosures
 4. Loading docks
 5. Food storage rooms and coolers
- F. In every room and area in which any food is prepared, manufactured, processed, or prepackaged, or in which equipment or utensils are cleaned, sufficient natural or artificial lighting shall be provided to produce lighting intensity per California Health and Safety Code Part 7; California Retail Food Code section 11 42 52

- G. The design team is encouraged to specify high efficiency LED lighting in walk-in coolers, refrigerators and freezers.
- H. Lighting designers shall specify lighting fixtures with a minimum Color Rendering Index (CRI) of 90 or higher in food preparation, serving, and dining areas.
- I. Luminaires in public spaces should have correlated color temperature of 3500K or warmer.

2.6 FIRE PROTECTION

A. General requirements

1. All FSEs shall have a fire suppression sprinkler system designed to comply with the requirements in the CBC and CFC.
2. The FSE shall be a separate zone for both sprinkler and fire alarm system and shall be shown as such on the fire alarm control panel.

B. Hood and grease exhaust ducts

1. Commercial cooking equipment that produces grease laden vapors shall be provided with a Type I Hood, in accordance with California Mechanical Code, and an automatic fire extinguishing system.

C. Coordinate the connections between FSE hood fire suppression systems with the fire alarm system.

2.7 SPECIAL REQUIREMENTS

A. Trash enclosures

1. Trash enclosures have special requirements requiring a coordinated approach with the design team, Stanford University and the contractor.
2. Trash enclosures should be located outside away from any outside air intakes.
3. The enclosure must have a roof
4. The enclosure must be large enough to hold all required trash bins including the various recycling bins.
5. Drains are not required to be installed in trash enclosures. If the enclosure has a drain it must be connected to grease waste.
6. Provide active ventilation
7. Design trash enclosures to minimize access by vermin.

B. Tallow bin

1. All FSEs shall have a receptacle, a tallow bin, for containing waste fats, oils and greases (FOG). The tallow bin shall be sized appropriately for the type of FSE and the generation rate of FOG.
2. Tallow bins shall be steel or double walled polypropylene and have a lightweight removable lid with a locking mechanism.

3. Tallow bins that are 55 gallons or more shall be located on a 4 inch tall housekeeping pad with a 4 inch curb around the bin to contain spills.
4. Tallow bins that are 55 gallons or more shall be secured to the housekeeping pad to comply with seismic restraint requirements.
5. Tallow bins shall be located for easy access by the grease collection vendor.

PART 3 -DESIGN CHECK LIST

Food Service Establishment Design Checklist

Phase Schematic Design

Item	Description	Does Project Design Comply with Guideline? (Yes/No/Non-Applicable) If ""No"", provide explanation"
General		
GSD1	Does the drawing set include a preliminary food service establishment equipment layout?	
GSD2	Does the layout include flow diagrams for food, delivers and dishes?	
GSD3	Are grease interceptors shown?	
GSD4	Are food strainers shown?	
GSD5	Is there storage for Janitors' cleaning materials?	
GSD6	Does the layout include a trash enclosure?	
GSD7	Are dish and pot wash areas separated from the food preparation areas?	
GSD8	Are the surfaces of walls and floors in the food preparation areas defined? Are the smooth and durable materials?	
GSD9	Is carpeting shown anywhere in the food preparation areas?	

Phase Design Development

Item	Description	Does Project Design Comply with Guideline? (Yes/No/Non-Applicable) If ""No"", provide explanation"
General		
GDD1	Does the set include 1/4 scale drawings of the food service establishment?	
GDD2	Does the trash enclosure have sufficient space for all waste and recycling bins?	
GDD3	Does the trash enclosure have a roof?	
GDD4	If drain is provided in the trash enclosure; is it plumbed to the grease waste/interceptor?	
GDD5	Is the trash enclosure ventilated?	
GDD6	Is there a tallow bin shown on the plans?	
GDD7	Are the materials of construction for the tallow bin specified?	
GDD8	Is there easy access to the tallow bin?	
Mechanical		
MDD1	Are exhaust hoods shown over cooking equipment?	
MDD2	Are the exhaust discharge vents away from building entrances and out side air intake louvers?	

Electrical		
EDD1	Are covered outlets specified?	
EDD2	Are lighting levels noted on the plans?	
EDD3	Were the calculations included for an estimate of average daily electrical power consumption?	
Plumbing		
PDD1	Were the calculations included for sanitary waste pipe sizing?	
PDD2	Were the calculations included for grease waste pipe sizing?	
PDD3	Were the calculations included for grease interceptor sizing	
PDD4	Were the calculations included for water heater sizing?	
PDD5	Were the calculations included for gas pipe sizing?	
PDD6	Were the calculations included for potable cold and hot water pipe sizing?	
PDD7	Does the project design document include for an estimate of the average number of meals served per day?	
PDD8	Were the calculations included for an estimate of average daily and yearly water consumption?	
PDD9	Were the calculations included for an estimate of average daily natural gas consumption?	
PDD10	Are clean out shown every 20 feet and at every change in direction?	
PDD11	Are connections to grease waste made with indirect connections?	
PDD12	Are the floor drains in cooking areas connected to grease waste piping?	
PDD13	Are cooler and ice machine drains connected to sanitary waste piping?	
PDD14	Is there a detail for the backflow preventer on the water supply lines to the janitor's sink?	
Fire Protection		
FPDD1	Is a hood fire suppression system specified?	
FPDD2	Are all areas of the food service establishment sprinklered?	

Housekeeping and Maintenance General Practices

General Practices for Housekeeping and Maintenance of Commercial Food Establishments

HOUSEKEEPING

Area	Task	Frequency	Suggested Roles & Responsibility
Flooring	Hard Flooring - General sweep and mop of kitchen and dining areas. Mop water must drain to grease interceptor. PAMC 16.09.075 (m)(2)(B)	At the end of each shift (Breakfast, Lunch & Dinner)	Operator
	Carpeted Flooring - Vacuum carpet	At the end of each shift (Breakfast, Lunch & Dinner)	Operator
	Flooring - Perform deep cleaning (power scrub/steam cleaning) of flooring to maintain sanitation and appearance. Zinc free floor wax/finish must be used. PAMC 16.09.200	Monthly	Operator
	Flooring (Exterior) - Power wash (pavers, concrete and arcade). Storm drains must be plugged all water must be collected. PAMC 16.09.075 (k)(3)(A) & (B)	Weekly	University
	Flooring - Spot clean all identified spills	Immediately	Operator
	Fatigue Mats - Rinse loose dirt	Daily	Operator
	Fatigue Mats - Pressure wash to deep clean	Weekly	Operator
	Walk-Off Mats - Vacuum and spot clean	Daily	Operator
	Walk-Off Mats - Replacement	Yearly	University
Windows	Windows, sills and screens - Spot clean interior and exterior	Daily	Operator
	Windows, sills and screens - Complete clean interior and exterior	Weekly	Operator
Ceiling	Ceiling - Clean and wipe down	Weekly	Operator
Wall	Walls - Light dusting	Daily	Operator
	Walls (interior) - Clean scuff and markings off	Daily	Operator
Tables	Tables (Interior and Exterior) - Clear and wipe	At the end of each shift (Breakfast, Lunch & Dinner)	Operator
	Tables (Exterior) - Power wash	Monthly	University
	Tables and Chairs - Reposition as necessary.	At the end of each shift (Breakfast, Lunch & Dinner)	Operator
	Tables and Chairs - Report all missing or damaged	End of Day	Operator
Umbrellas	Patio umbrellas - cleaned and maintained	Monthly	University
Benches	Benches - Cleaned, sealed and refinished	Yearly	University
Waste, Recyclables, Biodegradable (Compost)	Waste, Recyclable and Biodegradable (Compost) Containers (Local Bins) - Clean and empty	At the end of each shift (Breakfast, Lunch & Dinner)	Operator
	Waste, Recyclable and Biodegradable (Compost) - Place signage to identify all appropriate containers	At the end of each shift (Breakfast, Lunch & Dinner)	Operator
	Waste, Recyclables and Biodegradable (Compost) - Place all trash in the designated outdoor dumpster	At the end of each shift (Breakfast, Lunch & Dinner)	Operator
	Waste, Recyclables and Biodegradable (Compost) (entrance locations only) - Place all trash in the designated outdoor dumpster	At the end business day	University - DTZ
	Waste, Recyclables and Biodegradable (Compost) (General Main Dumpster) - Pick up service to empty	Daily	University - PSSI
	All waste containers must be clean and free of food waste/grease buildup on the exterior. Staff should close the lids to all compost bins after each day. Tallow drums should be sealed after each use. - PAMC 16.09.075 (k)(3)(B)	Daily	Operator
	Staff must keep a spill log with date and time - PAMC 16.09.075 (p)(2)(B)	As Needed	Operator
	Tallow drums >55 gallons require secondary containment. - EPA SPCC 112.12		Operator
Panel Surfaces	Stainless Steel Panels & Equipment - Spot clean	Daily	Operator

Maintenance

Topics	Task	Frequency	Suggested Roles & Responsibility
Architectural	Windows - Inspect, verify operation and repair as necessary	Daily	Operator/University
	Doors - Inspect, verify operation and repair as necessary	Daily	Operator/University
Mechanical	Kitchen Exhaust Duct - Cleaned of oil/grease. PAMC - 16.09.075 (k)(2)(C)	Monthly	University
	Filters - Replace HVAC air filters	Quarterly	University
Plumbing	Floor Drains - Preventive maintenance work order shall be issued to university's Plumbing Shop to clean drains and ensure priming	Bi-Weekly	Operator
	Sewage Line - Preventive maintenance work order shall be issued to university's Plumbing Shop to maintain system	Quarterly (Recommend Semi-Annual, may need to increase frequency as needed)	Operator
	Grease Trap - Preventive maintenance work order shall be issued to university's Plumbing Shop to maintain system. Grease traps/interceptors must be measured for compliance with the 25% rule. PAMC - 16.09.075 (f) & (n)(2)(A)	Monthly	University
	Sewage Ejector- Preventive maintenance work order shall be issued to university's Plumbing Shop to maintain system	Quarterly	University
Electrical	Lighting - Clean, verify operation and Relamp/reballast as necessary	Daily	University
	Exit Signs - Test, verify operation and repair as necessary	Monthly	University
Fire Suppression	Fire Sprinkler - Inspect, test system and repair as necessary	Yearly	University
Pest Control	Independent Pest Control - Contract to treat and inspect pests	Yearly	Operator
Equipment	University Supplied Equipment - Provide necessary maintenance per manufacture's recommendation	Per Manufacturer's Recommendation	University
	Operator furnished Equipment - Provide necessary maintenance per manufacture's recommendation	Per Manufacturer's Recommendation	Operator
	General Equipment - Cleaning outside of designated wash stations is strictly prohibited. Refer to Stanford Facility Design Guideline Section 15210 - Fat's Oil and Grease (FOG) Waste Management System. Also see PAMC 16.09.075 (m)(2)(B)	Daily	Operator

Disclaimer

1-Suggested roles and responsibilities shall be used as guideline.

2-Funding source for the different tasks varies and depends on contract set-up.

Abbreviations

PAMC

Palo Alto Municipal Code

EPA

Environmental Protection Agency

Typical Food Establishment Contract

STANFORD UNIVERSITY

SERVICES AGREEMENT

FOR

THE MANAGEMENT AND OPERATION OF _____ CAFE

THIS AGREEMENT is made and entered into effective ____, 2011, by and between The Board of Trustees of the Leland Stanford Junior University, a body having corporate powers under the laws of the State of California hereinafter referred to as "University" and _____, hereinafter referred to as "Operator," whose principal place of business is _____.

WITNESSETH

RECITALS:

- A. The University owns the building located at _____ ("The Building") on the Stanford University Campus. The Building contains, among other things, a space which shall hereinafter be named The _____ Café. The _____ Café includes < description of space>, and the fixtures identified in Exhibit B. All of these spaces are hereinafter referred to as The _____ Café and the precise boundaries of The _____ Café areas are set out in a Floor Map Diagram attached to this Agreement as Exhibit "D."
- B. Operator and University wish to make available to the faculty, students, staff and guests of the University an innovative and attractive food service and catering operation and ensure the ambiance and attractiveness of quality dining within a business environment.
- C. Operator and University desire to enter into this Agreement whereby the Operator will manage and operate The _____ Café.
- D. University shall designate a Contact person to oversee and support The _____ Café operations. The Contact person is named in Article 10 below.

NOW THEREFORE, in consideration of the revenue prescribed hereunder and of the agreements, covenants, and conditions contained herein and other good and valuable consideration, the parties hereby agree as follows:

ARTICLE 1

OPERATING RIGHT AND DUTY

Subject to the covenants and conditions herein contained, the University hereby grants to Operator the exclusive right to operate “The _____ Café,” for the sole purpose of providing food and beverage services for students, faculty, staff, and guests of the University. Operator shall make no other use of The _____ Café without the prior written approval of the Contact, identified in Article 10 below. Operator covenants to operate The _____ Café at all times during the term hereof, pursuant to the terms hereof.

ARTICLE 2

OPERATOR SERVICES

2.1 Scope of Services

Operator shall be available to fully operate The _____ Café and perform the services described in University’s Request For Proposal (“RFP”) dated _____, 2011, to which Operator responded in its Proposal dated _____, 2011, including Operator’s Responses to University’s questions/requests-for-clarifications during the RFP process. All such documents are incorporated herein by reference only. Operator’s services shall include, but not be limited to, the following:

- a. Provide food services that are consistent financially and operationally with the RFP and Operator’s Response Proposal.
- b. Purchase and distribute all food products and related supplies and materials necessary to operate The _____ Café”.
- c. Maintain daily sales records for The _____ Café and transmit such information to the Contact, on a monthly basis, or upon request by the Contact.
- d. Submit revenue statements as follows:
 - A statement of weekly sales.
 - A monthly total of sales
 - The amount due to University for the month.
 -

The monthly revenue statement shall be submitted to University by the 10th of the following month.

- e. Meet with the Contact or his/her designee, on request within reason, and at least once every six (6) months, to review Operator’s financial and operational performance. Operator’s on-site manager shall attend all such meetings.
- f. Cooperate in both quality assurance audits and financial audits of its management and operation of The _____ Café. The University will have the right to conduct quarterly quality assurance audits and annual financial audits. Quality assurance audits will be conducted without prior notice to Operator. The University will provide copies

of audit findings to Operator after review by appropriate employees or agents of University. The Operator's senior management must promptly address in writing any operational or accounting procedure adjustment required by the audits.

2.2 Personnel

- a. All services hereunder shall be performed by personnel experienced and highly skilled in their profession to the extent necessary for a particular position and in accordance with the highest applicable standards of professionalism for comparable or similar services. University shall not supervise nor control the detail of Operator's services, but rather shall be interested only in the results of Operator's services.
- b. Operator shall maintain an adequate staff of trained employees to provide services indicated above. Operator shall have at least one person, in a management capacity, on site during The _____ Café operating hours.
- c. Operator agrees to manage and supervise all persons utilized by it so as to ensure that they do not conduct themselves in a manner that will endanger any patron, and that they treat all patrons politely and considerately. Additionally, Operator agrees to ensure that staff adheres to University-wide policies (smoking, sexual harassment, etc.). These may be obtained on Stanford University's web site at < <http://harass.stanford.edu/> > and < <http://www.stanford.edu/dept/vpsa/judicialaffairs/guiding/other.smokefree.htm> >, or you may request hardcopies of such policies from the Contact.
- d. University reserves the right to consult with Operator regarding all management personnel assigned to this account. All employees must be U.S. citizens or otherwise lawfully able to work under U.S. law.

2.3 Interaction with the University

Operator at all times, in the performance of its duties hereunder, shall respond to the Contact and shall interact with such other persons or departments, as the Contact shall direct.

ARTICLE 3

PERIOD OF PERFORMANCE

3.1 Term

- a. The term of this Agreement shall be for ____ () years, starting on the Grand Opening date of The _____ Café, and shall be subject to early termination as provided in Article 19.
- b. At the sole option and discretion of the University, and based on satisfactory performance by the Operator and mutual agreement of the parties, this Agreement provides for ____ () -year extensions, with each extension being subject to early termination as provided in Article 19.

3.2 Operating Calendar and Schedule

Operator shall maintain the hours of operation as set forth in Exhibit "A," the Operation Schedule, to this agreement. Any alterations to the business hours must be approved by the Contact, and must be recorded in an updated "Operation Schedule" that will be made a part of this Agreement as Exhibit "A," via a bilateral Amendment.

ARTICLE 4

REVENUE SHARING TERMS

- 4.1 "Gross Revenues" as used herein, mean all revenues of whatsoever kind received and collected by Operator from or in connection with the premises, including catering sales, if any, but excluding sales taxes and gratuities, and without any other deductions or offset.
- 4.2 Gross Revenues from The _____ Café sales must support Operator's operating and overhead expenses with no subsidy from the University. (Optional: Except that the University will pay for the construction or ordering and installation of fixtures used within the Shop). Operator must also pay back to University, as commission, the Percentages of Gross Revenues specified hereunder.
- 4.3 Operator agrees to pay University, throughout the term of this Agreement, and pursuant to Section 4.4 below, the following commission payments based on Operator's Gross Revenues earned, as follows: ___% of gross sales.
- 4.4 Operator shall make commission payments to University on the tenth day of each month, based on the previous month's gross revenues. Payments not made by 5pm on the 10th day of the month shall be considered late and will be subject to a late charge equal to \$100.00 per day for each day beyond the 10th of the month. If the 10th day of the month falls on a non-working day, payment will become due on the next working day without incurring a late charge. Commission payment checks shall be made out to "Stanford University" and mailed to the address provided in Exhibit "G" of the Agreement.
- 4.5 Operator shall bear at its own expense any and all taxes imposed by local, state, or federal agencies on Operator's income, sales, employment and any other aspects of Operator's business, including personal property taxes on property owned by Operator. Operator shall collect sales tax on all services charged to the University unless University provides Operator with an exempt organization certificate covering the sale.
- 4.6 Property Taxes: Operator agrees to pay The _____ Café property taxes that are due semi-annually. Property tax checks shall be made out to "Stanford University" and mailed to the address provided in Exhibit "F" of the Agreement.
- 4.7 Operator may be asked to purchase computerized registers with remote polling capability for use in "The _____ Café." All registers should be approved by the Contact before purchase and installation.

ARTICLE 5

GENERAL OPERATING REQUIREMENTS

- 5.1 The intent of this Agreement is to provide the University community with quality food and service.
- 5.2 Any menu items subject to spoilage and/or contamination that are prepared off-site shall be prepared and transported to The _____ Café in accordance with federal, state, and local codes and regulations.
- 5.3 Operator shall make every reasonable effort to respond to the needs expressed by University.
- 5.4 Operator shall post, in clear view, current item pricing.
- 5.5 The Operator shall accept cash, debit cards and credit cards as methods of payment for customer purchases.

When processing payments, Operator must comply with Payment Card Industry regulations (Section 5.10.e). In order to distinguish the Operator's business from the University's, the Operator must establish a network separate from the University's for the purposes of processing payments.

Operator shall acquire its own non-Stanford network access in The _____ Café, and shall ensure that all University payment method compliance policies and practices and all applicable laws and regulations are followed, as described in this Agreement. Operator understands, acknowledges, and agrees that it will not use Stanford's network, internet domain and/or computer resources for the purposes of processing payments.

- 5.6 Operator shall respond to any requests from the University, whether written or verbal, concerning any price increases, and shall be prepared to demonstrate that increases are necessary to maintain Operator's profit margin and are not caused by deficiencies in Operator's business practices.
- 5.7 Operator may provide direct advertising including, but not limited to, fliers and promotional coupons. Operator shall obtain prior approval of all advertising materials from the Contact.
- 5.8 From time to time University may wish to make general offers/discounts available to students, faculty, and staff that will increase sales and/or goodwill. Operator agrees to work with University to successfully implement these special offers. University agrees to provide Operator with at least four (4) weeks advance written notice of these events and Operator agrees to provide adequate advertising of this special offer at least one (1) week in advance of event.
- 5.9 Operator shall maintain reasonably priced items, with selection input from the students, faculty and staff.
- 5.10 Operator's Administrative Responsibilities

The Operator shall have the following responsibilities:

- a. Notify the Contact immediately of any unsafe or unhealthy conditions and take appropriate action to remedy the condition(s).
- b. Obtain all necessary permits and licenses and pay all fees associated with the operation. Copies of all licenses and permits will be sent to the Contact within five (5) business days following their receipt by the Operator.
- c. Remit all license fees payable as required by approved licensing contracts.
- d. Be responsible for maintaining first aid equipment and supplies in all production and service areas.
- e. Handle credit card transactions in compliance with (i) the Payment Card Industry's (PCI) requirements, and any other legal requirements for matters including, but not limited to, safeguarding cardholder account numbers and other sensitive data, (ii) California state law related to handling of credit card transactions, and (3) any applicable University policies, procedures or practices. Certificates evidencing that The _____ Café complies with PCI requirements must be remitted to the University's Treasurer's Office each year. Applicable renewals of such certificates must be submitted to the University in a timely manner.
- f. Develop procedures for handling other payment transactions in compliance with (i) any legal requirements for matters including, but not limited to, safeguarding purchaser/customer private or other sensitive data, (ii) California state law related to handling of payment transactions, and (3) any applicable University policies, procedures or practices.

ARTICLE 6
UTILITIES, FACILITIES, AND EQUIPMENT

6.1 Utilities

- a. The University will supply heat/air and electrical current necessary for the operation of "CoupaExpress."
- b. The Operator will also pay the monthly phone/fax/computer access charges used in "The _____ Café." Operator's checks for such access charges shall be payable directly to the company providing phone/fax/computer access after December 31, 2011.
- c. If the Operator wishes to extend the services in ways that require additional electrical capacity, alterations will be made at the Operator's expense and not prior to having obtained written authorization from the Contact.
- d. The University does not guarantee an uninterrupted supply of electricity heat or air conditioning or other utilities. However, it shall use its reasonable efforts to restore service promptly following an interruption.
- e. Operator shall use reasonable efforts to minimize utility consumption and conserve energy, and shall comply with established energy conservation practices, regulations and policies.

6.2 Sanitation and Safety

- a. Operator shall operate and maintain The _____ Café in a clean, neat and safe condition and warrant that the operation shall comply fully with all relevant federal, state and local laws, codes and regulations, including the acquiring and maintaining of all necessary permits and licenses, and other requirements applicable to University.
- b. To ensure sanitation, health, cleanliness and to maximize customer appeal, Operator shall perform all cleaning and sanitation services necessary to maintain all areas of The _____ Café to the highest standards of sanitation including pest extermination. All tables (interior and exterior) shall be cleared and wiped as needed, and tables and chairs re-positioned as necessary. Operator shall report missing or damaged tables and chairs to the Contact.
- c. University shall provide waste containers in the dining areas in sufficient quantity to maintain sanitary standards for trash disposal. Waste containers inside and outside on the patios shall be kept in a clean and sanitary condition and emptied as often as necessary by Operator. All trash shall be placed in the designated outdoor dumpster by Operator's staff at end of each business day. All recyclable and biodegradable materials will be placed in appropriate containers at the end of each business day.
- d. Operator shall fully cooperate with all inspectors of state, local and University health departments and safety offices, and such persons shall have access to The _____ Café spaces and all food service, production and storage areas on inspections, which they may conduct. A copy of any health inspection report shall be furnished to the Contact within 24 hours of the inspection.
- e. Operator hereby agrees to begin implementation, within thirty (30) days of receipt of notice requiring same (or earlier if required by notice), corrective operating measures required or recommended as a result of such health inspections
- f. Nothing contained herein shall obligate or be deemed to obligate University to conduct any inspection of The _____ Café or exercise a particular standard of care in making an inspection. University shall not be liable for failure to make inspections or for failure to observe defects or unsafe conditions or for failure to notify Operator of same or to rectify any defects or conditions.
- g. Operator shall develop and implement a prudent program of accident prevention and safety education. Operator shall provide proper and sufficient instructions and training on the use of equipment and techniques of handling food and beverages to aid in the goal of having an accident-free and safe environment. First aid supplies (provided by Operator), and fire extinguishers and fire alarms (provided by the University) will be available for use as needed. Operator will train employees on where to find them and how to use them. All injuries and accidents are to be reported to the Contact promptly.
- h. Operator shall comply with University's Requirements set forth in the attached documents:
 - Special Conditions for Water Discharge Management and Environmental Pollution Prevention document

- Environmental Health & Safety document

6.3 Equipment, Furniture, and Fixtures

- a. All furniture and fixtures owned by University, as listed in Exhibit "B" of this Agreement, will be available for Operator's use.
- b. Operator agrees to take reasonable care and provide normal necessary maintenance and repairs of the University-owned equipment and cabinetry in "The _____ Café," listed in Exhibit "B". Operator will be held financially liable for the damage to University-provided fixtures and cabinetry as a result of Operator negligence. Operator shall return fixtures and cabinetry to the University in good condition satisfactory to the University allowing solely for ordinary wear and tear as is normally and customarily encountered in the industry and for obsolescence.
- c. Operator will be responsible for the purchasing, installation, and maintenance of any necessary appliances above what is provided by the University. All of such Operator-owned assets shall be listed in Exhibit "C" of the Agreement and shall be subject to paragraph (f) below. Contact must approve such appliances in advance of purchase/installation. Any approved appliances must be operated by The _____ Café personnel.
- d. Operator shall provide all of the computer systems and cash registers necessary to operate all aspects of "The _____ Café."
- e. Except for University-owned equipment and fixtures installed in "The _____ Café," Operator shall provide and be responsible for all equipment and any additional fixtures necessary to maintain operation. The costs for all such major new equipment and/or additional fixtures are to be recovered by Operator solely out of its regular revenues received under this Agreement, and must be depreciated over a seven (7) year period, and in accordance with the schedule detailed in Exhibit "E." This depreciation schedule is for the sole purpose of determining the purchase price of any specific piece of equipment or fixture, which the University might be interested in purchasing from Operator at the end of the Agreement term(s). In such event, the University will have the option, but not the obligation, to buy back such equipment and/or additional fixture(s) at the un-depreciated value, in accordance with Exhibit "E" and provided Operator gave copies of all invoices for such equipment and fixtures, at the time that the expense was incurred, to the Facilities Contact.
- f. Operator hereby agrees that, at the end of the depreciation schedule in Exhibit "E," the respective equipment and fixtures will become the property of the University, provided the University wishes to retain such equipment and/or fixtures.
- g. Operator shall take such measures as may reasonably be required for protection against loss by pilferage or destruction of any assets in "The _____ Café."
- h. Operator shall supply all smallware equipment required for the successful operation of The _____ Café. Smallware equipment consists of dishware, glassware, flatware, utensils, coffee machines, grinders, soda dispensers and similar loose items necessary for

normal operating requirements. All “To Go” containers, cups, and wrappings will be biodegradable whenever possible, or at a minimum recyclable.

- i. Operator shall purchase all paper, cleaning materials, and other supplies required for operation of “The _____ Café.”

6.4 The Facility

- a. The _____ Café is located _____, Stanford, California and occupies a total of _____ square feet of indoor space. In addition, <describe additional space, if any> (____ square feet). Total square footage is: _____.
- b. The Building shall be locked after hours and shall be accessible with the use of I.D. Cards. The Operator will have access to The Building as needed and will be responsible for securing The _____ Café facility at the end of each business day.
- c. The University shall have the full right of access to The _____ Café and all areas covered by the Agreement, at any and all times. In no event shall Operator license or in any manner permit any person or entity to use or occupy any such space except as specifically provided in this Agreement and no assignable or transferable property interest is created hereby. The _____ Café locks may only be changed with the prior written authorization of the Contact who will, if authorized, coordinate the change with the University lock shop.
- d. Operator shall not have the right to make temporary or permanent alterations, additions, or renovations to The _____ Café without the Contact’s prior written consent, which consent shall not be unreasonably withheld. The Operator may not alter the appearance of the area in any way without his prior written permission.
- e. Operator shall order and pay for The _____ Café signage. Designs shall be pre-approved by the Contact. Location of signage must be within the 133 square foot space and may not be outside or above the designated area. Specific location of signage must be pre-approved by the Contact prior to installation.
- f. Operator agrees to arrange for and pay for all electrical or other repairs caused by activities of the Operation.
- g. During the course of this Agreement, the University may make renovations to The _____ Café. The University shall provide Operator with prior notice of such renovations and shall work with the Operator to minimize disruptions.

ARTICLE 7

CODES AND REGULATIONS

All services performed under this Agreement shall conform to all applicable Local, County, State and Federal codes and regulations. Unless otherwise provided, the codes and regulations referred to above shall be the latest edition or revision in effect as of the effective date of this Agreement. Nothing in this Agreement shall be construed as requiring or permitting services that are contrary to the above-referenced codes and regulations.

ARTICLE 8

INSURANCE REQUIREMENTS

Operator shall not commence services under this Agreement until it has obtained all of the insurance required under this Agreement as described below, and such insurance has been approved by University.

Insurance required under this Agreement shall be:

- 8.1 Commercial General Liability (bodily injury, property damage, personal injury) with a single limit of not less than \$2,000,000, and Vehicle Liability insurance (covering vehicles used by operator and employees), with a single limit of not less than \$1,000,000 for a single occurrence.

Commercial General Liability and Vehicle Liability insurance shall include the following provisions:

- 8.1.1 **Additional Insureds:** Stanford University, its Board of Trustees, officers, employees, and agents, shall be included as additional insureds.
- 8.1.2 **Primary Coverage:** The Contractor's insurance shall be primary coverage, Stanford University and/or Stanford Hospital and Clinics insurance or self-insurance shall be excess and noncontributory.
- 8.1.3 **Cancellation Notice:** Thirty (30) days prior written notice of cancellation or material change in the insurance must be given to the University.
- 8.1.4 **Waiver of Subrogation:** Contractor and Contractor's insurance companies waive their rights to subrogation against the above named insureds.
- 8.2 Worker's Compensation insurance and employer's liability insurance covering all persons whom the Contractor may employ in carrying out the services hereunder. Worker's compensation insurance will be in accordance with the Worker's Compensation Law of the State of California.
- 8.3 Personal Property Insurance with a limit sufficient to cover all of Operator's property and contents (including food and beverage).
- 8.4 The insurance arranged by Operator shall include contractual liability insurance insuring the indemnity clause of this Agreement set forth in Article 10, below.

Prior to the commencement of services described herein, Operator shall furnish the University with Certificates of Insurance (or evidence of self-insurance, if appropriate, and acceptable to the University) for all insurance required in the preceding paragraphs.

ARTICLE 9

INDEMNIFICATION

Operator shall indemnify, defend and hold the University, its trustees, officers, employees, agents, and students harmless from any and all claims arising in whole or in part out of any injury or death of any person, or damage to any property, including Operator’s partners, employees, subcontractors, and agents, resulting in whole or in part from the use or operation of the premises by Operator or negligence or willful misconduct of Operator, its partners, employees, subcontractors, or agents.

ARTICLE 10

COMMUNICATIONS

All written notices and/or correspondence pertaining to this Agreement shall be addressed to the Contact with a copy to the Contract Specialist, as they are identified below:

_____ is the Contact person, pursuant to this Agreement.

Contact

Stanford, CA 9430-_____

Email: _____

Phone: (650) _____

Correspondence to Operator shall be addressed to:

Contract Specialist:

Attn: _____

_____, CA 94301

Phone: _____

Fax: _____

Email: _____

Procurement Services
3145 Porter Drive
Palo Alto, CA 94304-8440
Phone: (650) 723-_____
Fax: (650) 723-2429
Email: _____

ARTICLE 11

CONFIDENTIAL INFORMATION

11.1 In the course of providing services hereunder, the parties may be exposed to trade secrets or other confidential or proprietary information and materials of the other party all of which shall be contain a legend identifying the information as confidential (“Confidential Information”). The parties agree to hold in confidence and not to disclose any Confidential Information for two (2) years after the Confidential Information is made available to the receiving party, except that the parties may use or disclose Confidential Information: (a) to its employees and affiliates or others to the extent necessary to render any service hereunder, provided that the other party is first

notified of the information that will be provided to any party outside of this Agreement and provided further that such information is disclosed only after such party is required to maintain it in confidence as required hereunder; (b) to the extent expressly authorized by either party; (c) to the extent that at the time of disclosure, such Confidential Information is in the public domain, or after disclosure, enters the public domain other than by breach of the terms of this Agreement; (d) that is in the possession of either party at the time of disclosure and is not acquired directly or indirectly from the other party; (e) that is subsequently received on a non-confidential basis from a third party having a right to provide such information; or (f) as required by order or other legal process during the course of a judicial or regulatory proceeding or as required by a government authority. The parties agree not to photocopy or otherwise duplicate any Confidential Information without the express written consent of the other party. Each party's Confidential Information shall remain the exclusive property of the party and shall be returned to the other party upon termination or expiration of this Agreement. In the event of any breach of this provision, the parties shall be entitled to seek equitable relief, in addition to all other remedies otherwise available to it at law. This provision shall survive the termination or expiration of this Agreement.

- 11.2 Operator agrees to handle data and other information generated from financial transactions involving the Stanford community ("Data") according to Payment Card Industry Security Standards (PCI DSS) Compliance standards, https://www.pcisecuritystandards.org/security_standards/index.php?id=pci_dss_v1-2.pdf, if applicable, or using secure standard financial industry practices, if PCI DSS standards are not applicable. The University reserves the right at any time to request either proof of PCI DSS compliance or a certification (from a recognized third-party security auditing firm) verifying Operator uses secure standard financial industry practices in its financial transactions, and maintains ongoing compliance under PCI DSS standards and/or secure financial industry practices as they change over time. Exhibit H provides a list of payment applications Operator will use to conduct financial transactions under this Agreement; Operator will provide 30 days notice prior to adding or removing any payment applications. Operator will comply with all laws relating to the collection, use, storage, protection and breach of Data, including but not limited to the California Money Transmission Act. Operator warrants that it will not use any University system in connection with financial transactions under this Agreement, and without limiting the foregoing, further warrants that it will not store or transmit Data using the University's system. Operator will give immediate notice to the University of any actual or suspected unauthorized disclosure of, access to or other breach of the Data. The parties agree that Operator is entirely responsible for Data generated under this Agreement and Operator will indemnify the University for its violation of this paragraph. This paragraph and its indemnity will survive the termination of the Agreement.

ARTICLE 12**EXAMINATION OF RECORDS**

- 12.1 University shall have access to and the right to examine any directly pertinent books, documents, papers and records of Operator involving transactions related to this Agreement until four (4) years after expiration of the Agreement. Operator agrees to keep and maintain such records for such period of time.
- 12.2 Operator shall make available, upon written request from the Secretary of the United States Department of Health and Human Services or from the United States Comptroller General, or any of their duly authorized representatives, this Agreement and such books, documents and records of Operator as are necessary to certify the nature and extent of the reasonable cost of services to the University. This paragraph shall be of force and effect only to the extent required by P.L. 96-499.

12.3 Books and Records

Operator shall keep and maintain at The _____ Café or at such other place as University may approve in writing, complete and accurate books of accounts and records of all operations performed under this Agreement. Operator agrees to record all sales, at the time each sale is made, whether for cash or credit, in a cash register or registers containing block-cumulative tapes with cumulating capacity satisfactory to University. Operator shall be able to categorize all revenue transactions into one of three categories: retail food, retail drink or catering. Operator shall keep for at least four (4) years following the termination of this Agreement all pertinent original sales books, and records, which records shall include: (a) daily dated register tapes identified by food service unit; (b) serially numbered sales slips; (c) payroll records; (d) all purchasing invoices; (e) settlement report sheets of transactions with subcontractors, concessionaires and affiliates; (f) duplicate bank deposit slips and bank statements; (g) such other records as would normally be required to be kept and examined by an independent accountant in accordance with generally accepted auditing practices in performing an audit of Operator net sales; and (i) all income, sales and occupation tax returns.

12.4 Audits

The acceptance by University of payments, operating statements and reports shall be without prejudice of University's right to an examination of Operator's books and records of its net sales, and inventories in order to verify the amount of Operator's net sales. At any reasonable time prior to four (4) years after the termination of this Agreement, University may cause an audit to be made of Operator's business affairs and records relating to this Agreement for the period covered by this Agreement. If the books of accounts and records of Operator are kept at some location other than "The _____ Café," Operator agrees, at University's expense, to transport such books and records to "The _____ Café," or, at University's option, to some other location selected by University within Santa Clara County, within ten (10) days of such written notice of an audit. Any such audit performed by an independent auditor, selected by University, shall be binding upon the parties. Any such audit shall be paid for by University unless such audit shall determine that there is a deficiency in the payment of funds due the University for an Academic Year in excess of two (2) percent of the profits theretofore computed and paid by Operator for such Academic Year. In such later event Operator shall pay the full cost of such audit. Operator

shall promptly furnish University with a copy of any independent audit it obtains for the operations hereunder. If any audit shall determine that there has been a deficiency in the payment of funds due the University, such deficiencies shall be immediately paid to the University by Operator, together with interest at the rate of one and a half (1½) percent per month. University shall have the right, at its expense and at all reasonable time (but no more frequently than annually) to inspect and audit the books and records of Operator.

12.5 Accounting

Operator shall perform all accounting necessary and appropriate for the operations under this Agreement on a cash basis in accordance with generally accepted accounting principles consistently applied, except as otherwise disclosed.

ARTICLE 13

USE OF UNIVERSITY TRADEMARKS

Operator agrees not to use University's name or other trademarks (together referred to herein as the "Marks"), or the name or trademarks of any related organization, or to quote the opinion of any of University's employees or agents ("Quotes"), either in writing or orally, without the prior written consent of the University's Assistant Vice President of Business Development. This prohibition includes, but is not limited to, use of the Marks or Quotes in press releases, advertising, marketing materials, other promotional materials, presentations, case studies, reports, websites, application or software interfaces, and other electronic media.

ARTICLE 14

INDEPENDENT OPERATOR

Operator shall be an independent Operator, and neither Operator nor any employee of Operator shall be, or be deemed to be, an employee of the University.

ARTICLE 15

CONFLICT OF INTEREST

Operator affirms, that to the best of its knowledge, there exists no actual or potential conflict between Operator's family, business or financial interest and the services under this Agreement, and in the event of change in either private interests or services under this Agreement, it will raise with the University any question regarding possible conflict of interest which may arise as a result of such change.

ARTICLE 16

EQUAL OPPORTUNITY

In connection with its performance under this Agreement, Operator will not: (1) discriminate against any employee or applicant for employment because of race, religion, color, sex, age, national origin, or physical or mental disability (unless such disability is job related), and will take affirmative action to insure equal opportunity in all aspects of employment including, but not limited to recruitment,

promotion, demotion, transfer, layoff, termination, compensation and selection for training, including apprenticeship; and (2) will send to each labor union or representative of workers with which it has a collective bargaining agreement or other contract or understanding a notice stating the terms of the commitment hereunder with respect to equal opportunity.

Operator agrees to comply with the following Federal regulations, incorporated herein by reference: FAR 52.222-26 (Equal Opportunity), FAR 52.222-27 (Affirmative Action Compliance for Construction - **applicable to Construction Contracts only**), FAR 52.222-35 (Affirmative Action for Special Disabled and Vietnam Veterans), FAR 52.222-36 (Affirmative Action for Handicapped) and the applicable regulations in 41CFR Part 60.

All applicable and required flow down provisions of the Federal Acquisition Regulations (“FAR”) are hereby incorporated by reference into this Agreement.

ARTICLE 17

ASSIGNMENT PROHIBITED

Operator shall neither assign its rights nor delegate its duties under this Agreement, not any interest therein, without prior written consent of University. This prohibition of assignment and delegation extends to all assignments and delegations that lawfully may be prohibited by agreement.

ARTICLE 18

LAW

This Agreement and all services hereunder shall be governed by the laws of the State of California.

ARTICLE 19

TERMINATION OF AGREEMENT

- 19.1 Either party may terminate this Agreement for its convenience, without penalty or cause, by giving not less than ninety (90) days advance written notice to the other party of the intention to terminate this Agreement and the specific termination date.
- 19.2 University may terminate this Agreement for default provided it gives written notice to Operator of its dissatisfaction with Operator’s performance under the terms and conditions of the Agreement, and provides Operator a minimum of thirty (30) days to correct deficiencies or show cause, as deemed satisfactory by University, why the determination is unjust.

ARTICLE 19

ENVIRONMENTAL HEALTH AND SAFETY

This section applies to all Operators who supply Stanford University with services that are not related to facilities or grounds maintenance, construction, demolition, installation of equipment (including furnishings) or products that contain regulated hazardous materials (including consumer products).

Asbestos: In accordance with California Health and Safety Code Section 25915 (Connelly Act) and the Cal/OSHA Asbestos Standard, 8 CCR Section 1529, Operator is hereby notified that in University facilities there are construction materials that are known to contain asbestos. In some areas, asbestos has been identified in one or more of the following construction products: spray-applied fireproofing; pipe, boiler, tank and air duct insulation; air duct seam tape; gaskets; roofing tar, felt and mastic; asbestos-cement pipe, wallboard, and shingles; plaster and acoustical treatments; gypsum board taping compound; vinyl and asphalt floor tile; vinyl sheet flooring; vinyl flooring, basecove, and ceiling tile adhesive; caulking and glazing compound; acoustic ceiling and wall tile; lab fumehood liners, exhaust ducts and counter tops; and fire-rated door core insulation.

Operator shall not disturb building materials and shall stop work and report any inadvertent disturbance of such materials immediately to Stanford Environmental Health and Safety at 650-725-9999. Unless specifically qualified to do so, Operator shall not enter an area that is posted with warning signs or labels indicating the presence of chemical, biohazardous or radioactive materials or equipment or areas that may have residual contamination from such materials.

Proposition 65 Notice: Under California Health and Safety Code Sections 25249.5 through 25249.13, asbestos, lead, mercury and polychlorinated biphenyls have been listed as chemicals known to the State of California to cause cancer or reproductive harm. Operator will be working in areas in which some or all of these materials may be present. This notice constitutes the warning of the presence of a chemical known to cause cancer or reproductive harm required by Proposition 65. It is Operator's duty to follow all requirements of Proposition 65.

ARTICLE 20
SUSTAINABILITY

20.1 University's 5R Recycling Program

The Stanford Recycling Center is operated by Peninsula Sanitary Services, Inc. ("PSSI"). Operator shall acquaint itself with Stanford's 5R Recycling Program, and shall set up a program of Reduction, Reuse, Recycling, and Composting as outlined in Stanford's 5R Recycling Program, which can be found at: <http://recycling.stanford.edu/5r/index.html>

20.2 Disposable Service Ware

Exhibit "I" covers the "Program and Purchasing Guidelines for Disposable Service Ware Use in Retail Dining Establishments on the Campus of Stanford University". Operator shall acquaint itself with these guidelines and shall only supply Approved Service Ware for "To-Go" orders, in its operation of the Dining Services Program.

20.3 Compost Collection

Exhibit "J" covers "PSSI's Recycle and Compost Collection Program". Operator shall acquaint itself with this Program and shall comply with this Program in its operation of the Dining Services Program.

20.4 Trash, Garbage, Recyclables and Compostables

Operator shall be responsible for gathering and properly containerizing trash, garbage, recyclables, and compostable materials, generated by the provision of the Dining Services Program, and for all Operator-generated trash, garbage, recyclables, and compostable materials, to designated University trash containers, recycling containers, and/or compost containers.

20.5 Operator shall comply with Stanford's Requirements set forth in the attached documents:

Exhibit "K" Special Conditions for Storm Water Pollution Prevention
Exhibit "L" Stanford University's Environmental Health & Safety document

ARTICLE 21

THE AGREEMENT DOCUMENTS

The Agreement Documents consist of the following. . These form the Agreement Documents, and all are fully a part of the Agreement as if attached to this Agreement or repeated herein. The following Agreement Documents are attached hereto (unless otherwise indicated):

- a. This Agreement dated _____, 2011, and its Attachments:
 - Exhibit "A" – Operation Schedule
 - Exhibit "B" – Furniture and Fixtures Owned by University
 - Exhibit "C" – Appliances and Equipment Owned by Operator
 - Exhibit "D" – Floor Map Diagram of The _____ Café area
 - Exhibit "E" – Major Equipment and Fixtures Depreciation Schedule
 - Exhibit "F" – Remit to Addresses
 - Exhibit "G" - Operator's proposal dated April 11, 2011
 - Exhibit "H" – List Of Payment Applications Operator Will Use To Conduct Financial Transactions Under This Agreement
 - Exhibit "I" - Program and Purchasing Guidelines for Disposable Service Ware Use in Retail Dining Establishments on the Campus of Stanford University
 - Exhibit "J" - PSSI's Recycle and Compost Collection Program
 - Exhibit "K" - Special Conditions For Water Discharge Management and Environmental Pollution Prevention
 - Exhibit "L" - Environmental Health & Safety

IN WITNESS WHEREOF, the parties hereto have executed this Agreement in not fewer than two (2) counterparts effective as of the day and year first hereinabove written.

_____.

THE BOARD OF TRUSTEES OF THE
LELAND STANFORD JUNIOR UNIVERSITY

By: _____
Signature

By: _____
Signature

Type Name and Title

Signature Date

IRS Employer Identification Number

Signature Date

Exhibit A
MANAGEMENT AND OPERATION OF
THE _____ CAFÉ

OPERATIONS SCHEDULE

Operator will be open from _____ am – _____ pm, Monday – Friday, except weekdays that are designated as University holidays. The operation can be open additional hours based on demand, including weekend hours, provided advance written permission has been obtained by the Operator from the Contact.

Exhibit B
MANAGEMENT AND OPERATION OF
THE _____ CAFÉ

FURNITURE AND FIXTURES OWNED BY UNIVERSITY

Exhibit C
MANAGEMENT AND OPERATION OF
THE _____ CAFÉ

APPLIANCES AND EQUIPMENT OWNED BY OPERATOR

Exhibit D
MANAGEMENT AND OPERATION OF
THE _____ CAFÉ

FLOOR MAP DIAGRAM OF THE _____ CAFÉ AREA

Total space for Coupa Café Shop: ____ square feet plus ____ square feet storage.

Exhibit E
MANAGEMENT AND OPERATION OF
THE _____ CAFÉ

MAJOR EQUIPMENT AND FIXTURES DEPRECIATION SCHEDULE

Exhibit F

MANAGEMENT AND OPERATION OF
THE _____ CAFÉ

PERTINENT ADDRESS

Remit payments for the following invoices to the address provided below:

Commission Payments:

Contact

Stanford, CA 94305-_____

Email: _____

Phone: (650) _____

Utility Bills:

- Not Applicable

Property Bills:

- University's invoices will provide the remit-to address

Exhibit G
MANAGEMENT AND OPERATION OF
THE _____ CAFÉ

OPERATOR'S PROPOSAL

Exhibit H

MANAGEMENT AND OPERATION OF
THE _____ CAFÉ

LIST OF PAYMENT APPLICATIONS OPERATOR WILL USE TO CONDUCT FINANCIAL
TRANSACTIONS UNDER THIS AGREEMENT

Exhibit I
MANAGEMENT AND OPERATION OF
THE _____ CAFÉ

Program and Purchasing Guidelines for Disposable Service Ware Use in Retail Dining Establishments on
the Campus of Stanford University

STAKEHOLDERS

These guidelines are sponsored by Stanford Hospitality and Auxiliaries (a division of Residential & Dining Enterprises) and are supported by the Associated Students of Stanford University, Students for a Sustainable Stanford, Peninsula Sanitary Services Inc./Stanford Recycling, and the Office of Sustainability.

INTRODUCTION

Over the course of the last several years, Peninsula Sanitary Services Inc. (PSSI)/Stanford Recycling, Stanford University's primary contracted waste management vendor, has worked in partnership with several campus stakeholders to perform fifteen "waste audits" of various waste streams generated on campus. The results of these audits indicate that, on average, 75% (by weight) of campus-generated waste material destined for the landfill could otherwise be recycled, reused, or redirected. Approximately 81% of this otherwise recyclable or reusable material is comprised of mixed paper, organic material, and bottles and cans, for which there are established handling, sorting, and transportation infrastructures and efficient markets in which they can be traded. The remaining 25% of campus-generated waste material represents an opportunity for conversion away from landfill appropriate materials to materials that can be recycled or reused. In the context of these guidelines, this opportunity is represented specifically by the conversion away from single use, disposable serviceware to compostable serviceware. The diversion of these materials from the landfill to value added, "closed loop" waste streams represents a significant opportunity for Stanford University to materially reduce its ecological footprint.

GUIDELINES

Objective

The primary objective of these guidelines is to align all retail food establishments on the Stanford campus towards the goal of generating zero landfill waste. Moreover, these guidelines are intended to provide management with a working framework to achieve this goal by outlining approved disposable serviceware items and the supporting infrastructure that is required to facilitate proper and effective diversion of waste from the landfill. Although these guidelines are specific to disposable serviceware, it should be noted that employment of reusable serviceware is the preferential option for reducing both landfill waste and a dining establishment's overall ecological footprint.

Approved Serviceware

Unless otherwise approved by PSSI, all *non-reusable serviceware*, including cutlery, plates, bowls, hot cups, cold cups, soufflé portion cups, straws, soup containers, boxed and hinged clamshells, deli containers, trays and lids, sandwich bags, food wraps, food displays, and compost bin liners, must be

certified as compostable by the Biodegradable Products Institute (BPI). Acceptable BPI certified items include both manufacturer/distributor branded items that have achieved BPI certification as well as items principally made of branded resins that have been BPI certified. It is important to note that BPI certification applies only to the specific items made by a manufacturer and not necessarily to the manufacturer itself.

Exceptions to BPI Certification

Current exceptions to BPI certification for compostable serviceware include items made of sugarcane bagasse, wheat straw, potato starch, non-laminated paper, and wood.

Purchasing Preferences

When substitutable items of equal performance exist, compostable serviceware items made of co/byproducts, such as bagasse and wheat straw, should be prioritized over those made of first use products, such as corn-based PLA. Similarly, priority should be placed on compostable paper-based items that contain higher percentages of post consumer content over compostable paper-based items with lower, or no, post consumer content.

Current Manufacturer List of BPI Certified Bags and Film

AL-PACK
 Alte-Rego Corporation
 Berry Plastics
 BioBag Canada, Inc.
 BioBag International
 BioBagUSA
 Cortec
 El-En Packaging Company Limited
 Farnell Packaging
 Fortune Plastics
 Glad Manufacturing Co.
 Heritage Bag Company
 Hybrid Packaging Ltd.
 Imaflex, Inc.
 Indaco Manufacturing Ltd.
 Mid-America Bag LLC
 Northern Technologies
 Plastics Solutions
 Poly-America L.P.
 Polykar Industries
 Republic Bag Inc.
 Roplast Industries Incorporated
 S&Q Plastic
 US Compo Solutions
 W. Ralston (Canada)
 Webster Industries

Current Manufacturer List of BPI Certified Foodservice Items

Asean
Biosphere Industries, LLC
Bridge-Gate Alliance Group
CKF Inc.
Dyne-A-Pak, Inc
Eco-Products, Inc
Fabri-Kal Corp
Genpak LLC
GreenGood Inc.
Huhtamaki
International Paper
Kuan Chun Paper Company
McNairn Packaging
Nat-Ur
Permapack AG
PrimeWare/PrimeLink Solutions, LLC
Reynolds Packaging
Solo Cup
Trans-World International (New York) Inc.
VerTerra Ltd.
World Centric

Current Manufacturer List of BPI Certified Resins

BASF
Because We Care Pty, Ltd.
Cardia Bioplastics
Cereplast
Corn Products Brasil Ingredientes
Danimer Scientific
FKuR Kunststoff GmbH
Grace Biotech Corporation
Grenidea Technologies
Guangdong Shangjiu Biodegradable Plastics Co., Ltd.
Heritage Plastics
Kingfa Science & Tech. Co., Ltd.
KUREHA CORPORATION
Minima Technology Co. Ltd
Mitsubishi Chemical Corporation
NatureWorks LLC
Novamont NA
Stanelco
Telles, LLC
Tianan Biologic Material Company (TNN)

Current Manufacturer List of BPI Certified Packaging Materials

Bi-ax International
Clarifoil

Earthcycle Packaging
Fluid Ink Technology
Innovia Films, Inc.
MeadWestVaco
Pace Industries
Pland Paper
Plantic Technologies Limited
Plastic Suppliers
Sealed Air
StarchTech
Storopack

INDOOR BINS & SIGNAGE

In order to facilitate appropriate consumer behavior, dining establishments must provide clearly labeled bins for landfill/trash, cans and bottles, mixed paper, and compostable material. Ideally, such bins should also be appropriately colored to assist in differentiating their intended uses. *Importantly, no landfill/trash bin should be placed in isolation. Landfill/trash bins must always be accompanied by recycling and compost bins in the immediate vicinity.*

OUTDOOR BINS & WASTE SERVICE

Dining establishments should contact Campus Planning to ensure that campus approved recycling and compost bins are situated alongside all landfill/trash bins in common outdoor eating areas. Dining establishments should also contact PSSI to set up and ensure that proper waste service is administered to the location.

AUDITING & REPORTING

A delegation of organized students, represented herein as stakeholders, will administer a regular auditing process to ensure compliance with these guidelines. Auditing will occur unannounced and randomly and the results will be shared with the management of both the dining establishment and of the dining establishment's parent organization and/or management agency.

Exhibit J
MANAGEMENT AND OPERATION OF
THE _____ CAFÉ

PSSI's Recycle and Compost Collection Program

Recycling Bottles and Cans and Paper

We provide our utilitarian bottle and can recycling and mixed paper recycling bins to customers on campus. If cafes would like bins that match their furnishings or environment, they are welcome to provide their own bins with proper signage. If they want us to service their self-supplied recycling bins, then they have to meet our standards for safety and serviceability.

Otherwise their staff can empty their self-supplied bins into one of our utilitarian recycling bins stored somewhere on site or close by. I do maintain a list of recycling bin vendors.

Recycling Cardboard

We provide access to a cardboard recycling dumpster that is located next to the garbage dumpster. Café Operators will likely need to flatten their cardboard and store it at the café until they are ready to walk over to a cardboard recycling dumpster.

Composting Food Waste and Compostable Materials

In addition, we can provide access to a food and compostable material bin that will be located in the garbage and cardboard dumpster enclosure. Here again, the café will likely need to provide its own interior bin for collection and then bring the food waste to our brown wheeled cart at the enclosure.

Here is our website for food and compostable material collection:

<http://recycling.stanford.edu/food/foodindex.html>

It has the requirements for back of counter and front of counter collection at cafes.

Requirements for Food/Compost Collection from Behind the Counter

- Agree to source separate out compostable items from trash (see list).
- Agree to train staff and volunteers on the food waste and recycling program.
- Agree to develop announcements, signage, and other educational material to educate staff, volunteers, and customers on food waste and recycling program.
- Agree to assign staff or volunteers to monitor bins.

Requirements for Food/Compost Collection from Front of Counter

- Agree to purchase only BPI certified compostable serviceware (Biodegradable Products Institute <http://bpiworld.org/BPI-Public/Approved.html>).
- Agree to replace all single-use and/or disposal items with a reusable, recyclable, or compostable option.
- Agree to have equal number of compost and garbage bins and place them next to each other. - Agree to train staff and volunteers on food waste and recycling program.
- Agree to develop announcements, signage, and other educational material to educate staff, volunteers.

and customers attendees on food waste and recycling program.
- Agree to assign staff or volunteers to monitor bins.

Food Waste Bins

We are working to offer access to a food waste compost bin to every café on campus this fall. Going forward, as new cafes start up on campus they will be required to participate in the compost program from the very start.

Public Recycling and Composting Bins

The Planning Department is planning on putting more public recycling and composting bins in the outdoor dining areas at the cafes as well.

To obtain current and new information about the PSSI programs available on campus please contact:

Julie Muir
PSSI/Stanford Recycling
339 Bonair Siding
Stanford, CA 94305
juliem@pssi.stanford.edu
650.321.4236 ext 21
<http://recycling.stanford.edu>

Recycling: It is not just about landfill diversion, it is about replacing virgin material production which will significantly reduce energy consumption and greenhouse gas emissions.

If it can't be reduced, reused, repaired, rebuilt, refurbished, refinished, resold or recycled or composted then it should be restricted, redesigned or removed from production. - Berkeley Ecology Center

Exhibit "K" –
Special Conditions For Water Discharge Management and Environmental Pollution Prevention

- Exhibit "L"
Environmental Health & Safety

ARTICLE 6
UTILITIES, FACILITIES, AND EQUIPMENT

6.1 Utilities

- a. The University will supply heat/air and electrical current necessary for the operation of “Cafe.”
- b. [The Operator will pay for all electrical (including lighting), water and sewage utilities used in “Café”.]
- c. The Operator will pay the monthly phone/fax/computer access charges used in “Cafe.” Operator’s checks for such access charges shall be payable directly to the company providing phone/fax/computer access.
- d. If the Operator wishes to extend the services in ways that require additional electrical capacity, alterations will be made at the Operator’s expense and not prior to having obtained written authorization from the Contact.
- e. The University does not guarantee an uninterrupted supply of electricity heat or air conditioning or other utilities. However, it shall use its reasonable efforts to restore service promptly following an interruption.
- f. Operator shall use reasonable efforts to minimize utility consumption and conserve energy, and shall comply with established energy conservation practices, regulations and policies.

6.2 Sanitation and Safety

- a. Operator shall operate and maintain “Cafe” in a clean, neat and safe condition and warrant that the operation shall comply fully with all relevant federal, state and local laws, codes and regulations, including the acquiring and maintaining of all necessary permits and licenses, and other requirements applicable to University.
- b. To ensure sanitation, health, cleanliness and to maximize customer appeal, Operator shall perform all cleaning and sanitation services necessary to maintain all areas of “Cafe” to the highest standards of sanitation including pest extermination. All tables (interior and exterior) shall be cleared and wiped as needed and in coordination with other vendors offering service in Facility during the hours of operation, and tables and chairs re-positioned as necessary. Operator shall report missing or damaged tables and chairs to the Contact.
- c. University shall provide waste containers in the dining areas in sufficient quantity to maintain sanitary standards for trash disposal. Waste containers inside and outside on the patios shall be kept in a clean and sanitary condition and emptied as often as necessary by Operator. All trash shall be placed in the designated outdoor dumpster by Operator’s staff at end of each business day. All recyclable and biodegradable materials will be placed in appropriate containers at the end of each business day.
- d. Operator shall fully cooperate with all inspectors of state, local and University health departments and safety offices, and such persons shall have access to “Cafe” spaces and all food service, production and storage areas on inspections, which they may conduct. A

copy of any health inspection report shall be furnished to the Contact within 24 hours of the inspection.

- e. Operator hereby agrees to begin implementation, within thirty (30) days of receipt of notice requiring same (or earlier if required by notice), corrective operating measures required or recommended as a result of such health inspections
- f. Nothing contained herein shall obligate or be deemed to obligate University to conduct any inspection of "Cafe" or exercise a particular standard of care in making an inspection. University shall not be liable for failure to make inspections or for failure to observe defects or unsafe conditions or for failure to notify Operator of same or to rectify any defects or conditions.
- g. Operator shall develop and implement a prudent program of accident prevention and safety education. Operator shall provide proper and sufficient instructions and training on the use of equipment and techniques of handling food and beverages to aid in the goal of having an accident-free and safe environment. First aid supplies (provided by Operator), and fire extinguishers and fire alarms (provided by the University) will be available for use as needed. Operator will train employees on where to find them and how to use them. All injuries and accidents are to be reported to the Contact promptly.
- h. Operator shall comply with Stanford's Requirements set forth in the attached documents:
 - Special Conditions for Water Discharge Management and Environmental Pollution Prevention document
 - Environmental Health & Safety document

6.3 Equipment, Furniture, and Fixtures

- a. All furniture and fixtures owned by University, as listed in Exhibit "B" of this Agreement, will be available for Operator's use.
- b. Operator agrees to take reasonable care and provide normal necessary maintenance and repairs of the Stanford-owned equipment and cabinetry in "Cafe," listed in Exhibit "B". Operator will be held financially liable for the damage to University-provided fixtures and cabinetry as a result of Operator negligence. Operator shall return fixtures and cabinetry to the University in good condition satisfactory to the University allowing solely for ordinary wear and tear as is normally and customarily encountered in the industry and for obsolescence.
- c. Operator will be responsible for the purchasing, installation, and maintenance of any necessary appliances above what is provided by the University. All of such Operator-owned assets shall be listed in Exhibit "C" of the Agreement and shall be subject to paragraph (f) below. Contact must approve such appliances in advance of purchase/installation. Any approved appliances must be operated by "Cafe" personnel.
- d. Operator shall provide all of the computer systems and cash registers necessary to operate all aspects of "Cafe."
- e. Except for University-owned equipment and fixtures installed in "Cafe," Operator shall provide and be responsible for all equipment and any additional fixtures necessary to maintain operation. The costs for all such major new equipment and/or additional fixtures

are to be recovered by Operator solely out of its regular revenues received under this Agreement, and must be depreciated over a ___ () year period, and in accordance with the schedule detailed in Exhibit "E." This depreciation schedule is for the sole purpose of determining the purchase price of any specific piece of equipment or fixture, which the University might be interested in purchasing from Operator at the end of the Agreement term(s). In such event, the University will have the option, but not the obligation, to buy back such equipment and/or additional fixture(s) at the un-depreciated value, in accordance with Exhibit "E" and provided Operator gave copies of all invoices for such equipment and fixtures, at the time that the expense was incurred, to the Facilities Contact.

- f. Operator hereby agrees that, at the end of the depreciation schedule in Exhibit "E," the respective equipment and fixtures will become the property of the University, provided the University wishes to retain such equipment and/or fixtures.
- g. Operator shall take such measures as may reasonably be required for protection against loss by pilferage or destruction of any assets in "Cafe."
- h. Operator shall supply all smallware equipment required for the successful operation of "Cafe". Smallware equipment consists of dishware, glassware, flatware, utensils, coffee machines, grinders, soda dispensers and similar loose items necessary for normal operating requirements. All "To Go" containers, cups, and wrappings will be biodegradable whenever possible, or at a minimum recyclable.
- i. Operator shall purchase all paper, cleaning materials, and other supplies required for operation of "Cafe."

6.4 The Facility

- a. "Cafe" is located in _____ and occupies a total of ____ square feet of indoor space.
- b. The Building shall be locked after hours and shall be accessible with the use of I.D. Cards. The Operator will have access to the building as needed and will be responsible for securing "Cafe" facility at the end of each business day.
- c. The facility's management shall have the full right of access to "Cafe" and all areas covered by the Agreement, at any and all times. In no event shall Operator license or in any manner permit any person or entity to use or occupy any such space except as specifically provided in this Agreement and no assignable or transferable property interest is created hereby. "Cafe" locks may only be changed with the prior written authorization of the Contact who will, if authorized, coordinate the change with the University lock shop.
- d. Operator shall not have the right to make temporary or permanent alterations, additions, or renovations to "Cafe" without the Contact's prior written consent, which consent shall not be unreasonably withheld. The Operator may not alter the appearance of the area in any way without his prior written permission.
- e. Operator shall order and pay for Cafe signage. Designs shall be pre-approved by the Contact. Location of signage must be within the ____ square foot space and may not be

outside or above the designated area. Specific location of signage must be pre-approved by the Contact prior to installation.

- f. Operator agrees to arrange for and pay for all electrical or other repairs caused by activities of the Operation.
- g. During the course of this Agreement, University may make renovations to “Cafe”. The University shall provide Operator with prior notice.

Current Housekeeping and Maintenance
Requirement per Contract

Current Housekeeping and Maintenance Requirement Per Contract

Task		Existing Standard Contract	Frequency	Roles & Responsibility	
Utilities	Utilities	Heat/Air is supplied	Yes	As needed	University
		Electricity is supplied	Yes	As needed	University
		Pays for electricity	Yes	Monthly	Operator
		Pays for water	Yes	As needed	Operator
		Pays for Sewage utilities	Yes	As needed	Operator
		Pays monthly phone/fax/computer access	Yes	Monthly	Operator
		Approval needed for extension of services such as additional electrical capacity	Yes	As needed	Operator
		Minimize utility consumption and conserve energy. Complies with established utility conservation practices, regulations and policies	Yes	As needed	Operator
Sanitation and Safety	Space and Furniture Cleanliness	Operates and maintain "Café" in a clean, neat and safe condition and warranty operation complies with all relevant federal, state and local laws, codes and regulations. Acquire all the necessary permits and licenses.	Yes	As needed	Operator
		Clear and wipe all tables (interior and exterior)	Yes	Normal Business Hours	Operator
		Reposition tables and chairs as necessary.	Yes	As needed	Operator
		Report missing or damaged tables and chairs.	Yes	As needed	Operator
	Waste & Recyclables	Clean and empty the waste containers located inside and outside of patios.	Yes	As needed	Operator
		Place all trash in the designated outdoor dumpster	Yes	End of business day	Operator
		Place all recyclable and biodegradable (compost) materials in appropriate containers	Yes	End of business day	Operator
	Inspections	Cooperate with inspectors from all state, local, University health departments and safety persons	Yes	As needed	Operator
		Furnished a copy of the inspection report to the University	Yes	within 24 hours	Operator
		Begin implementation of corrective action per requirement of inspection report	Yes	within 30 days of notice	Operator
	Safety	Develop a program of accident prevention and safety education training.	Yes	Required	Operator
		Provide first aid supplies.	Yes	As needed	Operator
		Provide fire extinguisher and fire alarms	Yes	As needed	University
		Train employees on where to find and how to use fire aid supplies, fire extinguisher and fire alarms.	Yes	Required	Operator
		Notify University of all injuries and accidents.	Yes	As needed	Operator
		Comply with Stanford's Requirements: 1) Special Condition for Water Discharge Management and Environmental Pollution Prevention Document 2) Environmental Health and Safety Document	Yes	Required	Operator
University furnished equipment	Provide normal necessary maintenance on equipment provided by the University.	Yes	As needed	Operator	
	Financially liable for damage to University provided fixtures and cabinetry as a result of Operator negligence.	Yes	As needed	Operator	
	Return fixtures and cabinetry to University in good condition per normal wear and tear.	Yes	As needed	Operator	

Equipment, Furniture and Fixtures	Operator furnished equipment	Approve all additional appliances provided by Operator prior to purchase/installation	Yes	As needed	University
		Be responsible for purchasing, installation and maintenance of all necessary appliances above what is provided by the University.	Yes	As needed	Operator
		Provide all computer systems and cash registers.	Yes	As needed	Operator
		Responsible for the maintenance of all non University supplied equipment and fixtures.	Yes	As needed	Operator
		Provide cost for all additional equipment and fixtures. Cost will be depreciated over a time period so the University has an option to own at the end of the agreement term.	Yes	As needed	Operator & University
		Provide all small ware such as dishware, glassware, flatware, utensils, coffee machines, grinders, soap dispensers.	Yes	As needed	Operator
		Provide all To Go containers, cups and wrapping in biodegradable whenever possible or at a minimum recyclable.	Yes	As needed	Operator
		Provide all paper, cleaning materials and other supplies.	Yes	As needed	Operator
		Operator's personnel shall operate approve appliances	Yes	As needed	Operator
		Facility	Access & Security	have access during after hours by way of ID cards.	Yes
Securing the "Café" facility	Yes			End of business day	Operator
Coordinate all lock changes with University for authorization and to coordinate with the University Lock Shop.	Yes			As needed	Operator & University
have full right access to the "Café" at all times	Yes			As needed	University
Renovations	Not have the right to make temporary or permanent alteration, additions, or renovations without authorization from the University.		Yes	As needed	Operator & University
	Not alter the appearance of the area in any way without authorization from the University.		Yes	As needed	Operator & University
	Order and pay for Café signage.		Yes	As needed	Operator
	Obtain pre-approval from University on designs.		Yes	As needed	Operator & University
	Obtain pre-approval from University for location of signage.		Yes	As needed	Operator & University
	Pay for all electrical and other repairs caused by activities of the Operation.		Yes	As needed	Operator
	University has right to make any renovations to the "Café". Prior notice will be given to the Operator.		Yes	As needed	Operator & University

List of On-Site Food Establishment

On-site Food Establishment Inventory as of 08/06/2013

ID	Group	Location	Building Quad	Address
1	Academic	Thai Café	01-420	450 Serra Mall, Rm 48
2	Academic	Stanford Bookstore Café	02-010	519 Lasuen Mall
3	Academic	Jamba Juice	02-300	459 Lagunita Drive
4	Academic	CoHo	02-300C	459 Lagunita Drive
5	Academic	Treehouse	02-300T	459 Lagunita Drive
6	Academic	Faculty Club	02-350	439 Lagunita Drive
7	Academic	Coupa Café (Green Library Kiosk)	03-225	571 Escondido Mall
8	Academic	Cubberley Café	03-300	485 Lasuen Mall
9	Academic	Bytes Café	04-030	350 Serra Mall
10	Academic	Coupa Café (Y2E2)	04-070	473 Via Ortega Mall
11	Academic	Ike's Place	04-080	475 Via Ortega Drive
12	Academic	Coupa Café (HEC)	04-080	475 Via Ortega
13	Academic	Cool Café	07-100	328 Lomita Drive
14	Academic	Nexus Café (Clark Center)	07-340	318 Campus Drive
15	Academic	Peet's Coffee & Tea	07-340	318 Campus Drive
16	Academic	Arbuckle Dining Pavilion	08-050	655 Knight Way
17	Academic	Coupa Café (GSB)	08-050C	655 Knight Way
18	DAPER	Jimmy V's Sports Café	09-307	641 Campus Drive
19	DAPER	Coupa Café (Golf Course)	12-010	198 Junipero Serra Blvd.
20	Dining	Lagunita Dining Hall	05-010G	326 Santa Teresa Street
21	Dining	Florence Moore Dining Hall	05-200H	436 Mayfield Avenue
22	Dining	Murray (aka American Studies)	05-712	566 Governor's Avenue
23	Dining	Yost	05-714	574 Governor's Avenue
24	Dining	Ricker Dining Hall	05-750E	238 Santa Teresa Street
25	Dining	Branner Dining Hall	06-100	655 Escondido Road
26	Dining	Arrillaga Family Dining Commons	06-250	489 Aguello Way
27	Dining	Wilbur Dining Hall	06-400K	658 Escondido Road
28	Dining	Stern Dining	06-500K	618 Escondido Road
29	Dining	Manzanita Park Dining Hall	06-710	661 Escondido Road
30	Dining	Schwab Center Dining Hall	06-750E	680 Serra Street
31	Dining	Maples Pavilion	09-300	655 Campus Drive
32	Dining	Sunken Diamond	09-362	151 Sam McDonald Mall
33	Dining	Stanford Stadium	09-505	625 Nelson Road
34	Hospitality & Auxiliaries	Olive Café	01-160	450 Serra Mall
35	Hospitality & Auxiliaries	Law School Café	02-050	559 Nathan Abbott Way
36	Hospitality & Auxiliaries	Russo Café (Munger Bldg 4)	02-070D	555 Salvatierra Walk
37	Hospitality & Auxiliaries	Panda Express	02-300	459 Lagunita Drive
38	Hospitality & Auxiliaries	Starbucks	02-300	459 Lagunita Drive
39	Hospitality & Auxiliaries	Union Square	02-300	459 Lagunita Drive
40	Hospitality & Auxiliaries	Fraiche Yogurt	02-300FP	459 Lagunita Drive
41	Hospitality & Auxiliaries	Subway	02-300S	459 Lagunita Drive
42	Hospitality & Auxiliaries	Axe & Palm	02-580	520 Lasuen Mall
43	Hospitality & Auxiliaries	Alumni Café	08-450	326 Galvez Street
44	School of Medicine	Always Café	07-307	300 Pasteur Drive
45	School of Medicine	Med Café at LKSC	07-515	291 Campus Drive
46	School of Medicine	Café DNA	07-520	299 Campus Drive
47	School of Medicine	Beckman Bistro	07-530	279 Campus Drive
48	School of Medicine	Lutticken's Deli	07-590	269 Campus Drive
49	Student Housing	Mars	02-914	553 Mayfield Avenue
50	Student Housing	Muwekma-Tah-Ruk (aka Lathrop)	02-920	543 Lasuen Mall
51	Student Housing	Storey	02-921	544 Lasuen Mall
52	Student Housing	Sigma Chi	02-922	550 Lasuen Mall
53	Student Housing	Columbae	02-925	549 Lasuen Mall
54	Student Housing	Sigma Nu	02-926	557 Mayfield Avenue
55	Student Housing	Theta Delta Chi	05-410	675 Lomita Drive
56	Student Housing	680 Lomita	05-430	680 Lomita Drive
57	Student Housing	Sigma Alpha Epsilon (SAE)	05-440	1047 Campus Drive
58	Student Housing	Kappa Sigma	05-450	1035 Campus Drive
59	Student Housing	Lambda Nu (aka Jerry)	05-520	658 Lomita Court

60	Student Housing	Kappa Alpha	05-530	664 Lomita Court
61	Student Housing	Enchanted Broccoli Forest (EBF)	05-540	1115 Campus Drive
62	Student Housing	Narnia	05-550	1135 Campus Drive
63	Student Housing	Moore (Robert S) South (aka BOB)	05-600	566 Mayfield Avenue
64	Student Housing	Moore (Robert S) North (aka La Casa Italiana)	05-610	562 Mayfield Avenue
65	Student Housing	Xanadu	05-620	558 Mayfield Avenue
66	Student Housing	Treat (aka East House)	05-710	554 Governor's Avenue
67	Student Housing	Middle Earth	05-740A	591 Los Arboles Avenue
68	Student Housing	Avanti	05-740B	591 Los Arboles Avenue
69	Student Housing	Bollard	05-740C	591 Los Arboles Avenue
70	Student Housing	Beefeater	05-740D	591 Los Arboles Avenue
71	Student Housing	Graduate Community Center (Ray's Grill)	10-590	750 Escondido Road
72	Student Housing	Kappa Alpha Theta	10-610	585 Cowell Lane
73	Student Housing	ZAP (Zeta Alpha Phi)	10-620	710 Bowdoin Street
74	Student Housing	Delta, Delta, Delta (Tri-Delt)	10-630	702 Bowdoin Street
75	Student Housing	Pi Beta Phi	10-640	517 Cowell Lane
76	Student Housing	Terra	10-650	539 Cowell Lane
77	Student Housing	Chi Theta Chi	11-100	576 Alvarado Row
78	Student Housing	Hammarskjold	11-120	592 Alvarado Row
79	Student Housing	Slavianskii Dom	11-160	650 Mayfield Avenue
80	Student Housing	Phi Sigma	11-190	1018 Campus Drive
81	Student Housing	Grove Mayfield	11-200	584 Mayfield Avenue
82	Student Housing	Kairos	11-210	586 Mayfield Avenue
83	Student Housing	Phi Kappa Psi	11-220	592 Mayfield Avenue
84	Student Housing	La Maison Francaise (aka French House)	11-230	610 Mayfield Avenue
85	Student Housing	Haus Mitteleuropa	11-240	620 Mayfield Avenue
86	Student Housing	Durand	11-260	634 Mayfield Avenue
87	Student Housing	Synergy (aka Cooksey)	11-270	550 San Juan Street
88	Student Housing	Roth	11-280	713 Santa Ynez Street
89	Student Housing	Theta Xi (aka 717 Dolores)	11-290	717 Dolores Street

Appendix

Team Members

Special thanks to the team the following team members who helped create and review this binder

- School of Engineering.
- School of Medicine.
- School of Humanitarian & Science.
- Knight Management Center.
- Stanford Dining.
- Stanford Hospitality.
- DAPER.
- Stanford in Washington.
- DPM.
- SEM.
- Contract Services (DTZ, PSSI).
- Procurement.
- Plumbing Shop.
- HVAC Shop.
- Electrical Shop.
- Grounds.
- Arup.
- Zones Management.



MEMBER OF:



LOCATION

INDIRECT WASTE SOLIDS INTERCEPTOR

FUNCTION: Open top solids interceptor provides a means of collecting food solids from a indirect waste discharge line before entering the drain line going to a grease interceptor.

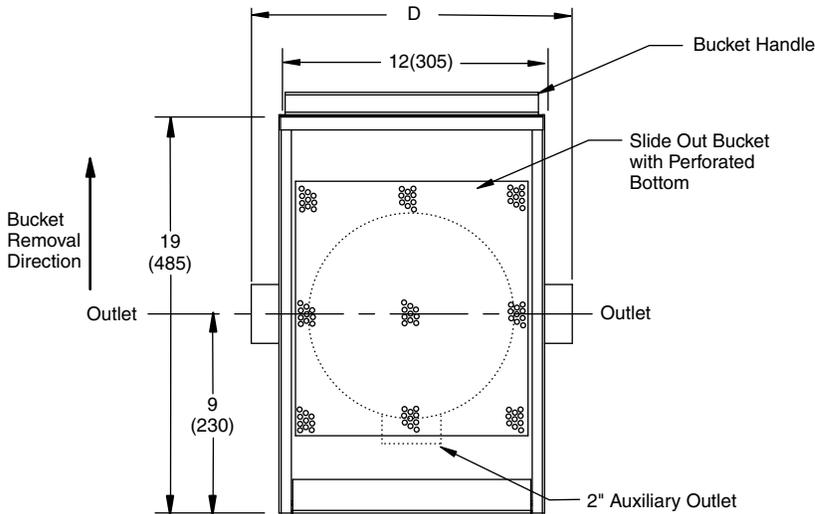

NOTE: Allow 19(485) of clearance on bucket removal side of interceptor for bucket removal. Also allow 6(150) of clearance above interceptor for secondary mesh strainer removal.

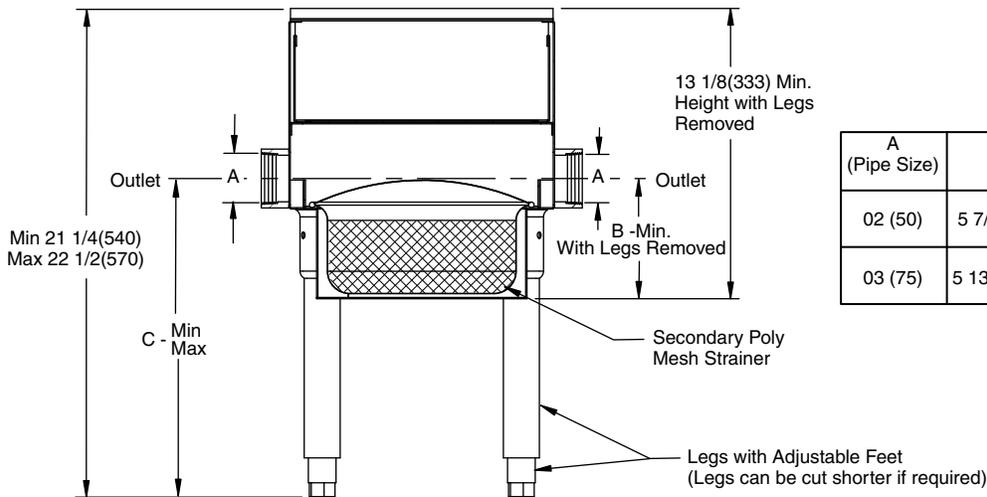

A (Pipe Size)	B	C Min Max	D
02 (50)	5 7/16 (138)	13 1/2 (345) 14 7/8 (378)	14 1/2 (370)
03 (75)	5 13/16 (148)	13 7/8 (353) 15 1/4 (390)	15 1/4 (390)

A (PIPE SIZE) = 02(50) OR 03(75)
 FIG. 8960T.....Threaded Connections

REGULARLY FURNISHED:
 Fabricated Type 304 Stainless Steel Body with Adjustable Legs, Perforated Bottom Bucket, and Secondary Poly Mesh Strainer.

VARIATIONS:
 "Y" No-Hub Connections

See reverse side for illustration of interceptor components.

DRAWING NUMBER
s8960

SIZE
A

SCALE:
NONE

DATE:
6-1-06

APPROVED BY:
CEL

CHECKED BY:
CL

DRAWN BY:
RN

8960

WE CAN ASSUME NO RESPONSIBILITY FOR USE OF SUPERSEDED OR VOID DATA

DIMENSIONS ARE SUBJECT TO MANUFACTURERS TOLERANCE AND CHANGE WITHOUT NOTICE

FIGURE NUMBER

REV.	DATE	DESCRIPTION	BY	CKD. BY

WEIGHT POUNDS

VOLUME CUBIC FEET

FIGURE NUMBER

8960



JAY R. SMITH MFG. CO.
 DIVISION OF SMITH INDUSTRIES, INC.
 POST OFFICE BOX 3237
 MONTGOMERY, ALABAMA 36109-0237 (USA)
 TEL: 334-277-8520 FAX: 334-272-7396 www.jrsmith.com



MEMBER OF:



LOCATION

INDIRECT WASTE SOLIDS INTERCEPTOR

DRAWING NUMBER
s8960BS

SIZE
A

SCALE:
NONE

DATE:
4-11-06

APPROVED BY:
CEL

CHECKED BY:
CL

DRAWN BY:
RN

WE CAN ASSUME NO RESPONSIBILITY FOR USE OF SUPERSEDED OR VOID DATA

DIMENSIONS ARE SUBJECT TO MANUFACTURERS TOLERANCE AND CHANGE WITHOUT NOTICE

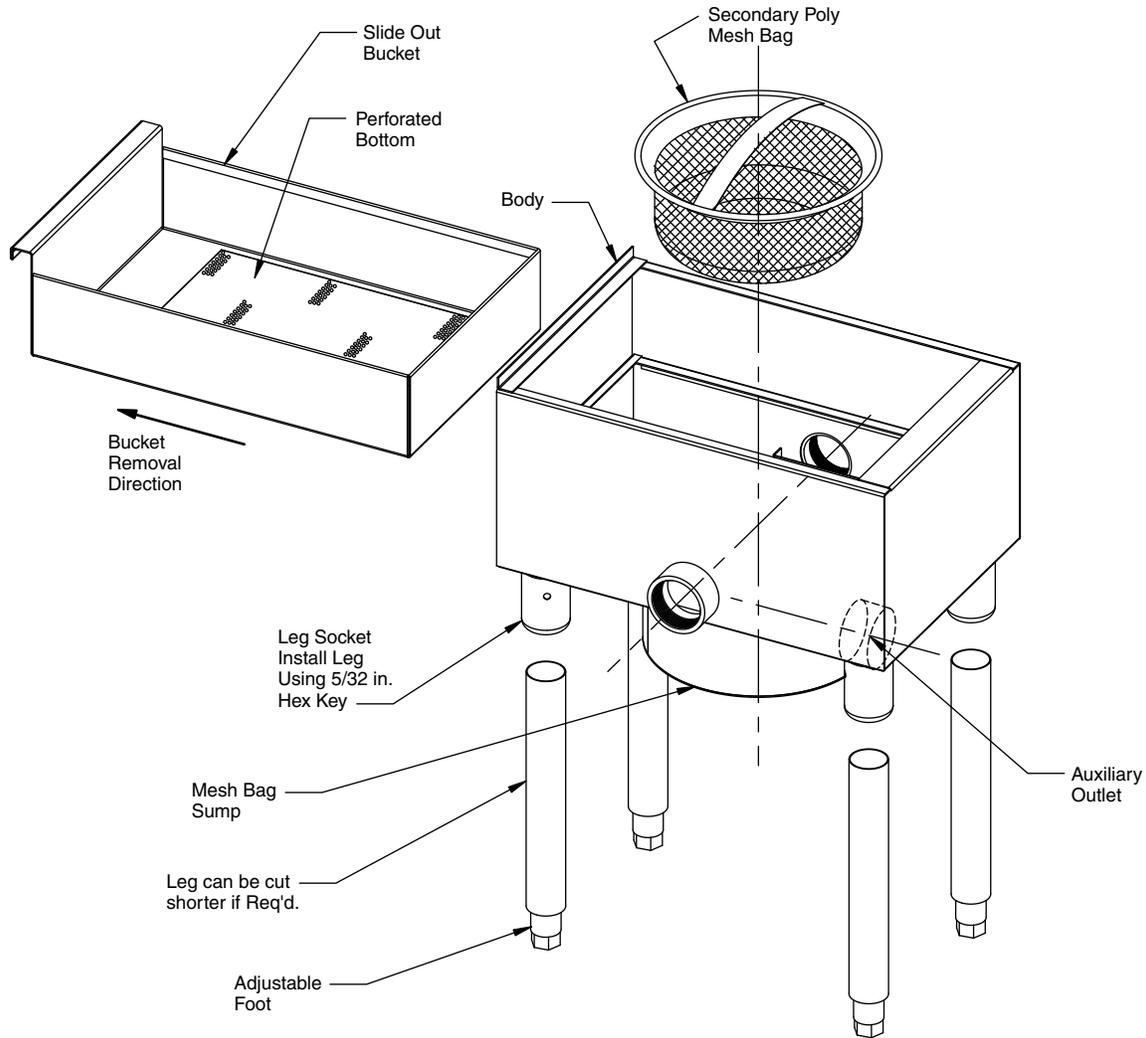

8960

FIGURE NUMBER

REV.	DATE	DESCRIPTION	BY	CKD. BY

WEIGHT POUNDS

VOLUME CUBIC FEET

FIGURE NUMBER

8960

**STANFORD UNIVERSITY
FACILITIES DESIGN GUIDLINES**

SECTION 15405

FATS, OILS AND GREASE WASTE MANAGEMENT SYSTEMS

PART 1-GENERAL

1.1 INTRODUCTION

- A. This specification provides guidelines for the design of the fats, oils and grease waste (FOG) management systems. It provides design criteria, requirements, guidelines for methods, products and components necessary for complete systems.
- B. FOG systems are designed to comply with Palo Alto Ordinances, Santa Clara County Code and public health requirements and State plumbing code and requirements. All project managers should confirm the latest applicable code requirements for their projects prior to submission of any project deliverable.
- C. All buildings with food and beverage service areas shall include a gravity grease interceptor located outside of the building. In addition, buildings with cooking or hot beverage service shall provide a FOG disposal system to capture FOG as close to the source as possible.
- D. Deviations from the requirements in this specification shall be reviewed with Stanford Facilities staff prior to submission of any project deliverable.

1.2 DEFINITIONS

- A. Food Service Establishment: means a facility defined in the California Uniform Retail Food Service Establishments Law (CURFFL) Section 113785, and any commercial entity within the boundaries of the City, operating in a permanently constructed structure such as a room, building, or place, or portion thereof, maintained, used, or operated for the purpose of storing, preparing, serving, or manufacturing, packaging, or otherwise handling food for sale to other entities, or for consumption by the public, its members or employees, and which has any process or device that uses or produces FOG, or grease vapors, steam, fumes, smoke or odors that are required to be removed by a Type I or Type II hood, as defined in CURFFL Section 113785.

1.3 REFERENCES AND STANDARDS

- A. The following references and standards shall be consulted and appropriate provisions incorporated into the design.

1. Codes and standards:
 - a. Palo Alto Sewer Ordinance (PASO) Section 16.09
 - b. California Plumbing Code.
 - c. Applicable rules and regulations of Palo Alto and Santa Clara County

2. Additional Standards:
 - a. ANSI American National Standard Institute
 - b. ASME American Society of Mechanical Engineers
 - c. ASTM American Standards for Testing and Materials
 - d. ASSE American Society of Sanitary Engineers
 - e. AWWA American Water Works Association
 - f. IAPMO International Association of Plumbing and Mechanical Officials
 - g. NBS National Bureau of Standards
 - h. NFPA National Fire Protection Association
 - i. PDI Plumbing and Drainage Institute
 - j. UL Underwriter's Laboratory

3. Water Environment Research Foundation (WERF)
 - a. FOG Interceptor Design and Operation Guidance Manual

1.4 QUALITY ASSURANCE

A. Designer's responsibilities:

1. In order to comply with the PASO design teams shall review and provide calculations for sizing the gravity grease interceptor using the methodology provided in the code.
2. The design team shall provide a second calculation for sizing the grease interceptor based on one of the following:
 - a. Number of meals served per hour
 - b. Engineered calculation of flow rate
 - c. Grease capture device manufacturer's recommended method.
3. The design team shall include devices that shall capture grease at the generating fixture or group of fixtures to reduce the quantity of grease laden sewage going to the exterior gravity grease interceptor. As a minimum the following fixtures shall be connected to a local grease capture device:
 - a. Pre-rinse sink
 - b. 3 compartment pot wash sinks
 - c. Drains serving kettles, tilt/braising pans, wok stoves, rotisserie ovens and broilers.
4. A mop closet must be installed and connected to the grease control system for cleaning kitchen equipment such as floor mats, containers, exhaust hood filters, or other equipment. The space must be large enough to clean the largest piece of equipment.

- B. Manufacturer's Qualifications: Firms regularly engaged in the manufacture of plumbing systems products, of types, materials, and sizes required, whose products have been successfully installed on similar projects for a minimum of 5 years.
 - 1. Stanford Facilities Staff may permit products that do not comply with this requirement. Submit manufacturer's product literature for review and approval.
- C. Installer's Qualifications: Firm with at least 5 years of successful installation experience on similar projects.
- D. Manufacturer's Instructions: Manufacturer's instructions shall be followed where the manufacturers of the components used in the water feature have been provided.

1.5 WORK RESPONSIBILITIES

- A. Coordinate the work with other trades.
- B. Verify the location of all existing utilities prior to construction and protect from damage.
- C. Install pipe with necessary offsets and fittings to maintain required accessibility, and satisfy the University's Representative.
- D. Provide complete functioning systems and include all necessary components required for the FOG system to operate safely and satisfactorily.
- E. Provide work indicated on the Drawings whether or not specifically mentioned in the Specifications.

1.6 SUBMITTALS - REFERENCE SECTION 01330

- A. Designers shall submit with project deliverables at each milestone the following items:
 - 1. A schedule of all kitchen equipment indicating if it shall be connected to sanitary or grease waste systems
 - 2. Cut-sheets for proposed grease capture devices and FOG disposal systems
 - 3. Calculations used for sizing FOG disposal system and the gravity grease interceptor.
- B. In addition to the requirements of Section 01330 Submittal Procedures, a complete schedule of equipment installed, together with drawings that identify the locations of FOG system devices shall be submitted to the Project Manager.
- C. Operation and Maintenance Manual: Prepare and deliver to the University's Representative prior to acceptance of the Work, in ring binders containing the following information:

1. Catalog and parts sheets on every material and equipment installed under this Contract.
2. Complete operating and maintenance instructions for all major equipment.
3. Recommended inspection and maintenance schedule.
4. Complete and dated warranties for all materials used.

1.7 PRODUCT DELIVERY, STORAGE AND HANDLING

- A. All pipe and appurtenances shall be loaded for delivery in such a manner as to avoid scratches or damage to the pipe or appurtenances.
- B. Delivery of pipe and other equipment to the site of the work shall not take place until immediately prior to installation.
- C. All pipe and other equipment and materials shall be handled with care to avoid scratches and damage. Piping shall be protected from damage during installation.
- D. Replacements: In the event of damage, immediately submit a repair and replacement plan to the University's representative for approval. Make all repairs and replacements necessary and demonstrate compliance to the University's Representative prior to concealing or covering work.

PART 2 -PRODUCTS

2.1 GENERAL

- A. FOG systems may be of three types: passive gravity interceptors, hydromechanical grease interceptors, or grease removal systems.

2.2 PASSIVE GRAVITY INTERCEPTORS

- A. Pre-cast concrete, plastic or fiberglass grease interceptor. Minimum capacity 500 gallons. Modify the inlet piping design and baffle design to meet the recommendations of the WERF report.
- B. Coat interior of pre-cast concrete grease interceptors with a corrosion resistant material specifically designed to resist corrosion by hydrogen sulfide.
- C. Manufacturers: Jensen Pre-cast

2.3 HYDROMECHANICAL GREASE INTERCEPTORS

- A. Coated steel, polyethylene or fiberglass grease interceptors that are sized based on flow rate. Traffic rated cover with vandal resistant secured access ports for inspection and grease removal.
- B. Manufacturers: JR Smith, Thermaco

2.4 GREASE REMOVAL SYSTEMS

A. Skimming types

1. Automatic devices that remove grease that floats on the top of the collector are permitted when located within the food service establishment.
2. Manufacturers: Thermaco

B. Grease Digestion Systems

1. Systems use bacteria to digest the grease must be submitted for pre-approval by the city and the University's Facilities Staff.
2. Manufacturers: JR Smith

2.5 PROHIBITED COMPONENTS AND SYSTEMS

A. Grease removal systems that rely on enzymes, emulsifiers, or saponification are not permitted.

B. Heat Trace: The design of the grease waste system shall be as short as possible. Heat trace systems are not permitted.

1. Grease capture devices that use an integrated heating system to transfer grease from the collection to storage component may be used if submitted for approval to University's Facilities Staff.

C. No high temperature discharge lines can be connected to a grease removal system. At a minimum the following fixtures cannot connect to a grease removal system; dishwashers, steamers, hand washing sinks and pasta cookers.

D. No food grinders (disposers) can be installed in food service establishments.

2.6 PIPE MARKERS

A. Label each fixture and drain that is connected to grease waste.

B. Self-sticking pipe markers consisting of pipe content wording and arrow indicating direction of flow on ANSI color background shall be provided for all grease waste and vent piping.

PART 3 -EXECUTION

3.1 GENERAL

A. Prior to all work in this Section, carefully inspect the installed work of other trades and verify that all such work is complete to the point where this installation may properly commence.

- B. Provide materials in sufficient quantities on the job site to complete work and to accommodate minor unforeseen changes and additions in the scope of work.
- C. Include a strainer before the inlet of any FOG removal device to capture food scraps and other components of the waste stream that would prevent normal operation of the FOG removal device.
- D. The contractor shall submit a sewer inspection report for all kitchen waste lines at the end of the construction before handover. The inspection report shall include a video log of each waste line. The inspection shall include a test of each kitchen waste line to confirm drain termination location (sanitary or grease).

3.2 PIPING

- A. Thoroughly clean all pipe and maintain in such condition throughout construction.
- B. Temporarily cap open ends of incomplete pipe work at the end of each work day.
- C. Install exposed piping parallel to, or at right angles with building walls, and install close to walls or ceilings when possible.
- D. Arrange piping and hangers, supports, and bracing to allow for expansion and contraction.
- E. Install piping free from traps and air pockets, and true to line and grade.
- F. Buried piping shall be installed on a 4" layer of sand to provide uniform support of the pipe.
- G. Perform pipe backfilling in conformance backfilling and bedding specifications.

3.3 PIPE TESTING

- A. Perform tests in accordance with the California Plumbing Code, PASO and AWWA standards.

SECTION 01330

SUBMISSION REQUIREMENT GUIDELINES

PART 1 GENERAL

1.01 OVERVIEW

A. University Plans Review Process:

1. The process by which the Designer's schematic, design development, and construction documents and estimates are reviewed and approved is the University Plans Review Process. This occurs at or near the completion of each design phase and is handled by the University's Project Manager by distributing plans and specifications to the interested departments for review and comments. These comments, if any, are then transmitted to the Project Manager for consideration, response, and discussion with the Project Team prior to incorporation. The time required for this process will vary with the complexity of the project, but can ordinarily be expected to take two or three weeks for each stage. The number of sets of plans to be provided by the Designer is covered in the Owner/Architect or Owner/General Contractor Agreement.
2. The review stages are identified as follows:
 - a. 100% Schematic Design submissions
 - b. 100% Design Development submissions
 - c. 50% Construction Documents submissions
 - d. 100% Construction Documents submissions
3. The University Plans Review Process is the key administrative device used by staff to verify that the project is being designed in accordance with Stanford University Facilities Design Guidelines. All deviations from these Guidelines shall be explicitly pointed out and discussed with the University's Project Manager prior to submittal for review, and that such deviations be approved in writing by the University's Project Team before incorporation into the project.
4. Submit plans for review along with the completed Plans Review Transmittal form to Maps and Records as stated in http://maps.stanford.edu/plans_review

B. Presentation Format:

1. Drawings:
 - a. All drawings must have the following minimum identification in the lower right hand corner: Project name, Stanford project number, date (including current revision, if any), quad, building number and address (provided by Stanford) and the appropriate drawing number and drawing identifications (i.e., first floor elevations, etc.). The Designer may use a title block along the right hand margin, but the above minimum information must appear in the lower right hand corner of the sheet to aid in identification and retrieval of drawings from flat file cabinets.
 - b. The drawings shall be on the same size format, for each project. Maximum overall sheet size shall not exceed size E, 42 inch by 30 inch. Only standard, un-reduced sheet sizes D and E will be accepted, without prior approval of Project Manager.

Stanford University-Facilities Design Guideline

2. Specifications shall follow the Construction Specifications Institute format and indexing. The first page of each of Divisions 15, 16, and 17 shall be an index to that section. Use dividers to separate specification sections at least as follows:
 - a. Legal (Invitation to Bid, Instruction to Bidders, Proposal, Agreement, General Conditions, Addenda, Etc.)
 - b. Special Conditions, Construction Administration Procedures
 - c. Architectural (Div. 1-14)
 - d. Mechanical (Div. 15)
 - e. Electrical (Div. 16)
 - f. Communication Services (Div. 17)Note: at least one copy of the specifications shall be submitted in loose, unbound, unpunched format, for ease of reproduction.
3. CAD (Computer Aided Design) submissions: Unless otherwise directed by the Project Manager, a set of drawings for all applicable disciplines shall also be submitted in CAD form. CAD Submittals are required for at least the 50% Construction Document, 100% Construction Document, and As-Built Record Drawing phases, but may not be required for the other design phases (as determined by the Project Manager). Submittals shall comply with the requirements listed at:
<http://maps.stanford.edu/delivering>

C. Project Manual

1. The Project Manual serves as the repository of certain design submissions and other types of information about the project. The production of the Project Manual is the responsibility of the Designer. Sample information that should be included in the Project Manual is as follows:
 - a. MEPS Basis of Design Narratives with load requirements and distribution plan
 - b. Soils Report
 - c. Occupant Loads
 - d. Designed Floor Loading
 - e. Special Conditions Applicable to Future Renovation

- D. Auxiliary Materials: During the normal course of any project, the consultant often submits auxiliary material for the client's information and/or approval. Examples are sketches, overlays, catalog cuts, details, addenda, etc. Since the University handles many simultaneous projects, it is vital that such submitted material be adequately and uniquely identified. Each auxiliary item submitted must have the following minimum identification in the lower right-hand quadrant: Project title, Project Manager's name, Stanford project number, building name, date (including current revision, if any) and appropriate drawing or sketch number.

1.02 SCHEMATIC DESIGN SUBMISSIONS

A. General:

1. At the completion of this stage, the University gives the basic approval to the design from which all further work will flow. This involves, in addition to the Buildings and Grounds Maintenance Department, Utilities Division, the client Department, the University Committee on Land and Building Development, as well as others. Notice to Proceed to the next project phase is given by the Project Manager in order to provide for ease of review.
2. Graphic material for presentations (plans, elevations, renderings, flow diagrams, etc.) should be temporarily affixed to 30 inch by 40 inch rigid, light-weight boards in a

Stanford University-Facilities Design Guideline

demountable manner. It is important that drawings not be permanently affixed to such boards so as to permit their subsequent permanent filing. Because of customary orientation with campus maps, site plans should be presented with north pointing down. Floor plans shall follow orientation of the site plan. Each drawing should also contain appropriate title information (name of project, scale, date, etc.). Colors and exterior materials should be identified to permit staff evaluation as to design intent and compatibility with the overall campus scheme.

B. Minimum Submission Data

1. Title Page: The information listed below, shall be shown on the title page of the drawings.
 - a. Type of Construction
 - b. Occupancy Classification
 - c. Applicable Building Codes:
 - 1) Architectural
 - 2) Structural
 - 3) Mechanical
 - 4) Electrical
 - 5) Plumbing
 - 6) Other
2. Floor plans, typical cross sections, elevations, and general site development should be drawn at a scale which, in the Designer's opinion, most appropriately describes the design intent (1/8 inch or 1/16 inch is suggested). These should be so arranged so that each drawing is complete unto itself without the need to match two or more adjoining drawings.
3. A utility site plan at a scale of 1 inch equals 40 feet is required, with all connections to existing campus lines shown thereon.
4. A campus site plan, indicating relationships between existing campus features and the new development. This site plan should indicate accurately all significant existing features of the site, including buildings, trees, paths, roads, etc.
5. An eye level color rendering representing the most typical exterior view and character sketches necessary to describe the project. Exact requirements should be discussed with the University's Project Manager.
6. Written description of subsurface investigation results (if available), structural systems, and mechanical and electrical utilities.
7. Descriptive information of unusual design characteristics not documented elsewhere.
8. Outline specification for project as follows:
 - a. Outline/Table of Contents for Architectural Sections (Div. 1-14).
 - b. Outline/Table of Contents for Mechanical sections (Div. 15).
 - c. Outline/Table of Contents for Electrical (Div. 16).
 - d. Communications (IT and telephone)
 - e. Fire Protection
9. Tabulation of building areas--net and gross square feet.
10. Statement of Probable Construction Costs.
11. Project Summary Statement. This is a brief review of the entire project and can be used by Stanford in preparing press releases, briefing sessions, summaries for the Board of Trustees, and for other similar purposes. Normally a two or three page statement will be sufficient. Although the Designer will determine the content of the Summary Statement to assure that it conforms to the above, items to be covered should include the following:

Stanford University-Facilities Design Guideline

- a. Purpose of the project and key design elements incorporated to achieve the intended purpose, special site considerations and building areas.
 - b. Outline of materials and any special methods of construction to be employed (prefabricated elements, long lead time pre-ordering, etc.). Include exterior and interior finishes, construction techniques, mechanical and electrical systems, and site work. Describe any unique building systems to be employed, energy conservation methods contemplated, special maintenance requirements (window washing, wall and floor maintenance, etc.), etc.
 - c. Description of construction operations (such as phased construction), special temporary or permanent traffic routing, utility provisions, and overall project schedule. Include any other special project features not otherwise noted.
12. Schematic diagrams of mechanical systems, including air distribution, piping, and control systems. For specific requirements, refer to Section 15200: Special Process Piping Systems, Section 15051: Plumbing Systems, and Section 15050: Heating, Ventilating, and Air Conditioning Systems.
 13. Electrical single-line distribution diagrams.
 14. Schematic data for lighting systems. For specific requirements, refer to Section 16500: Lighting.
 15. Design calculations for mechanical, plumbing and electrical systems. For specific requirements, refer to the appropriate mechanical and electrical sections of these Guidelines.
 16. Basis of Design
 17. MEP Quick Guide Comments Form
 18. Outline Commissioning Strategy Plan (if applicable)
 19. Facility Design Specifications – itemize all differences which takes exception from Stanford’s Facility Design Guideline.

1.03 DESIGN DEVELOPMENT SUBMISSIONS

A. Minimum Submission Data:

1. Architectural and structural drawings indicating foundation and structural requirements, floor plans, room finishes, elevations, cross sections, fixed equipment layout, and others should be drawn to the scale of the final working drawings.
2. A utility site plan at a scale of 1 inch equals 40 feet is required with all connections to campus sources shown.
3. Mechanical:
 - a. Plumbing (refer to Section 15410: Plumbing Systems)
 - b. HVAC (refer to Section 15050: HVAC Systems)
 - c. Special Process Piping (refer to Section 15200: Special Process Piping Systems)
 - d. Site drawings, showing extent of all utility systems (sewer, domestic water, storm, etc.), with preliminary sizing information.
 - e. Design calculations for mechanical and plumbing systems. For specific requirements, refer to the appropriate mechanical and plumbing sections of these Guidelines.
 - f. Repetitive areas may be presented as typical bays or floors.
4. Electrical:
 - a. Preliminary drawings, including plans and diagrams that indicate types of fixtures (fluorescent, compact fluorescent, etc.) and locations, primary and secondary switch gear, sizes and locations of power and lighting distribution panels. Special systems, i.e., public address systems, fire alarm, smoke

Stanford University-Facilities Design Guideline

detection, television, etc. can be indicated in the specifications and by notes on the drawings.

- b. Site drawings, indicating extent of exterior lighting and power distribution systems, including connections to campus sources, with preliminary sizing information. Refer also to Section 16520: Outdoor Lighting Systems.
 - c. Lighting: refer to Section 16500: Lighting.
 - d. Design calculations for electrical systems. For specific requirements, refer to the appropriate sections of these Guidelines.
 - e. Repetitive areas can be presented as typical bays or floors.
5. Fire protection: Preliminary drawing and specifications, including plans, riser diagrams, locations of sprinklers, fixtures, and major equipment, control diagrams, etc. Automatic Fire Sprinkler Systems, Section 13950 and Fire Alarm System Section 13850.
 6. Site Development drawings indicating all exterior appurtenances (for example: bike racks, pathways, parking, patios, benches, etc.) within the project envelope.
 7. Structural calculations appropriate to the design phase. Boring data or knowledgeable information of sub-surface conditions within the project envelope.
 8. Updated outline or program specifications, indicating special systems, fixed equipment requirements, and extent and type of all systems.
 9. Updated tabulation of Building Areas
 10. Statement of Probable Construction Costs
 11. Annotated Basis of Design
 12. MEP Quick Guide Comments Form
 13. Final Commissioning Strategy Plan (if applicable)
 14. List Any Deviations from the Facility Design Specifications

1.04 CONSTRUCTION DOCUMENTS SUBMISSIONS

A. General:

1. 50% Construction Documents review is intended to provide the University with an opportunity to check the progress of work during this phase and correct any errors or deficiencies before work has progressed to near completion. The University's Project Manager will work with the Designer or General Contractor to establish the schedule and scope of this review as appropriate for each project.
2. 100% Construction Documents review is intended to provide the University with a final comprehensive review of construction documents prior to issue for bidding or for determining a Guaranteed Maximum Price or Lump Sum Price. Consequently, review comments on the 100% CD submission shall be addressed and appropriate changes incorporated into the final construction documents before they are issued.

B. Minimum Submission Data:

1. Standard Contract Documents: Standard Contract Documents shall be assembled and bound at the front of the specifications; they will be developed and provided by the University's Procurement Office.
 - a. Cover sheet (include Stanford University project name and number, date)
 - b. Index
 - c. Invitation to Bid, to be dated and signed by Owner), including addenda
 - d. Instructions to Bidders,
 - e. Proposal Sheet(s)
 - f. Agreement
 - g. General Conditions

Stanford University-Facilities Design Guideline

- h. Special Conditions for Construction Contracts BY PROCUREMENT.
2. Complete drawings and specifications for all disciplines. For specific submittal requirements, refer to the appropriate sections of these Standards.
3. Tabulation of Areas
4. For budgetary and planning purposes, areas of site development should be summarized on the landscape drawings to include:
 - a. Lawn area (total square feet)
 - b. Ground cover area
 - c. Shrub area
 - d. Total perimeter of all lawn area
 - e. Total number of trees
 - f. Total number of shrubs
 - g. Parking lot area, excluding any planting islands
 - h. Total hard-surface, or patio areas
 - i. Total irrigated and non-irrigated landscaped area, excluding roads, buildings, and hard-surface areas
6. Finish Schedules: Designer shall provide one blank column on the finish schedule subtitled "Stanford Room Number". This column should be adjacent to the architect's room number or space name, and will be used by the University for identifying space allocated to various departments or personnel.

1.05 BID PERIOD SUBMISSIONS

- A. General: The Designer, in joint consultation with the University's Project Manager, Procurement, and the Construction Manager, shall select a list of bidders from the University's file of pre-qualified bidders, plus any other bidders the Architect may recommend. Upon joint agreement on the list of bidders, the University's Procurement Office will issue invitations to the approved bidders.
- B. Addenda: Addenda shall be placed at the front of the specifications, designed and numbered for incorporation into the appropriate drawings or specification sections.
- C. Post-Bid Submissions: The University's Project Manager shall submit a summary resulting from the bid opening, analyze same, and submit pertinent recommendations for review and approval.

1.06 CONSTRUCTION CONTRACT AWARD SUBMISSIONS

- A. General: The Designer shall prepare and furnish to Stanford eight (8) copies of the stamped drawings and nine (9) sets of bound contract documents, including specifications fully prepared for execution.

1.07 AS-BUILT RECORD DRAWINGS

- A. General:
 1. The agreement for professional services with the Architect or Engineer requires the submission of record drawings reflecting as-built conditions.
 2. The principal purpose of the as-built record drawings is to provide the University with a permanent record of actual construction to facilitate troubleshooting and to provide for the potential of future building alterations. We recognize that change orders and

Stanford University-Facilities Design Guideline

field directives result in actual construction that is somewhat at variance with the executable set of Construction Documents.

3. The Architect or Engineer, in his or her administration of the Construction Contract, is the logical focal point and repository for this as-built information. The Construction Contract requires the Contractor to record all changes to drawings and specifications as they occur, and to deliver these as-built drawings and specifications in both electronic and hard copy format to the Designer upon completion of the work. This information is the Designer's principal source of information in revising drawings and specifications for the record set. In addition, shop drawings, field notes, change orders, correspondence, and the Designer's own set of drawings will provide auxiliary information.
4. At the conclusion of construction, all changes shall be incorporated on the tracings by the Architect or Engineer and noted with a "goose egg" or similar designation showing it as "as-built", "change order number 4", or other appropriate notation. The specifications shall be annotated to show the actual selected products that are incorporated into the project, particularly where a choice of two or more products was permitted.
5. General Contractor shall include as part of the Project Dossier a set of the final structural, mechanical, and electrical calculations that were prepared during the design phase. Submitted material should be clearly marked "as-built" and dated.
6. See Maps and Records <http://maps.stanford.edu/delivering> for information on current CAD standards).

1.08 OPERATING AND MAINTENANCE MANUALS

A. General:

1. This Article contains the general requirements for operating and maintenance manuals to be submitted, reviewed, and approved well in advance of Owner occupancy. The manuals and other supporting material listed herein must contain accurate as-built data, drawings, charts, etc. on each operating system to permit Stanford maintenance personnel to take over maintenance with written instructions sufficient to insure operations and maintenance in accordance with manufacturers' specifications. It is the responsibility of the Architect/Engineer to incorporate the applicable provisions of these Standards into the Project Specifications or other contract documents, and to ensure that the Contractor complies with the Specifications, including the incorporation of these changes in design and specifications during construction into the as-built documents.
2. Description of Systems: In accordance with the sample Project Dossier, the General Contractor shall include in the Project Dossier descriptions of the design intent of the building systems (HVAC, Electrical, and others as applicable) and the principles of their operation in a manner to permit prompt initial understanding of the systems by qualified University maintenance personnel. These descriptions shall include flowcharts, riser diagrams, zone control layouts, and other visual aids showing the components and their relationship to the entire system.
3. Copies in Electronic format (pdf) shall be part of the submitted package.

B. Manuals of Systems Components to be specified by Designer: The General Contractor shall specify as applicable to the particular designed system the following information:

1. Manufacturers' printed installation and operating instructions. This shall be the technical specifications and instructions, not "sales" brochures and promotional

Stanford University-Facilities Design Guideline

- material. Instructions shall include all modes of operation in sufficient detail to be readily understood by Stanford maintenance personnel.
2. Complete identification in the manuals of the actual equipment installed as described in the manufacturers' instructions, including dimensional drawings, model, type, size, capacity, performance parameters such as curves, efficiencies, power requirements, operating ranges, etc. NOTE: In cases of multiple installation of identical equipment, only one manual submitted for the identical equipment is necessary, but serial numbers of the several pieces of equipment shall be listed.
 3. Names, addresses, telephone numbers, "person to contact" (if known) of subcontractors, their suppliers, manufacturers' representatives, available service facilities and normal channels of supply.
 4. Detailed parts list showing manufacturers' parts numbers and such other identification as necessary to facilitate procurement of spare or renewal parts and Owner-Manufacturer communications.
 5. Manufacturers' maintenance instructions shall include schedules showing proper time intervals for lubrication, adjustment, and calibration or checking. Contractor shall consolidate manufacturers' schedules with a single master schedule of required maintenance. This requirement is for the Contractor's as well as the Owner's protection to insure proper early maintenance during the warranty period.
- C. Submission of Operating and Maintenance Manuals: Contractor shall submit to Project Manager no later than the seventy-five percent (75%) completion date of the HVAC systems as shown on Payment Requests, four sets of manuals (or if deemed prudent, a draft set of manuals) for review. The University's Project Manager will circulate the document to the appropriate University personnel for their comments and recommendations, and upon receipt shall return them to the Designer, who will then secure the required corrections and transmit three (3) completed sets to the University's Project Manager before a Certificate of Substantial Completion is issued.

END OF SECTION

SECTION 01770

CLOSEOUT AND TURNOVER PROCEDURES

PART 1 GENERAL

1.1 RELATED WORK

A. 01330 Submittal Procedures

1.2 REFERENCES

1.3 ABBREVIATIONS

A. Buildings and Grounds Maintenance (BGM)

B. Sustainability and Energy Management (SEM)

C. Land, Buildings and Real Estate (LBRE)

1.4 OVERVIEW: PROJECT CLOSEOUT AND TURNOVER PROCEDURES

- A. The General Conditions of the Construction Contract contain instructions and requirements of the Contractor, the Architect and the University for acceptance of the project. Stanford also has internal procedures for turning over the project to the appropriate maintenance department. (A masterlist of responsible maintenance departments can be found on the FDG website under the “responsible organization” column associated with each FDG section). The Architect is responsible for including in the Specifications the obligations of the Contractor for an orderly acceptance and turnover. Included in such obligations are punch lists, "as-built" plans and specifications including CAD drawings, operating and maintenance manuals, and training of Stanford’s maintenance personnel. The Project Manager is the point of contact with these departments.
- B. This document is intended to be used during the formulation process to identify costs that may or may not be associated with this procedure, and to identify to the contractor and subs exactly what is expected at turnover by LBRE (BGM/SEM).
- C. This procedure is to be reviewed again during substantial completion by the User, PM and a BGM and SEM Representative to ensure that reporting procedures have been followed and this document has been adhered to with all pertinent documentation recorded and submitted.

PART 2 PRODUCTS

2.1 Deliverables:

See PDP Manual and Checklists, and FDG Section 01330.

A. Formal Notice of Maintenance Assumption by LBRE:BGM/SEM: As mentioned above, a formal letter turning over maintenance to LBRE:BGM/SEM will be delivered at substantial completion. Copy of the form letter shall be sent to the Owner representative and LBRE:BGM/SEM Department representative.

B. Turnover Documentation at Substantial Completion Phase: Once the Project Manager receives and reviews the turnover documentation, the project manager will transfer documents to Stanford's Shared Network S:drive for Zones, SEM and Maps and Records to review. Contractor shall submit the following turnover documentation electronically to the Project Manager by method of File Transfer Protocol (FTP) or by CDs:

1. Turnover Letter (includes Warranty Start Date and System Deliverable)
2. Copy of current Punch List (showing exceptions if Contractor is to continue maintenance of specific systems).
3. List of PM/GC and subcontractors for critical equipment, with persons to contact, addresses, and phone numbers for 24/7 contact for warranty items
4. Operating and Maintenance Manuals for critical equipment
5. Project Specific Turnover checklist (completed by PM, Zone Manager and Utility Rep)
6. Completed Balance and Testing Reports
 - o Air Balance Reports
 - o Water Balance Reports
7. Equipment training attendance sheet with training agenda
8. Alarm Points and Set Points
9. Copy of the County Certificate of Occupancy (includes any conditions of occupancy)

C. Final Documentation at Closeout Phase (approximately 3 months from Substantial Completion): Once the Project Manager receives and reviews the documentation, the Project Manager will transfer documents to Stanford's Shared Network S:drive for Zones

and SEM to review. Once reviewed by Zones and SEM, the Zone Manager will submit to Stanford's Maps and Records Department (<http://maps/delivering>):

1. Notice of Completion – Closeout Letter (transmittal sheet listing all Final Deliverables)
2. Completed Punch List of all items
3. Final Warranty Letters
4. Final As-Built Drawings (electronic: dwg and pdf files).
5. Operating and Maintenance Manuals for all equipment
6. Relevant Reports or Tests
 - a) Air/Water Balance and Testing, Vibration Testing, Acoustic Report, DI Water System Testing, etc.
 - b) Electrical Short-circuit Study and Arc Flash Hazard Analysis Calculations and Report
 - c) Annotated Basis of Design (if original Basis of Design has changed)
 - d) Annotated Project Specifications (if original Project Specifications has changed)
 - e) Commissioning Inspection Reports (including functional performance test and As-Built Sequence of Operations)
7. Completed Project Specific Turnover checklist (completed by PM, Zone Manager and Utility Rep)
8. Furniture Specifications (to be given to end user)
9. Tools and Equipment Fit Up Matrix (if available/applicable)
10. As-Built Energy & Water Model (if available/applicable)
11. Final Submittals (only critical and digital submittals)
12. 3D Model (if available/applicable)
13. Warranty Issues

14. Spare parts and material (Attic Stock)

15. Alarm Points and Set Points (Final)

16. Signed Off Permits

PART 3 EXECUTION

3.1 Training of Maintenance Personnel:

A. Periodic Walk-Throughs during Construction: At various stages of construction, Maintenance personnel shall, as deemed necessary (and scheduled by BGM and SEM), meet PM/GC and appropriate subcontractor foremen at jobsite to observe portions of the project concerning their trades, and to familiarize themselves with construction details before they are closed in. A copy of each monthly Major Project Construction Report will be forwarded to Maps and Records (for the project file and for communication to appropriate LBRE (BGM/SEM) departments to keep them informed of the progress of construction for each project. During periodic walk-throughs, (ideally during the construction phase of the project), the BGM/SEM Representative will try to identify any areas that might be difficult to reach, or access after portions of the building are closed in, and other possible maintenance problems. A written Site Observation list for corrections will be forwarded to the PM. These items are to be incorporated into the Project's punch-list and addressed accordingly by the PM/GC through coordination by the BGM/SEM Rep.

B. Acceptance-Walk-Through: After the Architect's inspection and walk-through for purposes of issuing a Certificate of Substantial Completion, an acceptance walk-through will be scheduled by the PM with LBRE:BGM/SEM.

- In the event that a temporary or partial occupancy permit is issued by the county, prior to substantial completion, such documentation shall be attached to the substantial completion form for review by all parties (i.e.; Architect, PM/GC, LBRE:BGM/SEM personnel including; Building Maintenance, Utilities, Maps & Records, Zones, Contract Services and Grounds).

C. To aid LBRE:BGM/SEM in the acceptance period, the Contract Specifications should provide for negotiated amount of training. This time would be utilized for each Foreman of the electrical, mechanical, and plumbing subcontractors to be made available to LBRE:BGM/SEM for further instruction (if necessary), so that subjects not fully covered in the formal acceptance walk-through may be discussed further.

D. The date of the Certificate of Substantial Completion establishes the start of the warranty period, with exceptions noted and estimated completion dates for exceptions,

which is for one year unless otherwise stated in the Contract Documents. If any punch list items not corrected are noted by the occupant or any LBRE:BGM/SEM Staff during this lien period, the BGM Rep. will promptly inform the Project Manager. However, it is the responsibility of the Project Manager to insure timely completion of Punch List corrections.

- Quarterly meetings are to be scheduled and attended by the PM/GC, Building Manager and LBRE: BGM/SEM Rep. to discuss any on-going warranty issues (if applicable)

3.2 DEFICIENCIES

A. Design Deficiency Problems: In some cases, LBRE:BGM/SEM will discover that the Building Occupant complaint relates neither to maintenance nor warranty deficiencies. LBRE:BGM/SEM will then contact the PM, describe the problem, and recommend any improvements deemed necessary. If the problem is indeed a design or construction defect or error, the PM will discuss the matter with the Building Occupant, the Architect/Engineer, and LBRE:BGM/SEM to determine a solution, if possible. Corrective work then will be performed by contract, negotiated or bid by the PM.

B. Equipment Failure under Warranty: All new equipment shall be assumed to be in prime operating condition upon turnover. LBRE:BGM/SEM will perform routine maintenance in accordance with the operating manuals, with the first scheduled maintenance measured from the date of turnover. The Project must provide BGM with all applicable O&M documents, warranty documents and contractor/vendor contact information at turnover. All equipment failures during the first year of warranty are the responsibility of Zone Management to schedule repair by the responsible sub-contractor.

END OF SECTION