

CELEBRATING YOUR WEDDING
AT
THE COLLEGIATE CHURCH OF
CHRIST THE TEACHER

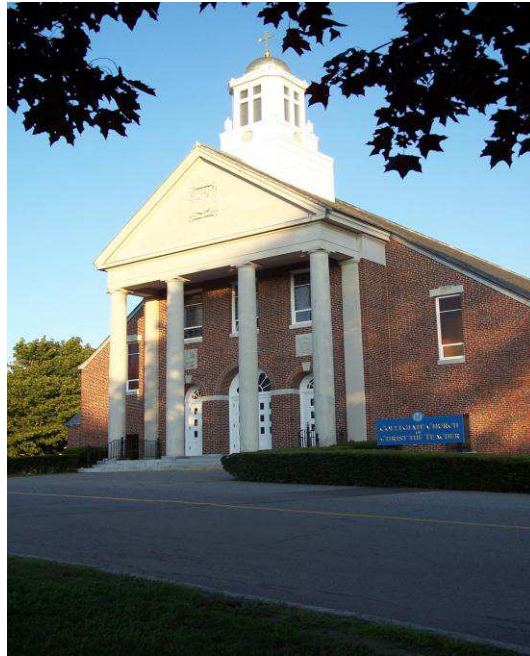

MERRIMACK COLLEGE
NORTH ANDOVER, MASSACHUSETTS

**THE GRACE J. PALMISANO
CENTER FOR CAMPUS MINISTRY**

MERRIMACK COLLEGE
315 TURNPIKE STREET
NORTH ANDOVER, MA 01845

PHONE: 978-837-5450
FAX: 978-837-5004

Revised: April 2012

Congratulations and Blessings on your Engagement!



Dear Engaged Couple,

On behalf of the Merrimack College Community, we in the Grace J. Palmisano Center for Campus Ministry congratulate you on your engagement and pray that God will continue to bless you for years to come. Your decision to enter into the relationship of married life is a sign of love, hope, and strength for the entire Church community.

Since you have arranged to celebrate your wedding at the Collegiate Church of Christ the Teacher, we would like to outline for you the requirements for the celebration. This booklet and accompanying forms and letters have been designed to assist you in your preparation and inform you of Church and Civil requirements for marriage in the Roman Catholic Church at Merrimack College. Please take time to read the following pages thoroughly. We ask for your full attention and cooperation to the policies and procedures so that all members of the community may be served in a respectful manner. Once your reservation has been made, you have three weeks to submit the wedding agreement and fee* to the Center for Campus Ministry. If you have not done so, please call to schedule an initial meeting with the wedding coordinator.

If at any time you have questions or need additional assistance in planning your wedding, please feel free to contact us.

Yours in Christ and Augustine,

The Campus Ministry Team
Merrimack College
978-837-5450

**Please see Page 8, Number 1.*

TABLE OF CONTENTS

I.	Marriage Preparation	4
II.	Wedding Day and Rehearsal Reservation	4
III.	Required Documents	5
IV.	Additional Sacramental Requirements	6
V.	The Preparation Workshop	7
VI.	General Information	8 - 9
VII.	Environmental Guidelines	10
VIII.	Guidelines for the Photographers and Videographers	11
IX.	Wedding Church Layout Options	12
X.	Wedding Plan Checklist	13

MARRIAGE PREPARATION

Engagement is a special time in marriage formation and preparation. It is a time of excitement in your life as a couple as you get closer to your wedding day. It is a time to enjoy, to talk, and to share your deepest and most personal values. It is a time to reflect and to pray together.

Because Merrimack College is not a parish, weddings are not usually permitted to be celebrated at the college. The Archdiocese of Boston, however, has given special permission for weddings of an alumnus(a) or a student of Merrimack College to be celebrated on campus.

All couples are required to attend a Pre-Cana Program or an Engaged Encounter Weekend *no later than six months prior* to the celebration of the Sacrament of Marriage. These days or weekends are designed to assist the couple in the marriage preparation process and address issues central to a successful Christian Marriage.

A complete list of Pre-Cana and Natural Family Planning workshops is available through:

Family Life Office of the Archdiocese of Boston

Archdiocesan Pastoral Center

66 Brooks Drive

Braintree, MA 02184-3829

617-254-0100

www.rcab.org

WEDDING DAY AND REHEARSAL RESERVATION

The church must be reserved for the weddings and rehearsals by making arrangements with the Administrative Assistant in the Campus Ministry Office at 978-837-5450.

No weddings are celebrated in the Collegiate Church on:

Christmas Eve, Christmas Day, New Year's Eve, New Year's Day, or Easter weekend.

In addition, no weddings take place on:

Homecoming weekend, Reunion weekend, Move-in weekend (which is usually Labor Day weekend), and Commencement weekend.

At times, weddings may not be permitted on other holiday weekends. Because of special needs of the college, there may be other weekends, especially in April and May, in which weddings may not take place.

REQUIRED DOCUMENTS

1. **WEDDING AGREEMENT:** In order to confirm your wedding date, the blue Wedding Agreement form and a \$600.00 fee* is to be returned to the Center for Campus Ministry within three weeks of the date you reserve the church. This fee includes administrative work, the sacristan, and the use of the Church for both the rehearsal and the wedding, the initial meeting with the wedding coordinator, basic liturgical supplies, and the Preparation Workshop. It does not include the priest/deacon, musicians or any other expenses associated with the wedding.
2. **LETTERS OF PERMISSION:** According to church law, the Sacrament of Marriage is to be celebrated in the parish of either the bride or groom. Permission is needed for the sacrament to be celebrated elsewhere. Since the Collegiate Church is not a parish, either the bride or groom needs permission from the pastor of the parish in which she or he is currently registered.
3. **BAPTISMAL CERTIFICATE:** Both Catholic partners must obtain a RECENTLY ISSUED baptismal certificate from the place of Baptism within six (6) months before the marriage. This is NOT the original certificate or a copy of that certificate, but a standard form which the baptizing parish fills out. A “Long Form” is required which will indicate any other sacramental notations on the back. If one party is not Roman Catholic, a Baptismal certificate is still required. If one party is not baptized, then the necessary dispensations are required.
4. **PRE-NUPTIAL INVESTIGATION (PNI):** Couples will complete the form of the Archdiocese of Boston with the consulting priest.
5. **MARRIAGE LICENSE:** A Marriage License for the Commonwealth of Massachusetts is to be obtained within 60 days of the wedding date and brought to the rehearsal. Contact any courthouse in the Commonwealth for more information regarding civil requirements.
6. **LITURGY & MUSIC PLAN:** This form is designed to aid the efficiency of your wedding rehearsal as well as any preparation on Campus Ministry’s end. It is to be brought to the rehearsal and given to the Wedding Sacristan.

N.B. All paperwork, unless otherwise noted, is due in the Center for Campus Ministry at least one month prior to the wedding. The wedding that does not complete all requirements will not take place.

**Please see Page 8, Number 1.*

ADDITIONAL SACRAMENTAL REQUIREMENTS

Church Witness / Presider: Couples marrying at the Collegiate Church of Christ the Teacher are responsible for asking a Roman Catholic Priest or Deacon to officiate at their wedding. In choosing a presider, you may wish to ask your parish priest, deacon, or a priest or deacon who is a family member or friend. You should secure a priest or deacon immediately and also be aware that the availability of Augustinian Friars on campus is limited. Upon deciding upon a priest or deacon, contact Campus Ministry with his name, address and phone number so we may send him the proper delegation and the information he will need. All presiders are asked to abide by the regulations for weddings at the Collegiate Church of Christ the Teacher. Guidelines will be forwarded to him. Should he have any additional questions, he may contact the Campus Ministry Office.

After your inquiry session with the wedding coordinator, it is good to meet with the presiding priest/deacon to focus your intentions, collect all necessary documents and paperwork, plan the liturgy and otherwise prepare for the Sacrament of Marriage. That responsibility is yours. All necessary paperwork is to be completed and returned to the Center for Campus Ministry one month prior to the wedding date. That paperwork includes: *The Archdiocese of Boston Preliminary Interrogatory Form, recently issued Baptismal Certificates for Bride and Groom, Pre-Cana certificate, all necessary dispensations and/or declarations of nullity and all ceremony forms included in the packet.*

It is customary to offer your presider (i.e., priest or deacon who officiates) a stipend for his time and work on your behalf. This stipend, which is up to your discretion, is not included in your wedding fee.

Dispensations and Declarations of Nullity: *This only applies if one or both parties has been previously married or if one party is from another religious tradition.* The priest or deacon officiating at your wedding is responsible for acquiring any and all dispensations necessary for the marriage. If an annulment is necessary, the date of the wedding cannot be reserved until the annulment is granted. No marriage may take place at the Collegiate Church unless both parties are free of prior bonds (i.e., previous marriage) and impediments, with necessary dispensations (e.g., if one party is from a non-Christian tradition) and permission (e.g., if one party is from a Christian tradition outside of the Roman Catholic Church).

THE PREPARATION WORKSHOP

The Center for Campus Ministry offers a Preparation Workshop. This workshop covers many aspects for the liturgical planning of the wedding and in particular the music. This workshop is provided several times a year. You will receive an invitation with the appropriate information. During the workshop, you will be given guidance about scripture readings and other liturgical principles. You will also hear examples of appropriate music performed live, have the chance to meet an organist, soloist and instrumentalist, and ask questions. Since your wedding is a sacramental event, only sacred music is permitted.

For both the Rite of Marriage within and outside the context of Eucharist, the minimum music requirement is an organist/pianist and preferably a cantor. You may choose from musicians on the list that follows, all of whom are fluent in the rites of the Roman Catholic Church. Any musician not on this list must register with the wedding coordinator. This is to ensure that your musician of choice understands the role of music in liturgy and is capable of leading song in a proper liturgical setting.

ORGANISTS:	Hugh Hinton	508-685-9496	hintonh@merrimack.edu
	Rob Humphreville	617-864-0800	r.hump@verizon.net
	Karen Leonard	978-256-8404	
	Paula Lowell	978-475-0050	(St. Augustine Church, Andover, MA)
	Fred MacArthur	978-609-4302	fredorganist@yahoo.com
	John Middleton	978-683-7777	
	Charlie Connor	617-484-1770	
PIANISTS:	Phil Naroian	978-815-8076	
	John A. Middleton	978-683-7777	
VIOLINISTS:	Diane Lafond	978-687-7098	
	Andre Passanisi	603-887-2949	
	Amos Lawrence	617-505-6412	amoslawrence1@gmail.com
	Elizabeth Jones	978-518-2201	joneseb@merrimack.edu
SOLOISTS:	Dolores M. Goyette	978-621-2872	drgoyette@gmail.com
	Cynthia Cookson	978-470-1389	
	Lori Charette-McLaughlin	603-432-8656	
	Patricia Natti	978-281-4134	pnatti@adelphia.net
TRUMPETERS:	Steve Goddu	603-890-2406	
	Vinnie Monaco	978-475-6095	
GUITARISTS:	Tony Zannini	603-421-2985	
BRASS CHOIR:	Peter Sexauer Festival Brass	978-256-4844	
STRING QUARTET:	M.S. Music Associates / Margaret Strange:	617-645-5938	
CANTOR:	It is good liturgical principle to have a cantor, one who leads the congregation in singing. Consequently, it is encouraged that the ministry of the cantor be utilized at the wedding. Our Wedding Coordinator is available for hire to serve as cantor for your wedding.		

GENERAL INFORMATION

1. ***FEE:** The fee of \$600.00 is due within three weeks of reserving the church. This fee includes the administrative work, the sacristan, and the use of the Church for both the rehearsal and the wedding, the initial meeting with the wedding coordinator, basic liturgical supplies, and the Preparation Workshop. It does not include the priest/deacon, musicians, or any other expenses associated with the wedding. If, for some reason, you choose to cancel your wedding reservation ***within the first thirty days of your contract***, you will receive your reservation fee back **in full**; afterwards, half of the fee will be refunded. All paperwork, unless otherwise noted, is due in Campus Ministry at least one month prior to the wedding. *The wedding that does not complete all requirements will not take place.*
2. **PROCESSION:** There are a variety of options to choose for your wedding. You may be as traditional as possible (e.g., groom in the sanctuary; bride escorted by her father). It is also nice to have the groom process in with his parents, and the bride with hers. You may even have a liturgical procession (i.e., Cross-bearer, Readers and Priest, followed by wedding party).
3. **REHEARSAL:** Please be prompt for your rehearsal time. All those who are involved in the wedding liturgy are expected to be present. This includes all members of the wedding party, the readers, as well as the cross bearer if you choose a liturgical procession. The cross bearer should come from your family or friends. Musicians do not attend rehearsals. A wedding Sacristan will be available to you during your rehearsal. A request to change rehearsal time must be submitted *in writing* to the Office of Campus Ministry.
4. **WEDDING PROMPTNESS:** It is recommended that the Groom and Groomsmen arrive 30 minutes before the wedding time, and the Bride and Bridesmaids arrive at least 20 minutes before the wedding time.
5. **INVITATIONS:** Since the proper name of the campus church is "The Collegiate Church of Christ the Teacher at Merrimack College," the wedding invitation should read:

**The Collegiate Church of Christ the Teacher
Merrimack College
North Andover, Massachusetts**
6. **WEDDING SACRISTAN:** In order for your liturgy to run smoothly, Campus Ministry provides a wedding sacristan for both the rehearsal and the liturgy. The sacristan will assist guest presiders, bride, groom, photographers/videographers, ushers, bride's attendants, and guests.
7. **ALTAR SERVERS:** Most weddings do not utilize altar servers. If you would like servers, you will need to provide them from among your family or friends. Please note that if the altar servers are not wearing a shirt and tie, they need to provide their own liturgical robes. Be sure to inform the sacristan if you choose to have altar servers.

(GENERAL INFORMATION, continued)

8. **RECORDING THE MARRAGE:** Because Merrimack College is **not a parish**, we cannot record the marriages at Merrimack. Marriages celebrated at Merrimack College are recorded at St. Michael Parish in North Andover, MA as Merrimack is within the parish boundaries of St. Michael parish.

9. **FACILITIES:**

- ◆ We regret that the Collegiate Church of Christ the Teacher is **NOT HANDICAPPED ACCESSIBLE**.
- ◆ The Collegiate Church of Christ the Teacher is **NOT AIR-CONDITIONED**.
- ◆ The main aisle is ninety (90) feet long and seven (7) feet wide. Side aisles are five (5) feet wide.
- ◆ There are 31 pews on each side of the main aisle. The Church holds 600 people.
- ◆ The loft is equipped with a Prestige G501-D Electric, 2 manual rocker tab organ with MIDI capability.
- ◆ The transept in front of St. Joseph the Worker includes a grand piano and timpani.
- ◆ Restrooms are located on the lower floors and are accessible from the side doors of the church.

ENVIRONMENTAL GUIDELINES

1. The liturgical environment is designed to reflect the season in which we are celebrating. There will always be greenery appropriate to the Liturgical Seasons of Advent, Lent, Easter and Ordinary Time. You may bring in up to two additional floral pieces except during Advent and Lent to augment the existing floral arrangements, but you may not move or in any way disturb what is already there. The wedding coordinator or sacristan can help you choose appropriate arrangements.
 - ◆ **Advent:** Simple greenery and advent candles (beginning four Sundays prior to Christmas) will be provided. No additional flowers.
 - ◆ **Lent:** Very stark/simple arrangements (Lent begins on Ash Wednesday and continues for 40 days until the Triduum leading into the Easter Season). No additional flowers.
 - ◆ **Easter Season:** Festive Spring arrangements from Easter Sunday through Pentecost (about 7 weeks).
 - ◆ **Ordinary Time:** The remainder of the year, simple floral arrangements according to the month/season.
2. Pew decorations must be tied or clipped. We have found that bows/flowers are most secure when TIED to the pew with ribbon. NO TAPE. If tape is used, a cleaning fee of \$50.00 will be charged to the florist.
3. The use of the "Unity Candle", which is not part of the Roman Catholic Rite of Marriage, can be discussed with the presiding priest or deacon.
4. Since the Collegiate Church is carpeted and because of safety reasons, no aisle runners are permitted.
5. Receiving lines, rice, birdseed, bubbles, confetti, flower petals, streamers, live animals (other than Guide Dogs), et cetera are **NOT permitted IN** The Collegiate Church of Christ the Teacher.
6. It is discouraged to have children less than six years of age in the wedding party.

GUIDELINES FOR THE PHOTOGRAPHERS AND VIDEOGRAPHERS

The Photographer/videographer must check in with the sacristan the day of the wedding to ensure he or she knows his or her role in the ceremony. Photographers are asked to comply with the policy outlined below. Please give the green copy of this form (2) found in your wedding packet to both the photographer and videographer.

Photographers MAY:

1. Take photographs of the guest as they arrive.
2. Take photographs of the ushers/groom prior to the ceremony provided guests are not left unattended.
3. Take photographs of the procession, reading of scripture, wedding ceremony, and preparation of gifts, communion procession and recessional.
4. Take photographs in the Church after the wedding if arrangements have been made ahead of time for the availability of the space.

Photographers MAY NOT:

1. Take photographs during the Eucharistic Prayer.
2. Cause the ceremony to start late for "limo" pictures.
3. Interrupt the flow of the procession in any way, shape or form.
4. Enter the sanctuary area for any reason.
5. Change the church environment for any reason.
6. Block the view of guests.

Videographers:

- ◆ Remote or unattended photographic equipment is **NOT** permitted in the choir loft.

WEDDING CHURCH LAYOUT OPTIONS

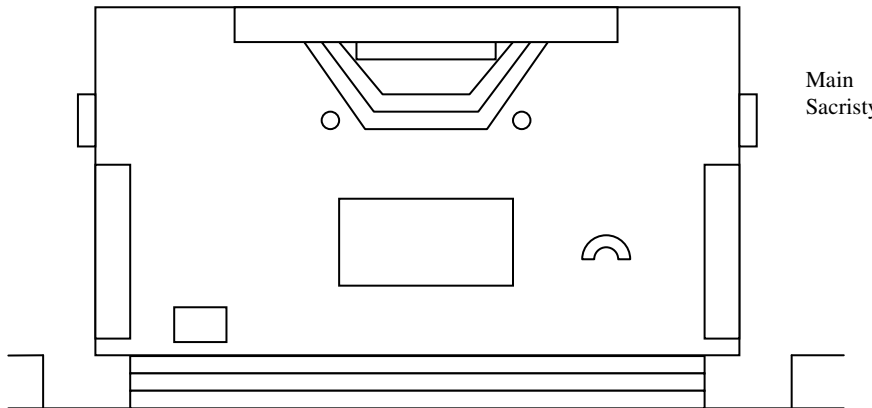

SET UP **OPTION 1**

Bride and Groom only
(facing congregation)

Best Man & Maid of Honor
(aisle seat first pew 😊)

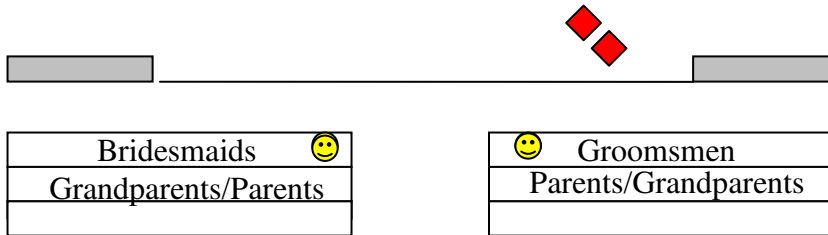

SET UP **OPTION 2**

Bride & Groom
(facing altar)

Best Man & Maid of Honor
(aisle seat first pew 😊)

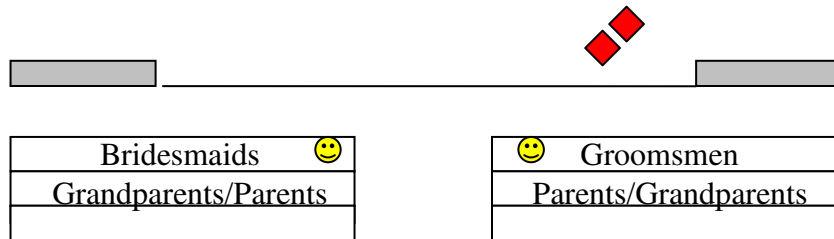
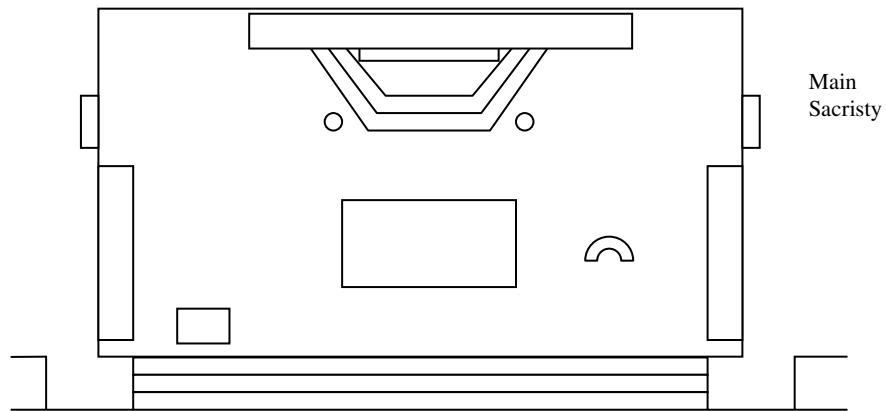

WEDDING PLAN CHECKLIST

REQUIRED

- One person must be a graduate OR a student of Merrimack College.
- The bride or groom OR both should be a practicing Catholic.

TIMELINE

6 – 12 MONTHS

- Reservations must be made at least 6 MONTHS in advance.
 - Call the Campus Ministry Office (978-837-5450) to inquire about the availability of a specific date and couple's information will be forwarded to the wedding coordinator.
- Wedding coordinator will set up a meeting to go over important preliminary information regarding their wedding ceremony preparation.
 - The Wedding Agreement will be filled out and signed by the couple at that meeting. [blue form, signed and returned with fee]
- Wedding fee* of \$600 is due within three (3) weeks of reserving your wedding date. The date is not confirmed until the fee has been paid.
- Contact the priest or deacon with guidelines and timelines for necessary documentation:
 - Sacramental Preparation [with presiding priest or deacon]
 - Pre-Nuptial Interview [green form completed with presiding priest/deacon]
 - Declaration of Nullity [if prior bond existed]
 - Recently issued Baptismal Certificates [with all sacramental notations]
 - Letter of Permission [from current Pastor]
- When applicable, the Administrative Assistant sends a delegation letter to the visiting priest or deacon which serves as a delegation for him to preside at The Collegiate Church for the couple's wedding.
- Pre-Cana/Engaged Encounter [including certificate]
- The Preparation Workshop

**Please see Page 8, Number 1.*

ONE MONTH

- Invitations
- Liturgy & Music Plan [yellow form, due one month before wedding]
- Photographer/Videographer [green form]

REHEARSAL

- Marriage License [bring to rehearsal]
- All paperwork must be submitted to the Campus Ministry Office from the presider in order to send the notification of marriage (Archdiocesan letter) to the parishes where the bride and/or groom (if Catholic) were baptized.

The Wedding is recorded at St. Michael Parish, North Andover, MA as previously stated on Page 9, Number 8.



MERRIMACK COLLEGE
315 TURNPIKE STREET • NORTH ANDOVER, MASSACHUSETTS 01845