

Installation
Operation
and
Maintenance
Instructions

Refrigerated Drawer Models

60RDE

80RDE

60RDE



TABLE OF CONTENTS

Unpacking your refrigerated drawer unit.....	2
Removing the packaging.....	2
Warranty Registration.....	2
Installing your refrigerated drawer unit.....	3
Selecting the location.....	3
Outdoor Installation.....	3
Cabinet Clearances.....	3
Leveling legs.....	3
Grounding method.....	3
Electrical Requirements.....	3
Installing the anti tip device.....	4
Dimensions Indoor Model 60RDE.....	5
Recommended Rough in Opening Dimensions	
Indoor Model 60RDE.....	5
Dimensions Indoor Model 60RDE Overlay Door..	6
Recommended Rough in Opening Dimensions	
Indoor Model 60RDE Overlay Door.....	6
Dimensions Outdoor Model 60RDE.....	7
Recommended Rough in Opening Dimensions	
Outdoor Model 60RDE.....	7
Dimensions Indoor Model 80RDE.....	8
Recommended Rough in Opening Dimensions	
Indoor Model 80RDE.....	8
Dimensions Indoor Model 80RDE Overlay Door.....	9
Recommended Rough in Opening Dimensions	
Indoor Model 80RDE Overlay Door.....	9
Full Overlay Panel Installation Instructions.....	10
Using Your Refrigerated Drawers.....	12
Starting Your Appliance.....	12
Set Your Temperature Mode.....	12
Set the Desired Temperature.....	12
Load Your Appliance.....	12
Interior Light.....	12
Defrost Cycle.....	12
Sabbath Mode.....	12
Warning Alarms.....	13
Sentry System™ Quick Reference.....	14
Care and Cleaning.....	16
E-Z Store Storage System (Optional).....	16
Drawer Dividers (Optional).....	16
Troubleshooting Guide.....	17
Obtaining Service.....	17
Household Product Warranty.....	18

Important Safety Instructions

Warnings and safety instructions appearing in this guide are not meant to cover all possible conditions and situations that may occur. Common sense, caution, and care must be exercised when installing, maintaining, or operating this appliance.

Recognize Safety Symbols, Words, and Labels.

CAUTION

CAUTION-Hazards or unsafe practices which could result in personal injury or property or product damage.

WARNING

WARNING-Hazards or unsafe practices which could result in personal injury.

NOTE

NOTE-Important information to make a problem free installation.

UNPACKING YOUR REFRIGERATED DRAWERS

Remove Packaging

Your refrigerated drawers have been packed for shipment with all parts that could be damaged by movement securely fastened. Cut the banding material at the bottom of the carton, unfold the cartoning at the bottom and remove the carton from the appliance. Remove the plastic bag, styrofoam corner posts and any tape holding the drawers closed and internal components in place. The owners manual is shipped inside the drawer in a plastic bag along with the warranty registration card.

Important

Keep your carton packaging until your refrigerated drawers have been thoroughly inspected and found to be in good condition. If there is damage, the packaging will be needed as proof of damage in transit. Afterwards please dispose of all items responsibly in particular the plastic bags which can be a suffocation hazard.

Note to Customer

This merchandise was carefully packed and thoroughly inspected before leaving our plant. Responsibility for its safe delivery was assumed by the retailer upon acceptance of the shipment. Claims for loss or damage sustained in transit must be made to the retailer.

DO NOT RETURN DAMAGED MERCHANDISE TO THE MANUFACTURER - FILE THE CLAIM WITH THE RETAILER.

If the unit was shipped or has been laying on its back for any period of time allow the refrigerator to sit upright for a period of at least 24 hours before plugging in. This will assure oil returns to the compressor. Plugging the refrigerator in immediately may cause damage to internal parts.

Warranty Registration

It is important you send in your warranty registration card immediately after taking delivery of your refrigerated drawers or you can register online at www.marvelrefrigeration.com.

The following information will be required when registering your unit.

Model Number
Serial Number
Date of Purchase
Dealers name and address

The model number and serial number can be found on the serial plate which is located on the bottom of the cabinet liner in the left front corner. Open the bottom drawer to full extension to view it.

CAUTION

Help Prevent Tragedies

Child entrapment and suffocation are not problems of the past. Junked or abandoned refrigerators are still dangerous - even if they sit out for "just a few days".

If you are getting rid of your old refrigerator, please follow the instructions below to help prevent accidents.

Before you throw away your old refrigerator or freezer:

- Take off the doors or remove the drawers.
- Leave the shelves in place so children may not easily climb inside.

INSTALLING YOUR REFRIGERATED DRAWERS

Select Location

The proper location will ensure peak performance of your appliance. We recommend a location where the unit will be out of direct sunlight and away from heat sources. To assure your product performs to specifications the recommended installation location temperature range is from 55 to 100°F (13 to 38°C).

⚠ CAUTION

Outdoor Installation

Only the 6ORDE model is suitable for outdoor installations. A ground fault circuit interrupter electrical receptacle is to be used to supply electrical power to the refrigerator for outdoor applications. Contact an electrician if you need to install one to supply electrical power to your outdoor refrigerator. Do not install in an environment where the unit will be exposed to direct sun exposure as this may result in unsatisfactory performance.

Cabinet Clearance

Ventilation is required from the bottom front section of the unit. Keep this area open and clear of any obstructions. Adjacent cabinets and countertop can be installed around the unit as long as the grille and drawer access remain unobstructed.

⚠ CAUTION

Front Grille

Do not obstruct the front grille. The openings within the front grille provide air to flow into and exit from the refrigerator condenser. For this reason it is important this area to not be obstructed and be kept clean. Marvel does not recommend the use of custom made grilles as air flow may be restricted because of inadequate openings. (See Figure 1).

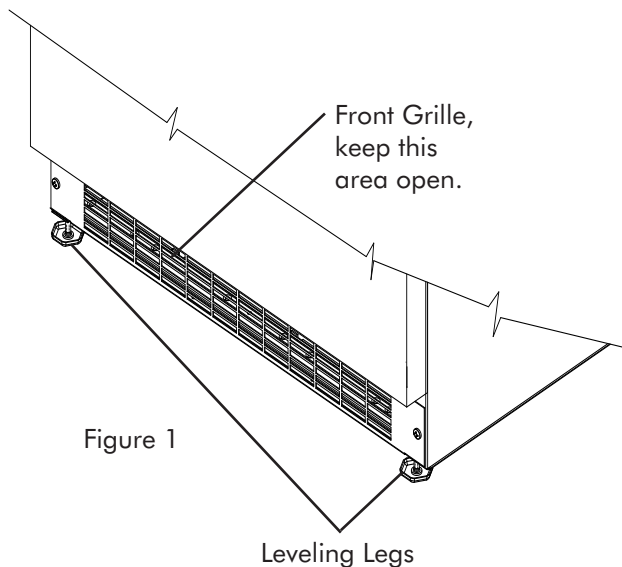

Leveling Legs

Adjustable legs at the front and rear corners of the unit should be set so the unit is firmly positioned on the floor and level from side to side and front to back. Turn leveling legs clockwise to raise unit, counterclockwise to lower it. (See Figure 1).

⚠ CAUTION

- Do not splash or spray water from a hose on the refrigerator! Doing so may cause an electrical shock, which may result in severe injury or death.
- This unit should not, under any circumstances, be ungrounded.

Grounding Method

This product is factory equipped with a power supply cord that has a three-pronged, grounded plug. It must be plugged into a mating grounding type receptacle in accordance with the National Electrical Code and applicable local codes and ordinances (see Figure 2). If the circuit does not have a grounding type receptacle, it is the responsibility and obligation of the customer to exchange the existing receptacle in accordance with the National Electrical Code and applicable local codes and ordinances. The third ground prong should not, under any circumstances, be cut or removed.

Electrical Connection

115 volts, 3.3 amps running max. 15 amp dedicated circuit required. 3 prong grounded receptacle required.

⚠ CAUTION

Do not use an extension cord with this appliance.

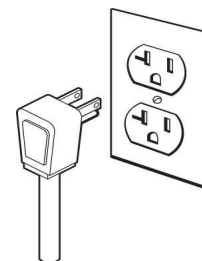

INSTALLING THE ANTI-TIP DEVICE

CAUTION

Anti - Tip Device

A cabinet “anti-tip” device is mounted to the back of your refrigerated drawer unit. If your installation is a built – in undercounter application with a countertop directly above the unit this item can be removed, it does not need to be applied. If your unit is a freestanding application with no countertop directly above the top of the unit, you must apply this feature to prevent the unit from tipping forward when the drawers are pulled out. The anti-tip device is installed on the back of the unit. The anti-tip device reduces the chance of personal injury as well as property damage when properly installed between the back of the unit and the adjacent wall. Please see the following instructions for installing the anti-tip device.

1. Push the unit against the wall so the anti-tip bracket is flush to the wall adjacent to the back panel. Level the unit with the leveling legs provided in the cabinet bottom. (See Leveling Legs on page 3).
2. Using a pencil and the bracket as a template, trace the bracket on the wall, making sure 2 of the screw holes are aligned with a stud in the wall.
3. Pull the unit away from the wall.
4. Remove the screws that connect the upper and lower sections of the anti-tip bracket.
5. Place the bracket on the wall and mark and drill $3/16$ " dia. Pilot holes for the provided $1/4$ " lag screws. Mount the lower section to the wall with the $1/4$ " lag screws.
6. Move the unit into place aligning the screw holes between the upper and lower brackets and secure with the screws removed in step 4.

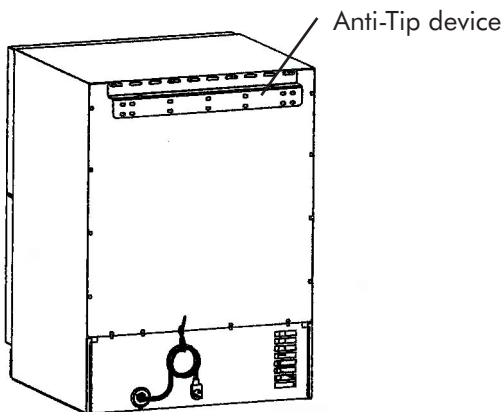
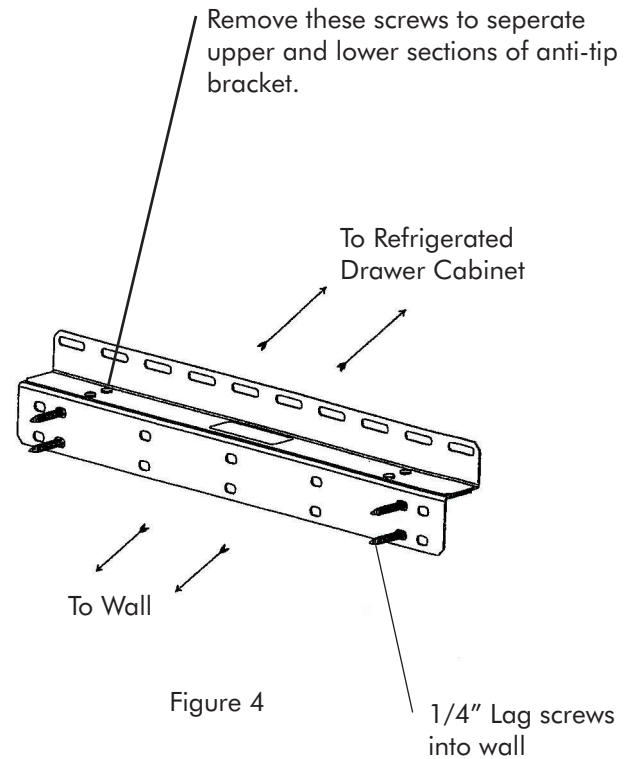
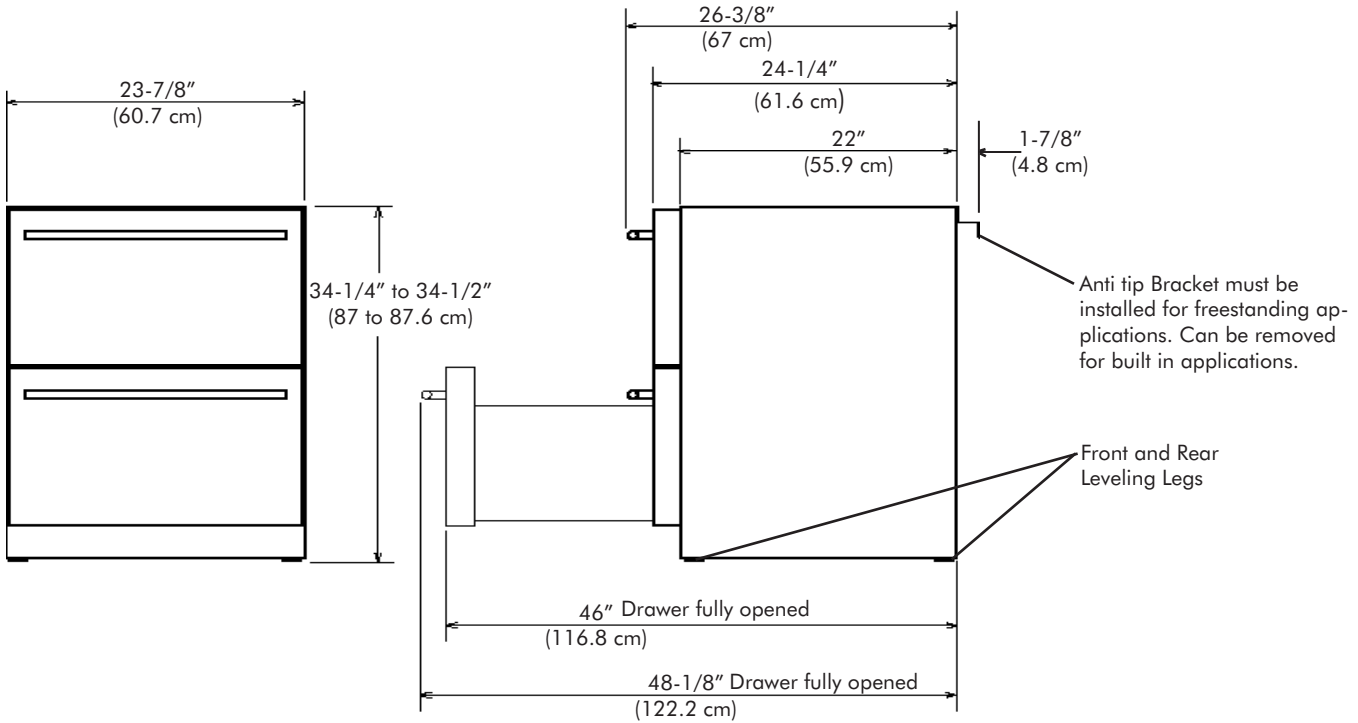
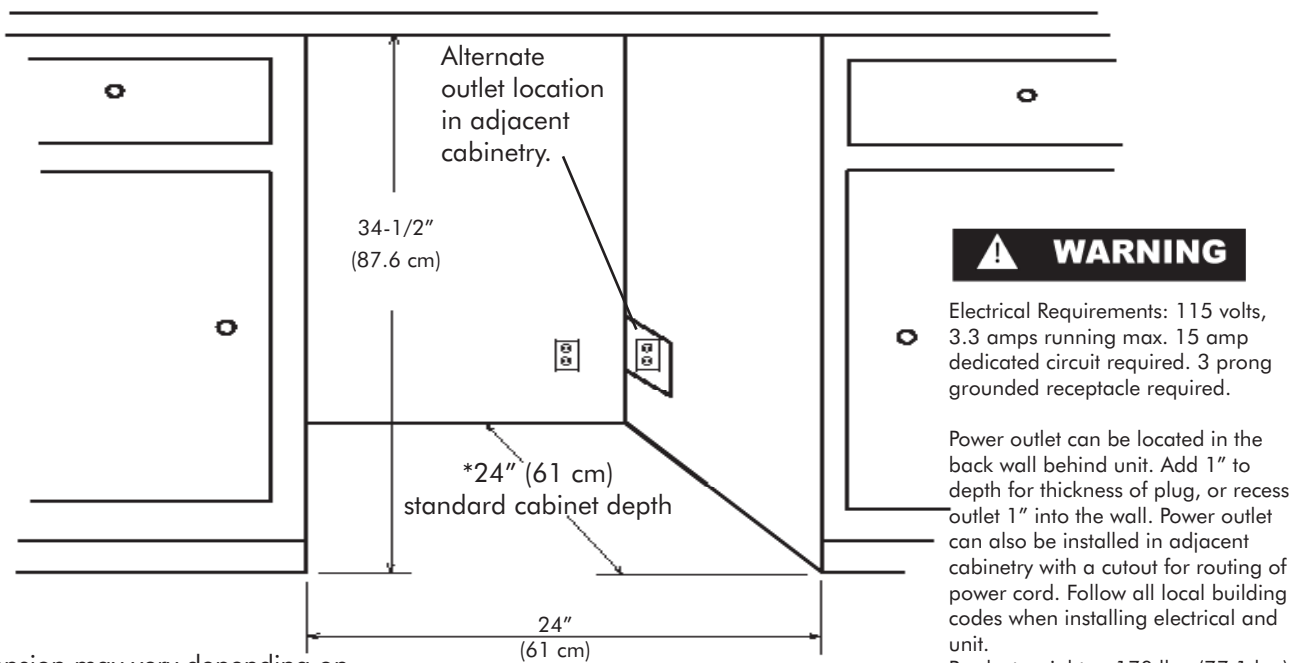

Figure 3

Dimensions Indoor Model 60RDE



Recommended Rough In Opening Dimensions, Indoor Model 60RDE



*Depth dimension may vary depending on each individual installation.

Dimensions for Indoor Model 60RDE Overlay Door

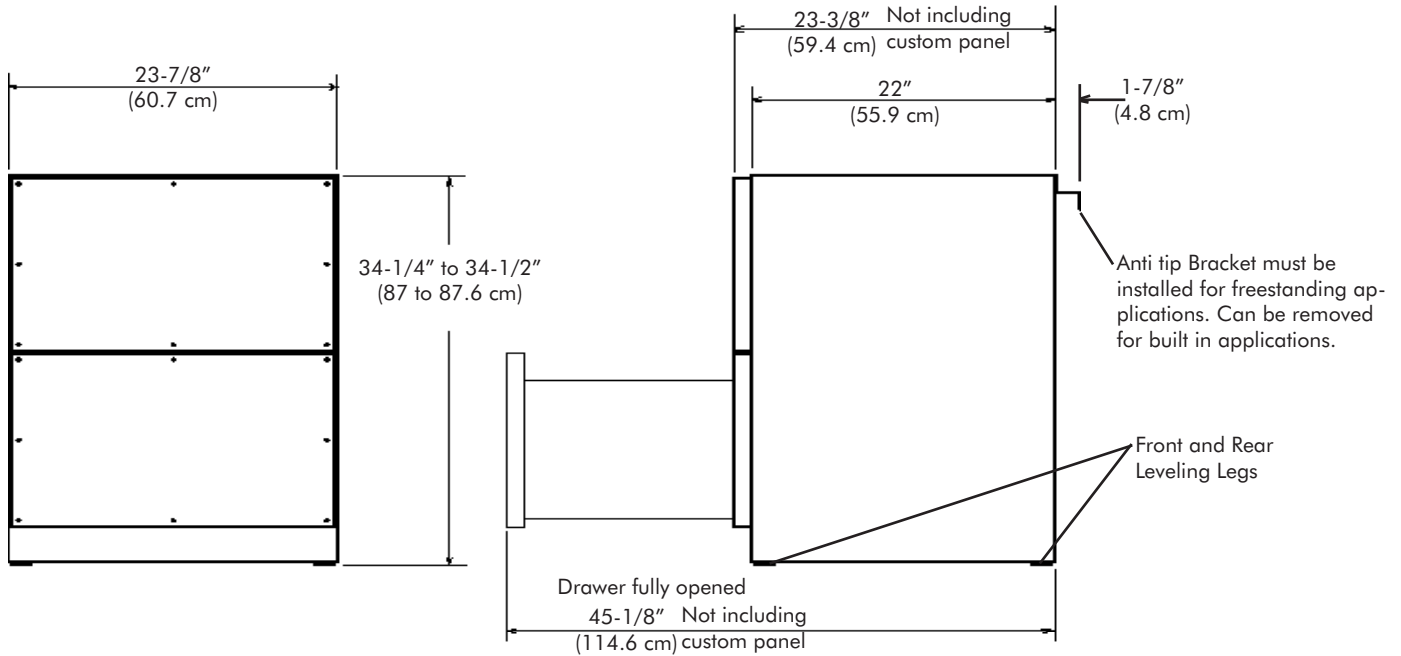

Recommended Rough In Opening Dimensions, Indoor Model 60RDE Overlay Door

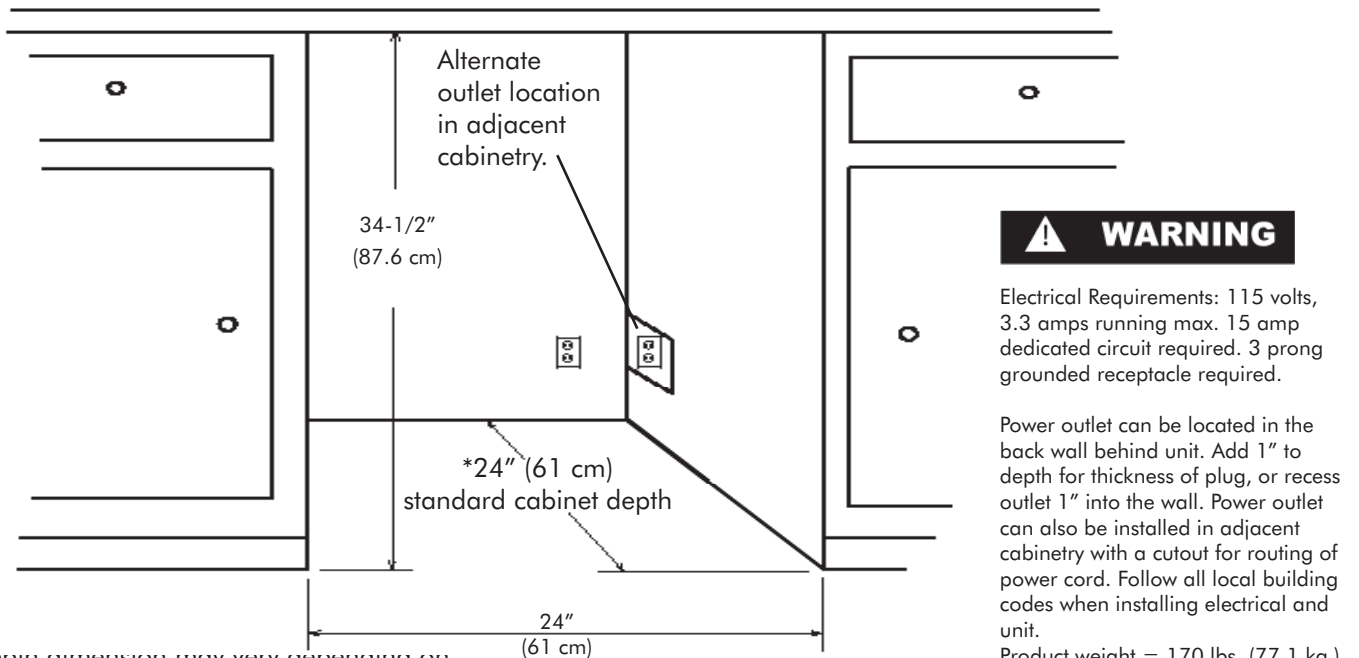

*Depth dimension may vary depending on each individual installation.

Dimensions for Outdoor Model 6ORDE

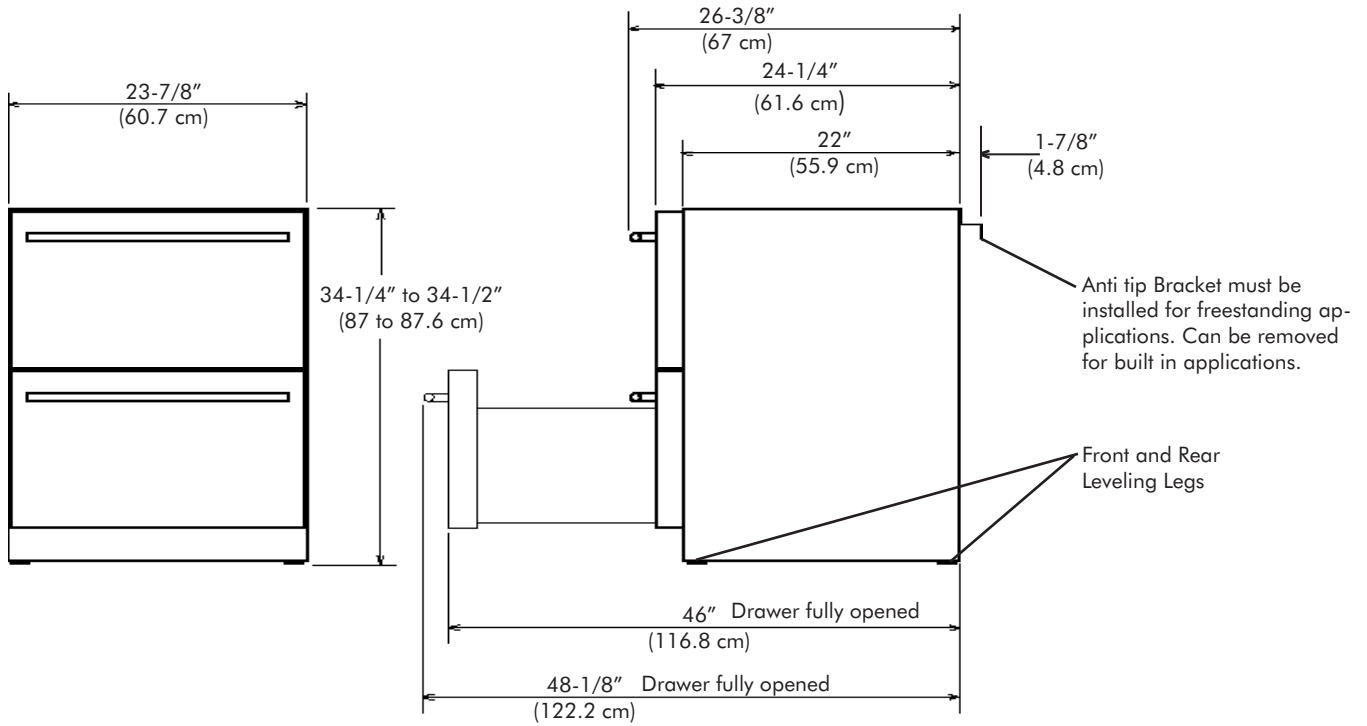

Recommended Rough In Opening Dimensions, Outdoor Model 6ORDE

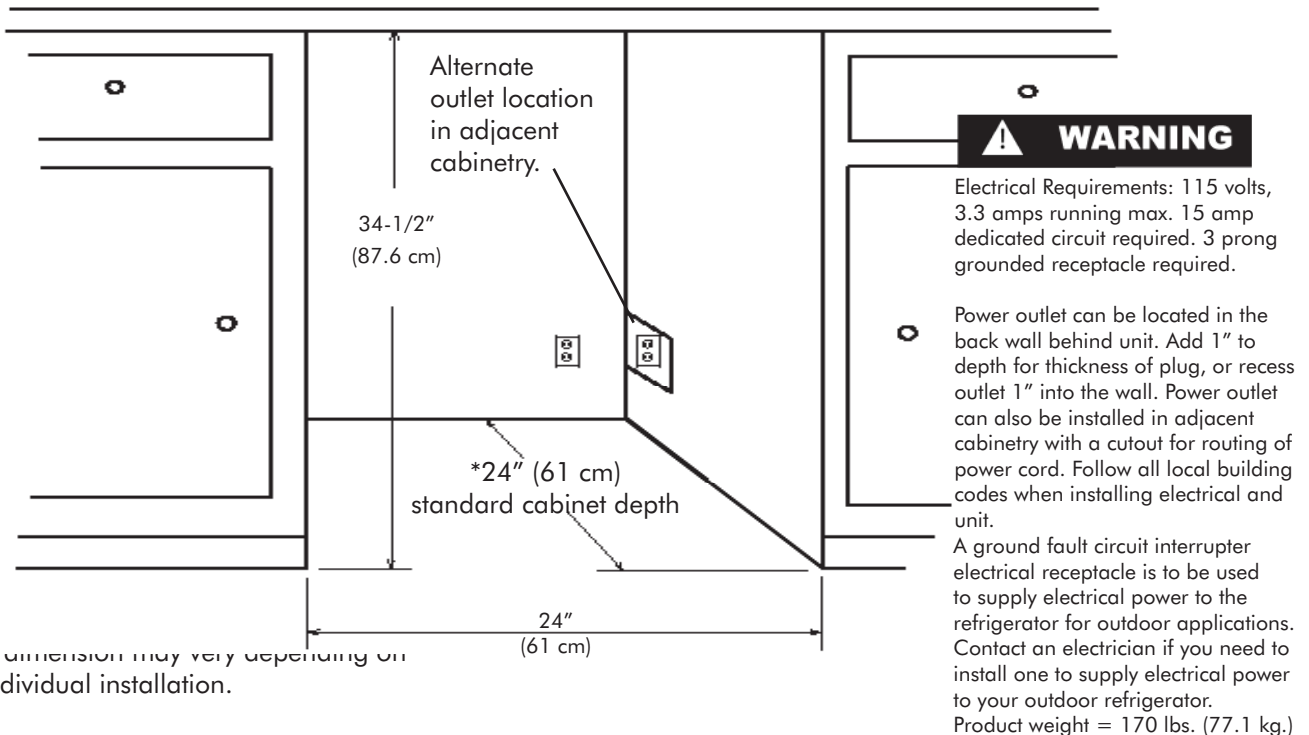

*Depth dimension may vary depending on each individual installation.

Dimensions for Indoor Model 80RDE

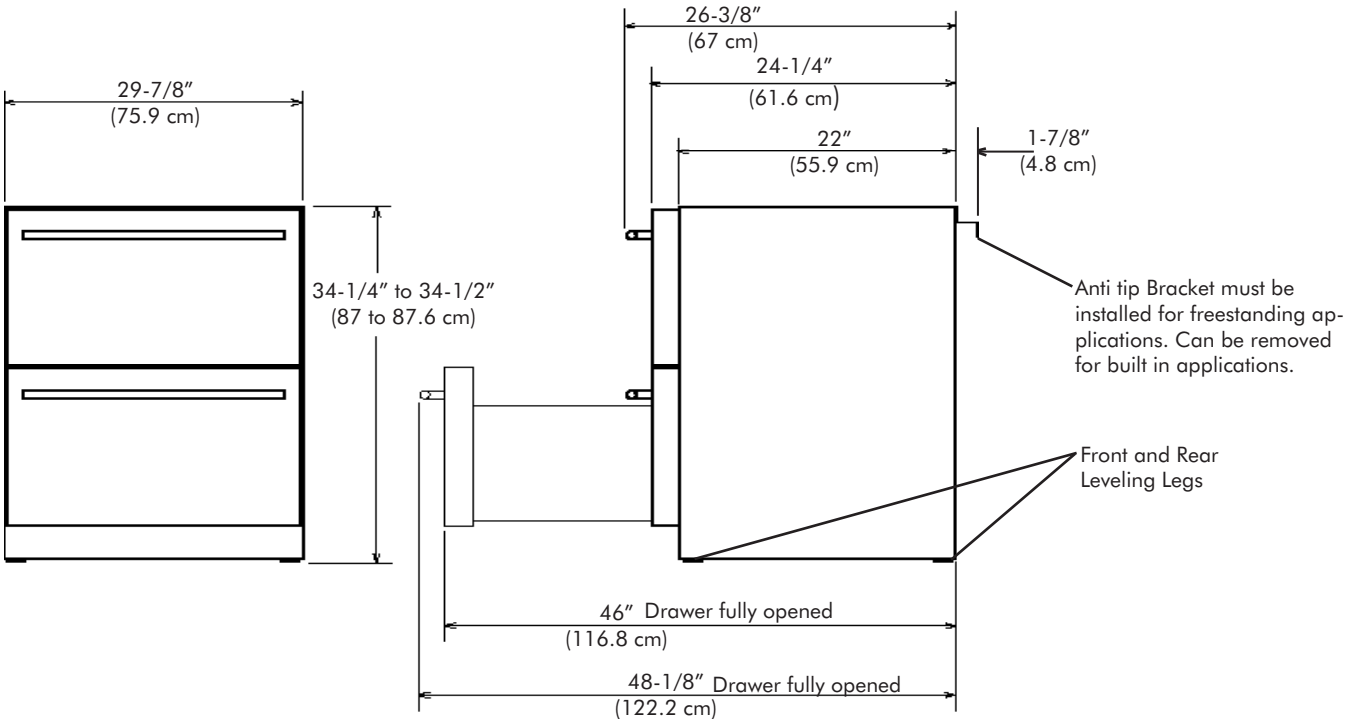

Recommended Rough In Opening Dimensions, Indoor Model 80RDE

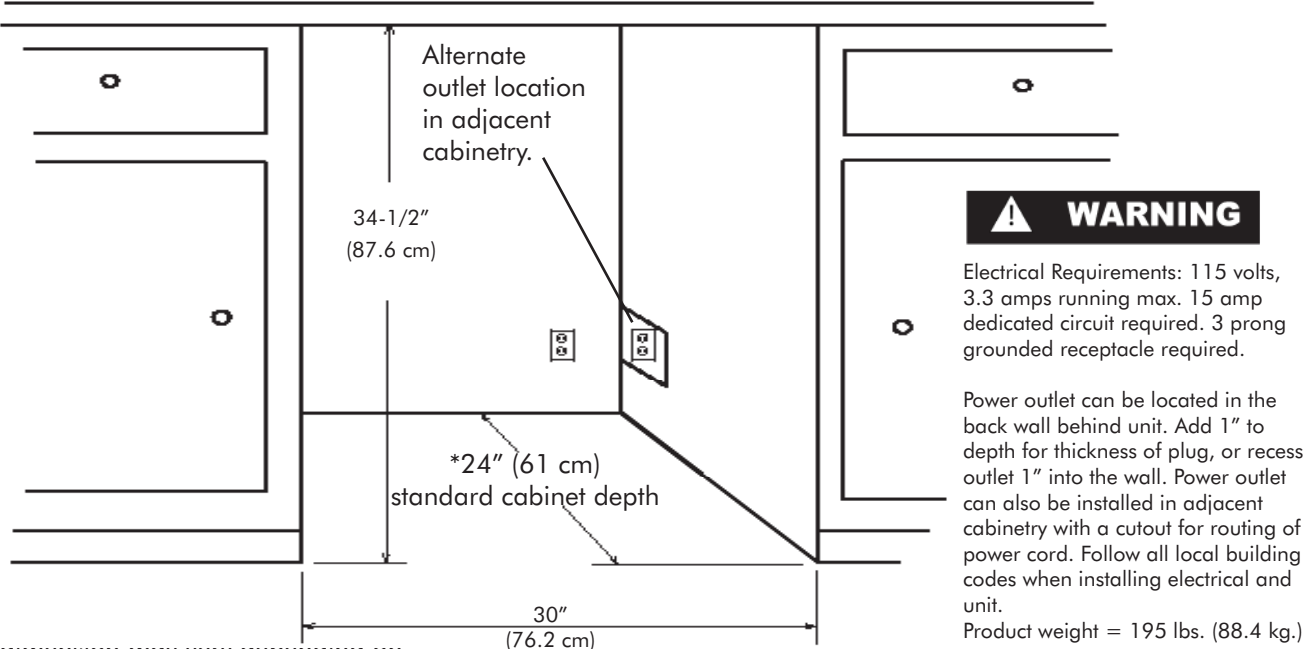

*Depth dimension may vary depending on each individual installation.

Dimensions for Indoor Model 80RDE Overlay Door

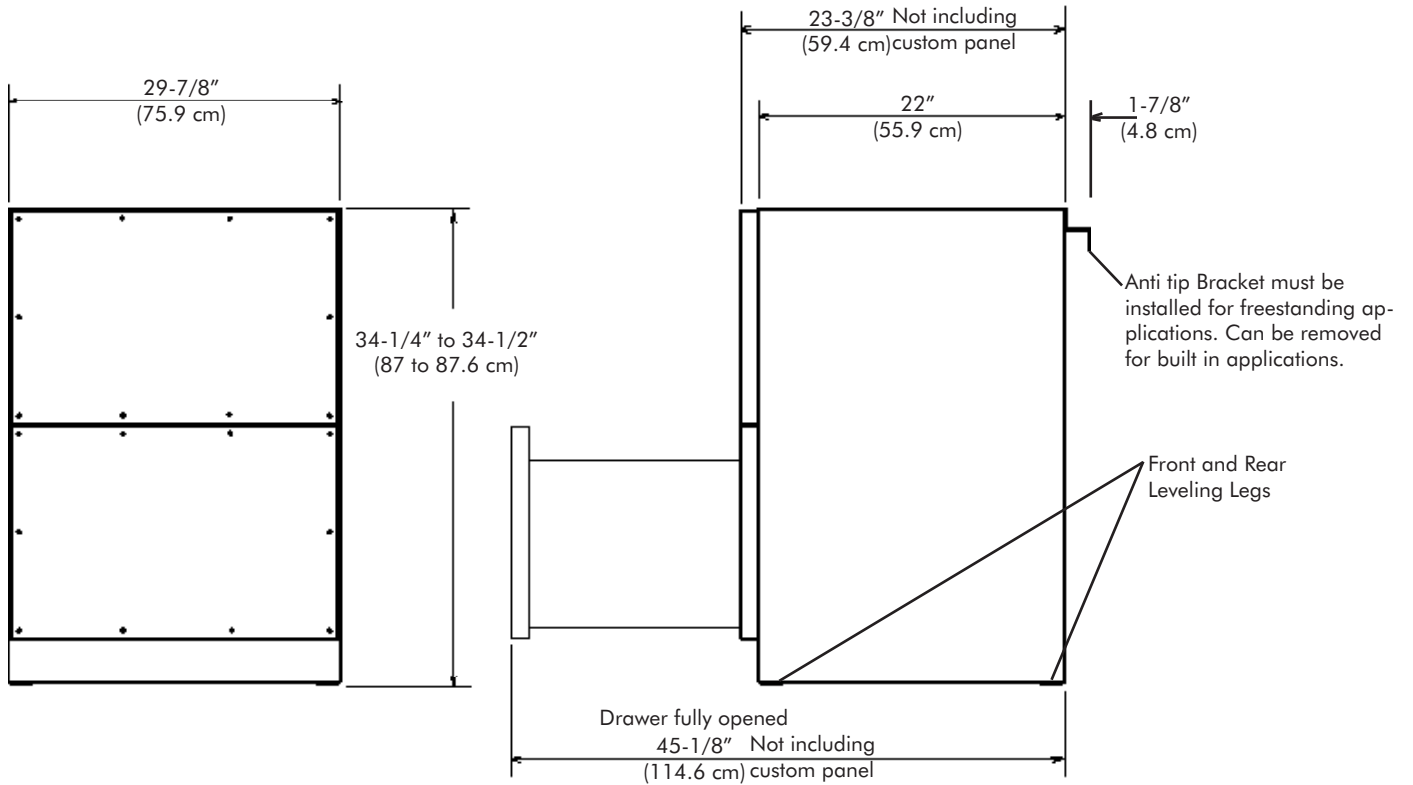

Recommended Rough In Opening Dimensions, Indoor Model 80RDE Overlay Door

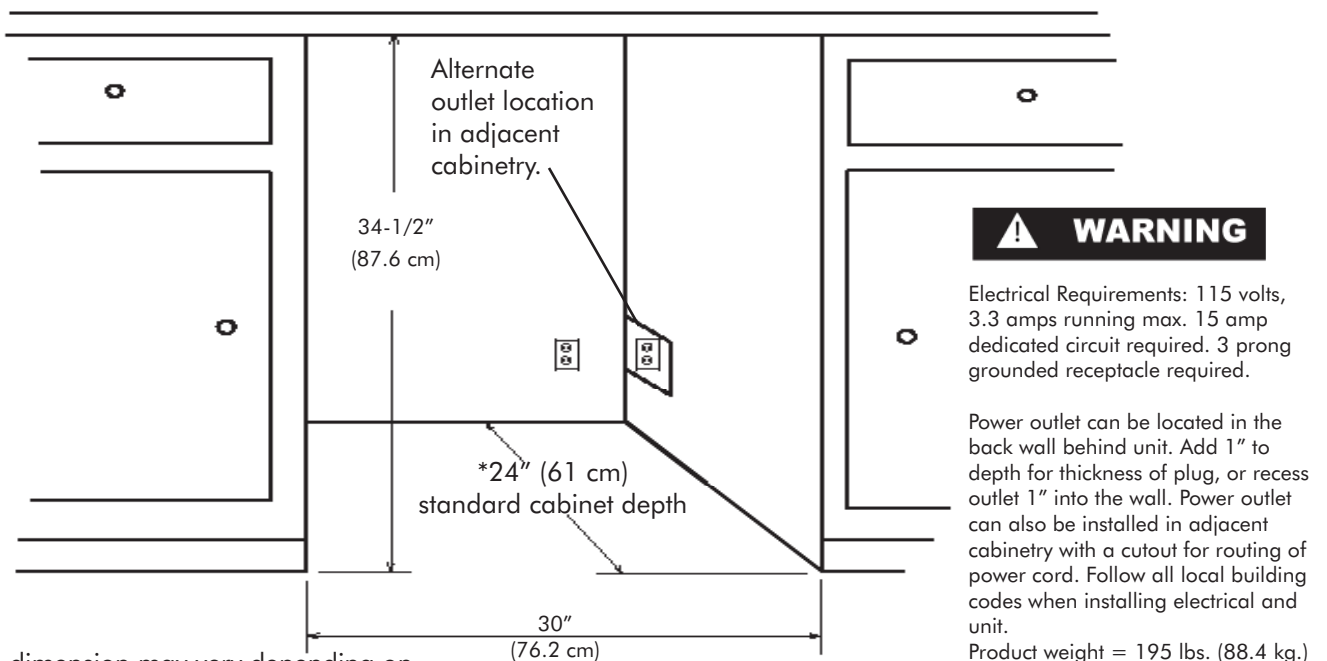

*Depth dimension may vary depending on each individual installation.

FOR MODELS 60RDE and 80RDE WITH OVERLAY PANELS INSTALLATION INSTRUCTIONS

CAUTION

Determine Wood Screw Requirements

1. A #8 pan head wood screw should be used to properly secure the overlay panel. A total of 8 screws per drawer for the 60 unit and 10 screws per drawer for the 80 unit will be required. (See Figure 9). Necessary screws are supplied with unit.
2. Use only pan head screws.
3. If your overlay panel is thinner than 5/8" (15.9 mm) you will need to purchase shorter screws.

Step 1: Remove Drawers from unit.

1. Remove drawer from the unit. Begin by pulling out the drawer. Locate the drawer lock which can be found on the outside of the cabinet slide (see Figure 5). Push the back of the drawer lock forward and then down, releasing the drawer from the cabinet slide (see Figure 6). Repeat this on the opposite side of the drawer. Lift the drawer up from the slides at a 90 degree angle to fully extricate the drawer from the cabinet (See Figure 7).
2. Remove the gasket from the drawer front. Do this by pulling the gasket out of the channel that holds it to the drawer front. This will expose the clearance holes for mounting the overlay panel. (See Figure 8).

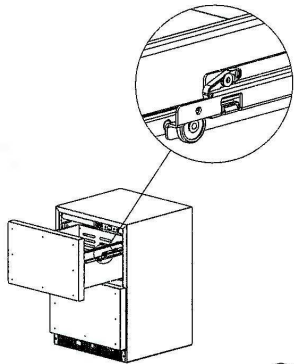

Figure 5

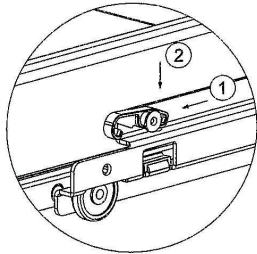

Figure 6

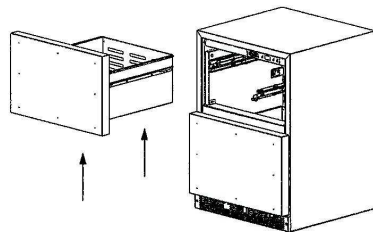

Figure 7

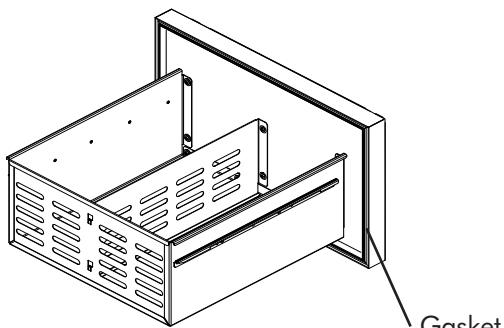

Figure 8

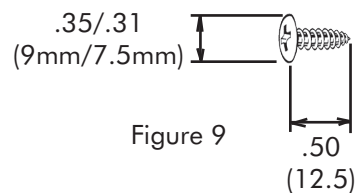

Figure 9

FULL OVERLAY PANEL INSTALLATION INSTRUCTIONS

Step 2: Size the Overlay Panel

Cut the overlay panel to the dimensions shown below. Use Figure 10 for the 60RDE Drawer, and Figure 11 for the 80RDE drawer.

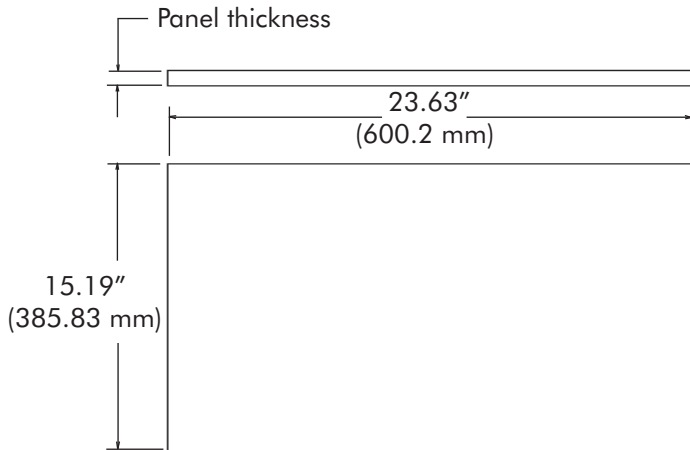

Figure 10
Face of 60RDE
Overlay Panel

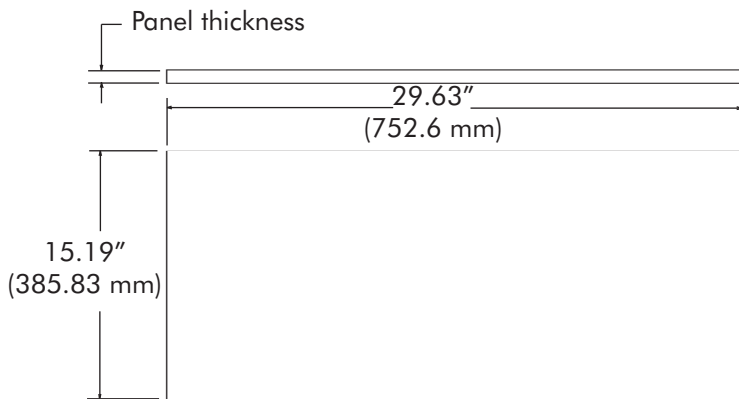

Figure 11
Face of 80RDE
Overlay Panel

Step 4: Attach the Overlay Panel to the Drawer

1. Set the overlay panel on drawer front face and align edges. (See Figure 12 below). Clamp panel in position and mark pilot hole locations. Pick the required pilot hole size from "Table A" below and drill the pilot holes ensuring not to drill all the way through the overlay panel.

Table A: Pilot Hole Drill Sizes for Wood Screws

Material Type	#8 Wood Screw
Hardwood	3/32 Dia. Pilot Hole
Softwood	5/64 Dia. Pilot Hole

2. Insert wood screws through clearance holes and tighten to secure overlay panel.
3. Reinstall gasket into channel. Make sure the corners are fully inserted.

Step 5: Reinstall the Drawers

1. Fully extend drawer slides and place drawer on slides. Be sure that drawer sits evenly on both slides.
2. Lock drawers into drawer slides. Push drawer locks down and then back to relock the drawer into the slide.

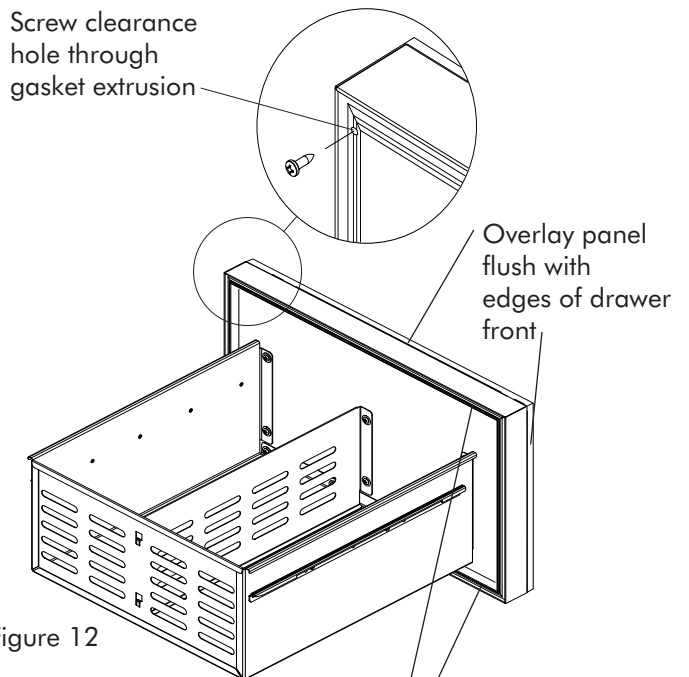
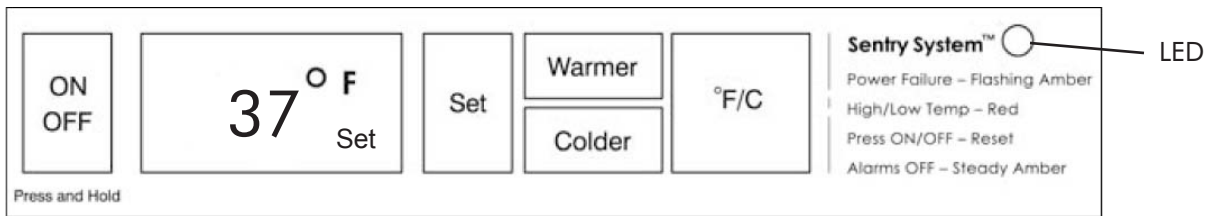

Figure 12

Using clearance holes in gasket channel mark hole locations onto panel

USING YOUR REFRIGERATOR DRAWERS

Figure 13



Start Your Appliance

Your refrigerated drawers have been fitted with a **Sentry System™** refrigeration monitor. It is located at the top front of the cabinet and can be accessed by opening the top drawer. Your appliance will start upon initial plug-in. On start the Sentry System™ monitor will flash amber. This is normal. Press the “ON/OFF” button and the appliance resets and the LED turns green. (Refer to Figure 13 above).

Set Your Temperature Mode

This product can display either Fahrenheit or Celsius. To do so, press the “°F/C” button on the display panel to change from one to the other.

Set the desired temperature

The available temperature range of the unit is from 33° to 47°F (1° to 8° C). This range allows flexibility of temperature preferences and provides the ideal storing and serving temperatures. The temperature is initially set in the factory at 37° F (3° C). The temperature set point can be lowered or raised by first pushing the “SET” button on the display pad. A “SET” icon will be displayed in the temperature display. Pressing and releasing either the “WARMER” or “COLDER” buttons located on the display pad will raise or lower the set temperature by one (1) degree at a time. As with any refrigeration product, there will be slight temperature variance at different locations within the cabinet.

Load Your Appliance

Load your appliance with your desired items. Please note that it may take up to 24 hours for your refrigerator to reach the desired temperature once loaded. This will primarily depend on the amount of contents loaded into the refrigerator and the amount of opening and closings of the drawers. Consider this when initially loading the drawers. Best results will be obtained by first allowing the drawers to “pull down” to your set temperature before loading the drawers.

Interior Light

The upper and lower interior lights make it easy to view your food and beverages. The light will always come on when either drawer is opened, except when unit is in Sabbath Mode.

Defrost Cycle

In order to maintain optimal performance, your refrigerator must periodically enter a defrost cycle to clear frost buildup. During the defrost cycles, the display will show DEF, and changes to setpoint and °F/°C setting may not be made.

Sabbath Mode

Your refrigerated drawers are equipped with a Sabbath Mode feature. By activating this mode, you will be disabling all displays, audible alarms and lights. To activate the Sabbath Mode, press and hold the “SET” button while pressing the “°F/C” button four (4) times within seven (7) seconds. To disable the Sabbath Mode, repeat the process. The Sabbath Mode will deactivate automatically after 72 hours.

USING YOUR REFRIGERATED DRAWERS

Figure 14

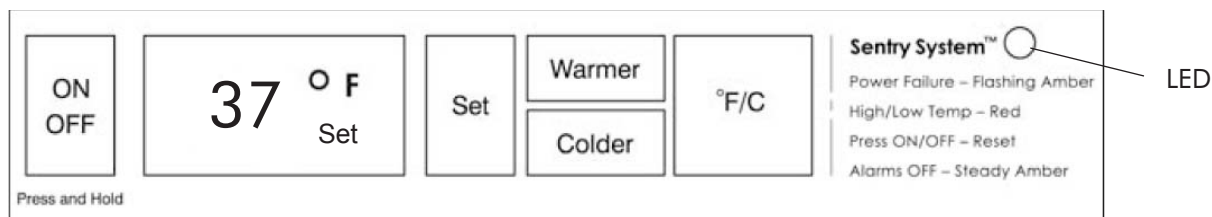

Warning Alarms

The Sentry System™ monitor will let you know if your unit is not functioning properly for the following reasons. Door ajar, high or low temperature, and power failure. These alarms are explained below.

Door Ajar Alarm

If the drawer has been left open for over five (5) minutes, the alarm will sound and the LED will flash green. This will stop as soon as the drawer is closed, or can be reset by pressing the "ON/OFF" button.

High and Low Temperature

If your unit reaches temperatures outside normal operating temperatures for your set point for more than one (1) hour, an alarm will sound and the LED will flash red. This will warn you that your contents have seen temperatures that may not be conducive for long-term storage. This alarm can be reset by pressing the "ON/OFF" button.

Power Failure

If your unit experiences a power failure, the LED will flash amber until the alarm is reset by pressing the "ON/OFF" button.

Reset Alarms

Press the "ON/OFF" button for approximately one (1) second. This will reset all audible and display alarms when the button is released.

Enable/Disable Sentry System™ Alarms

Press and hold the "SET" key for five (5) seconds to enable or disable the Sentry System™ alarms. LED will display a steady green when enabled or a steady amber when disabled.

Quick Reference Guide

The quick reference guide on page 14 and 15 can be removed from this manual and retained near the appliance for quick access to the Sentry System™ functions.

Sentry System™ “Basic” Function “Quick” Reference



Note: All keypad presses are confirmed with an audible tone when released.

Function	Function Access	Control Confirmation / Comment
Turn Unit On & Off	Pressing and holding the “On/Off” key for five seconds will turn the unit “ON” or “Off”.	The display will be blank when the refrigeration system is off. Lights will still function, but will time-out in 15 minutes after each activation if drawer is left open, to prevent overheating.
Adjust and View Temperature set-point	To adjust the temperature set-point, press the “SET” key and current set-point will be displayed. Use the “WARMER” or “COLDER” keys to adjust set-point temperature.	“SET” will appear in temperature display when in set-point mode. “SET” mode will automatically time-out in ten (10) seconds if no keypad activity occurs, or you may exit “SET” mode by pressing the “SET” key a second time.
Display “Actual” Temperature	The display represents real time monitoring. Some temperature fluctuation around the set-point will be noticeable as the refrigeration system cycles on and off to maintain the desired temperature.	Temperature variation in “compartment” air, above and below set-point, is a normal effect of refrigeration system cycling on and off. Stored items will not experience the full temperature swing of the compartment air due to the dampening effect of their thermal mass.
Select °F or °C Display	Pressing the “°F/°C” key will toggle the display between Fahrenheit and Centigrade temperature display.	i.e. 55°F = 13°C
Sabbath Mode	Press and hold the “SET” key while pressing the “°F/°C” key four (4) times in seven (7) seconds.	The display will flash “SA” seven (7) times, then the unit will enter Sabbath Mode. The display, audible alarms, LED, and lights will be disabled. Sabbath Mode will automatically time-out in 72 hours, or can be exited by repeating the enabling process.
Sentry System™ alarms	No action required. System monitoring is automatically enabled unless system has been disabled (see below).	Sentry System™ LED displays a steady green when Sentry System™ is enabled.
Drawer Ajar Alarm	No action required if Sentry System™ is enabled.	Audible alarm will sound 3 times every 30 seconds, the LED will flash green. Close drawer to reset alarm.
High/Low Temp Alarm	No action is required if Sentry System™ is enabled. NOTE: This alarm may occur when changing set-points and/or high usage, this is normal.	Alarm will sound 6-times every minute and LED will flash red if product temperature excursions occur for a duration outside acceptable limits.
Power Failure Alarm	No action required if Sentry System™ is enabled. NOTE: Alarm will occur upon initial installation, since unit was run at the factory to verify quality, this is normal.	LED will flash amber whenever power is interrupted to unit. There is no audible signal. Press ON/OFF button to reset alarm.
Reset Alarms	Close drawer to reset “DOOR AJAR” alarm. Press the “ON/OFF” key to reset all other alarms.	Note that although pressing the “ON/OFF” key resets the alarms, the alarm will resume if the “alarm condition” still exists.
Enable / Disable Sentry System™ alarms	Press and hold the “SET” key for five (5) seconds to enable or disable the Sentry System™ alarms.	LED displays a steady green when alarms are enabled. LED displays a steady amber when they are disabled.

Sentry System™ “Troubleshooting” Function “Quick” Reference



Note: All keypad presses are confirmed with an audible tone when released.

Function	Function Access	Control Confirmation / Comment																																																							
Show Room Mode	<p>Enable the showroom mode by pressing and holding the “ON/OFF” key while performing a “Power On Reset” (POR). i.e. disconnect and reconnect the power supply to the unit. Exit Showroom Mode by initiating a POR only.</p>	<p>Show Room Mode will disable the refrigeration system and fans while allowing the internal lights, display, and user interface panel to function. Lights will time-out after 15 minutes of continuous on-time while in Show Room Mode as a safety feature. The 15 minute light on time can be reactivated by closing and opening the door or by pressing the “LIGHT” key.</p>																																																							
Error Codes	<table border="1" data-bbox="513 852 667 1551"> <tr> <td>E1</td> <td>Compressor fault, (high/low amps)</td> </tr> <tr> <td>E2</td> <td>Condenser fan motor fault, (high/low amps)</td> </tr> <tr> <td>E3</td> <td>Evaporator thermistor “sensor B” fault, (out of range)</td> </tr> <tr> <td>E4</td> <td>Display thermistor “sensor A” fault, (out of range)</td> </tr> </table> <p>Please call a qualified service technician if any of these codes are displayed.</p>	E1	Compressor fault, (high/low amps)	E2	Condenser fan motor fault, (high/low amps)	E3	Evaporator thermistor “sensor B” fault, (out of range)	E4	Display thermistor “sensor A” fault, (out of range)	<p>Service Diagnostics Mode enables service technicians to identify the firmware and software versions, test status of “model specific” system components and sensors, and change state of components where applicable, (i.e. -compressor “ON/OFF” etc.). While in Service Diagnostics Mode, tests are incremented by pressing the “SET” key and specific component state can be changed to “on” or “off” by pressing the “WARMER” or “COLDER” keys respectively. The following component tests are available:</p>																																															
E1	Compressor fault, (high/low amps)																																																								
E2	Condenser fan motor fault, (high/low amps)																																																								
E3	Evaporator thermistor “sensor B” fault, (out of range)																																																								
E4	Display thermistor “sensor A” fault, (out of range)																																																								
Service Diagnostics	<p>To enter and exit Service Diagnostics Mode, press and hold the “WARMER” key while pressing the “COLDER” key four (4) times in five (5) seconds. Service Diagnostics Mode will automatically exit after five (5) minutes of no keypad entry.</p> <p>Display Error Code Reference: The microprocessor in the control continually monitors critical refrigeration system components for proper operation. If component parameters exceed normal operation specifications, the display will automatically flash the respective error code as follows:</p>	<table border="1" data-bbox="964 113 1430 831"> <thead> <tr> <th>Test #</th> <th>Component Description</th> <th>OK</th> <th>Off/ Open</th> <th>On/ Shorted</th> </tr> </thead> <tbody> <tr> <td>0</td> <td>Temperature Sensor, Upper</td> <td>0-</td> <td>00</td> <td>01</td> </tr> <tr> <td>1</td> <td>Temperature Sensor, Lower</td> <td>1-</td> <td>10</td> <td>11</td> </tr> <tr> <td>2</td> <td>Compressor</td> <td>n/a</td> <td>20</td> <td>21</td> </tr> <tr> <td>3</td> <td>Interior / Ice Maker Fan</td> <td>n/a</td> <td>30</td> <td>31</td> </tr> <tr> <td>4</td> <td>Reverse Gas Solenoid</td> <td>n/a</td> <td>40</td> <td>41</td> </tr> <tr> <td>5</td> <td>Condenser Fan</td> <td>n/a</td> <td>50</td> <td>51</td> </tr> <tr> <td>6</td> <td>Mullion Heater</td> <td>n/a</td> <td>60</td> <td>61</td> </tr> <tr> <td>7</td> <td>Door A Sense</td> <td>n/a</td> <td>70</td> <td>71</td> </tr> <tr> <td>8</td> <td>Door B Sense</td> <td>n/a</td> <td>80</td> <td>81</td> </tr> <tr> <td>9</td> <td>Door C Sense</td> <td>n/a</td> <td>90</td> <td>91</td> </tr> </tbody> </table> <p>Available Status Indicators</p> <p>NOTE: The Door Sense is located between the Upper Compartment Display and the “ON/OFF” key and can be tested with any magnet. Door sense “C” (Test #9) is in the menu but not available on drawer units.</p>	Test #	Component Description	OK	Off/ Open	On/ Shorted	0	Temperature Sensor, Upper	0-	00	01	1	Temperature Sensor, Lower	1-	10	11	2	Compressor	n/a	20	21	3	Interior / Ice Maker Fan	n/a	30	31	4	Reverse Gas Solenoid	n/a	40	41	5	Condenser Fan	n/a	50	51	6	Mullion Heater	n/a	60	61	7	Door A Sense	n/a	70	71	8	Door B Sense	n/a	80	81	9	Door C Sense	n/a	90	91
Test #	Component Description	OK	Off/ Open	On/ Shorted																																																					
0	Temperature Sensor, Upper	0-	00	01																																																					
1	Temperature Sensor, Lower	1-	10	11																																																					
2	Compressor	n/a	20	21																																																					
3	Interior / Ice Maker Fan	n/a	30	31																																																					
4	Reverse Gas Solenoid	n/a	40	41																																																					
5	Condenser Fan	n/a	50	51																																																					
6	Mullion Heater	n/a	60	61																																																					
7	Door A Sense	n/a	70	71																																																					
8	Door B Sense	n/a	80	81																																																					
9	Door C Sense	n/a	90	91																																																					

CARE AND CLEANING OF YOUR REFRIGERATED DRAWERS

Condenser

The machine compartment located beneath the cabinet does not require frequent cleaning; however, satisfactory performance depends on adequate ventilation. Be sure nothing obstructs the required air flow openings in front of the cabinet. At least once or twice a year, brush or vacuum lint and dirt from the front grille openings. See Figure 1 on page 3.

Cabinet

The painted cabinet can be washed with either a mild soap and water and thoroughly rinsed with clear water. NEVER use abrasive scouring cleaners.

Interior

Wash interior compartment with mild soap and water. Do NOT use an abrasive cleaner, solvent, polish cleaner or undiluted detergent.

Care of Unit

1. Avoid leaning on the drawer fronts, you may bend the drawer slides or tip the unit.
2. Exercise caution when sweeping, vacuuming or mopping near the front of the unit. Damage to the grille can occur.
3. Periodically clean the interior of the unit as needed.
4. Periodically check and/or clean the front grille as needed.

AVAILABLE OPTIONS FOR YOUR MARVEL DRAWER REFRIGERATOR

E-Z Stor Storage System

Removable stainless steel bins with clear plastic lids can be moved to prep, cook, or serving areas as desired. Available for 60RDE and 80RDE upper and lower drawers.

P/N 42245441 for 60 upper or lower drawers

P/N 42245442 for 80 upper drawer

P/N 42245443 for 80 lower drawer

For further information on available options visit the Marvel website at www.marvelrefrigeration.com or contact your Marvel dealer.

NOTE

When installing these options in the drawers the standard drawer divider will have to be removed.

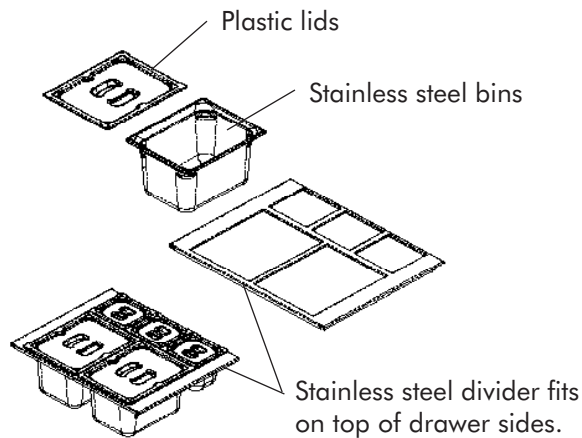

Figure 15
E-Z-Store Storage System

Drawer Dividers

Fully adjustable stainless steel drawer dividers allow for optimum storage and organization of storage space.

P/N 42245444 for 60RDE upper drawer

P/N 42245445 for 60RDE lower drawer

P/N 42245446 for 80RDE upper drawer

P/N 42245447 for 80RDE lower drawer

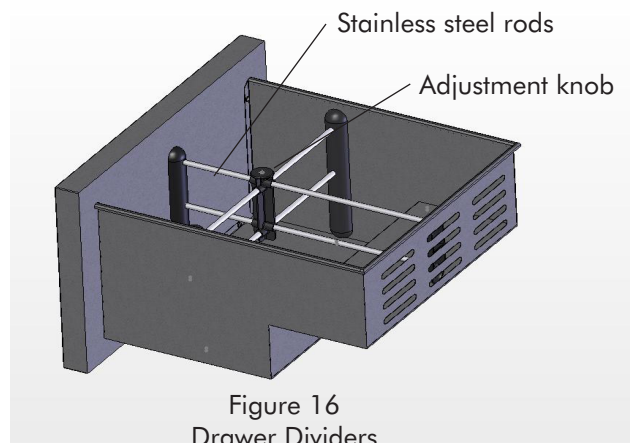

Figure 16
Drawer Dividers

TROUBLESHOOTING YOUR REFRIGERATED DRAWERS

Before You Call for Service

If the unit appears to be malfunctioning, read through this manual first. If the problem persists, check the troubleshooting guide below. Locate the problem in the guide and refer to the cause and its remedy before calling for service. The problem may be something very simple that can be solved without a service call. Some remedies listed in the Troubleshooting Guide are very complex. Consulting or contracting a qualified service technician may be necessary.

If Service is Required:

- If the product is within the first year warranty period please call Marvel Customer Service at 800.223.3900 for directions on how to obtain warranty coverage in your area.
- If the product is outside the first year warranty period, Marvel Customer Service can provide recommendations of service centers in your area. A listing of authorized service centers is also available at www.marvelrefrigeration.com under the service and support section.

WARNING

Electrocution Hazard - Never attempt to repair or perform maintenance on the unit until the main electrical power has been disconnected.

- In all correspondence regarding service, be sure to give the model number, serial number, and proof of purchase.
- Try to have information or description of nature of the problem, how long the unit has been running, the room temperature, and any additional information that may be helpful in quickly solving the problem.
- Fill in pertinent information below regarding your product for future reference.

For You Records	
Date of Purchase	
Dealer's name	
Dealer's Address	
Dealer's City	
Dealer's State	
Dealer's Zip Code	
Appliance Serial Number	
Appliance Model Number	
Date Warranty Card Sent (Must be within 10 days of purchase).	

Problem	Possible Cause	Remedy
Unit not cold enough Adjust temperatures (See "Set the Controls" on page 13)	<ul style="list-style-type: none"> • Control set too warm • Airflow to front grille blocked. • Excessive usage or prolonged drawer openings. • Drawer gasket not sealing properly. 	<ul style="list-style-type: none"> • Adjust temperature colder. Allow 24 hours for temperature to stabilize. • Airflow must not be obstructed to front grille. See "clearances" on page 3. • Allow temperature to stabilize for at least 24 hours. • Adjust or replace drawer gasket.
Unit too cold Adjust temperatures (See "Set the Controls" on page 13)	<ul style="list-style-type: none"> • Control set too cold 	<ul style="list-style-type: none"> • Adjust temperature warmer. (See page 12, "set the desired temperature"). Allow 24 hours for temperature to stabilize.
No interior light in drawer compartments.	<ul style="list-style-type: none"> • Failed LED interior light assembly 	<ul style="list-style-type: none"> • Contact a qualified Marvel service technician.
Light will not go out when drawer is closed	<ul style="list-style-type: none"> • Drawer not activating light switch. 	<ul style="list-style-type: none"> • Unit not level, level unit, (See page 3, "leveling legs")
Noise or Vibration	<ul style="list-style-type: none"> • Unit not level 	<ul style="list-style-type: none"> • Level unit, see "Leveling Legs" on page 3.
Unit will not run.	<ul style="list-style-type: none"> • Unit turned off • Power cord not plugged in. • No power at outlet. 	<ul style="list-style-type: none"> • Turn unit on. See "Start your Appliance" on page 13. • Plug in power cord. • Check house circuit.

HOUSEHOLD PRODUCT WARRANTY

Entire Product

Limited One Year Parts and Labor Warranty

Marvel warrants that it will supply all necessary parts and labor to repair or replace in the end user's home or office, any component which proves to be defective in material or workmanship, subject to the condition and exclusions stated below, for a period of one year from the date of purchase by the end user.

Additional Second Through Fifth Year

Limited Parts Only Warranty

During the four years following expiration of the one year limited warranty, Marvel will supply replacement parts for the hermetically sealed refrigeration system which consists of the compressor, condenser, drier, accumulator, bypass valve, connecting tubing and the evaporator that are proven to be defective due to workmanship or materials subject to the conditions and exclusions below.

The above warranties do not cover:

- Shipping costs of replacement parts or returned defective parts.
- Customer education or instructions on how to use the appliance.
- Any content loss due to product failure.
- Removal or installation of product.

Nor do the above warranties cover failure of this product or its components due to:

- Transportation or subsequent damages.
- Commercial use or use other than normal household or small office.
- Improper installation, misuse, abuse, accident or alteration, use of wiring not conforming to electrical codes, low or high voltages, failure to provide necessary maintenance, or other unreasonable use.

Parts or Service

Not Supplied or Designated by Marvel

The above warranties also do not apply if:

- The original bill of sale, deliver date, or serial number cannot be verified.
- Defective parts are not returned for inspection if so requested by Marvel.
- The refrigeration equipment is not in the possession of the original end use purchaser.

The warranties set forth herein are the only warranties extended by Northland-Marvel. Any implied warranties, including the implied warranty of merchantability, are limited to the duration of these express warranties. In no event shall Northland-Marvel be liable for any consequential or incidental damages or expenses resulting from breach of these or any other warranties, whether express or implied.

Some states do not allow the exclusion or limitation of consequential damages or a limitation on how long an implied warranty lasts, so the above exclusion or limitation may not apply to you. This warranty gives you specific legal rights and you may have other rights that may vary from state to state.

No person, firm, or corporation is authorized to make any other warranty or assume any other obligation for Northland-Marvel. These warranties apply only to products used in any of the fifty states of the United States and the District of Columbia.

To obtain performance of this warranty, report any defects to:

Northland-Marvel
P.O. Box 400
1260 E. Van Deinse St.
Greenville MI 48838

Phone: 800.223.3900



PART OF THE **AGA** RANGEmaster GROUP

Northland-Marvel
P.O. Box 400
1260 E. Van Deinse St.
Greenville MI 48838

800.223.3900

41011754-EN Rev H
11/10/09

www.marvelrefrigeration.com

All specifications and product designs subject to change without notice. Such revisions do not entitle the buyer to corresponding changes, improvements, additions, replacements or compensation for previously purchased products.