

National Student Loan Data System
Enrollment Reporting File (XML Schema)

April 6, 2012

1. NSLDS Enrollment Reporting File Using XML

The NSLDS Enrollment Reporting process requires schools to certify the enrollment status of students receiving federal student aid. The batch file process allows a school to designate the file format that will be used for the enrollment data exchange via the Student Aid Internet Gateway (SAIG). Schools will be able to trade batch enrollment data with NSLDS using an enhanced fixed-width flat file, a comma separated value (CSV) file, or XML. Schools will designate their choice on the [NSLDS Professional Access Web site](#).

NSLDS will initiate the enrollment reporting roster in the file layout selected and expect the roster submittal file to be returned in the same format. NSLDS will respond with the error/acknowledgement file and expect the error correction submittal file also using that same format. The Enrollment Roster and error/acknowledgement files will be sent from NSLDS with the SAIG message class EFRXMLOP. Return the Enrollment Submittal and error correction files to NSLDS using SAIG message class EFSXMLIN.

This document provides the XML schema developed by Federal Student Aid in partnership with the Postsecondary Electronic Standards Council (PESC), to be used for the enrollment reporting process beginning in July 2012. Additional information on this XML standard can be found at www.pesc.org.

NSLDS will provide more information regarding the NSLDS Enrollment Reporting Process in a future version of the NSLDS Enrollment Reporting User Guide.

2. XML Tag Definitions

NSLDSEnrollmentRecord

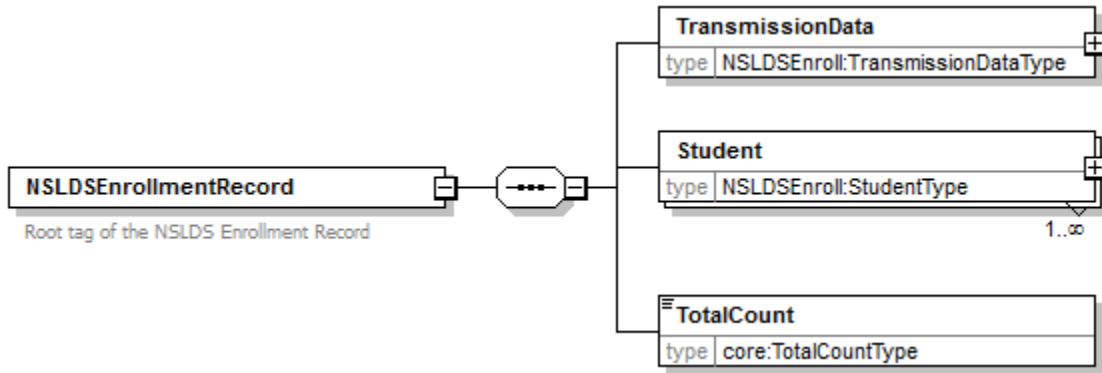

Tag name	Usage	Description	Format
NSLDSEnrollmentRecord	Required	Root element of XML document for NSLDSEnrollmentRecord_v1.0.0.xsd.	Aggregate minOcc 1 maxOcc 1
TransmissionData	Required	A group of elements containing routing and header information. Uses NSLDSEnroll:TransmissionDataType	Aggregate minOcc 1 maxOcc 1
Student	Required	A group of elements which provides details about the student for which enrollment is being reported. Uses NSLDSEnroll:StudentType	Aggregate minOcc 1 maxOcc ∞ repeatable as needed
TotalCount	Required	Count of total student records, i.e. student tags, contained in the file. Uses TotalCountType .	Integer minOcc 1 maxOcc 1

NSLDSEnroll:TransmissionDataType

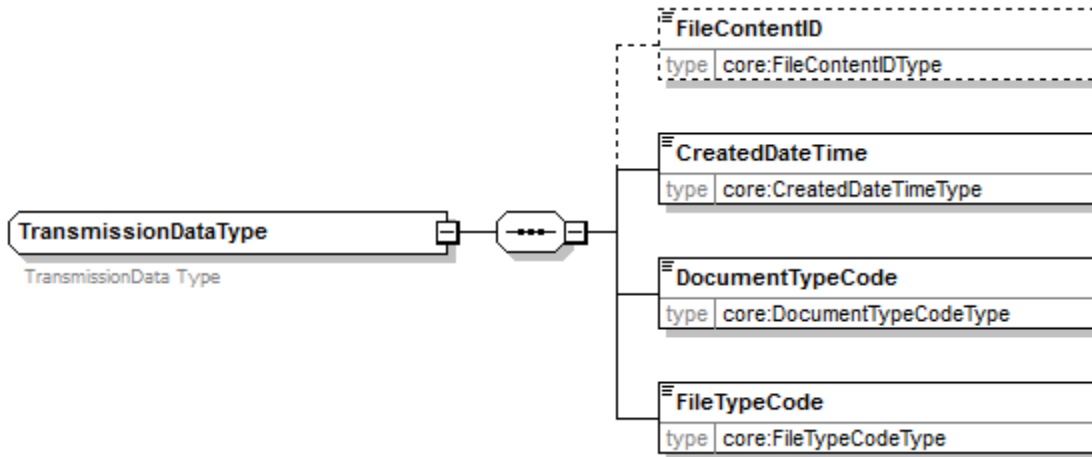

Tag name	Usage	Description	Format
FileContentID	Optional	Submitter defined indicator describing content of the file being exchanged.	Xs:string minOcc 0 maxOcc 1 maxLength 8
CreatedDateTime	Required	Date and time stamp with the document was created.	Xs:datetime ccyy-mm-dd hh:min:ss minOcc 1 maxOcc 1
DocumentTypeCode	Required	This basic component specifies a short description of the data in the document.	Enumeration: NSLDSEnrollmentSubmittal NSLDSErrorSubmittal minOcc 1 maxOcc 1
FileTypeCode	Required	Code indicating the type of file being transmitted.	Enumeration: Roster (flat file value = R) Error (flat file value = E) AdHoc (flat file value = A) SpecialProcessing (flat file value = Z) minOcc 1 maxOcc 1

NSLDSEnroll:StudentType

This diagram shows the overall structure of the student data that are expected to be submitted in the NSLDSEnrollmentRecord XML file. The table below explains each element.

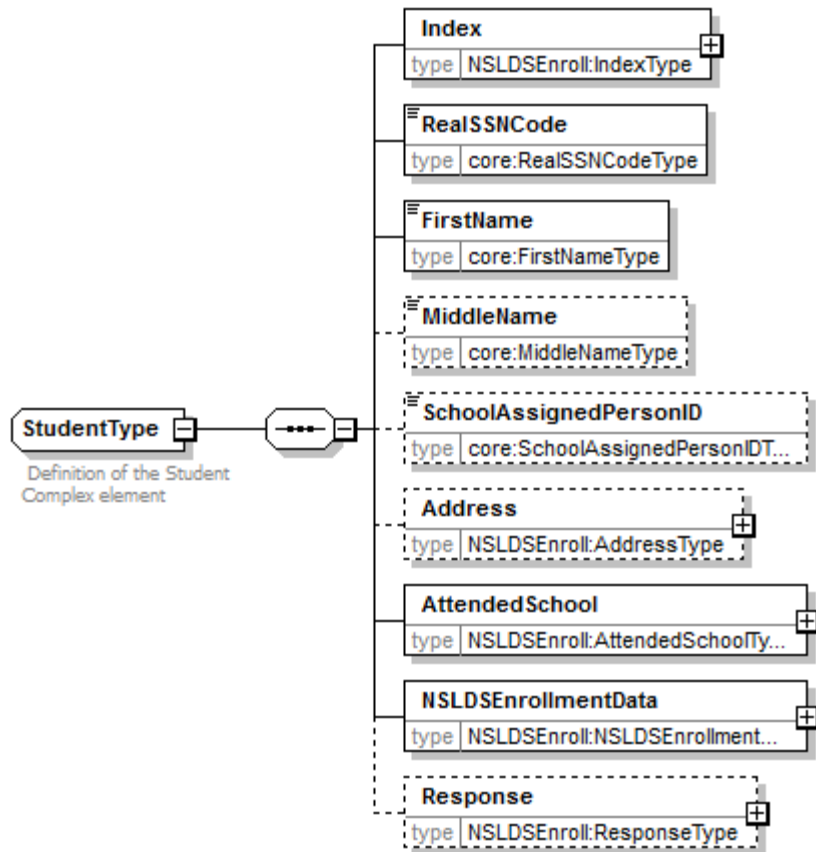

Tag name	Usage	Description	Format
Index	Required	Provides a logical grouping of components related to index information. Uses NSLDSEnroll:IndexType .	Aggregate minOcc 1 maxOcc 1
RealSSNCode	Required	Indicates whether the Social Security Number is a real Social Security Number or a pseudo number.	Enumeration: Real (flat file value = R) Pseudo (flat file value = P) minOcc 1 maxOcc 1
FirstName	Required	This basic component specifies the first	Xs: string

Tag name	Usage	Description	Format
		name by which a person is legally known. "NFN" for students with no first name.	minOcc 1 maxOcc 1 minLength 1 maxLength 35
Middlename	Optional	This basic component specifies the middle name by which a person is legally known.	Xs: string minOcc 0 maxOcc 1 minLength 1 maxLength 35
SchoolAssignedPersonID	Optional	Optional field used by schools to identify students within their own systems.	Xs: string minOcc 0 maxOcc 1 minLength 0 maxLength 20
Address	Optional	Provides a logical grouping of components related to a student address. Uses NSLDSEnroll:AddressType .	Aggregate minOcc 0 maxOcc 1
AttendedSchool	Required	Provides a logical grouping of components related to the school reporting enrollment information for the student. Uses NSLDSEnroll:AttendedSchoolType .	Aggregate minOcc 1 maxOcc 1
NSLDSEnrollmentData	Required	Provides a logical grouping of components related to NSLDS enrollment information being reported. Uses NSLDSEnroll:NSLDSEnrollmentDataTy pe	Aggregate minOcc 1 maxOcc 1
Response	Optional	Provides a logical grouping of components related to record response such as record-level error codes. Uses NSLDSEnroll:ResponseType .	Aggregate minOcc 0 maxOcc 1

TotalCountType

Used by elements:

- TotalCount

TotalCountType is an integer with values from 0 to 999999999 and is used to indicate a count of students in the NSLDS Enrollment Reporting record.

 TotalCount
type core:TotalCountType

NSLDSEnroll:IndexType

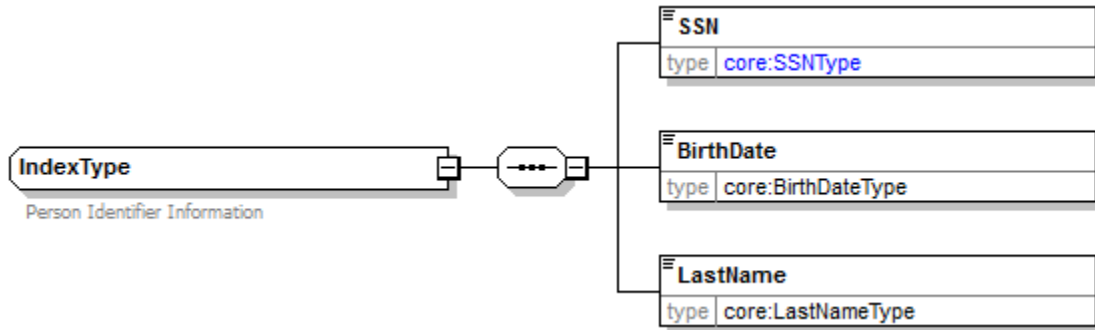

Tag name	Usage	Description	Format
SSN	Required	The current SSN for the student being reported.	Xs: string Pattern: /d{9} minOcc 1 maxOcc 1 maxLength 9
BirthDate	Required	The student's date of birth.	Xs: date ccyy-mm-dd minOcc 1 maxOcc 1
LastName	Required	The last name or surname by which the student is legally known. 'NLN' for students with no last name.	Xs: string minOcc 1 maxOcc 1 minLength 1 maxlength 35

NSLDSEnroll:AddressType

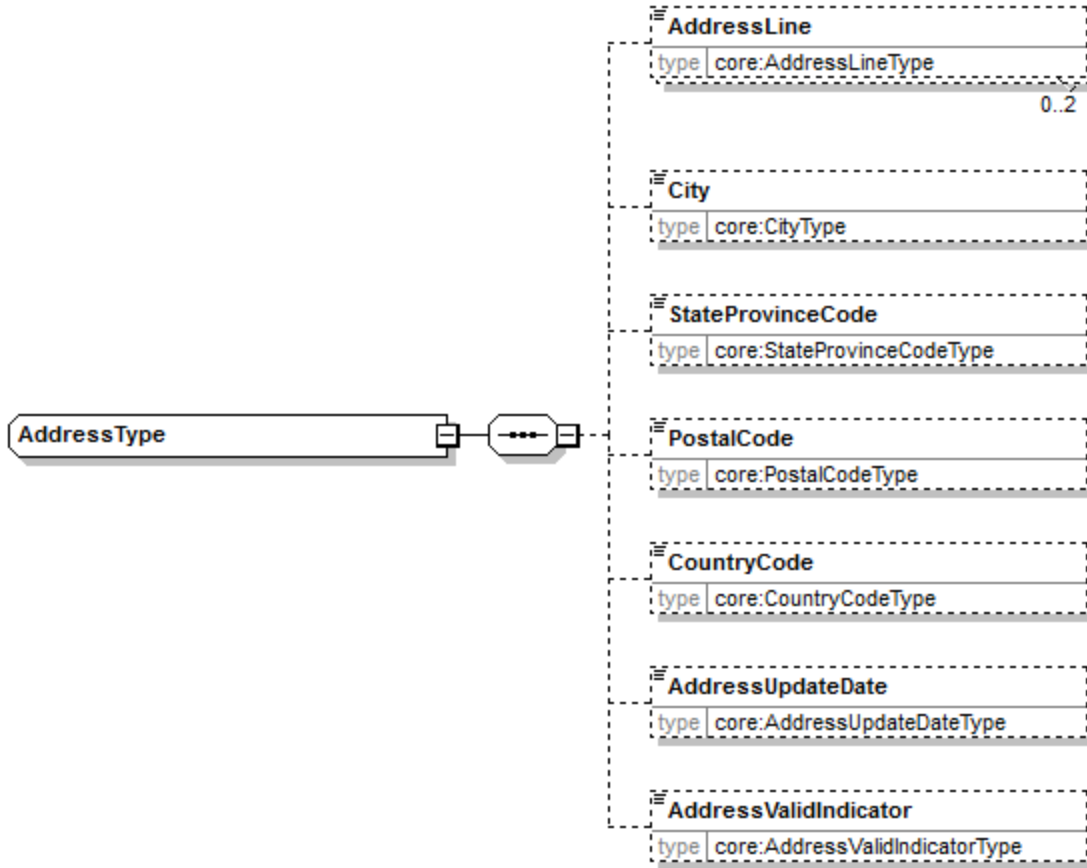

Tag name	Usage	Description	Format
AddressLine	Optional	Sequenced lines of student's street address	Xs: string minOcc 0 maxOcc 2 maxLength 40
City	Optional	City where student lives	Xs: string minOcc 0 maxOcc 1
StateProvinceCode	Optional	State or province where student lives	Enumeration: <i>see Appendix A for values</i> minOcc 0 maxOcc 1
PostalCode	Optional	Postal code where student lives	Xs: string minOcc 0 maxOcc 1 maxLength 17
CountryCode	Optional	Country where student lives	Enumeration: <i>see Appendix B for values</i> minOcc 0 maxOcc 1
AddressUpdateDate	Optional	Date the student's address became effective	Xs: date ccyy-mm-dd minOcc 0 maxOcc 1
AddressValidIndicator	Optional	Flag to indicate that the student's address is valid	Xs: boolean minOcc 0 maxOcc 1

NSLDSEnroll:AttendedSchoolType

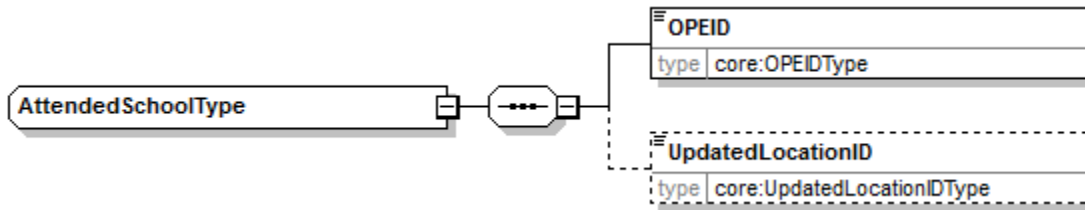

Tag name	Usage	Description	Format
OPEID	Required	The unique identifier assigned by the Office of Postsecondary Education for each data exchange partner	Xs: string minOcc 1 maxOcc 1 minLength 8 maxLength 8
UpdatedLocationID	Optional	School location identification code where the student enrollment should be certified. <i>Action associated with this code will be a withdrawal from the original location code specified as part of the OPEID and an add/update to the new location code using the reported detail.</i>	minOcc 0 maxOcc 1 minLength 2 maxLength 2

NSLDSEnroll:NSLDSEnrollmentDataType

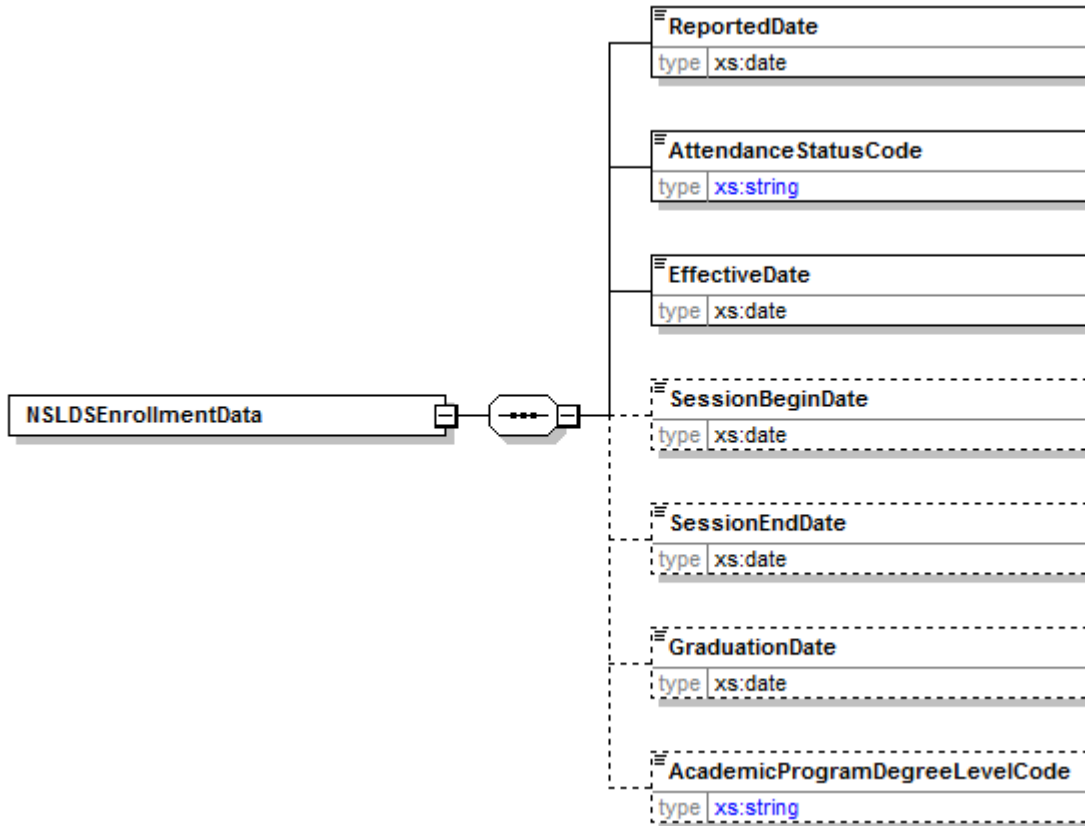

Tag name	Usage	Description	Format
ReportedDate	Required	The date the student's current enrollment status was certified by school	Xs: date ccyy-mm-dd minOcc 1 maxOcc 1
AttendanceStatusCode	Required	Student's enrollment status at the school	Enumeration: - <i>ApprovedLeaveOfAbsence</i> (flat file value = A) - <i>Deceased</i> (flat file value = D) - <i>FullTime</i> (flat file value = F) - <i>Graduated</i> (flat file value = G) - <i>HalfTime</i> (flat file value = H) - <i>LessThanHalfTime</i> (flat file value = L) - <i>Withdrawn</i> (flat file value = W) - <i>NeverAttended</i> (flat file value = X) - <i>NoRecordFound</i> (flat file value = Z) <i>see Appendix C for more information about enumerated values</i> minOcc 1 maxOcc 1
EffectiveDate	Required	The date the student's current enrollment status took effect	Xs: date ccyy-mm-dd minOcc 1 maxOcc 1
SessionBeginDate	Optional	The date on which the current term/session began	Xs: date ccyy-mm-dd minOcc 0 maxOcc 1
SessionEndDate	Optional	The date on which the current term/session ended	Xs: date ccyy-mm-dd minOcc 0 maxOcc 1
GraduationDate	Optional/ Conditional	The student's anticipated date of graduation or termination. Required when AttendanceStatusCode is equal to ApprovedLeaveOfAbsence, FullTime, HalfTime, or LessThanHalfTime	Xs: date ccyy-mm-dd minOcc 0 maxOcc 1

Tag name	Usage	Description	Format
AcademicProgramDegreeLevelCode	Optional/ Conditional	The student's academic credential level at the time of graduation – should be provided for AttendanceStatusCode value of Graduated	Enumeration - <i>UndergraduateCertificate</i> - <i>PostBaccalaureateCertificate</i> - <i>AssociateDegree</i> - <i>BaccalaureateDegree</i> - <i>Certificate</i> - <i>Doctorate</i> - <i>GraduateDegree</i> - <i>HighSchool</i> - <i>MastersDegree</i> - <i>NonDegree</i> - <i>PostsecondaryDiploma</i> - <i>ProfessionalDegree</i> minOcc 0 maxOcc 1

NSLDSEnroll:ResponseType



Tag name	Usage	Description	Format
EditProcessResult	Optional	A logical grouping of components used to respond application/business level edits to an inbound request. See EditProcessResult .	Aggregate minOcc 0 maxOcc 1

EditProcessResult

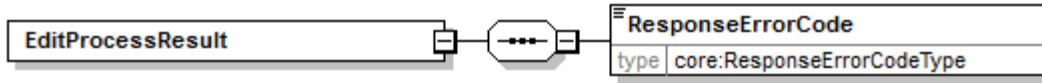

Tag name	Usage	Description	Format
ResponseErrorCode	Optional	The basic component that specifies the edit result from processing. In this case, the error code(s) that are determined to exist during file processing. Values shorter than length of 3 should be prefixed by leading zeroes.	Enumerated: <i>see Appendix D for values</i> minOcc 0 maxOcc 5 minLength 3 maxLength 3

3. XML Schema

```
<?xml version="1.0" encoding="UTF-8"?>
```

```
<xs:schema xmlns:NSLDSEnroll="us:gov:ed:fsa:nslds:enrollment:v1.0.0" xmlns:xs="http://www.w3.org/2001/XMLSchema"
xmlns:core="urn:org:pesc:core:CoreMain:v1.11.0" targetNamespace="us:gov:ed:fsa:nslds:enrollment:v1.0.0"
elementFormDefault="unqualified" attributeFormDefault="unqualified">
```

```
  <xs:import namespace="urn:org:pesc:core:CoreMain:v1.11.0" schemaLocation="CoreMain_v1.11.0.xsd"/>
```

```
  <!--=====-->
```

```
  <!--=====-->
```

```
  <!--Name:   NSLDSEnrollmentRecord.xsd-->
```

```
  <!--Version: 1.0.0-->
```

```
  <!--Date:   06-January-2012-->
```

```
  <!------>
```

```
  <!--ChangeCode Log:-->
```

```
  <!--v1.0.0 06-January-2012 Jeffrey Funck - -->
```

```
  <!--Creation of NSLDS Enrollment Reporting Schema - Initial schema. -->
```

```
  <!-- Change # KB20111114091400-->
```

```
  <!--=====-->
```

```
  <!--=====-->
```

```
  <xs:element name="NSLDSEnrollmentRecord">
```

```
    <xs:annotation>
```

```

        <xs:documentation> Root tag of the NSLDS Enrollment Record</xs:documentation>
    </xs:annotation>
    <xs:complexType>
        <xs:sequence>
            <xs:element name="TransmissionData" type="NSLDSEnroll:TransmissionDataType"/>
            <xs:element name="Student" type="NSLDSEnroll:StudentType" maxOccurs="unbounded"/>
            <xs:element name="TotalCount" type="core:TotalCountType"/>
        </xs:sequence>
    </xs:complexType>
</xs:element>
<!--=====-->
<!--TransmissionData Types-->
<!--=====-->
<xs:complexType name="TransmissionDataType">
    <xs:annotation>
        <xs:documentation> TransmissionData Type</xs:documentation>
    </xs:annotation>
    <xs:sequence>
        <xs:element name="FileContentID" type="core:FileContentIDType" minOccurs="0"/>
        <xs:element name="CreatedDateTime" type="core:CreatedDateTimeType"/>

```

```

        <xs:element name="DocumentTypeCode" type="core:DocumentTypeCodeType"/>
        <xs:element name="FileTypeCode" type="core:FileTypeCodeType"/>
    </xs:sequence>
</xs:complexType>
<!--=====-->
<!--PersonID Types-->
<!--=====-->
<xs:complexType name="IndexType">
    <xs:annotation>
        <xs:documentation> Person Identifier Information</xs:documentation>
    </xs:annotation>
    <xs:sequence>
        <xs:element name="SSN">
            <xs:simpleType>
                <xs:restriction base="core:SSNType">
                    <xs:maxLength value="9"/>
                </xs:restriction>
            </xs:simpleType>
        </xs:element>
        <xs:element name="BirthDate" type="core:BirthDateType"/>
    </xs:sequence>
</xs:complexType>

```

```

        <xs:element name="LastName" type="core:LastNameType"/>
    </xs:sequence>
</xs:complexType>
<xs:complexType name="StudentType">
    <xs:annotation>
        <xs:documentation> Definition of the Student Complex element</xs:documentation>
    </xs:annotation>
    <xs:sequence>
        <xs:element name="Index" type="NSLDSEnroll:IndexType"/>
        <xs:element name="RealSSNCode" type="core:RealSSNCodeType"/>
        <xs:element name="FirstName" type="core:FirstNameType"/>
        <xs:element name="MiddleName" type="core:MiddleNameType" minOccurs="0"/>
        <xs:element name="SchoolAssignedPersonID" type="core:SchoolAssignedPersonIDType" minOccurs="0"/>
        <xs:element name="Address" type="NSLDSEnroll:AddressType" minOccurs="0"/>
        <xs:element name="AttendedSchool" type="NSLDSEnroll:AttendedSchoolType"/>
        <xs:element name="NSLDSEnrollmentData" type="NSLDSEnroll:NSLDSEnrollmentDataType"/>
        <xs:element name="Response" type="NSLDSEnroll:ResponseType" minOccurs="0"/>
    </xs:sequence>
</xs:complexType>
<xs:complexType name="AddressType">

```

```

<xs:sequence>
  <xs:element name="AddressLine" type="core:AddressLineType" minOccurs="0" maxOccurs="2"/>
  <xs:element name="City" type="core:CityType" minOccurs="0"/>
  <xs:element name="StateProvinceCode" type="core:StateProvinceCodeType" minOccurs="0"/>
  <xs:element name="PostalCode" type="core:PostalCodeType" minOccurs="0"/>
  <xs:element name="CountryCode" type="core:CountryCodeType" minOccurs="0"/>
  <xs:element name="AddressUpdateDate" type="core:AddressUpdateDateType" minOccurs="0"/>
  <xs:element name="AddressValidIndicator" type="core:AddressValidIndicatorType" minOccurs="0"/>
</xs:sequence>
</xs:complexType>
<!--=====-->
<!--AttendedSchool Types-->
<!--=====-->
<xs:complexType name="AttendedSchoolType">
  <xs:sequence>
    <xs:element name="OPEID" type="core:OPEIDType"/>
    <xs:element name="UpdatedLocationID" type="core:UpdatedLocationIDType" minOccurs="0"/>
  </xs:sequence>
</xs:complexType>

```

```

<!--=====-->
<!--NSLDS Reporting Types-->
<!--=====-->
<xs:complexType name="NSLDSEnrollmentDataType">
  <xs:annotation>
    <xs:documentation> Definition of the Enrollment Data Complex element</xs:documentation>
  </xs:annotation>
  <xs:sequence>
    <xs:element name="ReportedDate" type="core:ReportedDateType"/>
    <xs:element name="AttendanceStatusCode" type="core:AttendanceStatusCodeType"/>
    <xs:element name="EffectiveDate" type="core:EffectiveDateType"/>
    <xs:element name="SessionBeginDate" type="core:SessionBeginDateType" minOccurs="0"/>
    <xs:element name="SessionEndDate" type="core:SessionEndDateType" minOccurs="0"/>
    <xs:element name="GraduationDate" type="core:GraduationDateType" minOccurs="0"/>
    <xs:element name="AcademicProgramDegreeLevelCode" type="core:AcademicProgramDegreeLevelCodeType" minOccurs="0"/>
  </xs:sequence>
</xs:complexType>
<xs:complexType name="ResponseType">
  <xs:sequence>
    <xs:element name="EditProcessResult">

```

```
<xs:complexType>
  <xs:sequence>
    <xs:element name="ResponseErrorCode" type="core:ResponseErrorCodeType"/>
  </xs:sequence>
</xs:complexType>
</xs:element>
</xs:sequence>
</xs:complexType>
<!--=====-->
</xs:schema>
```

Appendix A - <StateProvinceCode> Tag Enumeration Values

StateProvinceCode	Description
AL	Alabama
AK	Alaska
AZ	Arizona
AR	Arkansas
CA	California
CO	Colorado
CT	Connecticut
DE	Delaware
DC	District of Columbia*
FL	Florida
GA	Georgia
HI	Hawaii
ID	Idaho
IL	Illinois
IN	Indiana
IA	Iowa
KS	Kansas
KY	Kentucky
LA	Louisiana
ME	Maine
MD	Maryland
MA	Massachusetts
MI	Michigan
MN	Minnesota
MS	Mississippi
MO	Missouri
MT	Montana
NE	Nebraska
NV	Nevada
NH	New Hampshire
NJ	New Jersey
NM	New Mexico
NY	New York
NC	North Carolina

StateProvinceCode	Description
ND	North Dakota
OH	Ohio
OK	Oklahoma
OR	Oregon
PA	Pennsylvania
RI	Rhode Island
SC	South Carolina
SD	South Dakota
TN	Tennessee
TX	Texas
UT	Utah
VT	Vermont
VA	Virginia
WA	Washington
WV	West Virginia
WI	Wisconsin
WY	Wyoming
AB	Alberta
BC	British Columbia
MB	Manitoba
NB	New Brunswick
NL	Newfoundland and Labrador
NT	Northwest Territories
NS	Nova Scotia
NU	Nunavut
ON	Ontario
PE	Prince Edward Island
QC	Quebec
SK	Saskatchewan
YT	Yukon

Appendix B - <CountryCode> Tag Enumeration Values

Country Code	Description
AF	Afghanistan
AL	Albania
DZ	Algeria
AO	Angola
AG	Antigua and Barbuda
AR	Argentina
AM	Armenia
AU	Australia
NF	Norfolk Island
AT	Austria
AZ	Azerbaijan
BS	Bahamas
BH	Bahrain
BD	Bangladesh
BB	Barbados
BY	Belarus
BE	Belgium
BZ	Belize
BJ	Benin
BT	Bhutan
BO	Bolivia
BA	Bosnia and Herzegovina
BW	Botswana
BR	Brazil
BN	Brunei Darussalam
BG	Bulgaria (Republic)
BF	Burkina Faso
BI	Burundi
KH	Cambodia
CM	Cameroon
CA	Canada
CV	Cape Verde
CF	Central African Republic
TD	Chad
CL	Chile
CN	China (People's Republic)
HK	Hong Kong, China (People's Republic)
MO	Macao, China (People's Republic)
CO	Colombia

Country Code	Description
KM	Comoros
CG	Congo (Republic)
CR	Costa Rica
CI	Cote d'Ivoire (Republic)
HR	Croatia
CU	Cuba
CY	Cyprus
CZ	Czech Republic
KP	Democratic People's Republic of Korea
CD	Democratic Republic of the Congo
DK	Denmark
FO	Faroe Islands
GL	Greenland
DJ	Djibouti
DM	Dominica
DO	Dominican Republic
EC	Ecuador
EG	Egypt
SV	El Salvador
GQ	Equatorial Guinea
ER	Eritrea
EE	Estonia
ET	Ethiopia
FJ	Fiji
FI	Finland (including the ?land Islands)
FR	France
GF	French Guiana
GP	Guadeloupe (incl. St Barthelemy)
MQ	Martinique
RE	Reunion
YT	Territorial Community of Mayotte
PM	Territorial Community of St Pierre
PF	French Polynesia (including Clipperton)
TF	French Southern and Antarctic Territories
NC	New Caledonia
RE	Scattered Islands
WF	Wallis and Futuna Islands
GA	Gabon
GM	Gambia
GE	Georgia
DE	Germany
GH	Ghana
GB	Great Britain

Country Code	Description
AI	Anguilla
SH	Ascension
BM	Bermuda
IO	British Indian Ocean Territory
VG	British Virgin Islands
KY	Cayman Islands
FK	Falkland Islands (Malvinas)
GI	Gibraltar
MS	Montserrat
PN	Pitcairn, Henderson, Ducie and Oeno
GS	South Georgia and the South
SH	St Helena
SH	Tristan da Cunha
TC	Turks and Caicos Islands
GR	Greece
GD	Grenada
GT	Guatemala
GN	Guinea
GW	Guinea-Bissau
GY	Guyana
HT	Haiti
HN	Honduras (Republic)
HU	Hungary (Republic)
IS	Iceland
IN	India
ID	Indonesia
IR	Iran (Islamic Republic)
IQ	Iraq
IE	Ireland
IL	Israel
IT	Italy
JM	Jamaica
JP	Japan
JO	Jordan
KZ	Kazakhstan
KE	Kenya
KI	Kiribati
KR	Korea (Republic)
KW	Kuwait
KG	Kyrgyzstan
LA	Lao People's Democratic Republic
LV	Latvia
LB	Lebanon

Country Code	Description
LS	Lesotho
LR	Liberia
LY	Libyan Jamahiriya
LI	Liechtenstein
LT	Lithuania
LU	Luxembourg
MG	Madagascar
MW	Malawi
MY	Malaysia
MV	Maldives
ML	Mali
MT	Malta
MR	Mauritania
MU	Mauritius
MX	Mexico
MD	Moldova
MC	Monaco
MN	Mongolia
MA	Morocco
MZ	Mozambique
MM	Myanmar
NA	Namibia
NR	Nauru
NP	Nepal
NL	Netherlands
AW	Aruba
AN	Netherlands Antilles
NZ	New Zealand (including the Ross Dependency)
CK	Cook Island
NU	Niue
TK	Tokelau
NI	Nicaragua
NE	Niger
NG	Nigeria
NO	Norway
OM	Oman
PK	Pakistan
PA	Panama (Republic)
PG	Papua New Guinea
PY	Paraguay
PE	Peru
PH	Philippines
PL	Poland

Country Code	Description
PT	Portugal
QA	Qatar
RO	Romania
RU	Russian Federation
RW	Rwanda
KN	Saint Christopher (St Kitts) and Nevis
LC	Saint Lucia
VC	Saint Vincent and the Grenadines
WS	Samoa
SM	San Marino
ST	Sao Tome and Principe
SA	Saudi Arabia
SN	Senegal
YU	Serbia and Montenegro
SC	Seychelles
SL	Sierra Leone
SG	Singapore
SK	Slovakia
SI	Slovenia
SB	Solomon Islands
SO	Somalia
ZA	South Africa
ES	Spain
LK	Sri Lanka
SD	Sudan
SR	Suriname
SZ	Swaziland
SE	Sweden
CH	Switzerland
SY	Syrian Arab Republic
TJ	Tajikistan
TZ	Tanzania (United Republic)
TH	Thailand
MK	The former Yugoslav Rep of Macedonia
TG	Togo
TO	Tonga (including Niuafu'ou)
TT	Trinidad and Tobago
TN	Tunisia
TR	Turkey
TM	Turkmenistan
TV	Tuvalu
UG	Uganda
UA	Ukraine

Country Code	Description
AE	United Arab Emirates
US	United States of America
GU	Guam
PR	Puerto Rico
AS	Samoa
VI	Virgin Islands of the USA
MP	Trust territory of the Pacific Islands
UY	Uruguay
UZ	Uzbekistan
VU	Vanuatu
VA	Vatican
VE	Venezuela
VN	Viet Nam
YE	Yemen
ZM	Zambia
ZW	Zimbabwe
AD	Andorra
MH	Marshall Islands
FM	Micronesia (Federated States of)
PW	Palau
TP	East Timor
UM	United States Minor Outlying Islands

Appendix C - <AttendanceStatusCode> Tag Enumeration Values

AttendanceStatusCode Value	Flat File Code	Definition	Date Used as EffectiveDate
ApprovedLeaveOfAbsence	A	Student is currently enrolled at this institution, but has a leave of absence approved in accordance with [34 CFR 668.22(d)(2)].	Date the student began an approved leave of absence.
Deceased	D	Student is deceased.	Date of death, if known; otherwise, the date the institution was notified of the death by a reliable source.
FullTime	F	Student is enrolled full-time, according to the institution's definition, in accordance with [34 CFR 668.2] or [34 CFR 682.200].	Date on which the student most recently began uninterrupted ¹ enrollment on a full-time basis.
Graduated	G	Student has completed the course of study and is not currently admitted to, nor enrolled in, a different course of study at this institution.	Date the student completed the course requirements (not presentation date of the diploma or certificate).
HalfTime	H	Student is enrolled at least half-time, but less than full-time, according to this institution's definition, in accordance with [34 CFR 682.200].	Date student dropped below full-time, or if half time is the original status, the date on which the student most recently began uninterrupted ¹ enrollment on a half time or more, but less than full-time basis.
LessThanHalfTime	L	Student is enrolled less than half-time, according to this institution's definition, in accordance with [34 CFR 682.200].	Date student dropped below half time, or if less than half time is the original status, the date on which the student most recently began uninterrupted ¹ enrollment on a less than half-time basis.
Withdrawn	W	Student has officially withdrawn from all courses at this institution, stopped attending all classes at this institution but did not officially withdraw, or for any reason did not re-enroll at this institution for the next regular (non-summer) term without completing the course of study.	Date student officially withdraws or, in the absence of a formal withdrawal, the last recorded date of attendance. In the case of the student who completes a term and does not return for the next, leaving the course of study uncompleted, the final day of the term in which the student was last enrolled.

AttendanceStatusCode Value	Flat File Code	Definition	Date Used as EffectiveDate
NeverAttended	X	Individual on whose behalf a loan was certified or awarded, who was admitted, may have enrolled (registered), but never attended classes at this institution. (Institution <i>does</i> have a record of the individual.)	Report ReportedDate
NoRecordFound	Z	Individual for whom a thorough search of the institution's records reveals no information. (Institution <i>does not</i> have a record of the individual.)	Report ReportedDate

Appendix D - <ResponseErrorCode> Tag Enumeration Values

ResponseErrorCode	Tag Name	Error Message
011	SSN	The student identifiers (SSN, FirstName, and BirthDate) submitted by a school do not match those for any student in the database.
	FirstName	
	BirthDate	
013	BirthDate	Invalid BirthDate. Must be a valid date in CCYYMMDD format.
015	GraduationDate	Invalid GraduationDate. Must be a valid date in CCYYMMDD format when AttendanceStatusCode is equal to ApprovedLeaveOfAbsence, FullTime, HalfTime or LessThanHalfTime
016	GraduationDate	GraduationDate cannot be greater than 10 years after the ReportedDate
019	AttendanceStatusCode	Missing AttendanceStatusCode.
020	AttendanceStatusCode	Invalid AttendanceStatusCode. Valid values are ApprovedLeaveOfAbsence, Deceased, FullTime, Graduated, HalfTime, LessThanHalfTime, NeverAttended, NoRecordFound, and Withdrawn.
021	EffectiveDate	Invalid enrollment EffectiveDate. Must be a valid date in CCYYMMDD format. It must be less than 45 years in the past, based on ReportedDate (formerly based on Roster Generation), and greater than the BirthDate plus 12 years. This edit is not applied to AttendanceStatusCode values of Deceased (with default), NeverAttended or NoRecordFound
022	AttendanceStatusCode	A school cannot report an AttendanceStatusCode of NeverAttended or NoRecordFound if an enrollment history (AttendanceStatusCode of FullTime, HalfTime, LessThanHalfTime or ApprovedLeaveOfAbsence) already exists for student at that school.
023	EffectiveDate	Missing enrollment status EffectiveDate. Must be a valid date in CCYYMMDD format. This edit is not applied to AttendanceStatusCode value of Deceased, NeverAttended, or NoRecordFound
026	GraduationDate	GraduationDate must be greater than ReportedDate when school reports AttendanceStatusCode of ApprovedLeaveOfAbsence, FullTime, HalfTime or LessThanHalfTime. NSLDS will substitute the ACD on its database when no GraduationDate is returned on the submittal file, but that ACD will still be subject to this edit.
030	EffectiveDate	Enrollment status EffectiveDate must be less than ReportedDate.

ResponseErrorCode	Tag Name	Error Message
032	EffectiveDate	Student status could not be applied as current. This is due to a school reporting an AttendanceStatusCode, EffectiveDate or GraduationDate that does not match the current value stored in the database with a new ReportedDate prior to the current ReportedDate. As of October 19, 2008, this will also apply when the enrollment code shows a difference between active attendance and inactive attendance with the same effective date, and more than one previous certification occurred at least one year prior.
033	GraduationDate	GraduationDate must be greater than or equal to enrollment status EffectiveDate when AttendanceStatusCode is equal to ApprovedLeaveOfAbsence, FullTime, HalfTime or LessThanHalfTime
	EffectiveDate	
034	ReportedDate	AttendanceStatusCode is equal to ApprovedLeaveOfAbsence, FullTime, HalfTime or LessThanHalfTime and has not changed since the last submission; enrollment status Effective Date cannot equal ReportedDate.
	EffectiveDate	
035	AttendanceStatusCode	ReportedDate cannot be more than 180 days after enrollment status EffectiveDate for AttendanceStatusCode equal to ApprovedLeaveOfAbsence
036	EffectiveDate	If a school has 10 or more students on its previous Enrollment Reporting roster file and more than 10 percent of the records on a submittal file have an AttendanceStatusCode of Deceased, Roster Receipt will reject all the detail records that contain that status.
037	ReportedDate	Invalid ReportedDate. Must be a valid date in CCYYMMDD format.
038	ReportedDate	The ReportedDate has preceded the earliest allowable date for certification of data. This date is controlled by a validation parameter and is calculated by subtracting the number of parameter days from the current date.
039	ReportedDate	The ReportedDate is in the future. Future certification of data is not allowed.