



**NONRESIDENT  
TRAINING  
COURSE**



September 1996

---

# **Electronics Technician**

## **Volume 8—Support Systems**

**NAVEDTRA 14093**

**Although the words “he,” “him,” and “his” are used sparingly in this course to enhance communication, they are not intended to be gender driven or to affront or discriminate against anyone.**

## PREFACE

By enrolling in this self-study course, you have demonstrated a desire to improve yourself and the Navy. Remember, however, this self-study course is only one part of the total Navy training program. Practical experience, schools, selected reading, and your desire to succeed are also necessary to successfully round out a fully meaningful training program.

**COURSE OVERVIEW:** In completing this nonresident training course, you should be able to: describe the different liquid cooling systems, dry air systems, ac power distribution systems, ship's input systems in terms of their different types, component parts, configuration, operation, and maintenance.

**THE COURSE:** This self-study course is organized into subject matter areas, each containing learning objectives to help you determine what you should learn along with text and illustrations to help you understand the information. The subject matter reflects day-to-day requirements and experiences of personnel in the rating or skill area. It also reflects guidance provided by Enlisted Community Managers (ECMs) and other senior personnel, technical references, instructions, etc., and either the occupational or naval standards, which are listed in the *Manual of Navy Enlisted Manpower Personnel Classifications and Occupational Standards*, NAVPERS 18068.

**THE QUESTIONS:** The questions that appear in this course are designed to help you understand the material in the text.

**VALUE:** In completing this course, you will improve your military and professional knowledge. Importantly, it can also help you study for the Navy-wide advancement in rate examination. If you are studying and discover a reference in the text to another publication for further information, look it up.

*1996 Edition Prepared by  
ETC Richard E. Hippey Jr.*

Published by  
NAVAL EDUCATION AND TRAINING  
PROFESSIONAL DEVELOPMENT  
AND TECHNOLOGY CENTER

**NAVSUP Logistics Tracking Number  
0504-LP-026-7590**

## **Sailor's Creed**

“I am a United States Sailor.

I will support and defend the Constitution of the United States of America and I will obey the orders of those appointed over me.

I represent the fighting spirit of the Navy and those who have gone before me to defend freedom and democracy around the world.

I proudly serve my country's Navy combat team with honor, courage and commitment.

I am committed to excellence and the fair treatment of all.”

# CONTENTS

Chapter	Page
1. Liquid Cooling . . . . .	1-1
2. Dry Air Systems . . . . .	2-1
3. AC Power Distribution Systems . . . . .	3-1
4. Ship's Input Systems . . . . .	4-1
5. Information Transfer Systems . . . . .	5-1
<b>Appendix</b>	
I. Glossary . . . . .	AI-1
II. References . . . . .	AII-1
INDEX . . . . .	Index-1

# SUMMARY OF THE ELECTRONICS TECHNICIAN TRAINING SERIES

This series of training manuals was developed to replace the *Electronics Technician 3 & 2* TRAMAN. The content is directed to personnel working toward advancement to Electronics Technician Second Class.

The nine volumes in the series are based on major topic areas with which the ET2 should be familiar. Volume 1, *Safety*, provides an introduction to general safety as it relates to the ET rating. It also provides both general and specific information on electronic tag-out procedures, man-aloft procedures, hazardous materials (i.e., solvents, batteries, and vacuum tubes), and radiation hazards. Volume 2, *Administration*, discusses COSAL updates, 3-M documentation, supply paperwork, and other associated administrative topics. Volume 3, *Communication Systems*, provides a basic introduction to shipboard and shore-based communication systems. Systems covered include man-pat radios (i.e., PRC-104, PSC-3) in the hf, vhf, uhf, SATCOM, and shf ranges. Also provided is an introduction to the Communications Link Interoperability System (CLIPS). Volume 4, *Radar Systems*, is a basic introduction to air search, surface search, ground controlled approach, and carrier controlled approach radar systems. Volume 5, *Navigation Systems*, is a basic introduction to navigation systems, such as OMEGA, SATNAV, TACAN, and man-pat systems. Volume 6, *Digital Data Systems*, is a basic introduction to digital data systems and includes discussions about SNAP II, laptop computers, and desktop computers. Volume 7, *Antennas and Wave Propagation*, is an introduction to wave propagation, as it pertains to Electronics Technicians, and shipboard and shore-based antennas. Volume 8, *Support System*, discusses system interfaces, sub-systems, dry air, cooling, and power systems. Volume 9, *Electro-Optics*, is an introduction to night vision equipment, lasers, thermal imaging, and fiber optics.

# INSTRUCTIONS FOR TAKING THE COURSE

## ASSIGNMENTS

The text pages that you are to study are listed at the beginning of each assignment. Study these pages carefully before attempting to answer the questions. Pay close attention to tables and illustrations and read the learning objectives. The learning objectives state what you should be able to do after studying the material. Answering the questions correctly helps you accomplish the objectives.

## SELECTING YOUR ANSWERS

Read each question carefully, then select the BEST answer. You may refer freely to the text. The answers must be the result of your own work and decisions. You are prohibited from referring to or copying the answers of others and from giving answers to anyone else taking the course.

## SUBMITTING YOUR ASSIGNMENTS

To have your assignments graded, you must be enrolled in the course with the Nonresident Training Course Administration Branch at the Naval Education and Training Professional Development and Technology Center (NETPDTC). Following enrollment, there are two ways of having your assignments graded: (1) use the Internet to submit your assignments as you complete them, or (2) send all the assignments at one time by mail to NETPDTC.

**Grading on the Internet:** Advantages to Internet grading are:

- you may submit your answers as soon as you complete an assignment, and
- you get your results faster; usually by the next working day (approximately 24 hours).

In addition to receiving grade results for each assignment, you will receive course completion confirmation once you have completed all the

assignments. To submit your assignment answers via the Internet, go to:

**<http://courses.cnet.navy.mil>**

**Grading by Mail:** When you submit answer sheets by mail, send all of your assignments at one time. Do NOT submit individual answer sheets for grading. Mail all of your assignments in an envelope, which you either provide yourself or obtain from your nearest Educational Services Officer (ESO). Submit answer sheets to:

COMMANDING OFFICER  
NETPDTC N331  
6490 SAUFLEY FIELD ROAD  
PENSACOLA FL 32559-5000

**Answer Sheets:** All courses include one “scannable” answer sheet for each assignment. These answer sheets are preprinted with your SSN, name, assignment number, and course number. Explanations for completing the answer sheets are on the answer sheet.

**Do not use answer sheet reproductions:** Use only the original answer sheets that we provide—reproductions will not work with our scanning equipment and cannot be processed.

Follow the instructions for marking your answers on the answer sheet. Be sure that blocks 1, 2, and 3 are filled in correctly. This information is necessary for your course to be properly processed and for you to receive credit for your work.

## COMPLETION TIME

Courses must be completed within 12 months from the date of enrollment. This includes time required to resubmit failed assignments.

## **PASS/FAIL ASSIGNMENT PROCEDURES**

If your overall course score is 3.2 or higher, you will pass the course and will not be required to resubmit assignments. Once your assignments have been graded you will receive course completion confirmation.

If you receive less than a 3.2 on any assignment and your overall course score is below 3.2, you will be given the opportunity to resubmit failed assignments. **You may resubmit failed assignments only once.** Internet students will receive notification when they have failed an assignment--they may then resubmit failed assignments on the web site. Internet students may view and print results for failed assignments from the web site. Students who submit by mail will receive a failing result letter and a new answer sheet for resubmission of each failed assignment.

## **COMPLETION CONFIRMATION**

After successfully completing this course, you will receive a letter of completion.

## **ERRATA**

Errata are used to correct minor errors or delete obsolete information in a course. Errata may also be used to provide instructions to the student. If a course has an errata, it will be included as the first page(s) after the front cover. Errata for all courses can be accessed and viewed/downloaded at:

<http://www.advancement.cnet.navy.mil>

## **STUDENT FEEDBACK QUESTIONS**

We value your suggestions, questions, and criticisms on our courses. If you would like to communicate with us regarding this course, we encourage you, if possible, to use e-mail. If you write or fax, please use a copy of the Student Comment form that follows this page.

## **For subject matter questions:**

E-mail: n315.products@cnet.navy.mil  
Phone: Comm: (850) 452-1001, Ext. 1713  
DSN: 922-1001, Ext. 1713  
FAX: (850) 452-1370  
(Do not fax answer sheets.)  
Address: COMMANDING OFFICER  
NETPDTC N315  
6490 SAUFLEY FIELD ROAD  
PENSACOLA FL 32509-5237

## **For enrollment, shipping, grading, or completion letter questions**

E-mail: fleetservices@cnet.navy.mil  
Phone: Toll Free: 877-264-8583  
Comm: (850) 452-1511/1181/1859  
DSN: 922-1511/1181/1859  
FAX: (850) 452-1370  
(Do not fax answer sheets.)  
Address: COMMANDING OFFICER  
NETPDTC N331  
6490 SAUFLEY FIELD ROAD  
PENSACOLA FL 32559-5000

## **NAVAL RESERVE RETIREMENT CREDIT**

If you are a member of the Naval Reserve, you may earn retirement points for successfully completing this course, if authorized under current directives governing retirement of Naval Reserve personnel. For Naval Reserve retirement, this course is evaluated at 3 points. (Refer to *Administrative Procedures for Naval Reservists on Inactive Duty*, BUPERSINST 1001.39, for more information about retirement points.)



## Student Comments

**Course Title:** Electronics Technician, Volume 8—Support Systems

**NAVEDTRA:** 14093 **Date:** \_\_\_\_\_

**We need some information about you:**

Rate/Rank and Name: \_\_\_\_\_ SSN: \_\_\_\_\_ Command/Unit \_\_\_\_\_

Street Address: \_\_\_\_\_ City: \_\_\_\_\_ State/FPO: \_\_\_\_\_ Zip \_\_\_\_\_

**Your comments, suggestions, etc.:**

<p><b>Privacy Act Statement:</b> Under authority of Title 5, USC 301, information regarding your military status is requested in processing your comments and in preparing a reply. This information will not be divulged without written authorization to anyone other than those within DOD for official use in determining performance.</p>
--

NETPDTC 1550/41 (Rev 4-00)



# CHAPTER 1

## LIQUID COOLING SYSTEMS

Liquid cooling systems are vital to the proper operation of shipboard electronic equipment. Because of their importance, these cooling systems must be reliable and readily available. Study the contents of this chapter carefully. The knowledge you acquire may one day help you prevent heat damage to a multimillion dollar piece of equipment and the loss of countless manhours being expended in its repair. Imagine how you would feel if the damage occurred because you had not checked a temperature gauge at a particular time because you were not aware of its purpose or existence. Knowledge of the equipment is one of the greatest safeguards that you can develop. Let us begin by discussing the methods for cooling electronic equipments and systems.

### ELECTRONIC EQUIPMENT COOLING METHODS

Most electronic equipment generates sufficient heat so that some form of equipment cooling is required during normal operation. Heat is generated by various parts of the equipment because electrical energy is dissipated in the form of heat whenever current flows through a resistance. This heat must be removed to prevent a change in the equipment's operating parameters and to prevent possible breakdown of electronic parts.

This section on liquid cooling systems describes some of the more common methods of heat removal from electronic equipment. It provides the basic knowledge necessary for better understanding of the major components, operation, and maintenance of a typical cooling system. Our discussion will highlight four methods of cooling: convection, forced-air, air-to-air, and air-to-liquid.

### CONVECTION COOLING

Cooling by the convection principle is shown in figure 1-1. As the heat of an equipment part warms the air in its vicinity, the warm air, being lighter, rises through the outlet openings. The cooler air is drawn in through the inlet openings to replace the warm air. This method is limited in its cooling effect because it relies

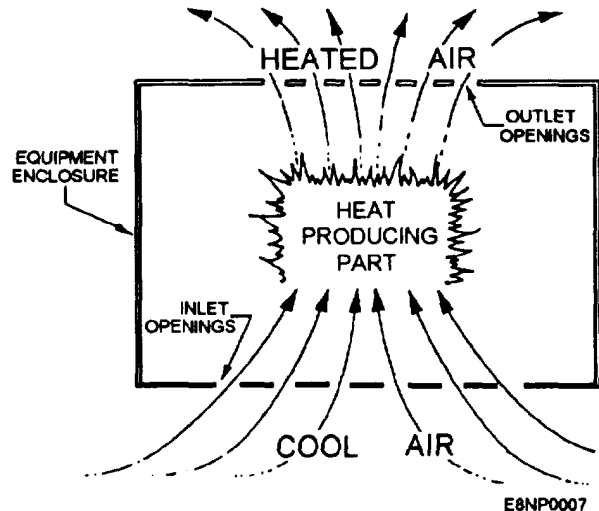


Figure 1-1.-Convection cooling.

upon the natural airflow and requires that the equipment enclosure be of open construction without air filters.

To increase heat dissipation, a finned heat sink can be added to the heat-producing part, as shown in figure 1-2. The fins increase the effective surface area of the part, allowing more heat to be transferred to the air. For the maximum transfer of heat, the part must make contact with the heat sink. Silicone grease is usually applied between the heat source and heat sink for better thermotransfer. The heat sink must be kept free of any dirt or dust, which would act as an insulator.

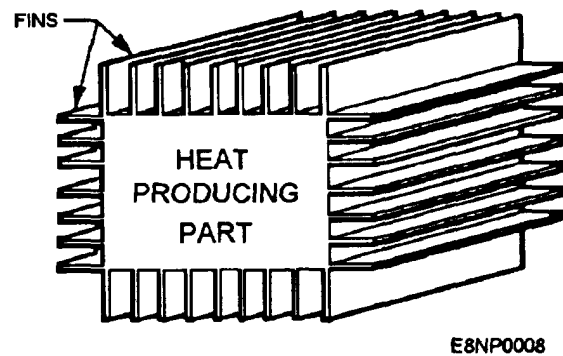


Figure 1-2.—Finned heat sink.

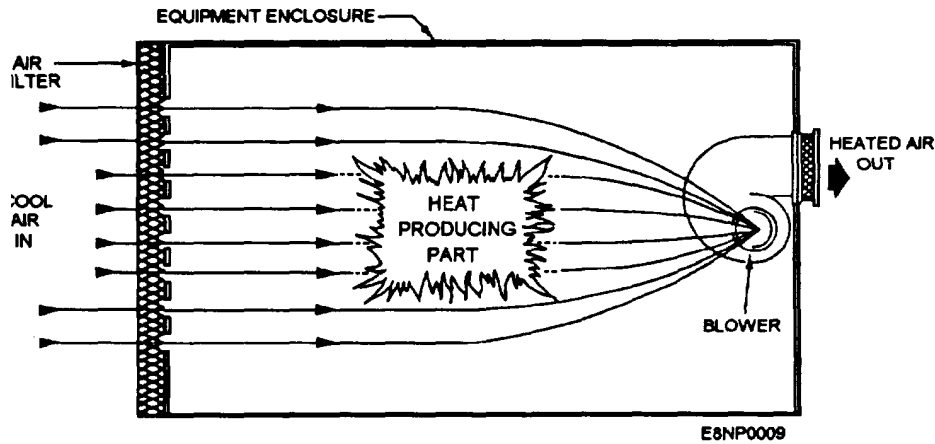


Figure 1-3.—Forced-air cooling.

**FORCED-AIR COOLING**

The increase the cooling effect over that provided by convection cooling, forced-air cooling (fig. 1-3) uses a blower to provide air movement instead of the natural convection currents. Cool air is drawn into the equipment enclosure and flows past the heat producing part, picking up the heat. The air is then exhausted out of the equipment. An air filter is provided at the air inlet to remove dust and dirt that otherwise would settle on the internal parts of the equipment. The air filter must be kept clean according to the equipment's maintenance requirements. This will ensure maximum air movement and cooling.

In some equipment, a honeycomb rf interference filter is installed on both input and outlet to prevent stray rf from entering or leaving the equipment cabinet. This filter can also collect dirt that can reduce the airflow.

Failure of a bearing in the blower motor is not an uncommon problem. A replacement of both blower

motor bearings or blower assembly is warranted at the first sign of abnormal operation, such as excessive noise or vibration. It is better to replace the bearings than to risk damage to the equipment that the blower motor is designed to protect.

**AIR-TO-AIR COOLING**

Some units of electronic equipment are hermetically sealed to prevent the entrance of moisture. For equipment of this type, an air-to-air heat exchanger (fig. 14) is used to prevent the air inside the equipment enclosure from mixing with the outside air and still allow cooling to take place. Air moving past the heat producing part absorbs heat and is forced through a heat exchanger by an internal blower. The heat in the internal air is absorbed by the heat exchanger. The cooled internal air is then returned to the equipment interior to continue the cycle.

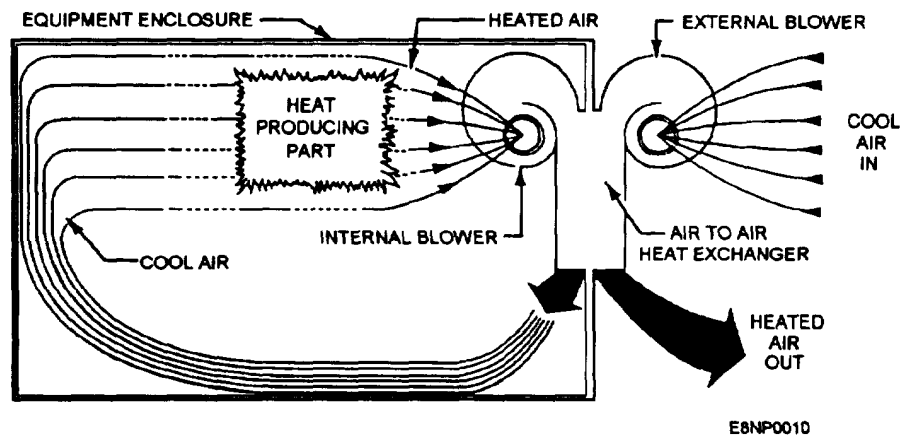


Figure 1-4.—Air-to-air cooling.

Heat is removed from the heat exchanger by forcing cool outside air through the heat exchanger by an external blower. There is no physical contact between the internal and external air. In some applications, the internal air is replaced by an inert gas such as nitrogen to prevent oxidation.

### AIR-TO-LIQUID COOLING

A more efficient heat transfer is possible by replacing the air-to-air heat exchanger with an air-to-liquid heat exchanger (fig. 1-5). In this method, the internal air is also circulated past the heat producing part and through a heat exchanger, but the heat is removed from the heat exchanger by a liquid coolant circulating through the heat exchanger.

Air-to-liquid cooling systems usually employ built-in safety devices to shut down the equipment to prevent overheating. The overheating could be caused by low or no liquid flow, liquid too hot, an inoperative circulating fan, or reduced heat exchanger efficiency because of improper maintenance.

This type of cooling system is normally found on large equipment installations where a huge amount of heat is developed. Many radar transmitters, for example, require cooling of this type. The other types that we have discussed would not be able to dissipate the heat that a high-powered radar transmitter develops. A disadvantage of this type of cooling system is that they are larger and more complex. However, for this reason and because they are a part of the more complex systems, we describe the typical liquid cooling system used aboard ship. In this way, you will be given a better understanding of the function of individual components within a system and the basic maintenance required to maintain the system to a high state of readiness.

### LIQUID COOLING

Cooling systems are essential to the satisfactory operation of all shipboard combat systems equipment. In fact, some form of cooling is required for all shipboard electronic equipment. As we have indicated, liquid cooling is especially efficient for the transfer of large amounts of heat. To maintain cooling systems, you must have a broad understanding of the different types of liquid cooling systems with which you are involved.

A typical liquid cooling system is composed of two basic coolant systems. First, there is the primary system. It provides the initial source of cooling water that can be either seawater (SW) or chilled water (CW) from the ship's air-conditioning plant, or a combination of both. Next, the secondary system transfers the heat load from the electronic equipment to the primary system. The coolant normally used in the secondary system is distilled water (DW). This distilled water is *ultrapure* and is maintained in that state by a demineralize. In some secondary systems, ethylene glycol is added to the water to prevent freezing when the system is exposed to freezing weather.

### TYPES OF LIQUID COOLING SYSTEMS

In the U.S. Navy, there are three basic configurations of liquid cooling systems, and conceivably you could be involved with all three. The type or types with which you maybe involved, depends upon the number and types of electronic equipment to be cooled. The three types of systems areas follows:

- Type I—Seawater/distilled water (SW/DW) heat exchanger with SW/DW heat exchanger standby

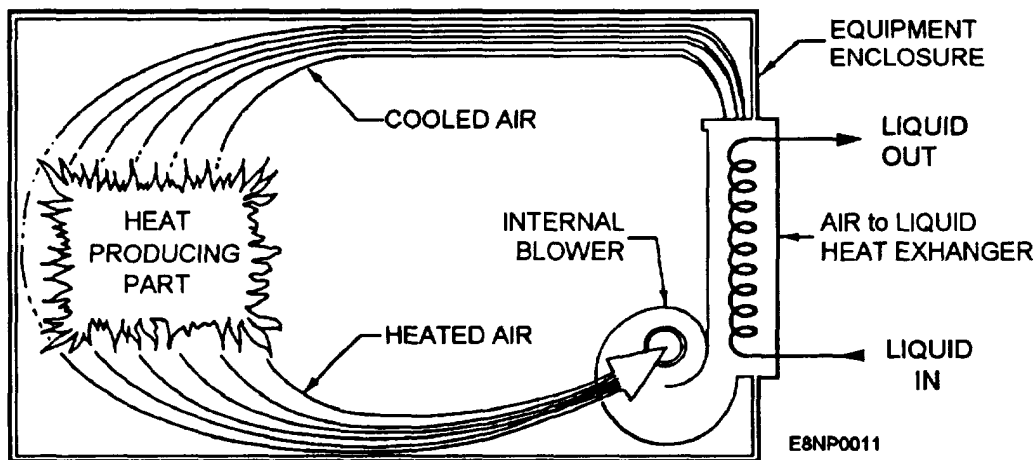


Figure 1-5.—Air-to-liquid cooling.

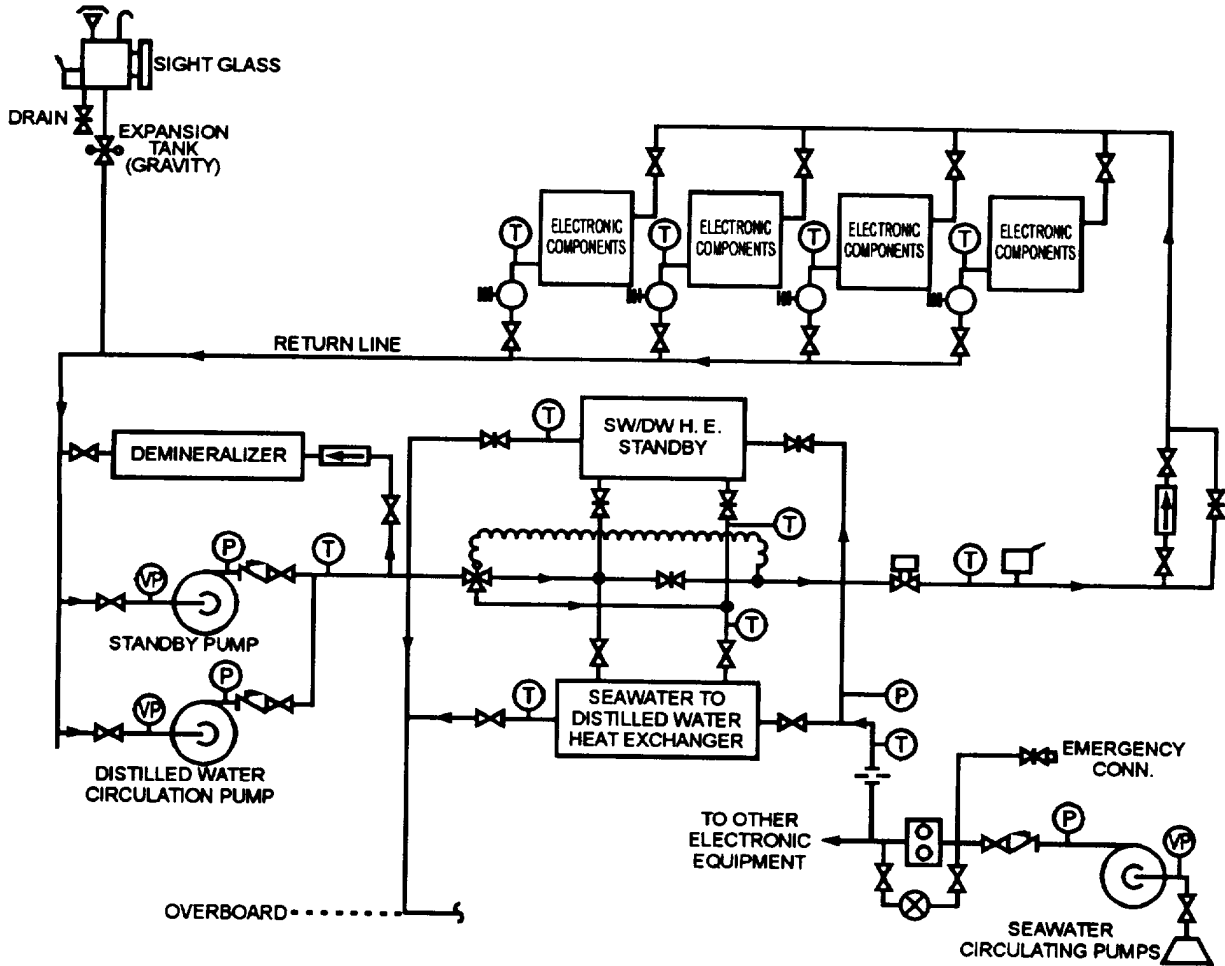
Type II—SW/DW heat exchanger with a chilled water/distilled water (CW/DW) heat exchanger standby

Type III—CW/DW heat exchanger with a CW/DW heat exchanger standby

The specifications for the type of system installed on your equipment will depend upon the operational

requirements of the equipment. Some electronic equipments require very close regulation of the temperature of the distilled water; whereas, others do not.

Type I (SW/DW) systems are used for electronic system installations that can be operated satisfactorily with seawater temperature as high as 95°F. This should



LEGEND

	OPEN VALVE		ORIFICE PLATE
	CLOSED VALVE		DUPLEX STRAINER
	2 WAY TEMP. VALVE		CONSTANT FLOW REGULATOR
	3 WAY TEMP. VALVE		DUPLEX GAUGE
	SWING CHECK VALVE		LOW FLOW SWITCH
	THERMOMETER		HIGH TEMPERATURE ALARM SWITCH
	PRESSURE GAUGE		LOCKED OPEN VALVE
	VACUUM-PRESS. GAUGE		LOW LEVEL ALARM SWITCH
	FLOWMETER		

FCNP0083

Figure 1-6.—Type I liquid cooling system.

result in a distilled water supply temperature to the electronics of approximately 104°F. Type II (SW/DW, CW/DW) systems are used in installations that cannot accept a DW temperature higher than 90°F. Type III (CW/DW) systems are used in installations where the temperature range is critical. They require close regulation of the DW coolant to maintain temperatures between established limits. For example, the temperature limits might be 70°F and 76°F. As you can see, Type III systems are used where tighter control is required.

Liquid cooling systems are composed of piping, valves, regulators, heat exchangers, strainers, circulating pumps, expansion tanks, gauges, and a demineralize. In some systems, there are specialized components to monitor cooling water to the electronic equipment. Let's examine this in greater detail by discussing the operation of the three types of liquid cooling systems. Before doing so, however, let's look at the systems in terms of primary and secondary systems.

## PRIMARY COOLING SYSTEM

The cooling water for the primary cooling system is either seawater or chilled water. The seawater, obviously, is from the sea and the chilled water is from the ship's air-conditioning plant. Figures 1-6, 1-7, and 1-8 show the basic arrangements of systems using seawater and chilled water.

In figure 1-6, seawater from a sea connection is pumped by a seawater circulating pump in one of the ship's engineering spaces through a duplex strainer to remove all debris and then through the tubes of a heat exchanger. Finally, it is discharged back into the sea at an overboard discharge. The seawater system shown in figure 1-6 is a multiple-branch system. As such, it supplies a number of heat exchangers for electronic equipment. To regulate the proper amount of seawater to each cooling system, an orifice plate is installed in the line between each heat exchanger and the duplex strainer. The heat exchangers are referred to as seawater-to-distilled-water heat exchangers.

Another means of providing seawater is through the ship's firemain, as shown in figure 1-7. The seawater is

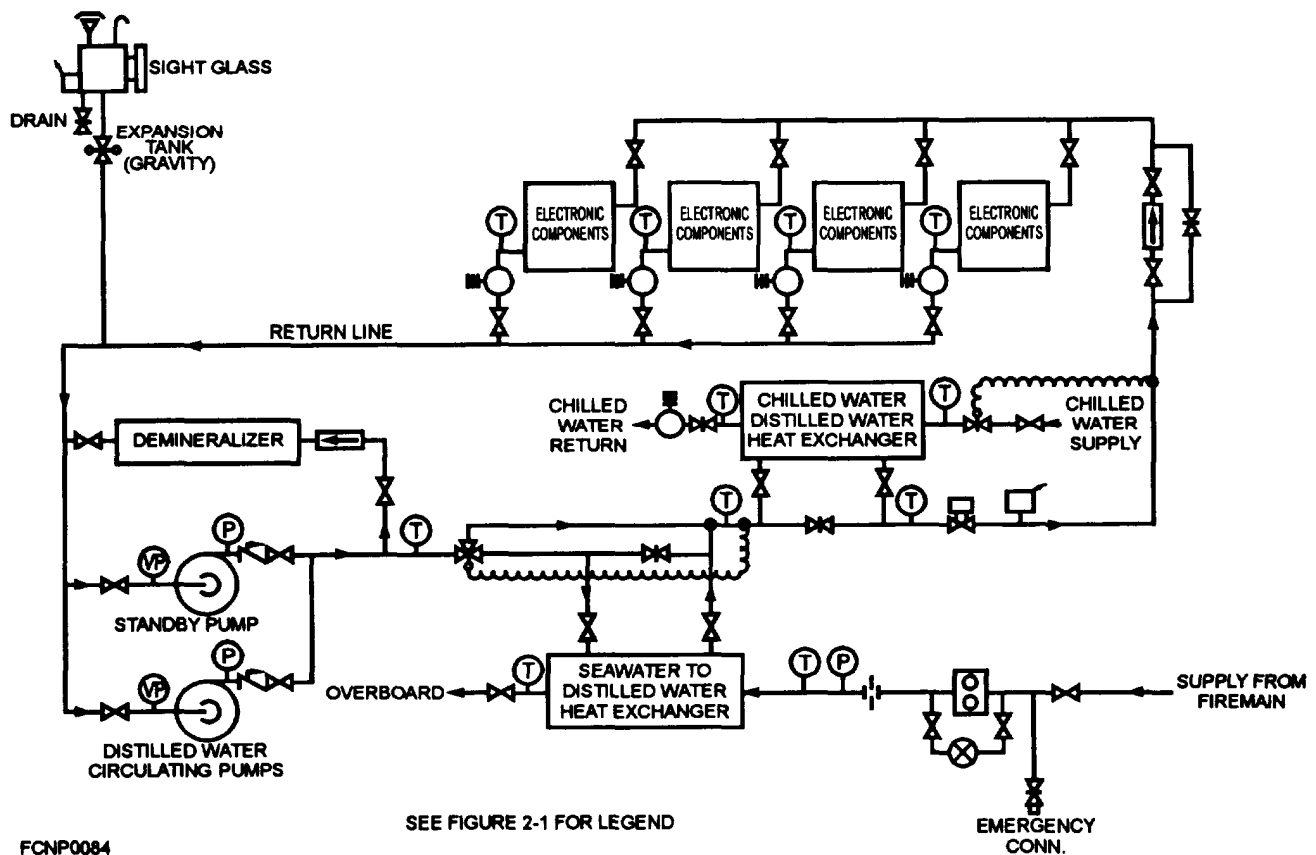


Figure 1-7.—Type II liquid cooling system.

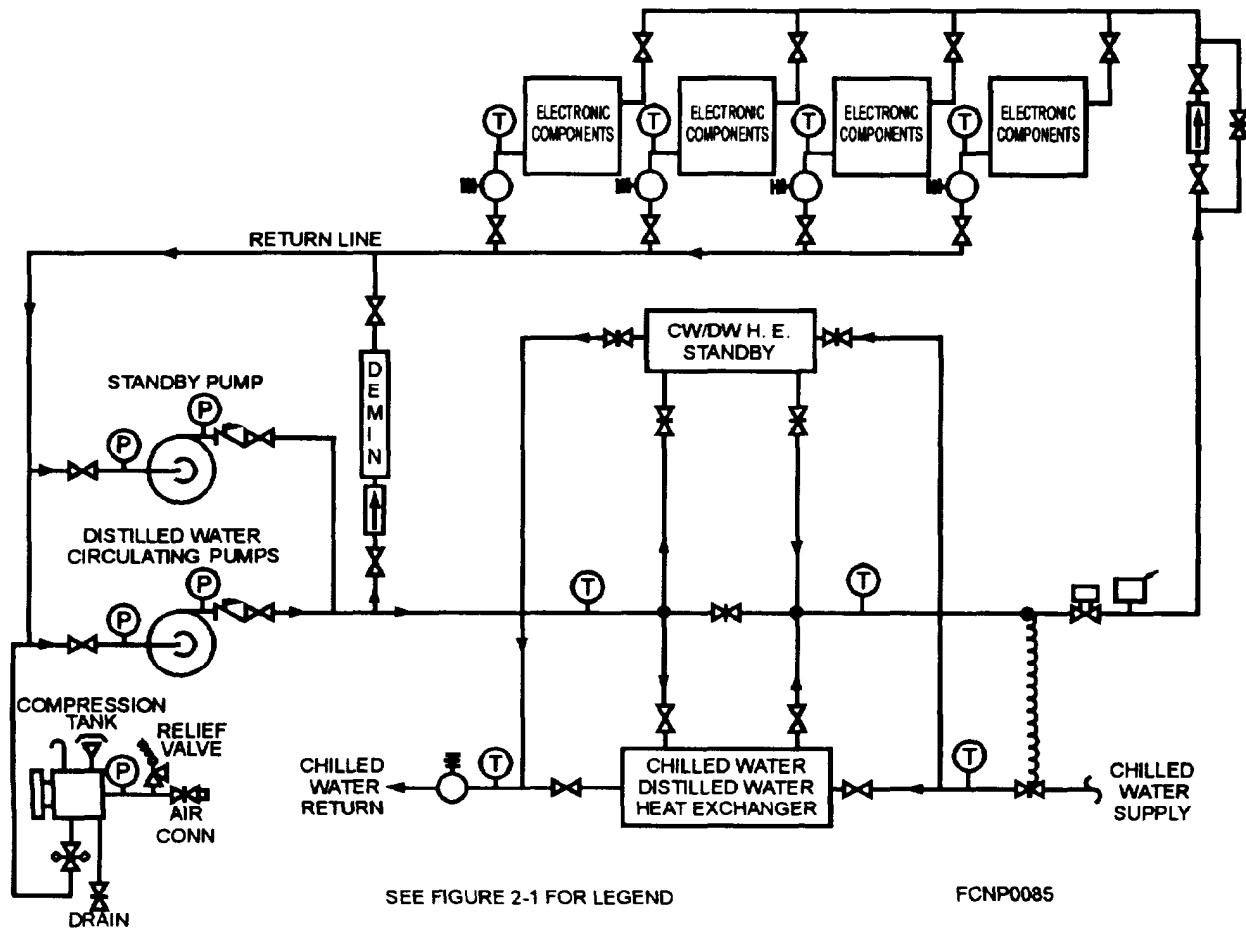


Figure 1-8.—Type III liquid cooling system.

taken from the firemain through a duplex strainer and a flow regulator (orifice plate) to and through the heat exchanger. It is then discharged overboard. The connection to the firemain is permanent.

The ship's fire pump, not shown in figure 1-7, is used to pump seawater into the firemain. The fire pump is similar in design to the previously mentioned seawater circulating pump, except it has a much larger capacity.

Another means of getting seawater as a primary coolant is by an emergency connection (figs. 1-6 and 1-7). This method is used if the normal seawater supply is lost. The connection is usually by means of a 1-inch fire hose. The emergency supply comes from an alternate portion of the ship's firemain or a portable pump rigged by the ship's damage control party. The portable emergency hose is normally stored in the liquid coolant machinery room.

Note: Seawater systems are referred to as open-looped or one-pass because the seawater flows through the system only once.

In figures 1-7 and 1-8, chilled water is taken from the supply main of the air-conditioning, chilled-water

systems. The chilled water is used as a backup source of cooling water for the primary cooling system shown in figure 1-7, and as a normal and backup source in the system shown in figure 1-8. The chilled water flows through the tubes of the heat exchanger (chilled water to distilled water), a flow regulator, and back to the chilled-water system. A temperature regulating valve at the inlet of the heat exchanger regulates the flow of chilled water through the heat exchanger to maintain the required water temperature in the secondary system (distilled water). The ship's air-conditioning, chilled-water circulating pump is used to pump the chilled water through the heat exchanger. The chilled-water system is a closed-loop water system because the water is recirculated. It must be kept tight and free from leaks to assure satisfactory operation.

## SECONDARY COOLING SYSTEM

The secondary cooling system is designed to transfer heat from the electronic equipment being cooled to the primary cooling system. This system is usually comprised of a distilled-water circulating pump, a compression or gravity-feed expansion tank, the



electronic equipment being cooled, a demineralize, a temperature control valve, monitoring equipment with its associated alarms, and the heat exchanger, which is shared with the primary system. The secondary system is a closed-loop water system, as compared to the seawater system, which is a one-pass or open-loop system.

### **TYPE I COOLING SYSTEM**

We are now ready for a more detailed look at the types of cooling systems. Let's begin by looking at the Type I system. Starting with the distilled water pumps (fig. 1-6), distilled water under pressure flows to the temperature regulating valve. The temperature regulating valve is installed to partially bypass distilled water around the seawater- to-distilled-water heat exchanger so that a constant water temperature can be supplied to the electronic equipment. As the temperature in the distilled water increases, more water is directed to the heat exchanger and less to the bypass line. This maintains the output water temperature constant. The standby heat exchanger is usually of the same design and is used when the online heat exchanger is inoperable or experiencing maintenance.

The size of the heat exchanger is designed to handle the full cooling load of the electronic equipment plus a 20 percent margin. From the heat exchanger, the water then goes through various monitoring devices, which check the water temperature and flow. These two things depend upon the requirements of the electronic equipment being coded. After the water moves through the equipment, it is drawn back to the pump on the suction side. In this way, a continuous flow of coolant is maintained in a closed-loop system.

An expansion tank is provided in the distilled water system to compensate for changes in the coolant volume, and to provide a source of makeup water in the event of a secondary system leak. When the expansion tank is located above the highest point in the secondary system and vented to the atmosphere, it is called a gravity tank. If it is below the highest point in the secondary cooling system, then it is called a compression tank, because it requires an air charge on the tank for proper operation.

The demineralize is designed to remove dissolved metals, carbon dioxide, and oxygen. In addition, a submicron filter (submicron meaning less than one millionth of a meter) is installed at the output of the demineralizer to prevent the carry-over of chemicals into the system and to remove existing solids.

### **TYPE II COOLING SYSTEM**

The secondary system of the Type II cooling system (fig. 1-7) is similar to the Type I secondary coolant system and uses many of the same components. The major difference is in the operation of the CW/DW heat exchanger. The secondary coolant is in series with the SW/DW heat exchanger and automatically supplements the cooling operation when the SW/DW heat exchanger is unable to lower the temperature of the distilled water to the normal operating temperature. The CW/DW temperature regulating valve allows more chilled water to flow in the primary cooling system to the CW/DW heat exchanger. This causes the temperature in the secondary system to go down. Normally, this action only occurs in the event of high seawater temperatures encountered in tropic waters. The CW/DW heat exchanger is also used in the event of an SW/DW heat exchanger malfunction.

### **TYPE III COOLING SYSTEM**

The Type III secondary cooling system (fig. 1-8) also operates in a similar manner to the Type I system. The major difference is in the way that the temperature of the secondary coolant is regulated. A three-way temperature regulating valve is not used. A two-way temperature regulating valve is used in the primary cooling loop to regulate the temperature of the secondary loop.

The duplicate CW/DW heat exchanger is installed parallel to the first heat exchanger and is used as a standby heat exchanger. In the event that a malfunction occurs requiring the first heat exchanger to be removed from service, the standby exchanger can be put into service by manipulating the isolation valves associated with the two heat exchangers.

## **COOLING SYSTEM COMPONENTS**

You should be able to identify and describe the operation of the individual components of a typical cooling system. This will help you to perform the required system maintenance and trouble isolation. You should never neglect the cooling system, because it will quickly deteriorate to a point where only extreme and costly maintenance will restore the system to its proper performance.

### **HEAT EXCHANGERS**

In the liquid coolant heat exchangers, heat that has been absorbed by distilled water flowing through the

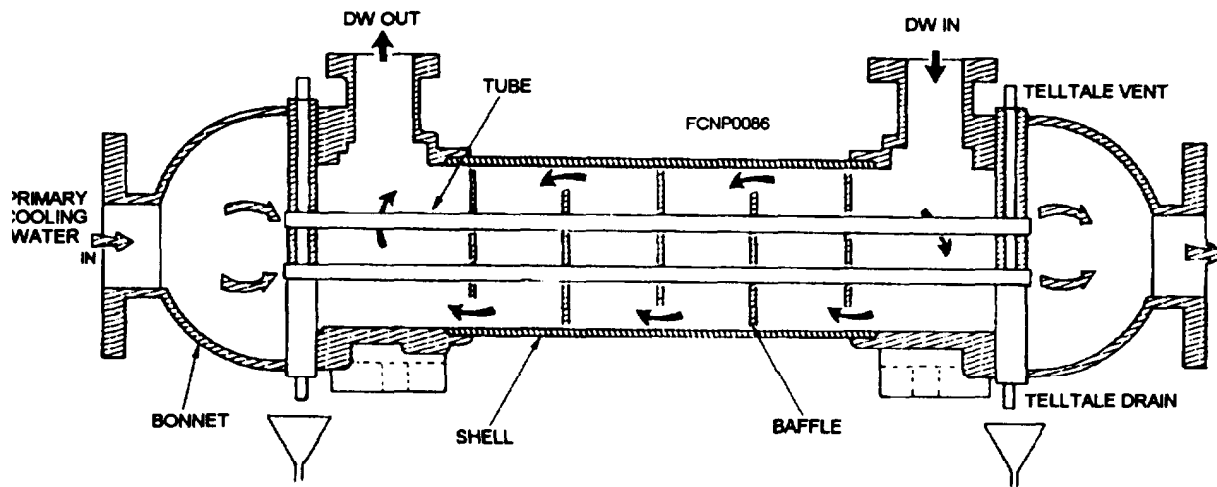


Figure 1-9.-Single-pass SW/DW heat exchanger with double-tube sheets.

electronic components is transferred to the primary cooling system, which contains either seawater or chilled water from an air-conditioning plant. In both cases (figs. 1-9 and 1-10), the heat exchangers are of the shell- and tube-type in which the secondary coolant (distilled water) flows through the shell, while the primary coolant (seawater or chilled water) flows through the tubes.

A single-pass counterflow heat exchanger (fig. 1-9) is more efficient than the double-pass heat exchanger, because there is a more uniform gradient of temperature difference between the two fluids. In figure 1-9, the primary coolant (SW/CW) flows through the tubes in the opposite direction to the flow of the secondary coolant (DW). Heat transfer occurs when the seawater flows through the tubes; extracting heat from the distilled water flowing through the shell side of the heat exchanger. The distilled water is directed by baffles to flow back and forth across the tubes as it progresses

along the inside of the shell from inlet to outlet. In figure 1-9, the preferred method of double-tube sheet construction is shown. Single-tube sheet construction is shown in figure 1-10.

Double-tube sheets are used at both ends of a tube bundle. A void space between the sheets prevents contamination of the distilled water and permits the monitoring of water loss because of tube leakage. You should be on the lookout to detect leakage at the "telltale drains," which indicates a failure of a tube joint. The type of water leaking out indicates whether the failure is in the primary or the secondary system. The telltale drains should never be plugged or capped off. A leak in one of the tubes shows up as a loss of water in the secondary side of the liquid coolant system, because it operates at a higher pressure than the primary side. This is intentional. This ensures that the distilled water is not contaminated with seawater when a leak develops in a heat exchanger.

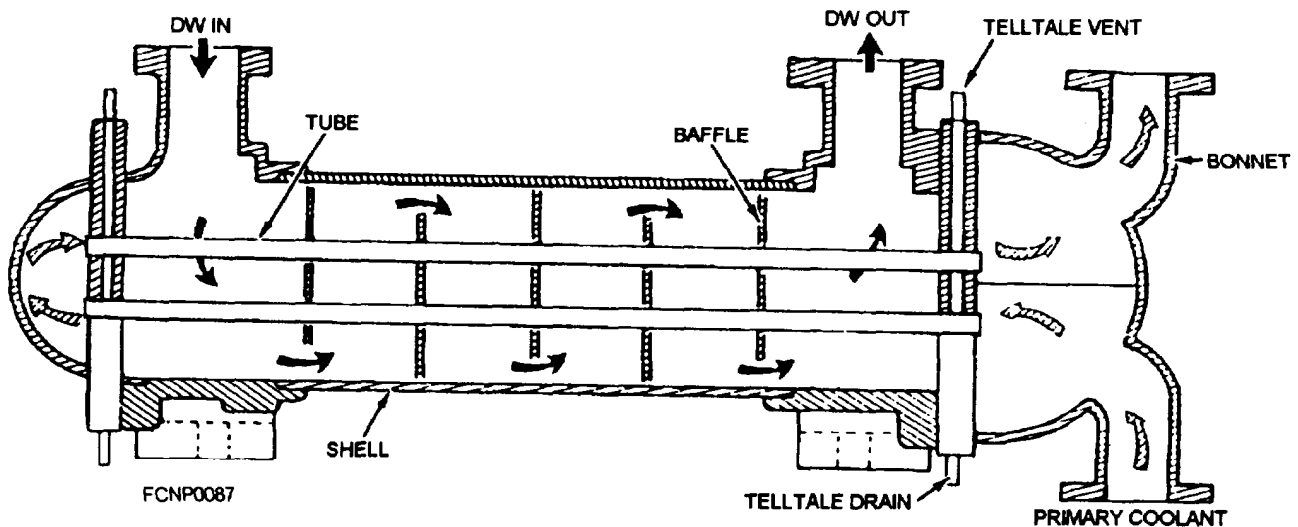


Figure 1-10.—Two-pass SW/DW heat exchanger with single-tube sheets.

A double-pass heat exchanger is generally used when there is limitation on the installation of the heat exchanger. This type of heat exchanger is less efficient than a single-pass exchanger and is subject to internal undetectable leakage across the flow divider in the inlet-outlet water box.

It is to your advantage to maintain a log on the performance of the heat exchangers installed in the cooling systems with which you are involved. By recording the operating characteristics, you will have the data you will need to later analyze the performance of the heat exchanger. The performance is monitored by observing the temperature gradient (AT) between the inlets and outlets of the two fluids. The overall effectiveness of a heat exchanger is determined by comparing its primary inlet temperature to its secondary outlet temperature. For example, with no change in the primary or secondary flow and if the heat transfer capacity of the heat exchanger drops, the AT will increase. By comparing the AT readings taken periodically with the clean heat exchanger AT readings, you can detect the deterioration of a heat exchanger because of fouling. By maintaining a record of both input and output pressure gradient ( $\Delta P$ ), you will be able to determine which side of the heat exchanger is fouled.

Heat exchangers must periodically be cleaned. The secondary section (distilled water) is cleaned by circulating chemicals through the secondary cooling system to remove any buildup of scale deposits, which accumulate on the surface of the tubes. The procedure for routine cleaning of the primary section of the heat exchanger is to first secure the sea connections to prevent flooding. In some cases, an inspection port in the water box can be opened to remove any foreign matter lodged inside and against the tubes. If you are unable to get at the ends of the heat exchanger to remove the water boxes, then you must remove the heat exchanger from its location and place it on the deck or a suitable work surface. Mark each unit removed so that it can be positioned in its proper place during reassembly. With the water boxes removed, an air lance should be passed through each tube and the passages washed out. Where severe fouling exists, a water lance should be pushed through each tube to remove foreign matter attached to the tube walls. Where *extreme* fouling exists, special cleaning equipment operated by personnel skilled in their use is required. The ship's engineering officer is the best person qualified to determine which procedure to use and whether the job can be performed aboard ship or if it must be transferred to a repair facility. You should take precautions to

ensure that tools, such as screwdrivers and wire brushes, are not used in such a way that they may scratch or mar the tube surfaces.

Over a period of time, electrolysis, which results because of dissimilar metals in the cooling system, will slowly dissolve the insides of various components in the primary seawater cooling system. (Electrolysis is not a problem in chilled water systems to the extent that it is in seawater systems.) The type of metal used in the fabrication of the heat exchanger tubes is the deciding factor as to the use of zincs anodes or zincs. Zincs are disks, rods, bars, or plates made of zinc metal that are installed inside the heat exchanger's water boxes. When zincs are installed, the electrolytic action is concentrated on the zinc and not on the metal of the heat exchanger tubes. As electrolysis dissolves the zincs instead of the heat exchanger tubes, they should be replaced. (The purity of distilled water inhibits electrolysis in the secondary system.) In an older cooling system, you should be on the lookout for thin pipes in the seawater side of the cooling system. You can check for bad pipes by gently tapping the empty pipes with the ball of a ball-peen hammer. A bad piece of pipe will make a dull sound and dimple as it is struck lightly. This work should be scheduled for overhaul while the ship is in port.

The heat exchangers in the distilled water cooling systems that cool electronic equipment are either liquid-to-air or coolant-jacket type of heat exchangers. The liquid-to-air heat exchangers are mounted inside cabinets containing the heat-producing electronic components. A cabinet fan circulates the air across the heat exchanger and to the heat source in an airtight circuit. In the coolant-jacket type of heat exchangers, the distilled water is circulated through an integral water jacket in a large heat-producing component such as a power-amplifier tube, a plate transformer, or load isolators. Vent and drain connections are provided to permit the venting of trapped air and the draining of water. Temperature gauges may be provided in the inlet and outlet piping to check the performance of the heat exchanger. Label plates indicate the water flow direction through each cabinet. Flow regulators (orifice plate or constant-flow device) usually provide a constant flow of coolant to the individual component, cabinet, or bay of electronic equipment to be cooled. On critical electronic components that would be damaged without coolant to remove the heat, coolant flow and temperature switches monitor the coolant.

## EXPANSION TANK

The expansion tank serves a threefold purpose in a liquid cooling system. First, it maintains a positive pressure required on the circulating pump inlet for proper operation of the circulating pump. Second, the expansion tank compensates for changes in the coolant volume because of temperature changes. Third, it vents air from the system and provides a source of makeup coolant to compensate for minor losses because of leakage or losses that occur during the replacement of radar equipment served by the system. The tank may be either a gravity tank or a pressurized tank.

When an expansion tank is used as a gravity tank (fig. 1-11), it is located above the highest point in the distilled water system.

This provides sufficient pressure to the suction side of the circulating pump. This also ensures a flow of water from the tank into the system when makeup water is required. The tank is provided with a sight glass to check the level of water in the tank. The sight glass should normally show the tank to be two-thirds to

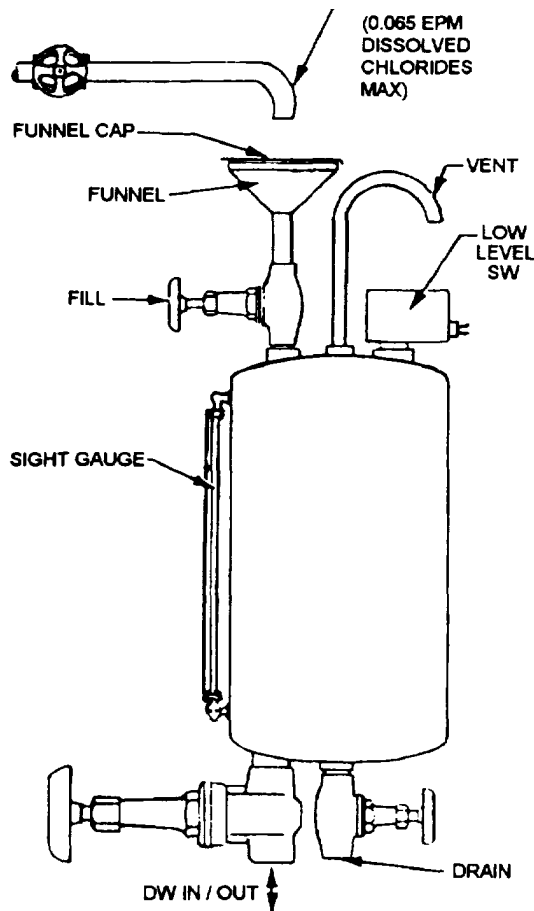


Figure 1-11.—Gravity expansion tank.

four-fifths full. The glass should be redlined at four-fifths of the tank capacity. A vent pipe is located on the top of the tank to prevent air pressure from building up in the system. A valve and funnel connection with cap is located on the top of the tank to provide a means for filling the system with distilled water. A low-level alarm switch is usually set at 20 percent of tank capacity. When the fluid level in the tank lowers to 20 percent of the full level, visual and audible alarms actuate at the alarm switchboard to warn personnel when the system is low on distilled water. If the tank should run out of water, then air is drawn into the system, which results in increased corrective maintenance on the system to remove the trapped air or possible pump damage and/or failure of high power transmitter components.

The pressurized expansion tank (fig. 1-12) is normally located near the circulating pump suction in the return main of the secondary liquid cooling system. The pressurized tank is airtight and is charged with compressed air to an appropriate pressure from the ship's low-pressure air system. In some systems, a hose

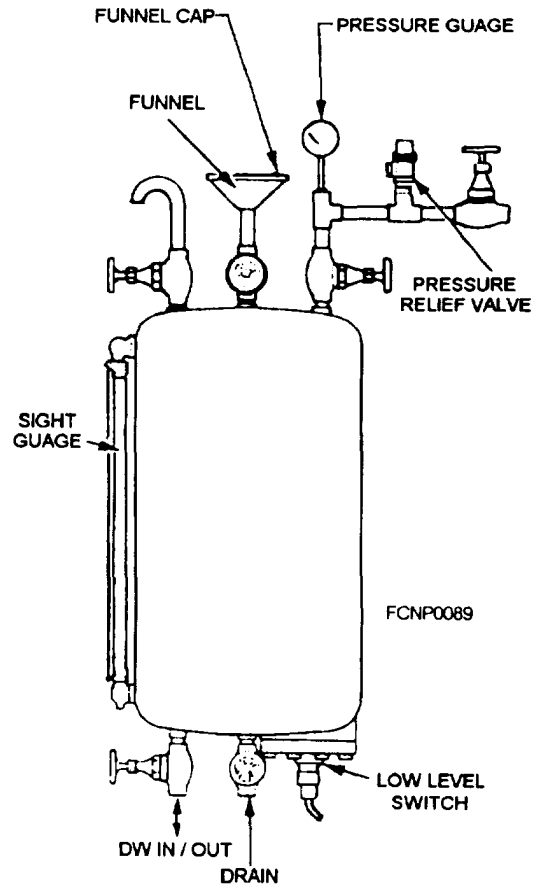


Figure 1-12.—Pre-ssure expansion tank.

is used to pressurize the tank through a quick disconnect or Schrader valve.

In other systems, a permanent pipe installation is connected to the expansion tank through a pressure-relief valve and an air shutoff valve. The ship's low-pressure air system is used to charge the pressure tank, and then it is secured to prevent a possible floodback of coolant into the low-pressure air system. The relief valve is provided to protect the tank and distilled water system from being overpressurized. The sight glass and the low-level alarm switch function the same as those on the gravity expansion tank.

In both types of expansion tanks, the bottom of the tank is connected by piping to the return main of the secondary cooling system (fig. 1-6). Changes in coolant volume causes the coolant to flow into or out of the reservoir as necessary to maintain a stable, liquid coolant, return-line pressure.

Makeup water (distilled water) is added to the expansion tank through the funnel located on the top of the tank (fig. 1-11 and 1-12). A funnel cap is provided for the funnel to prevent dirt from entering the system through the funnel. Whenever you fill the pressurized expansion tank, you have to first isolate the tank from the cooling system and the air supply, then vent the air pressure off through the vent pipe located at the top of the tank. The makeup water can be obtained directly from the ship's evaporators and preferably when the ship is making boiler feed water, because the water is double distilled. At NO time should potable (drinking) water or treated boiler feed water be used in any electronic cooling systems. After the water is drawn from the ship's evaporators, it should be transported using only a clean capped container. You should take a sample of the water from the containers and have it

tested for chloride by the ship's water test facility before any of the water is used in the cooling system. The maximum permissible level of chloride is .065 ppm (equivalent parts per million). The supply system provides an alternate source of makeup water.

The expansion-tank sight glass is your best indication of a coolant leak in the secondary cooling system. When the system uses excessive makeup water, you should inspect the whole secondary system, including the telltale drains on the heat exchanger, to locate the source of the leak. A small drip can amount to several gallons of water a day. On the pressurized expansion tank, a very small air leak indicated by a pressure drop on a tank gauge can be located by brushing on a leak detector (a thick, clear, soapy liquid such as concentrated liquid dishwasher soap) over the suspected area of the leak. The escaping air causes bubbles to form in the leak detector.

## SEAWATER STRAINERS

Strainers are used in the seawater cooling system to remove debris and sea life, which could clog the pressure and flow control device (orifice) and/or the tubes of the heat exchanger. The two types of in-line seawater strainers most commonly used in weapons cooling systems are the simplex (single) and duplex (double) basket strainers.

The simplex basket strainer (fig. 1-13) consists of a Y-pattern body housing a wire mesh basket. Some simplex strainers have a small drain on the cover to allow you to drain the water off before removing the cover. The basket is removed periodically for cleaning and inspecting for deterioration. This type of strainer requires that the seawater be secured before you clean the basket.

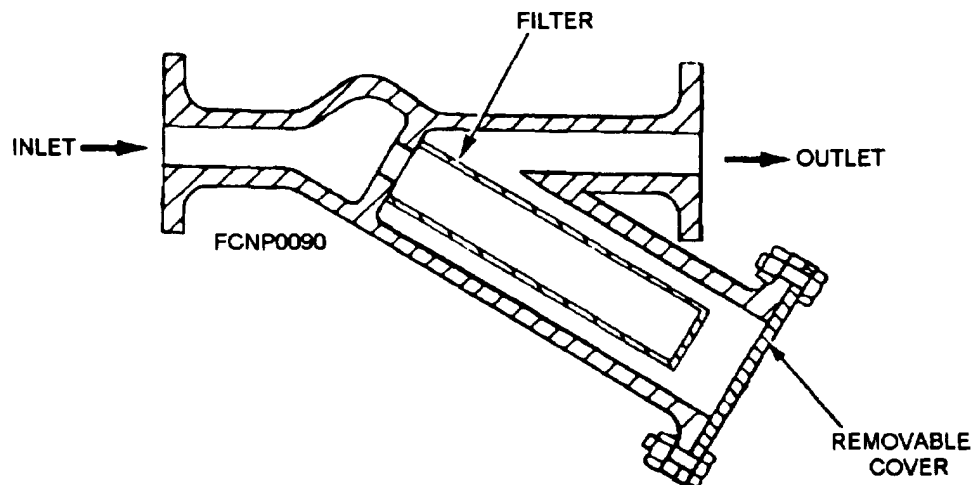


Figure 1-13.-Seawater simplex strainer.

The duplex strainer (fig. 1-14) consists of two removable baskets located in parallel at the seawater inlet. Seawater flows into the top of one basket and out through the perforated sides to the outlet. This arrangement allows maintenance to be performed on one basket while the system is in operation. A selector valve is arranged so that with the handle in one position, seawater flows through one of the baskets, leaving the other basket accessible for removal and cleaning. By switching the valve handle to the alternate position, flow is shifted over to the other basket.

A duplex pressure gauge monitors the differential pressure between the inlet and outlet ports of the duplex strainer. The purpose of the duplex gauge is to provide a visual indication of a clogged strainer basket. To correctly use the gauge, it should be marked when the basket is clean. When the basket is clogged, the pressure reading is usually 5 to 10 psi above the clean-basket reading. If the pressure drop is less than the clean-basket reading, a check should be made for a damaged basket or missing basket.

The basket handle (spring handle) acts as a spring-load to seat and hold the basket in the housing. A damaged spring handle will permit debris to bypass the strainer basket and clog the heat exchanger tubes. In some cases, the basket may spin inside the duplex strainer and physically wear away the basket seat and/or the side of the duplex strainer. The duplex strainer would then have to be removed for extensive repairs, possibly off ship. New or replacement baskets should

always be checked for proper spring-handle pressure against the top of the basket cover. You should use only the correct gasket material for the basket covers, as specified in the COSAL. Inferior material can stretch and be forced out from under the cover, and then seawater could spray out and possibly flood the space.

## TEMPERATURE REGULATING VALVES

The temperature regulating valve regulates the amount of cooling water flowing through or bypassing a heat exchanger to maintain a desired temperature of distilled water going to the electronic equipment. Temperature regulating is usually provided by either a three-way or a two-way temperature regulating valve or a combination of both valves, as shown in figure 1-7. The three-way valve is used where seawater is the primary cooling medium in the heat exchanger, and the two-way valve is used where chilled water is the primary cooling medium.

### Three-Way Temperature Regulating Valve

The three-way regulating valve (fig. 1-7) is installed so that the incoming distilled water to the valve can be directed to the heat exchanger or caused to bypass the heat exchanger. More accurately, the distilled water is proportioned between these two paths. The valve senses the temperature of the distilled water downstream of the junction between the heat exchanger

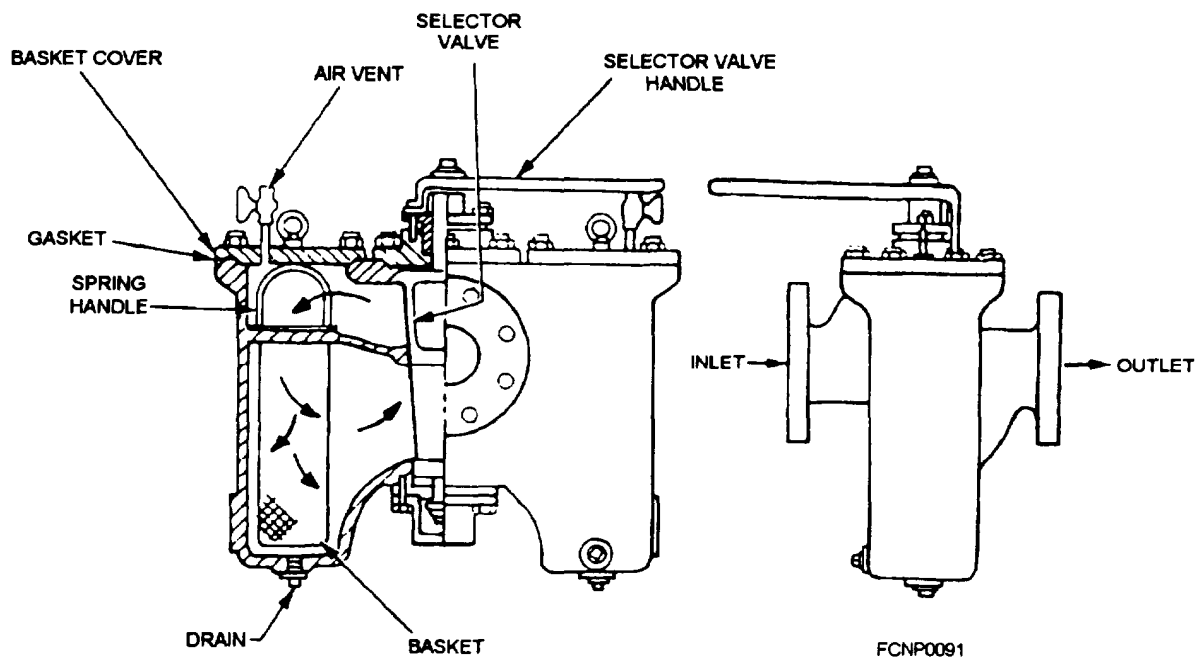


Figure 1-14.-Seawater duplex strainer.

outlet and the bypass and then proportions the two flows to obtain the desired temperature. The three-way regulating valve's range of operation is within  $\pm 5$  degrees of the setting on the valve.

Refer to figure 1-15 for the following description of the operation of the three-way regulating valve.

The bulb contains a volatile liquid that vaporizes and expands when heated. The generated pressure in the bulb is a function of the temperature around it. This pressure is transmitted through capillary tubing to the flexible bellows, which are loaded by the spring. Both bellows and spring rest on the end of the valve stem. Expansion or contraction of the bellows causes movement of the stem and the piston in the valve body. The flow of the liquid entering the valve at port A is

proportioned between ports B and C in the proper ratio to maintain the mixed flow temperature at the valve's *set point*. Total flow through the valve remains constant. Movement of the bellows is opposed by the spring, which is provided with a means to adjust the operating temperature by the spring-tension adjustment wheel. A drop in temperature at the thermostatic bulb reduces the pressure in the thermostatic assembly, causing it to exert less force, resulting in an upward movement of the stem because of the force of the spring. As the stem is connected to the piston, the piston also moves upward, enabling more liquid to pass from the bottom inlet through the right outlet (bypass) side and, at the same time, restricting flow through the left outlet (heat exchanger) side. A rise in temperature at the thermostatic bulb results in a reversed effect.

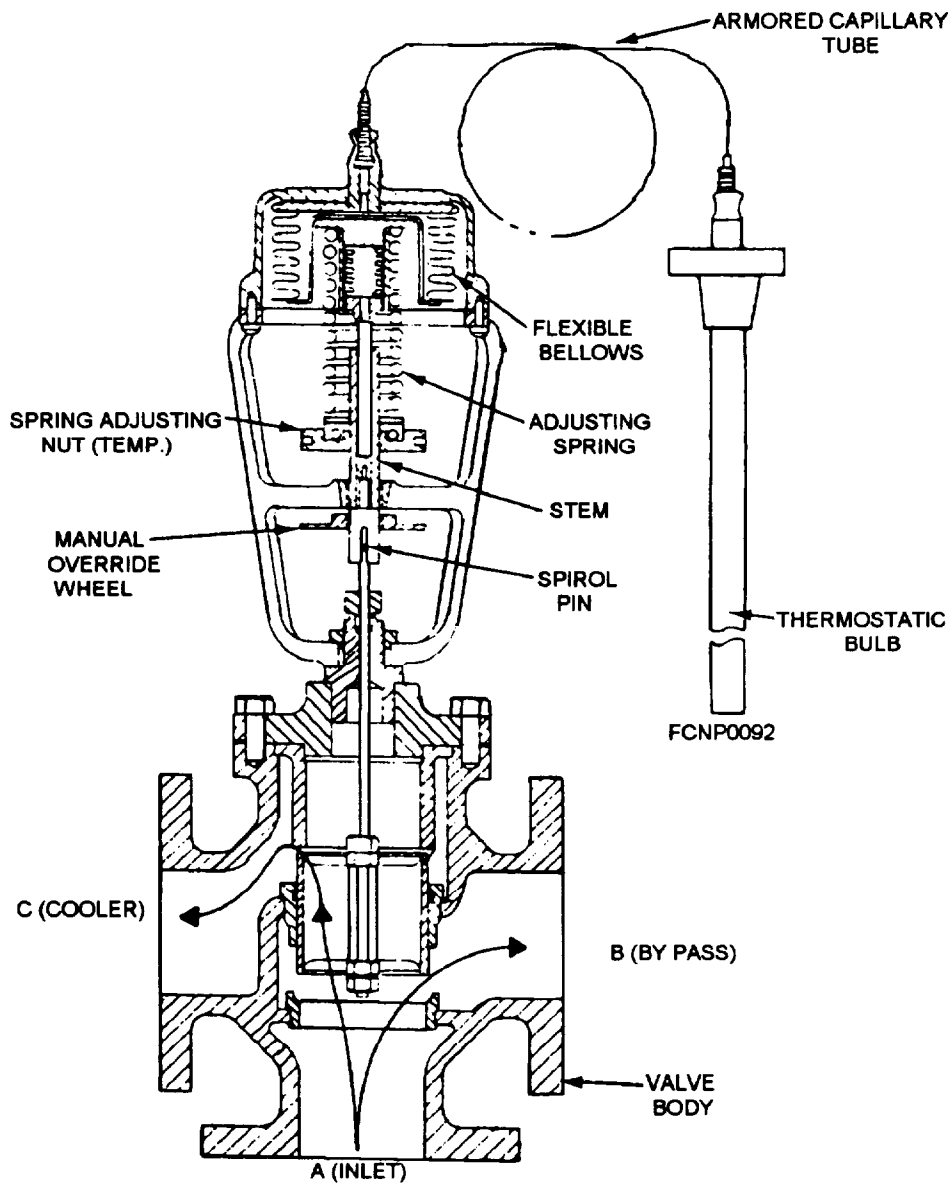


Figure 1-15.—Three-way temperature regulating valve.

## Two-Way Temperature Regulating Valve

The two-way temperature regulating valve (fig. 1-16) is normally installed in the chilled water supply to the heat exchanger with the thermostatic sensing bulb installed in the distilled water outlet from the heat exchanger.

It is shown as installed in the system on diagrams figures 1-7 and 1-8. The basic operation of the two-way temperature regulating valve is the same as the three-way temperature regulating valve. If the temperature of the distilled water is above the desired temperature, the two-way valve gradually opens to increase the flow of chilled water through the heat exchanger, which keeps the distilled-water temperature at the desired point.

Both the three-way and two-way temperature regulating valves have a manual override feature to provide uninterrupted service, if and when the thermostatic assembly fails because of damage to the capillary tubing or any other component of the thermostatic assembly. With the use of the manual override wheel, you can set the valve plunger/piston in the required position to operate the liquid cooling system by turning the manual override wheel down (from right to left) until it touches the spiral pin in the valve stem. Beyond this point, the valve plunger/piston is forced down, allowing the flow of cooling medium through the valve. With the use of the installed thermometers, you can decide if more or less cooling is needed by turning the manual override wheel up or down. The use of the manual override inhibits the thermostatic assembly and should only be used when

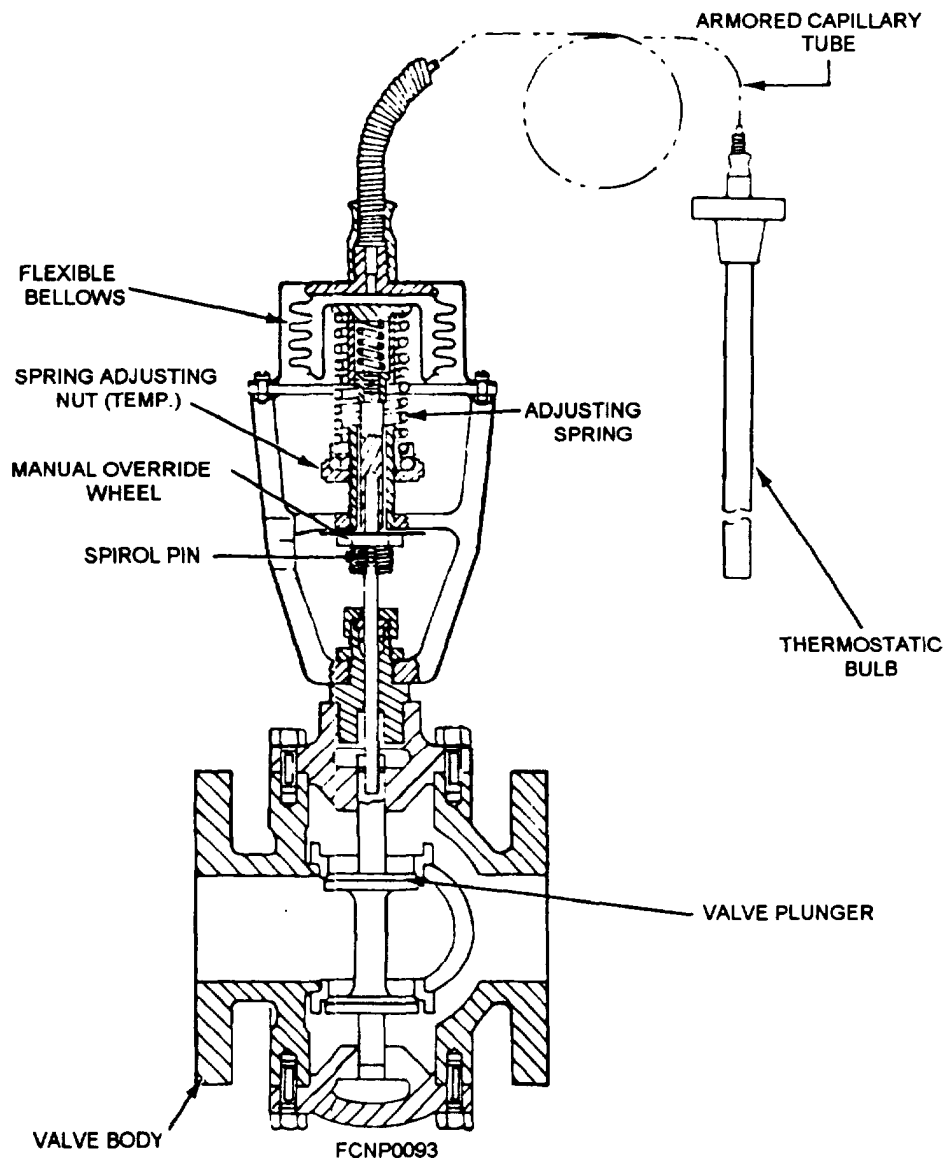


Figure 1-16.—Two-way temperature regulating valve.



the thermostatic assembly is inoperable. Corrective maintenance of the regulating valve consists of inspecting the valve for leaks and for freedom of stem movement, adjusting the set point at which the valve regulates, renewing the thermostatic assembly, and cleaning and restoring valve parts. Any time that you remove a valve, you should center punch a dot code on each piece to ensure that the valve and piping are installed in the original configuration. The three-way valve can be turned around, and the problem could go unnoticed until you try to align the temperature regulation of the cooling system. There are individual manuals for the temperature-regulating valves and they should be closely followed. For example, if you remove the top of the thermostatic assembly without chilling the temperature probe, the bellows will expand and rupture, making the unit worthless. To verify that the thermostatic assembly has failed, close valves upstream and downstream of the thermostatic bulb, drain the unit below the location of the bulb, and remove the bulb from its well. Place the bulb in a suitable vessel and observe the valve stroke while the bulb is alternately heated with hot water and cooled with cold water. If the valve thermostatic assembly does not respond, it has lost its thermostatic charge, and a new unit must be installed.

## FLOW REGULATORS

You will encounter many different types and sizes of flow regulating devices used in both the primary and secondary cooling systems. They are used to reduce the pressure or the flow of coolant through a cooling system.

The orifice plate is found primarily in the seawater cooling system. It is the simplest design of a flow regulating device, consisting of a steel plate with a hole in it. With constant known seawater pressure and with a given hole size, the volume of water through the device can be determined. The use of an orifice plate is limited to where the input water pressure is essential y constant, such as the ship's firemain. The orifice plate is normally installed between two pieces of flanged pipes upstream from the heat exchanger as shown in figures 1-6 and 1-7. This will reduce the ship's firemain pressure below the pressure in the secondary cooling system. As we have indicated earlier, should one of the heat exchanger tubes fail, the seawater pressure is lower than the distilled water pressure; therefore, it would not contaminate the secondary cooling system. The secondary cooling system would force distilled water into the primary cooling system. A ruptured heat exchanger tube or a bad single tube sheet in a heat exchanger would give no visual indication of water loss except for the indication

on the expansion tank sight glass. To stabilize the flow of seawater and to prevent jet erosion of the heat exchanger and associated piping, the orifice plate should be installed with at least 15 pipe diameters of straight pipe upstream from the heat exchanger. When there is a drop in the heat exchanger primary input pressure and the seawater supply pressure has not changed, you should first check the duplex strainer differential pressure gauge to ensure that the duplex strainer is clean. Then the orifice plate should be inspected for deposits or particles that could restrict the seawater flow. You should also inspect the orifice plate for erosion damage of the hole diameter. The orifice plate should be replaced when there is an increased flow of seawater to the point that it could damage the heat exchanger. Never use the seawater valves to throttle (partially closed) the flow of seawater in the primary cooling system, because the seawater will erode the internal parts of the valve. The damage to the valve would require extensive repair or replacement, because the valve would no longer close properly.

When used with the chilled-water system, the constant flow regulator (variable orifice, fig. 1-17) is installed downstream from the heat exchanger. This restricts the flow from the heat exchanger and keeps the heat exchanger fully submerged for greater efficiency (heat transfer). This type of flow regulator is not used in the seawater system because the internal parts would easily become fouled with marine growth and deposits. The operation is dependent on the movement of the orifice plugs (neoprene) to regulate the flow of water.

Another type of flow-regulator valve (equipment flow) used primarily with electronic equipment to regulate the flow of distilled water through the

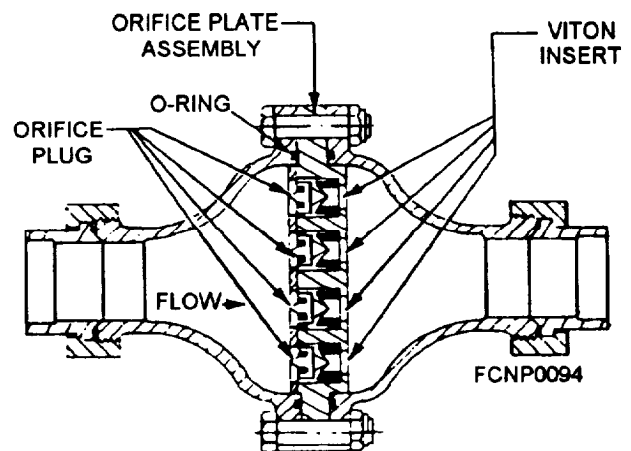


Figure 1-17.-Constant flow regulator.

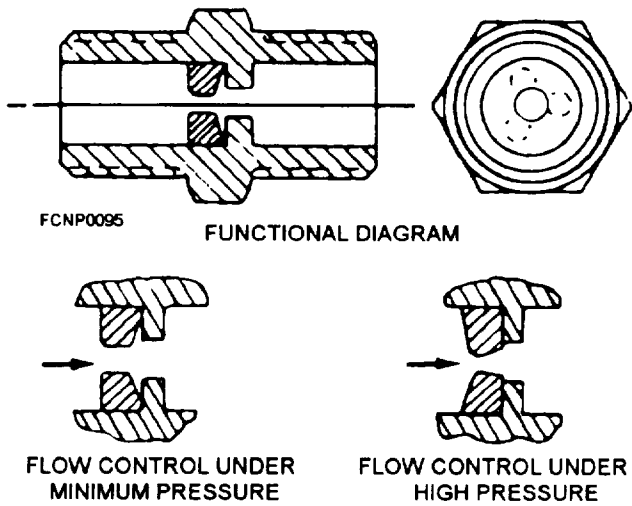


Figure 1-18.—Equipment flow regulator.

individual cabinets and components is shown in figure 1-18. It maintains a constant flow of distilled water with limited changes in the input pressure. At the minimum water flow, the total amount of water is passed through the device. As the flow of water increases to the flow regulators maximum limit, the water flow is restricted by the insert's movement, which causes the hole size to decrease. In this way, the flow of water is regulated. The amount of water that the flow regulator will pass is usually stamped on the side of the regulator. This is because the external dimensions are usually the same for differently rated regulators.

The nominal flow rate of the equipment-flow regulator can be from one-half to more than 12 gallons per minute. It is normally used with a pressure-regulating valve. You should be aware that this type of regulator can deteriorate over time. The insert can become distorted and cause a reduction in the flow of water. With a drill index set, you can use the back of a drill bit to measure the hole size and compare it to a known good constant-flow regulator or the equipment manual. Do not drill out the insert to restore it to the proper size, because it will become distorted. Its distorted shape would prevent the insert from regulating the distilled water flow.

The pressure-regulating valve (fig. 1-19) is used to regulate a major section of the coolings system; whereas, the flow regulator is normally used to regulate an individual feeder line to an individual component or cabinet. The pressure-regulating valve usually has a pressure-relief valve downstream from it to protect the equipment from being over pressurized. Should a failure occur in the pressure regulating valve, the pressure-relief valve would keep the water pressure at a safe level to prevent equipment damage.

The operation of a typical pressure-regulating valve is as follows: When a drop in downstream (outlet) pressure occurs, the pressure in the diaphragm chamber is lowered concurrently. The downstream side of the valve is connected to the diaphragm chamber through a narrow opening along the periphery of the piston. The

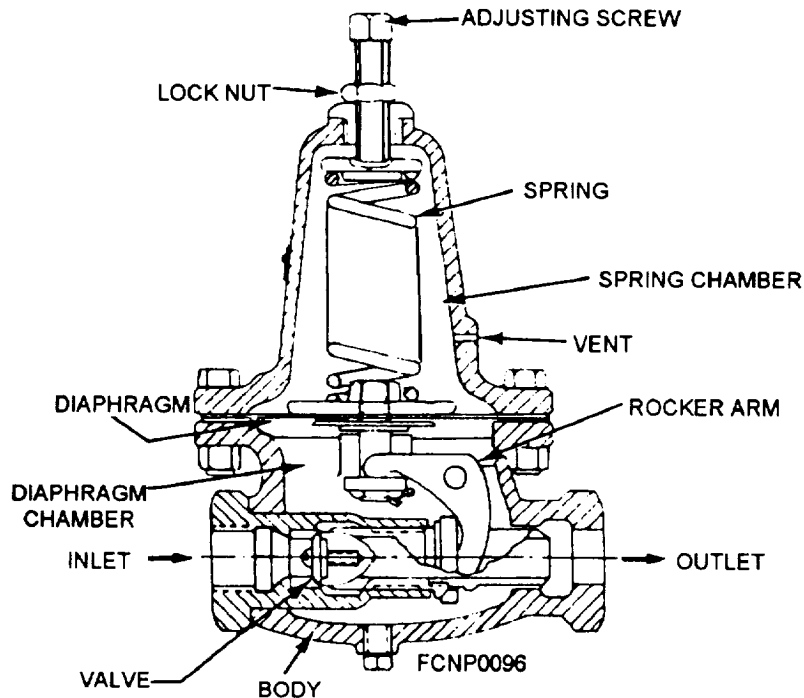


Figure 1-19.—Pressure regulator.

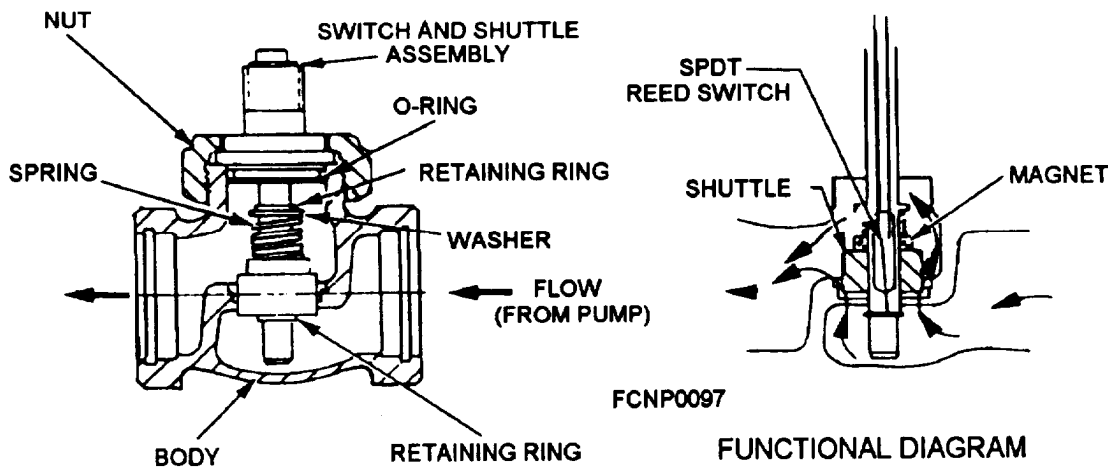


Figure 1-20.-Cooling system flow switch.

spring is allowed to force the diaphragm downward releasing the tension on the rocker arm, and the inlet pressure opens the valve. The outlet pressure increases to the preset level, and the static control chamber pressure balances the valve spring to maintain a regulated downstream pressure to the served equipment.

You should take the following precautions with this type of valve. Ensure that the locknut is loose before you adjust the adjusting screw; otherwise, you could strip the threads of the brass spring chamber. If water should start leaking out of the vent, the valve should be serviced for a leaking diaphragm. This should be done before it ruptures. The vent should never be plugged or painted over. Either would inhibit its operation.

If you should remove a flow regulator or a pressure regulator, make certain that you reinstall it correctly, because it can be installed backwards. Look for an arrow for direction of flow or the inlet and outlet stamped on the body of the device. Pipe-joint sealant should be used only on the male pipe threads and not closer than one thread to the open end to seal the device. Improper use of anti-seize tape can result in the tape being cut loose and circulated in the cooling system, which could plug up a small component.

## FLOW MONITORING DEVICES

Most systems incorporate one or more types of devices to monitor the flow of distilled water through the system to ensure that the electronic equipment is supplied with an adequate flow. A low-flow switch is normally found in the secondary cooling system to monitor the overall coolant flow. It is electrically connected to a common alarm circuit to warn personnel when the system flow rate drops below a specified minimum value. A typical cooling system low-flow

switch is shown in figure 1-20. The main operating parts consist of a hermetically-sealed reed switch and a permanent magnet attached to an internal shuttle. With the proper flow of coolant, the shuttle moves the magnet up and away from the reed switch. This keeps the reed switch contacts open. When the coolant flow drops below the minimum for a flow switch, the shuttle is forced down by the spring to a balanced condition against the flow of the distilled water. The magnetic field is now close enough to cause the reed switch to close and activate the low-flow alarm.

A much smaller flow switch is used in electronic equipment to monitor the flow to individual components. Atypical equipment flow switch is shown in figure 1-21. The one depicted contains a fixed orifice.

The flow of water through the orifice causes a pressure drop across it. This pressure drop causes the diaphragm to move against the spring. When the

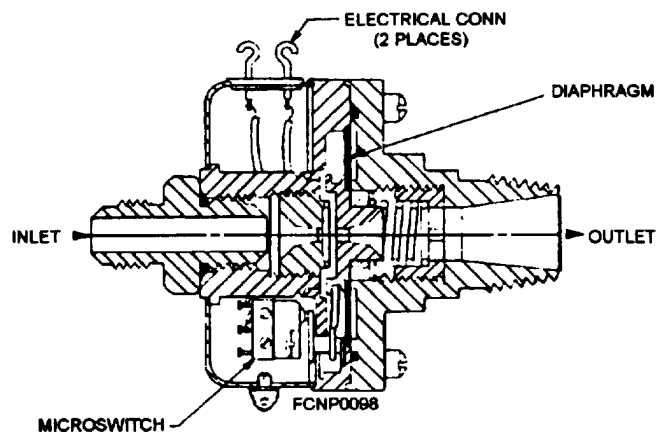


Figure 1-21.—Equipment flow switch.

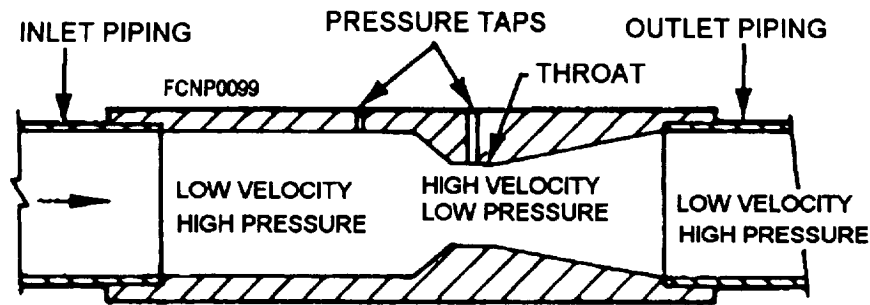


Figure 1-22.-Venturi flowmeter.

differential pressure (pressure drop) is sufficient, the microswitch will activate to indicate that the switch has the proper flow through it. You should be sure that the flow switch is defective before overhauling or replacing it. The problem could be a partially closed supply/return valve, obstruction in the coolant line, insufficient coolant pressure, or many other things. By using the coolant system pressure gauges and/or the installation of a permanent or a temporary in-line flowmeter, you should be able to correctly isolate the problem.

In the secondary cooling system, a full-flow system flowmeter (figs. 1-6, 1-7, and 1-8) is provided to enable you to monitor the total system flow rate for troubleshooting purposes. There are three types of system flowmeters installed aboard ship. All of them serve the same functional purpose of monitoring coolant flow rate. You will encounter the venturi-type flowmeter, orifice-type flowmeter, and the rotameter flowmeter. Most systems incorporate one secondary coolant flowmeter and one or more smaller flowmeters to ensure that the electronic equipment is being supplied with an adequate flow of coolant.

In the venturi-type flowmeter (fig. 1-22), as the coolant approaches the contracted portion (throat) of the meter, its velocity must increase as it flows through the contracted zone. The angle of approach is such that no turbulence is introduced into the stream. A pressure tap is located at the side wall in the pipe ahead of the meter, and another one is located at the throat. The increase in velocity of the coolant water through the throat results in a lower pressure at the throat. The flow rate is proportional to the difference in pressure between the two taps. The gradual tapering of the meter walls back to pipe size downstream of the throat allows the coolant water to slowdown with a minimum of lost energy. This allows a recovery of nearly 99 percent of the pressure on the approach side.

To monitor the amount of flow through the venturi-type flowmeter, a differential pressure gauge is used to monitor the pressure difference between the two

pressure taps. A calibration chart is usually supplied with the flowmeter to convert the differential pressure to gallons per minute (gpm), or the face of the meter may indicate readings in gpm.

The orifice flowmeter works in the same manner as the venturi flowmeter, but its construction is much simpler and less expensive to manufacture. In place of the tapered throat, the orifice flowmeter uses a flat plate with a hole in it, which causes a considerable loss of pressure downstream. The efficiency of this type of flowmeter can be as low as 65 percent.

The rotameter (fig. 1-23) is a variable area orifice meter that functions by maintaining a constant differential pressure with varying flow. The rotameter consists of a float positioned inside a tapered, tempered glass tube by the action of the distilled water flowing up

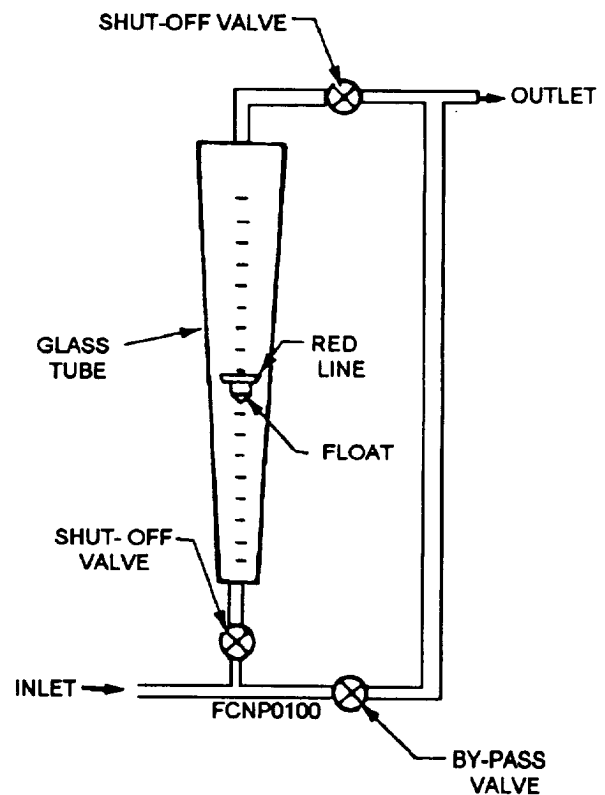


Figure 1-23.—Rotameter.

through the tube. The flow restriction is the space between the float and the tube wall. This area increases as the float rises.

The differential pressure is fixed depending upon the weight of the float and the buoyant forces resulting from the combination of float material and the distilled water's specific gravity. The tapered tube of the rotameter is usually glass with calibration marks reading directly in gpm. The major advantage of a rotameter over the venturi orifice meter is the visibility of the coolant. This allows quick determination of excessive entrained air in the coolant.

## CIRCULATING PUMP

Each cooling system has two secondary distilled water circulating pumps (fig. 1-24), which are identical in construction and capacity. One pump is designated for service, and the other is held in standby in case the designated pump fails. Should the pump designated for operation fail, then the standby pump would be used in its place. The pumps should be operated alternately (every other week) to prevent deterioration of their shaft seals, equalize wear, and permit PM actions to be performed regularly.

The two circulating pumps used in the liquid cooling system are single-stage centrifugal pumps closely coupled (pump is built onto the motor) to a constant-speed electrical motor. You may run into an older system that uses a separate pump and motor joined by a flexible coupling. The centrifugal pump has two major elements—the impeller rotating on the extension of the electric motor shaft and a casing that is called the impeller chamber. The impeller imparts the initial

velocity to the coolant. The impeller chamber collects the high-velocity coolant from the impeller and guides it to the pump outlet. A mechanical shaft seal is used to eliminate external leakage. This seal is lubricated and cooled by water ducted from a high-pressure zone of the pump. You will find a vent valve located on the top of the pump casing to remove air and ensure the pump is primed with coolant.

Located at the outlet of each pump is a check valve to prevent coolant from the outlet side of the operating pump from circulating to the return side of the coolant system through the standby pump. Hand-operated valves at the pumps are used to isolate the pumps so they can be removed for maintenance.

Each secondary circulating pump is rated in gallons per minute (gpm) output at a specified head pressure in pounds-force per square inch gauge (psig) pressure, or in feet of water. The rating is usually at the pump's maximum efficiency point, and it will vary depending upon the pump design. On all pumps, as the output pressure increases, the output flow decreases, and vice versa. This relationship is almost linear but differs with different pump designs. However, this condition means that if a restriction is placed in the pump output lines, the pressure will increase and the flow will decrease. The restriction could be a partially closed hand valve, dirty filter, damaged or crimped piping or hose, and so forth. In figures 1-6, 1-7 and 1-8, the pump performance indicators are the suction and discharge pressure gauges and the system flowmeter. If you start a pump and pressure fails to buildup, you should exhaust air through the vent cock on the top of the pump casing. You should ensure that the suction valve is fully opened and there is

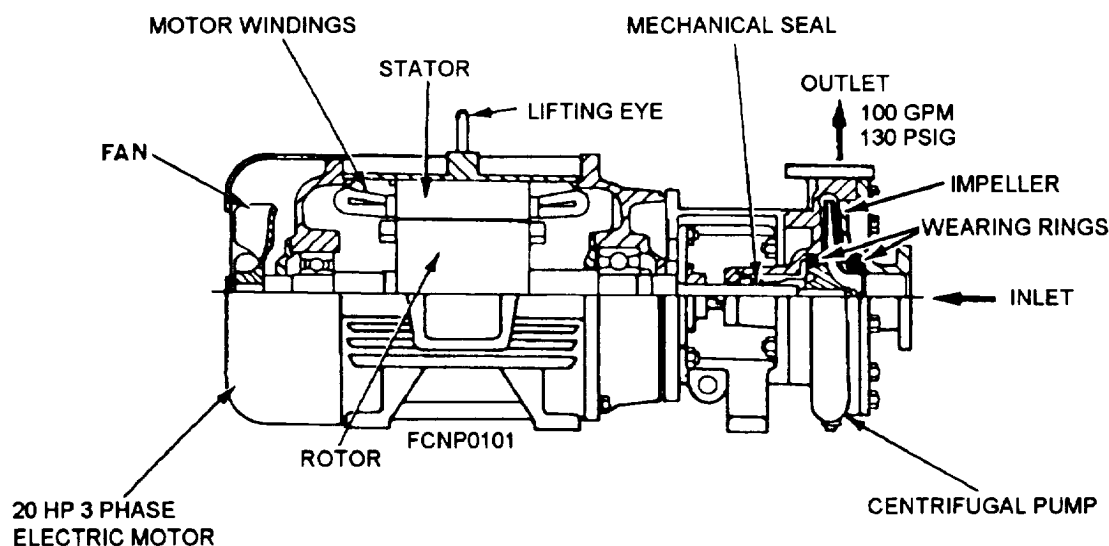


Figure 1-24.—Distilled water circulating pump.

pressure on the pump suction pressure gauge. If flow doesn't develop, check for clogging and wear.

You should not operate a pump without coolant flow. Some pumps have a small recirculating line that enables the pump to recirculate coolant from the discharge side of the pump to the suction side. This provides for a flow of coolant through the pump if an inlet/outlet valve to the pump is closed with the pump running. Whatever the case, you should keep in mind that the operation of a pump without the normal flow of coolant through it will result in overheating and seizure of the pump. Corrective maintenance of the circulating pump consists of repairing leaks, replacement of the mechanical seal, and cleaning the internal parts. This type of maintenance is performed by personnel of the ship's engineering department. You should provide assistance if it is needed.

## DEMINERALIZER

The secondary cooling system water purity is maintained in an ultrapure state by a demineralizer. By maintaining the coolant at a high degree of purity, you

minimize corrosion and the formation of scale on the radar unit. Corrosion or scale on a high-heat-density component such as waveguide dummy loads and klystrons results in the formation of a thermal barrier. The thermal barrier reduces the effectiveness of heat transfer at normal operating temperatures. This leads to premature failure of the components.

The demineralize (figs. 1-6, 1-7, and 1-8) is connected between the secondary cooling system supply and return lines to circulate water through it. The demineralize is sized so that 5% of the cooling system volume passes through the demineralize every hour. The coolant is purified by organic compound adsorption (if required), oxygen removal, ion exchange processes, and submicron filtration. Shown in figure 1-25 is a typical three-cartridge demineralize. Some demineralizes use only two cartridges; one of the cartridges is a combination cartridge that provides organic compound adsorption, if it is required.

The input supply valve to the demineralize unit, depicted in figure 1-25, must be adjusted on system start-up, and periodically thereafter to maintain the

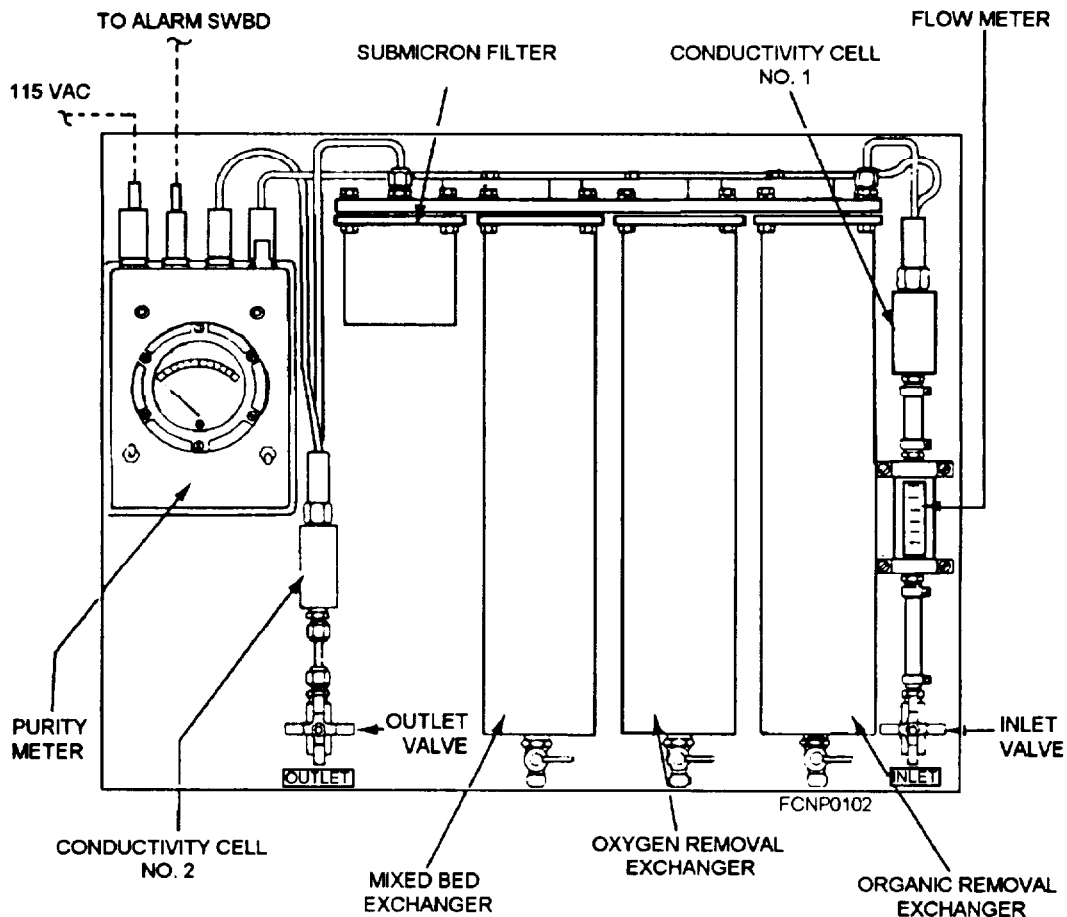


Figure 1-25.—Demineralizer.

correct flow rate through the flowmeter. The high of a flow rate can damage the cartridges. If the flow rate cannot be increased to the proper rate with the inlet supply valve fully open, you should check to ensure that the outlet valve is fully open. The submicron filter is used to remove small particles from the coolant flow having a size greater than 0.5 micron. If the filter becomes clogged, it also reduces the flow of coolant. This necessitates a change of the filter cartridge or filter sheet (membrane). To change the filter, the demineralize valves must be properly positioned.

If the filter cartridge or membrane continually becomes clogged (about one-half hour or less after replacement), the usual cause in the distilled water system is the presence of bacteriological impurities. Bacteriological impurities introduced into the secondary liquid cooling system using distilled water may exist in the demineralize cartridges and/or the whole secondary cooling system. If the bacteriological impurities are in the whole secondary cooling system, the growth rate in a warm water environment could be of a magnitude that exceeds the capability of the demineralize. You will have to determine the source and magnitude of contamination. However, it should be noted that bacteriological contamination in a secondary cooling system that uses distilled water and ethylene glycol is highly improbable.

Improper handling or storage of the cartridges could cause the cartridge to be a source of contamination. You should always store the cartridges in a cool, dry area. Exposure to heat hastens the growth of any biological contaminants that may have entered the cartridges. You will encounter three different types of cartridges. The first cartridge is the organic removal cartridge. It contains granulated activated charcoal (carbon) that removes large organic molecules and chlorine by adsorption. It is always installed in the first exchanger (if required) to prevent organic molecules from fouling the remaining cartridges. The second cartridge is the oxygen removal cartridge. It is composed of anion resins that remove oxygen from the water by ion exchange of sulfite ions to sulfate ions. By conducting a standard oxygen test (or if the cooling system has an oxygen analyzer installed), the quality of the outlet water from the demineralize can be tested for oxygen content so that you will know when to replace an oxygen cartridge. When the oxygen cartridge is near exhaustion, it will have a urine odor, which is given off by the sulfate. The third cartridge is the mixed-bed cartridge. It is filled with cation (positive charge) and anion (negative charge) resins, which remove solids, dissolved metals, and carbon dioxide. The charged

resins exchange ions with the contaminants, thereby removing them and leaving pure deionized coolant. You should replace the mixed-bed cartridge when the purity meter indicates a low outlet purity.

As indicated in figures 1-25 and 1-26, two conductivity cells monitor the coolant through the demineralize. The first cell measures the purity of the coolant as it enters the demineralize. The second purity cell is used to measure the purity of the coolant as it leaves the demineralize. The conductivity cell consists of two electrodes immersed in the coolant flow path. The electrodes measure the conductivity of the coolant, which varies with the amount of ionized salts dissolved in it. If the impurity content increases in the coolant, the purity meter indicates higher conductance.

On some purity meters, the purity of the coolant is displayed as resistivity. In this type of meter, an increase in the impurity of the coolant causes the meter to indicate a low resistivity. Conductance is the reciprocal of resistance, and is measured in micromhos/cm. Resistivity is measured in megohms/cm. You can convert from conductivity to resistivity by taking the reciprocal of conductivity. Similarly, the reciprocal of resistivity is equal to the conductivity. A comparison of both ways of measuring the purity of the coolant is

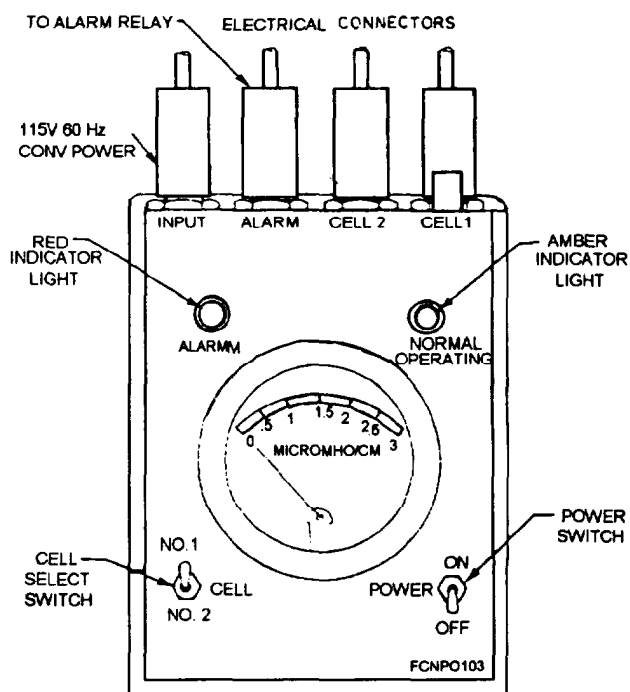


Figure 1-26.-Purity meter.

shown in table 1-1. The purity meter indications will vary with ionized salt concentration and the temperature of the coolant flowing through the cell. The temperature effect is canceled by a built-in temperature compensation circuit.

The inlet conductivity is compared to a preset value of cell conductance to actuate an alarm circuit when the purity of the water drops below the preset level. In addition, the purity meter provides direct readings of the water purity at the inlet and outlet of the demineralize. Typical operating requirements for the demineralize are conductivity 1 micromho/cm at 77°F (resistivity 1 megohm/cm at 77°F), oxygen content 0.1 ppm by weight, and mechanical filtration 0.5 microns absolute.

When water has been circulated through the system for extended periods of time, a high resistivity or low conductivity reading may be indicated on both input and output samples. This condition is highly desirable and indicates that all ionizable material has been properly treated, and that the demineralize is maintaining a high degree of purity. When a system is filled with a fresh charge of water, it should be allowed to circulate for approximately 2 hours before comparing the input and output readings. During the initial circulation period, the resistivity readings vary because of the mixing action of water that has been treated by the demineralize with the fresh charge of water. A properly operating system can supply water of acceptable purity in 4 to 8 hours. Water in a system that has been secured for any length of time should be of acceptable purity within 2 hours. The resistivity/conductivity reading required for a specific installation must be maintained for optimum operation of the cooling water system.

Your first indication of a problem in the demineralize is usually indicated by abnormal purity meter readings (too low or too high), an abnormal flowmeter reading, and/or a light and audible warning from the purity monitor. Some purity monitors can be tested for accuracy by a built-in test function on

**Table 1-1.—Distilled Water Resistivity Versus Conductivity Data**

Resistivity (megohmscentimeters)	Purity	Conductivity (micromhos per centimeter)
10.0	↑	0.1
2.0	Increasingly better purity.	0.5
1.0		1.0
0.5		2.0
0.1		10.0

the meter to establish if the problem is in the purity monitor. If the purity monitor does not have a test feature, then use the calibration plug in place of one of the conductivity cells to test the operation of the purity meter. Most of the time, only routine maintenance is required to return the demineralize to its normal operating condition.

Maintenance of the demineralize consists primarily of the scheduled replacement of cartridges (before they are exhausted) and clogged filters. Obtaining satisfactory service life from the cartridges and filters is largely dependent on minimizing external contamination. Replacement cartridges must be kept sealed and stored in a cool dry place until used. The circulating system must be kept tight to reduce the need for makeup water. Makeup water, in any case, should be as particle-free as possible and should not exceed 0.065 ppm chloride.

## OXYGEN ANALYZER

In some secondary cooling systems, an oxygen analyzer is installed to measure the amount of dissolved oxygen in the liquid coolant. The presence of oxygen causes oxidation that leads to the formation of scale in the cooling system. An oxygen analyzer has an oxygen sensor installed in the supply side of the secondary cooling system. The sensor is an electrolytic cell in an electrolyte solution or gel. A thin membrane covers the end of the sensor, which is inserted in the coolant. This membrane is gas permeable to the dissolved oxygen in the secondary coolant. This allows the oxygen to pass through the membrane. The oxygen reacts with the electrolyte, which causes a proportional change in the amount of current flow in the sensor. The sensor's electrical output is measured and displayed on the oxygen analyzer's meter. The meter is calibrated to read the oxygen content in parts per million or billion.

Because of solid-state electronics and the few components used, the oxygen analyzer requires very little maintenance other than the cleaning and changing of the electrolyte in the sensor. When the meter on the analyzer requires frequent calibration because the meter readings are drifting or changing sharply, you should recognize that the analyzer has a bad sensor. When you clean and recharge the sensor, use caution to prevent contamination of the membrane from the oil on your fingers.



# COOLANT ALARM SWITCHBOARD

The cooling system alarm switchboard (SWBD) monitors various conditions to alert you to a problem that may develop in the cooling system. When an abnormal condition occurs, the alarm SWBD indicates the fault condition with both a visual and an audible

alarm. The alarm SWBD usually has several remote bells and lights in CIC and other electronic spaces aboard ship to indicate a fault condition. The *alarm* SWBD is located in CIC or the coolant pump room. There are several standard types of alarm switchboards used throughout the Navy. A common type of alarm SWBD is shown in figure 1-27.

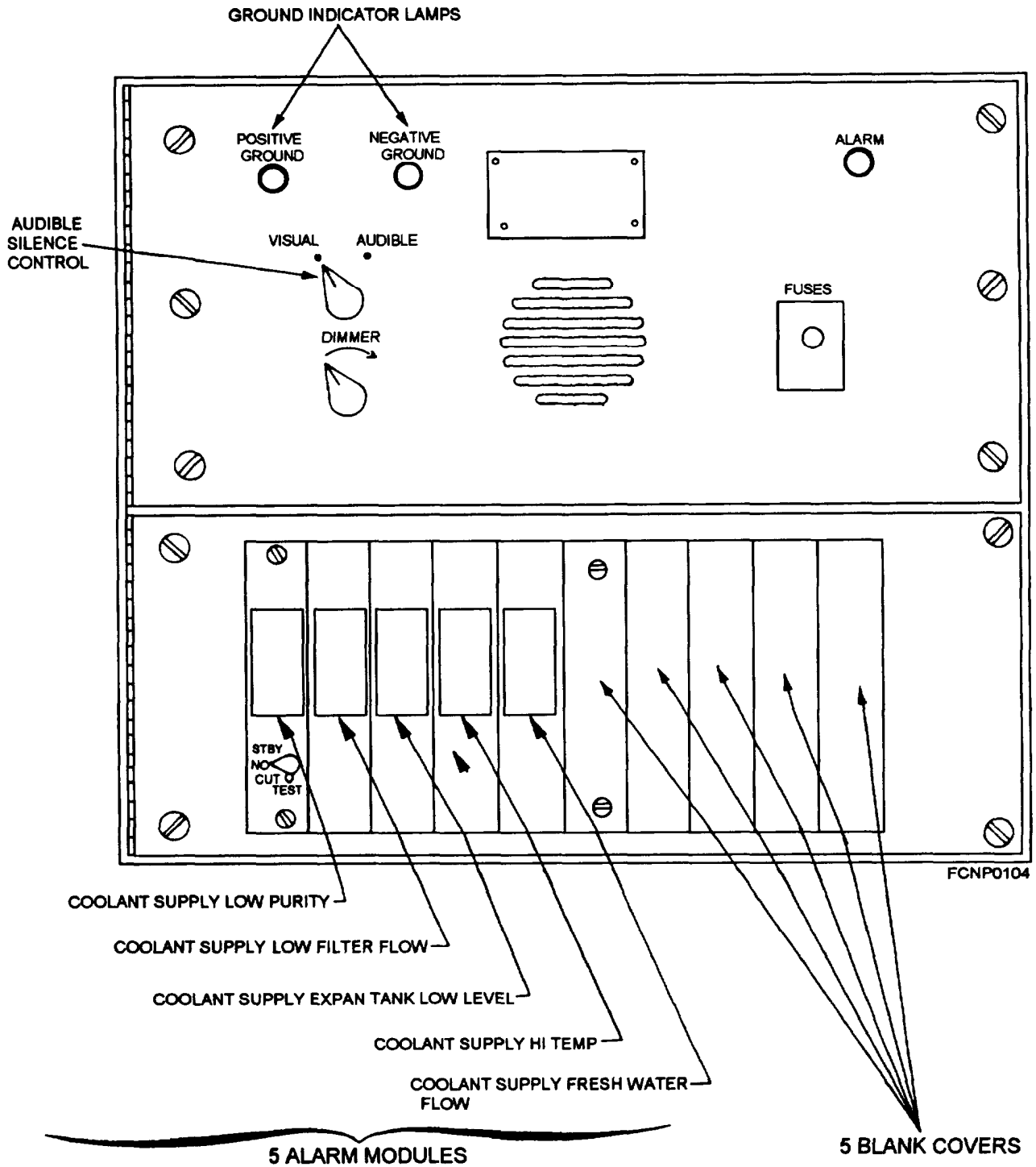


Figure 1-27.-Cooling system alarm switchboard.

On the main alarm panel, there are two GROUND INDICATOR LAMPS (fig. 1-27) to indicate the presence of a ground in the alarm system. All shipboard alarm panels and remote sensors are electrically isolated from the ship's ground. The only exception is the ground fault detector, which is connected to ground for ground monitoring. If one of both lamps light, you should have the alarm SWBD and its remote sensors. The AUDIBLE SILENCE CONTROL is a two-position switch that permits silencing (VISUAL POSITION) the audible alarm on the main panel. The ALARM lamp on the main panel is lighted when the AUDIBLE SILENCE CONTROL is placed in the VISUAL position, and the system is in an alarm condition.

The lower half of the alarm panel (fig. 1-27) holds the alarm modules that are connected through the alarm panel to the remote sensors. On the panel depicted, there are only five alarm modules used while the rest is blanked off with covers. Should additional remote sensors be installed at a later date, a new alarm module is plugged into the lower panel for each sensor installed. Each alarm module includes a center-divided lighted display. Either half can independently display a steady red light, a flashing red light, or no light, depending upon the circuit logic. The six possible combinations of alarm module lights and the appropriate audible alarm are shown in figure 1-28. Located on the lower half of each alarm module is a four-way position switch that allows you to place the individual alarm module in the following modes:

- **NORMAL**. This is the normal operation mode. With the sensor contacts open, the upper indicator lamp in the module will be on steady while the lower lamp is off. If an alarm condition occurs, the sensor contacts will close; the upper lamp will then flash while the lower lamp remains off and an alarm command from the module actuates a tone generator, producing a wailing alarm. If the sensor loop is open-circuited, with the selector switch in the normal position, the alarm module signals a supervisory failure; in this case, the upper lamp will be off while the lower lamp will be steadily on, and the tone generator will come on, producing a pulsating alarm.

- **STANDBY**. This is the position for acknowledging an alarm. If the selector switch is moved from the normal to the standby position during an alarm condition, both the upper and lower indicator lamps will be steadily on and the audible alarm will be silenced. When the alarm condition is cleared with the selector switch in the stand-by position, the lower lamp changes to a flashing mode and the upper lamp goes out.

Also, a command is fed to the tone generator, producing a pulsating alarm. This pulsating alarm signal informs the operator that the selector switch should be returned to the normal position.

- **CUTOUT**. With the selector switch in the CUTOUT position, the upper lamp is out while the lower lamp is steadily on. In this position, power is removed from the sensor loop to facilitate maintenance.

- **TEST**. This selector switch position simulates an alarm condition. The upper indicator lamp will flash while the lower lamp will remain off. A wailing alarm is produced.

Your proper response to the coolant alarm SWBD could mean the difference between a small service problem or the markings of a much larger disaster. For example, the COOLANT SUPPLY EXPANSION TANK LOW-LEVEL alarm module senses a low coolant level in the expansion tank, immediate action must be taken. If the tank should empty, the pump will draw air into the lines and force it throughout the secondary cooling system. This would require additional maintenance to correct the problem.

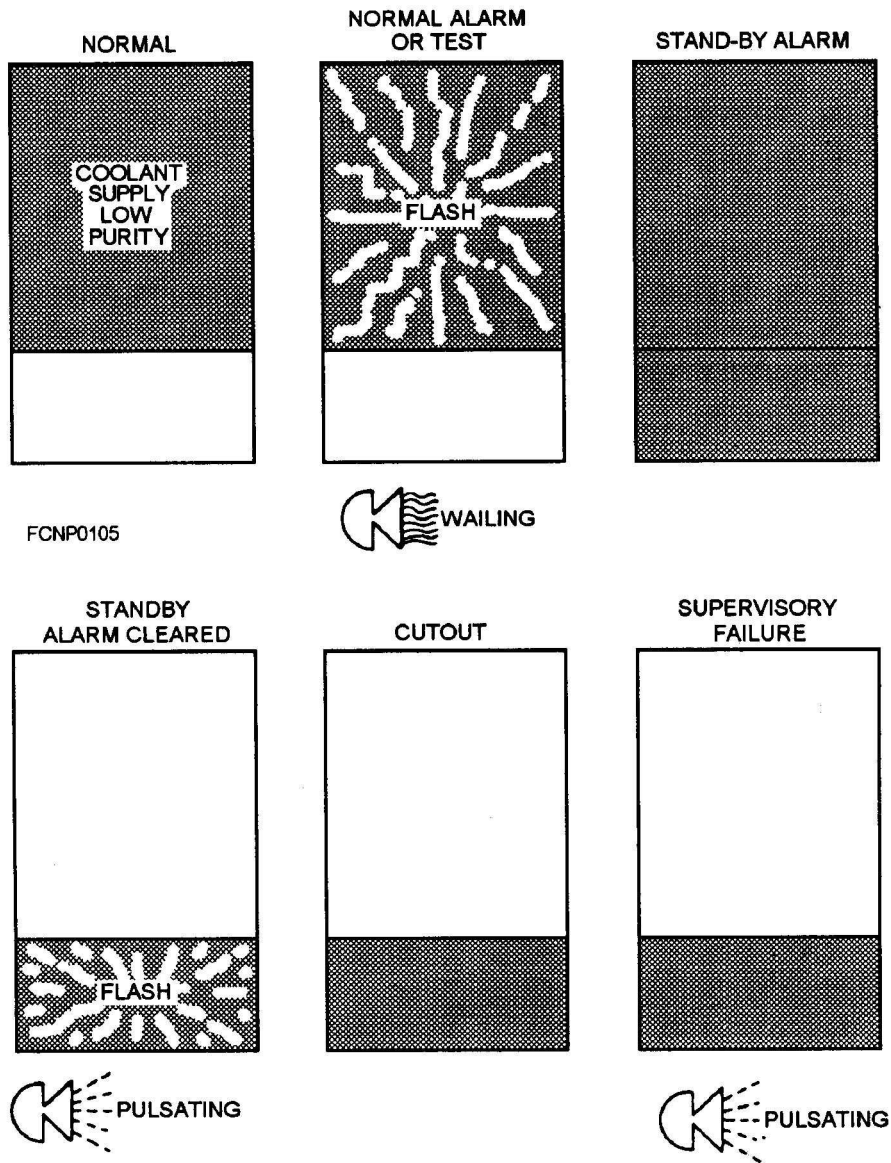
## WAVEGUIDE FLOODING

An improperly maintained liquid cooling system can cause a major disaster in your waveguide system, if it is liquid cooled. The damage caused by waveguide flooding can easily run into thousands of dollars and include the expenditure of hundreds of manhours by ship's force.

Various components of high-powered radars, such as dummy loads, load isolators, and circulators are cooled by the use of liquid coolant. These components use a ceramic plug (or disk) in a water-cooled load. Transmitted rf energy passes through the plug and is absorbed as heat by liquid coolant flowing through the load. The plug acts as a window for rf energy, and at the same time, forms a watertight seal between the waveguide and the coolant jacket of the load.

Particles of oxidation and dirt from a dirty coolant system can buildup on the coolant side of the ceramic plug. The buildup can create an impedance mismatch or hot spot. This condition can generate an arc, which carbonizes the ceramic plug so that coolant can leak through or around the carbonized plug.

Since a nominal 80-psig pressure differential exists between the coolant in the load and air in the waveguide, coolant can flow from the water load into the waveguide, resulting in waveguide flooding. Once the



**Figure 1-28.—Alarm switchboard visual displays and audible alarms.**

coolant has entered the waveguide, it can flow through the various sections of the waveguide system. It can cross over to other waveguide systems through the common dry air lines that are connected to the waveguide. As you can see from the above description, if the coolant leak is severe or remains undetected for a long period of time, a leaking water load can completely fill the waveguide system with coolant.

You have to follow a logical troubleshooting procedure. If the problem is a common one in a specific combat system equipment, there will probably be a technical bulletin issued that describes how to isolate the flood damage. The following is a condensed procedure for waveguide flooding.

#### **ISOLATE EXTENT OF FLOODING**

It is imperative that the amount of waveguide contamination be determined before the microwave system is drained of water. If the exact level of contamination is not determined, many microwave components may needlessly be removed and many manhours expended unnecessarily. You will have to secure the cooling system and close all valves to the affected areas of the radar. If the cooling system uses a pressurized expansion tank, you will have to bleed off the air pressure. If you can still see the coolant in the sight glass of the expansion tank, you can estimate the amount of coolant missing since the system was last filled. Use the estimated loss to determine the amount of contamination that may have occurred. The dry-air

system should be secured and all valves closed to prevent movement of this coolant.

You should start at the highest point in the waveguide system and work down to the flooded area of the waveguide. By proper isolation of the flooded waveguide, the extent of repairs can be minimized. Ensure that you do not have trapped coolant in the dry-air lines. Electrical power should be secured and tagged out to prevent a shock hazard because of water that has spilled.

## **CLEAN-UP PROCEDURE**

First drain the contaminated waveguide by opening the waveguide at convenient points. Next, remove the components to a clean work area, being careful not to damage them. You should mark each piece to indicate its location and position so that it can be properly reinstalled.

Each section of waveguide has to be cleaned by scrubbing it inside and out with hot soapy water. Long sections of waveguide can be cleaned by pulling a clean lint-free rag through each section. A soft cotton cord (not waxed lacing cord) can be used to accomplish this. The rag should be pulled through each section in both directions. You must use extreme care to avoid damage to such things as attenuator vanes (thin glass) or termination load pieces inside the waveguide components.

Some waveguide components are epoxyed together, and it may not be possible to disassemble them. After cleaning components of this type with hot soapy water, rinse each piece with hot fresh water and then with hot distilled water. Dry each component, and then inspect the interior for damage with a very bright light. (Do NOT use a flashlight because it is not bright enough.) In some cases, the removal, installation, and calibration of balanced waveguide runs in the antenna are considered beyond ship's force capability. This is because of the special tools and test equipment required.

The waveguide should be reassembled with new gaskets. Also, all damaged or broken components should be replaced. Purge all air lines before reconnecting to the waveguide. After assembly, the waveguide should be purged with dry air for several hours. This is done before the use of the waveguide to ensure the removal of all moisture.

Also, before the use of waveguides, you should inspect other water-cooled components for possible deterioration. By completing this step, you can prevent

a reoccurrence of waveguide flooding caused by oxidation or dirt buildup on the coolant side of the high-power components.

## **COOLING SYSTEM MAINTENANCE RESPONSIBILITY**

The most important responsibility that you have that will extend the life of the cooling system components and increase the reliability of the cooling system is how you schedule and perform preventive and corrective maintenance according to the Planned Maintenance System (PMS). Properly performed preventive maintenance drastically reduces the amount of corrective maintenance necessary. When cooling systems are neglected, they deteriorate very quickly. To restore the cooling system back to its proper performance, you may have to undertake extreme and costly repairs.

The PM responsibility of the cooling system varies from one system to another. On some systems, you will find that the engineering department has the total responsibility of preventive and corrective maintenance. On other systems, you'll find that you, (the ET), share the maintenance responsibility jointly with the engineering department.

In these situations, the ETs would probably perform the preventive maintenance and the engineers would perform the corrective maintenance on major components.

On those cooling skid systems (such as the SPS-49 radar) that are the sole responsibility of the ETs, you will be assigned the responsibility of maintaining the cooling system. Employing both preventive and connective maintenance procedures in accordance with the maintenance requirement cards (MRCs) maximum operation and dependability of the cooling system can be achieved.

## **SUMMARY**

In this chapter, you have been introduced to the various types of cooling systems for electronic equipment. You have studied the function and operation of major components within the liquid cooling system. These topics have provided you with the fundamental knowledge of their operation so that after some hands-on training you can maintain them with confidence. For a more detailed explanation of specific equipment or system, consult the manufacturer's technical manual.

## CHAPTER 2

# DRY AIR SYSTEMS

For optimum performance of today's transmitting equipment, especially high-power radar systems and low-power satellite systems, some rigid coaxial cable and waveguides are required to be pressurized by air. In some waveguide systems, dry air is used primarily to increase the dielectric constant inside the waveguide to prevent rf energy from arcing inside it. Arcing causes damage to the inside of the waveguide, and it also reflects a short circuit back to the power amplifier tube. As a result, the power tube could sustain major damage. Also with the use of pressurized dry air, the problems of corrosion, contamination, collection of moisture, and oil droplets (which affect preservation) are decreased. At the same time, the overall reliability of the waveguide system is increased.

In high-power waveguide runs, the dry air pressure is approximately 20 to 35 psig. The increased air pressure increases the dielectric (resistance) strength of the air. Arcing is then less likely to take place.

In low-power waveguide applications, the dry air is approximately 1 to 8 psig. The dry air is used primarily to prevent corrosion and contamination inside the waveguide. These effects are caused mainly by moisture in the waveguide.

The number of equipments requiring dry air for operation has increased drastically in recent years. Central dry air systems have been installed in many ships to overcome the problems of individual maintenance, repair, and supply support required by individual air dehydrators. There are, however, a large number of individual equipment dehydrators still in use on many ships. They are now being used as a back-up systems should there be a failure in the ship's central air system.

### ELECTRONICS DRY AIR

On ships having multiple dry air users, a dedicated dry air main is installed to support clean, oil free, dry air to pressurized coaxial cables, waveguides, and other electronic equipment. Supply to this main is from the vital main by way of type II or type III dehydrators installed in parallel so that one serves as a 100 percent stand-by for the other. In large ships with extensive air demands, four dehydrators are installed and the air main

can be split for casualty control. The dry air main terminates at air control panels, which control and regulate pressure to the electronic user equipment. Four types of NAVSEA air control panels (type I [user pressure to 30 lb/in<sup>2</sup>], type II [user pressure to 60 lb/in<sup>2</sup>], type III [user pressure of 75 lb/in<sup>2</sup>], and special [usually used where pressure flowrate is unused]) are available.

- Type I Panels: Typical users URA-38, WRT-1 and WRT-2, SPS-39, ULQ-6, WRL-1, SPS-40 waveguides.
- Type II Panels: Typical users SPS-40 cavity, SPG-51 and SPG-60.
- Type III Panels: Typical users require air at 75 lb/in<sup>2</sup> to equipment contained regulators such as SPG-55.
- Special: Typical users SPS-32 and SPS-33, SMQ-10.

In addition, equipment, such as SPS-48 and SPS-49, are supplied with panels designed for 80 to 125 lb/in<sup>2</sup>. Each panel is equipped with a sampling connection, humidity indicator, flow meter, pressure gauges, and associated valves, to permit the user to monitor the equipment.

To ensure the reliability of the dry air supply to the electronic equipment, local dehydrators or local compressor-dehydrators may be provided. These local dehydrators are intended for emergency use when battle damage or casualties result in failure of the central supply system.

Several methods can be employed to remove excess moisture from the air. One method is by freezing the air by means of a refrigerant to remove the moisture. A second method is to pass the air through a desiccant, which absorbs the moisture. Some dehydrators use a combination of both methods to remove moisture from the air.

## CENTRAL DRY-AIR SYSTEM

The ship's central dry-air system is usually located in one of the ship's main engineering spaces and can be composed of a low-pressure (100 psig) air compressor, a Type I dehydrator, and either a Type II or III dehydrator. The air compressor compresses the air and then sends it to the Type I dehydrator (refrigerant). The Type I dehydrator is used to remove the majority of the water and oil in both liquid and gaseous vapor forms from the air. Next, the air is processed by a Type II (desiccant) or a Type III (combination of refrigeration and desiccant) dehydrator to remove the last traces of moisture. This last bit of processing causes the air to become electronic dry.

## DRY-AIR SYSTEMS

If you are involved with an equipment dry-air system, it is essential that you understand how to check the air for sufficient dryness. A high-power waveguide system requires dry air at a pressure of 25 to 35 psig with a dew point of  $-40^{\circ}\text{F}$  at atmospheric pressure.

Dew point is the temperature at which water vapor begins to deposit as a liquid (at atmospheric pressure unless otherwise stated). For example, when the dew point is given as  $40^{\circ}\text{F}$ , this means that the excess moisture in the air will begin to condense at this temperature. Condensation appears as a fog or, if enough moisture is condensed, as ice crystals. The dew point is affected by the pressure of the air being measured. Air at  $40^{\circ}\text{F}$  dew point (atmospheric pressure) contains approximately 120 parts of water per million parts of air (ppm). However, this same air at 30 psig has a dew point of about  $-21^{\circ}\text{F}$ . As you can see, you have to take into account the effects of pressure when you measure the dew point. The lower the dew-point reading (more negative/colder), the better the air quality.

The equipment air dryers installed in electronic equipment are desiccant dryers. The air is passed through a desiccant, which adsorbs the moisture. The more moisture the desiccant adsorbs, the dryer (lower dew point) the air becomes. You should know the basic operation of a desiccant air dryer so that you can perform PM and trouble isolation.

## SHIP'S AIR SUPPLY

Air from the ship's compressor is often contaminated with water and oil in the form of vapor

and liquid. The compressor compresses the air into a smaller volume causing the relative humidity of the air to increase. When the compressed air is saturated (100 percent humidity), it no longer holds any more vapor. Further compression causes the formation of liquid to begin. Also, since most compressors use some form of lubricant, it too can get into the compressed air as a vapor or liquid. The ship's dehydrators can remove all contamination, both liquid and gaseous vapor. In the event of a failure in the central dry air system, the small air dryer (if installed with electronic equipment) can be placed into operation.

## EQUIPMENT DRY AIR

The purpose of the desiccant air dryer (fig. 2-1) is to remove oil and water in both forms, automatically and continuously, and to deliver clean, very dry air for pressurization of equipment waveguides. The air dryer is normally in the bypass mode. In this mode, input air is routed down through the selection valve and out of the dryer by way of the flow limiter. When placing the selection valve so that the dryer will process the air, you must first follow the dryer's start-up procedure.

This procedure ensures that wet air doesn't get into the waveguide systems when the dryer has been shutdown for an extended period. Basically, the procedure involves turning the electrical power on for the dryer and opening/closing of various valves to dump the air to the atmosphere. This is done until the dryer's air monitor indicates that the dew point is below  $40^{\circ}\text{F}$  at atmospheric pressure.

The operation of the air dryer is as follows: the input air (fig. 2-1) (selection valve is indicated) is first checked on the pressure gauge for minimum air pressure (typically 80 psig). Input pressure that is too low inhibits the operation of the fluid separator.

The fluid separator extracts most of the free liquids from the airstream. Some oil and water mist, however, (extremely fine droplets) remain in the stream. The liquid, thus collected, drains into the dump trap below the separator. When a sufficient amount has collected, the trap automatically opens to discharge the collected liquids under pressure into a waste line for disposal.

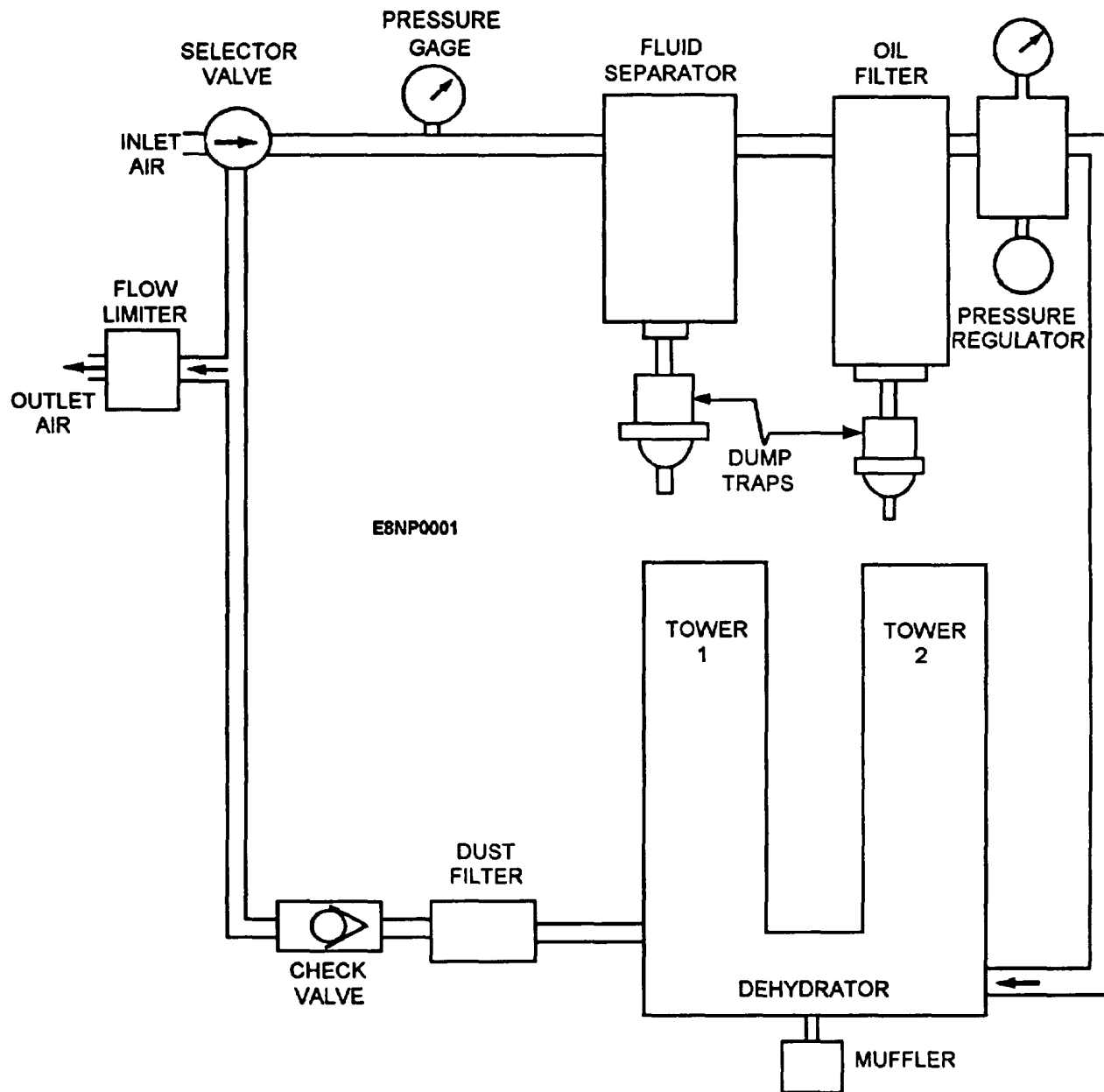


Figure 2-1.-Desiccant air dryer.

After the fluid separator, the air is passed through a telltale oil filter, which removes oil through a combination of mechanical means and absorption. The oil that is removed mechanically drains into a dump trap and is discharged into a waste line as in the fluid separator.

The oil that is absorbed causes the absorbing material to change color from pink to deep red, starting at the bottom, as it becomes saturated. Since the absorbing column is in a transparent plastic tube, the color change is visible. Before the color change reaches

the red line on the column, the absorbing material is discarded and new material is installed.

At this point, liquid oil, liquid water, and some oil vapor have been removed from the air. The air is, in most cases, still saturated with water vapor and still contaminated with oil vapor.

After passing through a pressure regulator, which reduces the air pressure and holds it constant, the wet air passes through the most important unit of the system—the purifier-dehydrator. The purifier-dehydrator performs a cleaning step by a process known

as adsorption There is a difference between absorption and adsorption.

Absorption takes place in the telltale oil filter when it removes oil by soaking it up as a liquid (the same way that a sponge absorbs liquid water into its interior pores).

Adsorption is a surface and a molecular phenomenon. Mobile gaseous and liquid atoms or molecules are attracted to the surface of any solid because of unbalanced forces existing at the surface. Good absorbents are those that present large surfaces per unit and have high attractive forces. One cubic inch of the adsorbent material used in this dryer has an adsorbent area greater than the area of two football fields.

The wet air passes through chambers filled with a molecular sieve type of desiccant, or adsorbing material. Vapor molecules are left behind on the desiccant and the air emerges clean and dry.

The dehydrator has two such chambers through which the air passes alternately. While one chamber is removing vapor from the air, a small portion of the dried air is routed through the second chamber to purge it of all collected vapors and to prepare it to do the drying during the next half cycle.

The reactivation of the desiccant is completely automatic, and unless slugs of entrained water or oil are permitted to enter the desiccant chambers, the material should not be replaced except at major overhaul. The fluid separator and the telltale oil filter, located upstream, prevent slugs of liquid from reaching the desiccant if they are kept in good operating condition.

The dust filter, located downstream from the dehydrator, removes any desiccant or other dust particles that might otherwise be carried along in the dry airstream. At the outlet of the drier unit, a flow limiter is used to prevent the electronic equipment from exceeding the capacity of the dryer. In normal operation, the flowmeter has no effect. However, should an air line or waveguide downstream from the dryer be opened, the flow limiter would prevent an excessive airflow beyond the capability of the dryer.

## DRYER COMPONENTS

In figure 2-1, the placement of the individual components is shown for a typical dryer. This is the order that you should expect to see them. The air dryer is a very reliable piece of equipment and with proper PM can give you years of service.

The operation of the dryer can be bypassed by changing the selector valve. With the selector valve in the position as shown, all air is routed through the dryer.

Starting at the inlet, the individual operation of each major component will be discussed in depth. Let's begin with the fluid separator and its dump trap.

## Fluid Separator and Dump Trap

The fluid separator and dump trap consist of two interconnected assemblies, the separator and the automatic trap, connected together as shown in figure 2-2. The separator itself is a welded metal tank within

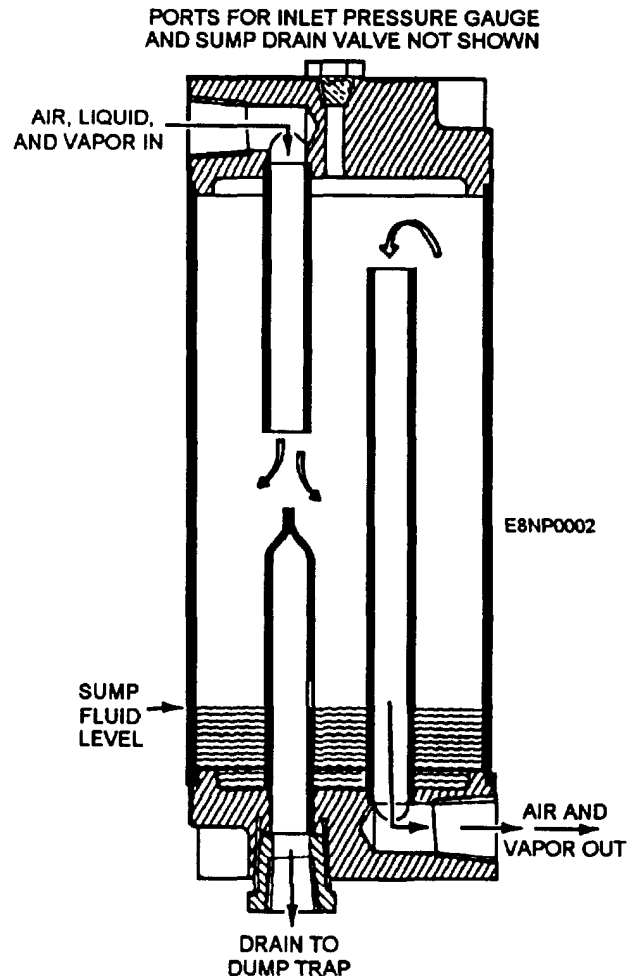


Figure 2-2.—Fluid separator.



and out ports, an inlet pressure gauge, a dump trap, and a sump drain port. There is also a pipe plug located in the top for testing the dump trap.

Air flows through the in-port and a down-coming tube, and is exhausted into the tank. It then reverses its direction, flows upward to the top of the out-port tube, and reverses direction again to reach the Out-port.

Centrifugal forces at the two points of reversal and the slowing of the flow within the tank extract the entrained droplets of liquid. These droplets collect at the bottom of the tank and drain into the dump trap. When the liquid level in the trap rises sufficiently, a float (through a connecting linkage) opens a valve to a waste line, and the collected liquid is blown out. When the float drops, the valve closes and liquid collects until the float automatically initiates another disposal sequence.

Operation of the float maybe observed through a transparent trap bowl. The trap is also equipped with a manual drain, which is operated by pulling a button on the bottom of the trap.

### Telltale Oil Filter and Dump Trap

The telltale oil filter and dump trap are located downstream from the fluid separator and dump trap. It is designed specifically to remove oil from compressed air and to indicate by color the state of the oil removing material. This unit further purifies the air by removing small oil droplets that escape the fluid separator.

As shown in figure 2-3, the filter employs two direction changes of airflow and impingement surfaces to mechanically remove droplets; a mist separator to help small drops become larger and drop out; and an absorbing material to remove the remainder. The absorbing column, which is visible in a transparent tube, changes color from pink to dark red as it absorbs oil. Before the color change reaches a redline indicator, the filter element should be replaced.

Liquid oil drains are collected into an automatic dump trap for discharge into a waste line. This trap is identical to that used on the fluid separator; therefore, the same explanation and comments apply.

The combination of the fluid separator and the telltale oil filter removes entrained water and oil and some of the oil vapor from the supply air, provided that

these units are properly maintained. Water vapor and any remaining oil are removed in the dehydrator (fig. 2-1), which follows further downstream.

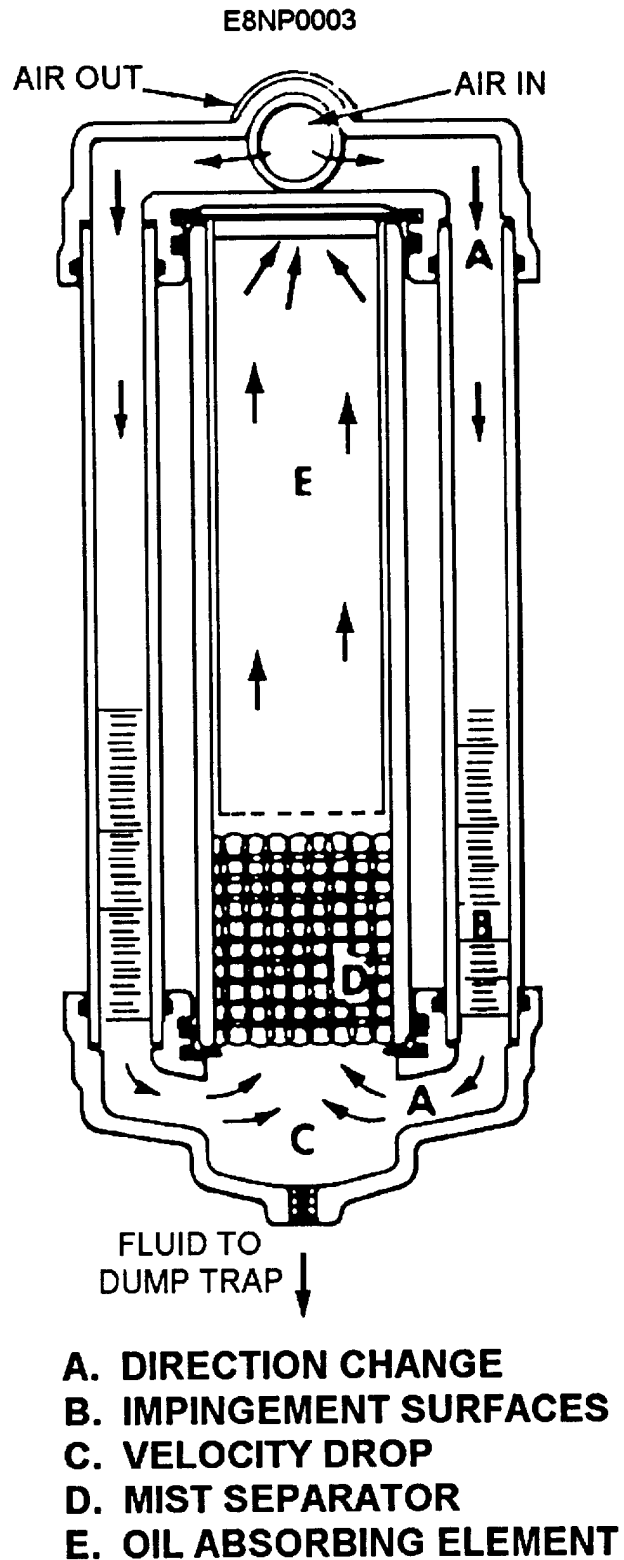


Figure 2-3.-Telltale oil filter.

## Pressure Regulator

The pressure regulator (fig. 2-4) is a diaphragm-operated, pressure-reducing valve located downstream from the fluid separator and telltale oil filter. The diaphragm position governs the valve opening, maintaining a constant reduced output pressure. Compressed air is used to load the diaphragm. This is accomplished by bleeding air from the line through two needle valves, the body needle valve and the dome needle valve, into the air dome. These two needle valves are used to seal off or trap air in the air dome at a pressure approximately equal to the desired outlet pressure. Since the air dome pressure is

approximately equal to desired outlet pressure, a 0- to 100-psig meter is installed, which constantly monitors air dome pressure. This pressure is factory adjusted to 80 psig, which is the inlet pressure to the dehydrator unit.

Since the dome is sealed after loading, a change in temperature will cause a slight change in dome pressure, with a corresponding shift in outlet pressure. This outlet pressure shift amounts to about 1 psig for each 5 degrees Fahrenheit.

The pressure regulator is a balanced pressure regulator that is actuated by static gas pressure in a sealed dome. There is a flexible diaphragm between the

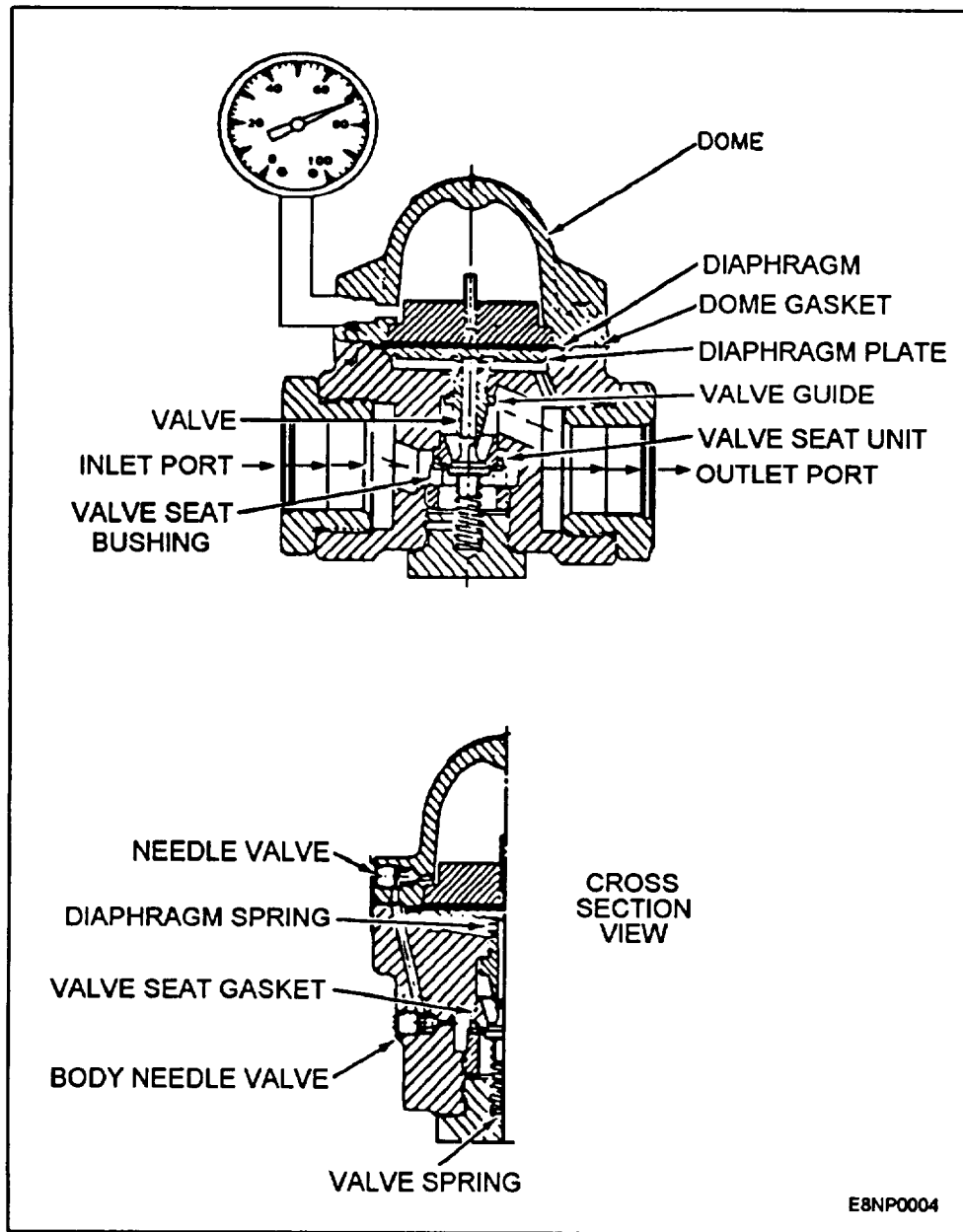


Figure 2-4.-Pressure regulator.

sealed dome and the outlet line fluid. When outlet line pressure drops below dome pressure, the diaphragm moves out slightly and pushes the main valve open. This allows inlet line gas to flow through the valve until outlet line pressure builds up enough to balance the dome pressure. Then, the diaphragm moves back to throttle or closes the main valve so that dome and outlet pressures always remain in balance.

Any change in dome pressure causes a corresponding change in outlet line pressure. When the dome is completely vented, the main valve shuts off bubble tight.

Any trouble with the pressure regulator can usually be traced to the valve and valve seat, or to the diaphragm and O-rings being worn or deteriorated.

### Dehydrator

The dehydrator (fig. 2-5) consists of two desiccant chambers filled with desiccant in the form of small spheres. The desiccant chambers are supported by the manifold, and they are connected to the manifold by

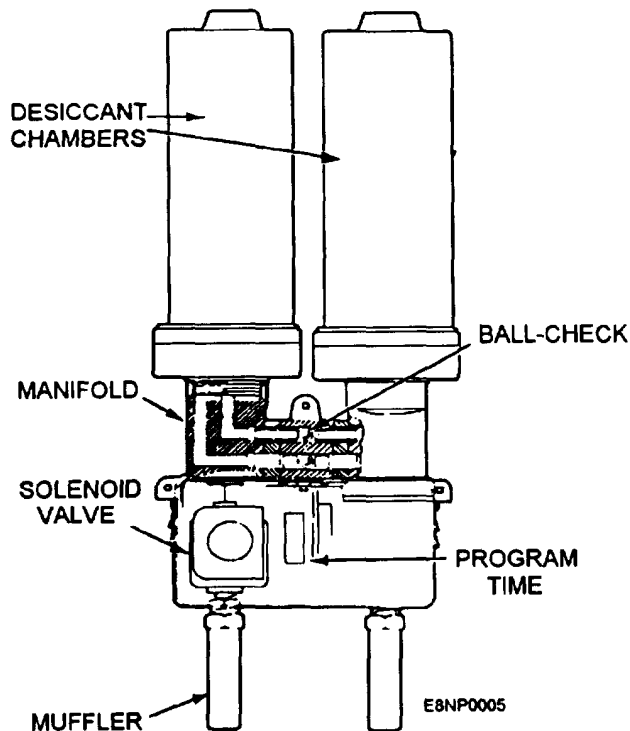


Figure 2-5.—Dehydrator.

internal air passages. A pair of two-way solenoid valves are attached to the bottom side of the manifold.

The program timer controls the operation of the two solenoid valves. In one 60-second period, each solenoid valve is open for 22 seconds and closed for 38 seconds. The timing for the solenoid valves is such that both valves are closed for two 8-second dwell phases. One complete cycle takes place in each desiccant chamber every 60 seconds.

Dry air is needed for reactivation of the desiccant chambers. A small quantity of dry air (figs. 2-5 and 2-6, phase I) is bypassed around the ball-check valve by a

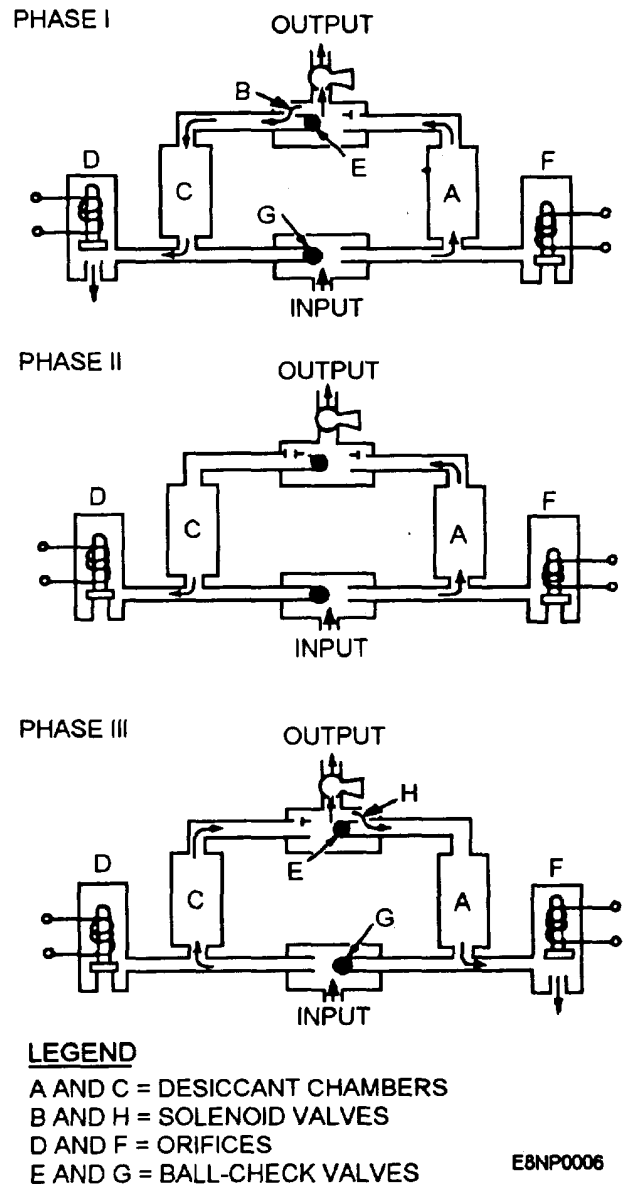


Figure 2-6.—Dehydrator operating cycle.

fixed orifice (B) in the valve body for this purpose. It is expanded to atmospheric pressure through the fixed orifice, which controls the purge airflow. The purge air back flows to atmosphere through each desiccant chamber during half of each cycle. The dry purge air enters the top of the chamber. The oil and water that are removed from the chamber are discharged from the bottom of the chamber through the purge muffler.

The key to the simplicity and unusual efficiency of the dehydrator is its unique valving system. A particular point to notice is that the solenoid control valves handle only the purged air. (The main airflow through the unit does not pass through them as in older units employing three-way valves.) This means that simple, direct-acting, large-orifice, two-way valves can be used to eliminate the sources of high-pressure drops. In addition, this type of valve is more dependable.

Let us take a detailed look at the operation of a dehydrator. We'll consider a complete cycle of operation. Refer to figure 2-6, phases I, II, and III for the following descriptions.

**PHASE I—DRY/PURGE.**— The solenoid valve (F) is closed. Solenoid valve (D) is open. Incoming moist air, under pressure, flows through chamber (A), where it is dried. Most of this dry air is passed through the outlet conduit to be put to use. A small quantity, however, bypasses the closed ball-check valve (E) through a small orifice (B) into chamber (C). Here it picks up moisture from the partially saturated desiccant and passes out of the unit through the open valve (D). Since the chamber being purged is at near-atmospheric pressure, the ball-check valves (E) and (G) are held in place by the pressure of the main airflow.

**PHASE II—DWELL.**— The timer closes both solenoid valves (D) and (F). This allows the pressure in the regenerated chamber (C) to build up through the orifice to approximately that of chamber A.

**PHASE III—DRY/PURGE.**— In figure 2-6 (phase III), the solenoid valve (F) is opened by the timer; solenoid valve (D) remains closed. The pressure in chamber (A) drops immediately, causing the ball-check valves (E) and (G) to move rapidly to the right, sealing off chamber (A) and directing the main airflow through chamber (C) where it is dried. A portion of this dry air, leaking through orifice (H), passes through chamber (A) where it picks up moisture and is emitted to the atmosphere through valve (F). After completing another dwell period, the cycle repeats.

The most important single aspect of maintaining the dehydrator is to assure proper operation of the automatic

dump traps on the fluid separator and the telltale oil filter units. If oil, water, and sludge are not expelled the accumulated liquids may fill the trap, back up into the air lines, and pass into the dehydrator. Complete failure of the desiccant material of the dehydrator to dry and purify quickly follows. If this happens, you will have to completely disassemble and clean the fluid separator, telltale oil filter, both dump traps, the pressure regulator, the dehydrator, and all the interconnecting piping. Also, the desiccant in the dehydrator chambers will have to be replaced.

### Dust Filter

The dust filter (fig. 2-1) consists of a separable housing, which contains a replaceable filter cartridge, constructed of pleated paper (5 microns). The design is such that air flows from the outer (housing) side inward to a hollow center that is connected to the outlet port. Dust is then collected on the outer surface of the filter cartridge. Since the collected dust is dry, any substantial accumulation falls to the bottom of the housing and lessens the possibility of clogging the filter.

### Flow Limiter

A flow limiter (fig. 2-1) is installed between the dust filter and output of the dryer. It is designed to limit the output of the dryer, should the output of air increase beyond the limits of the dryer capability.

The flow limiter is a spring-restrained poppet valve with an orifice in the poppet valve. The poppet valve offers no appreciable resistance to the flow of air during normal operation. When the flow exceeds the design of the dryer, the poppet valve closes, and the flow is then limited by the orifice in the poppet valve.

### MOISTURE MONITOR

A moisture monitor probe is installed downstream from the dryer to monitor the dew point of the dry air. The monitor gives you a visual reading in ppm (parts per million) or in dew point (for example, 40°F). Most monitors have a built-in alarm system. It provides both audible and visual alarms when the air quality is less than the value that it is set to.

When the monitor unit is designed to read the moisture content of the air in dew point, a conversion chart is included with the unit. This chart converts the individual reading to a standard dew-point reading, which is at atmospheric pressure; for example, a dryer feeding three waveguide systems at 10, 20, and 30 psig.

You take a reading of the dew point on the three different waveguide systems and come up with  $-32^{\circ}$ ,  $-25^{\circ}$ , and  $-21^{\circ}\text{F}$ , respectively. Is the last reading of  $-21^{\circ}\text{F}$  a good reading? The radar equipment manual specified  $-25^{\circ}\text{F}$  as the minimum requirement (at atmospheric pressure). Using the dew-point conversion chart, all three of the above readings convert to  $4^{\circ}\text{F}$ , which is well within tolerance for the radar.

The conversion chart is used to convert the individual dew-point reading at various pressures to a known standard.

The sensor probe, which is used to monitor the dry air, consists of an aluminum strip that is anodized by a special process to provide a porous oxide layer. A very thin coating of gold is evaporated over this structure. The aluminum base and the gold layer form the two electrodes of what is essentially an aluminum oxide capacitor. Water vapor is rapidly transported through the gold layer and equilibrates (is in equilibrium) on the pore walls in a manner functionally related to the vapor pressure of water in the atmosphere surrounding the sensor.

The number of water molecules absorbed on the oxide structure determines the conductivity of the pore wall. Each value of pore wall resistance provides a distinct value of electrical impedance; which, in turn, is a direct measure of water vapor pressure.

The monitor unit, as we have indicated, is usually a complex impedance meter. It applies a low-frequency signal of less than 100 Hz to the sensor probe. By measuring the change in this signal amplitude and phase, caused by the sensor probe, the monitor unit continuously computes the impedance of the probe and then displays the value on the unit's meter as the dew point.

Most moisture monitors do not require routine maintenance. If a malfunction should occur, you should isolate the problem by substituting a sensor probe (known to be good). (The sensor is extremely fragile and nothing should touch the aluminum oxide element.) If the problem is isolated to the monitor unit and not the sensor probe, you should use the unit's schematic diagrams and a multimeter to isolate the problem.

## **SUMMARY**

In this chapter, you were given a brief overview of electronics dry air and various types of systems. You have been introduced to a typical shipboard dry air system and its major components: fluid separator, telltale oil filter and dump trap, pressure regulator, dehydrator dust filter, flow limiter, and moisture monitor. These topics have provided you with the fundamental knowledge of their operation so that after some hands-on training you can operate and maintain them with confidence.



# CHAPTER 3

## AC POWER DISTRIBUTION SYSTEM

Almost every function performed aboard a naval ship depends upon electric power for its accomplishment. From the launching of missiles against an aggressive force to baking bread for lunch, electric power is vital to a ship's ability to accomplish its mission.

The ship's service electric plant is equipment that takes the mechanical power of a prime mover and converts it to electrical energy. The prime mover may be driven by steam, gas turbine, diesel, or motor. The mechanical energy of the prime mover is converted to electrical energy in the ship's service generators. These generator sets supply power to the ship's ac power distribution system for further distribution to the various electrical loads throughout the ship.

The ac power distribution system aboard ship consists of the following:

- Ac power plant.
- Switchboards that distribute the power.
- The equipment that consumes the power.

The power distribution system is comprised of the following:

- Ship's service power distribution system.
- Emergency power distribution system.
- Casualty power distribution system.

### ELECTRICAL DISTRIBUTION SYSTEM

The electrical distribution system is the link between the ship's source of electrical power and the ship's electrical loads. Power is normally supplied from the ship's own generators but can be supplied from an external source through the shore power cables.

Most ac power distribution systems in naval ships are 450-volt, three-phase, 60-Hertz, three-wire systems.

Bus ties interconnect the ship's service generator and distribution switchboards so any switchboard can be connected to feed power from the generators to one or more of the other switchboards allowing the generators to operate in parallel.

In large installations (fig. 3-1), power from the generators goes through distribution switchboards or

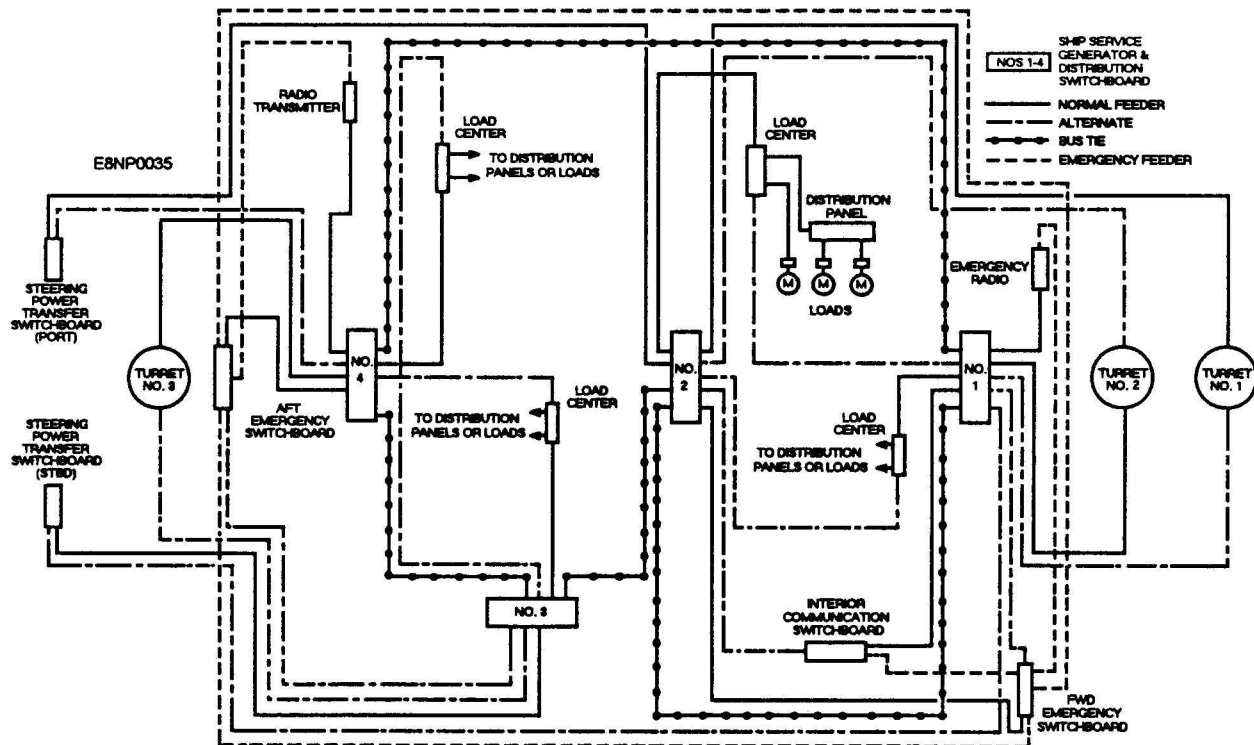


Figure 3-1.-Power distribution in a large combatant ship.

switchgear groups to the load centers, through distribution panels, and on to the loads. Distribution may also be direct from the load centers to some loads.

On some large ships, such as aircraft carriers, a system of zone control of the ship's service and emergency power distribution system is provided. The system sets up several vertical zones that contain one or more load center switchboards supplied through bus feeders from the ship's service switchgear group. A load center switchboard supplies power to the electrical loads within the electrical zone in which it is located. Thus, zone control is provided for all power within the electrical zone. An emergency switchboard may supply more than one zone.

In small installations (fig. 3-2), the distribution panels may or may not be fed directly from the generator

and distribution switchboards. The distribution panels and load centers, if installed, are located centrally with respect to the loads they feed. This arrangement simplifies the installation and requires less weight, space, and equipment than if each load were connected to a switchboard.

### CIRCUIT MARKINGS

All distribution panels and bus transfer equipment have cabinet information plates. These plates contain the following information in the order listed

1. The name of the space, apparatus, or circuits served.
2. The service (power, lighting, electronics) and basic location number.
3. The supply feeder number.

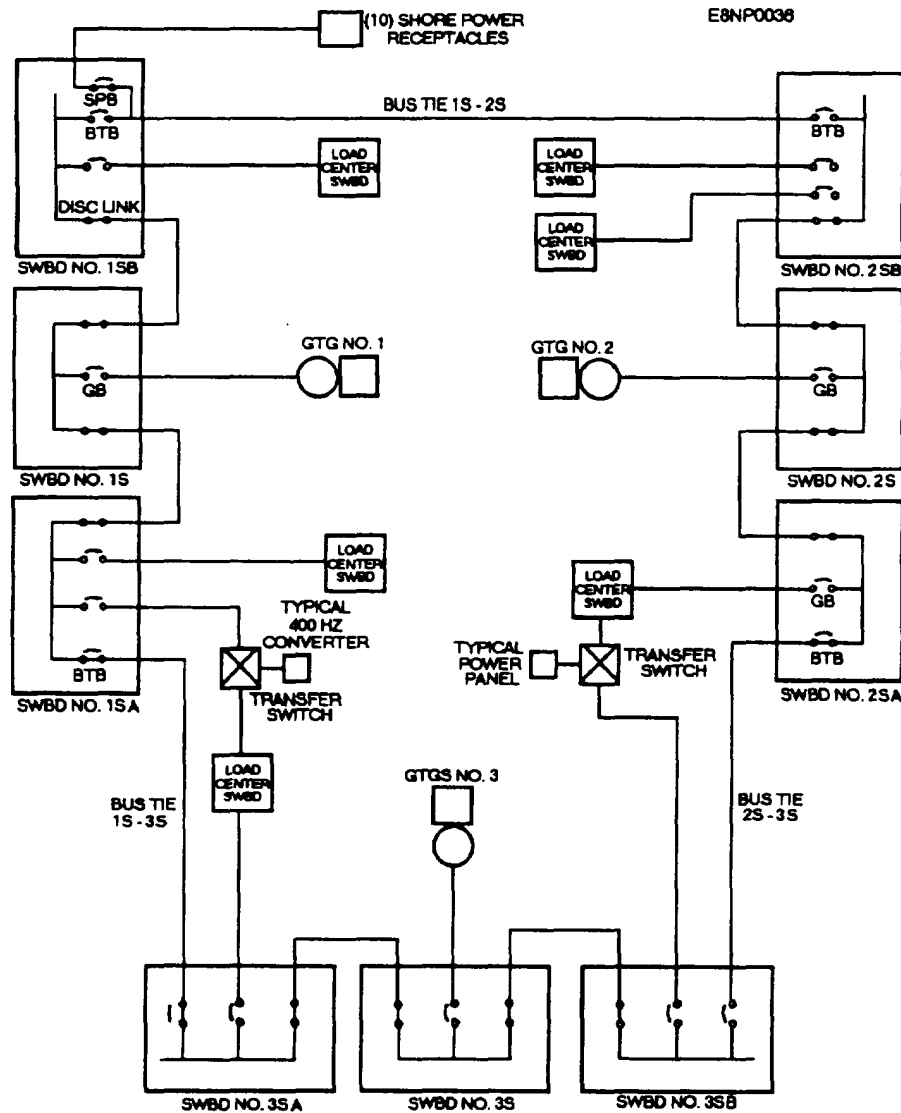


Figure 3-2. Power distribution in a gas-turbine powered DDG.



CREW LIVING SPACE, FRAMES XX - XX  
FIRST PLATFORM  
LIGHTING PANEL 4-108-2  
2S-4L-(4-103-2)

If a panel contains two or more sets of buses and each set is supplied by a separate feeder, the number of each feeder will be indicated on the identification plate.

Distribution panels have circuit information plates next to the handle of each circuit breaker or switch. These plates contain the following information in the order listed:

1. The circuit number.
2. The name of the apparatus or circuit controlled.
3. The location of the apparatus or space served.
4. The circuit breaker element or fuse rating.

Vital circuits are shown by red markers attached to circuit information plates. Information plates for circuit breakers supplying circle W and circle Z class ventilation systems contain, in addition to the red marker, the class designation of the ventilation system supplied. Information plates without markings are provided for spare circuit breakers mounted in distribution panels. Panel switches controlling circuits that are de-energized during darkened ship operations are marked DARKENED SHIP. The ON and OFF position of these switches are marked LIGHT SHIP and DARKENED SHIP, respectively.

Circuit information plates are provided inside fuse boxes (next to each set of the fuses). They show the circuit controlled, the phases or polarity, and the ampere rating of the fuse.

## PHASE SEQUENCE

The phase sequence in naval ships is ABC; that is, the maximum positive voltages on the three phases are reached in the order A, B, and C (fig. 3-3). Phase sequence determines the direction of rotation of three-phase motors. Therefore, a reversal of the phase sequence could cause damage to loads, especially pumps, driven by three-phase motors. The phase sequence of the power supply throughout a ship is always ABC (regardless of whether power is supplied from any of the switchboards or from the shore power connection) to ensure that three-phase, ac motors will always run in the correct direction.

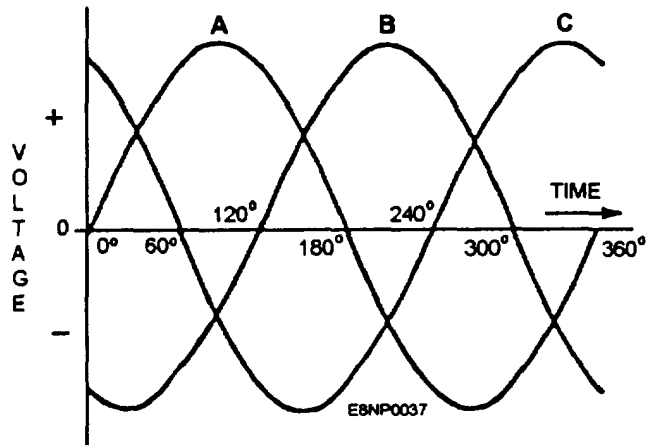


Figure 3-3.-Sine curve for three-phase circuit.

Phase identification is denoted by the letters A, B, and C in a three-phase system. Switchboard and distribution panel bus bars and terminals on the back of switchboards are marked to identify the phase with the appropriate letters, A, B, or C. The standard arrangement of phases in power and lighting switchboards, distribution panels, feeder distribution boxes, feeder junction boxes, and feeder connection boxes is in the order A, B, and C from top to bottom, front to back or right to left when facing the front of the switchboard, panel, or box, and left to right when facing the rear of the switchboard, panel, or box.

## BUS TRANSFER SWITCHES

Bus transfer equipment is used to provide two sources of power to equipment that is vital to the ship. This vital equipment is that equipment needed to operate safely or could cause the ship to become disabled if it becomes de-energized.

Depending upon the application, the transfer from one source to another may be done manually, by a manual bus transfer switch, or automatically by an automatic bus transfer switch.

### MANUAL BUS TRANSFER (MBT) SWITCHES

When normal power to vital equipment is lost, power must be restored as soon as possible to ensure the safety of the ship. MBTs may be used to switch from normal to alternate or emergency power for those loads that draw a large starting current or for which some condition must be met before energizing. A good example of this would be HF radio equipment, if power would be automatically reapplied after a sudden loss, major damage would occur to the transmitter.

After a sudden loss of power, having a manual transfer of the power source will ensure all conditions are met before energizing the equipment. (See figure 3-4.)

### AUTOMATIC BUS TRANSFER (ABT) SWITCHES

ABTs are used to provide two sources of power to those loads that MUST be re-energized as soon as possible after a sudden loss of normal power. Some examples would be lighting in main engineering spaces, ship's steering motors and controls, motor-driven fuel pumps, and lubricating oil pumps.

### SHIP'S SERVICE SWITCHBOARDS

Aboard modern Navy vessels there are three distinct groups or shipsets of distribution switchboards. A shipset of main power distribution switchboards

consists of three groups, each group being comprised of three units. Figures 3-5 to 3-7 show the switchboards that comprise shipset 1S.

The units, physically separated and connected by cables, form a switchgear group. This physical separation of sections provides greater protection from damage since it is less likely more than one unit can be damaged by one hit in battle. It also provides a means for removing a damaged section for repairs or replacement.

Switchboards provide three distinct functions aboard ship:

- Distribution of 450-volt, 3-phase, 60-Hz power
- Protection of distribution circuits
- Control, monitoring, and protection of the generator sets

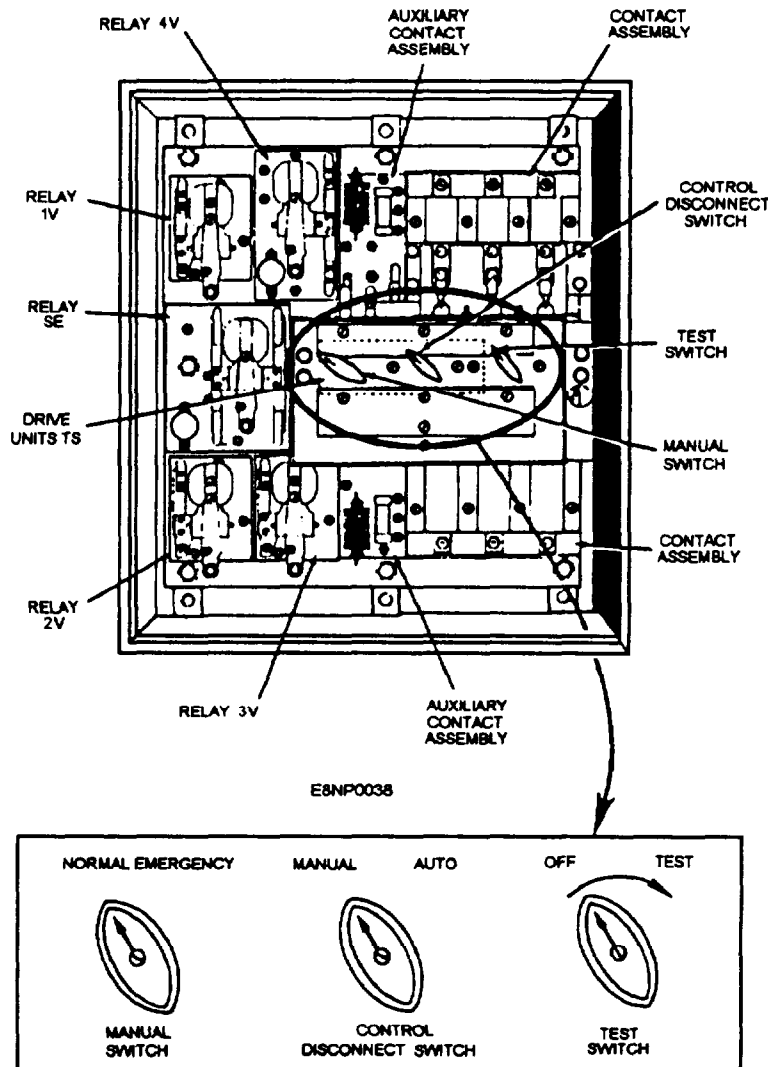


Figure 3-4.-A pictorial view of the A-2 ABT.

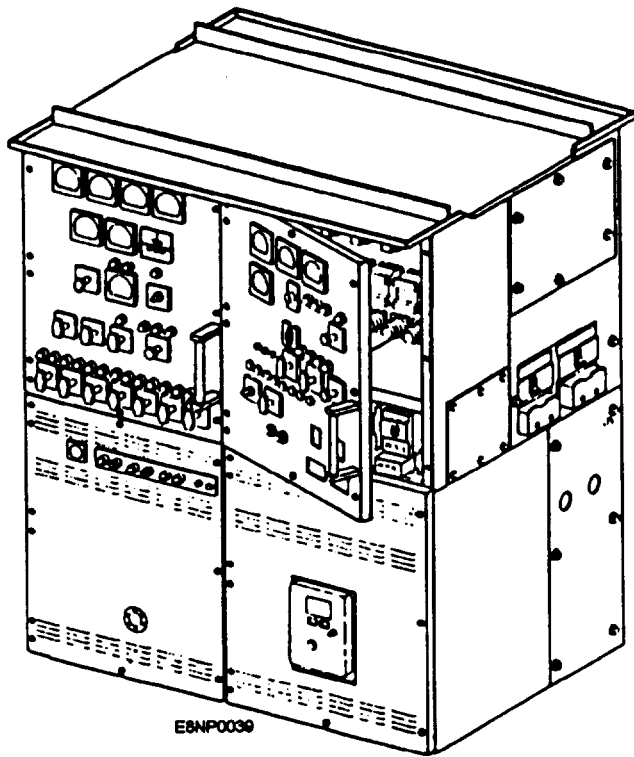


Figure 3-5.-1S ship's service switchboard.

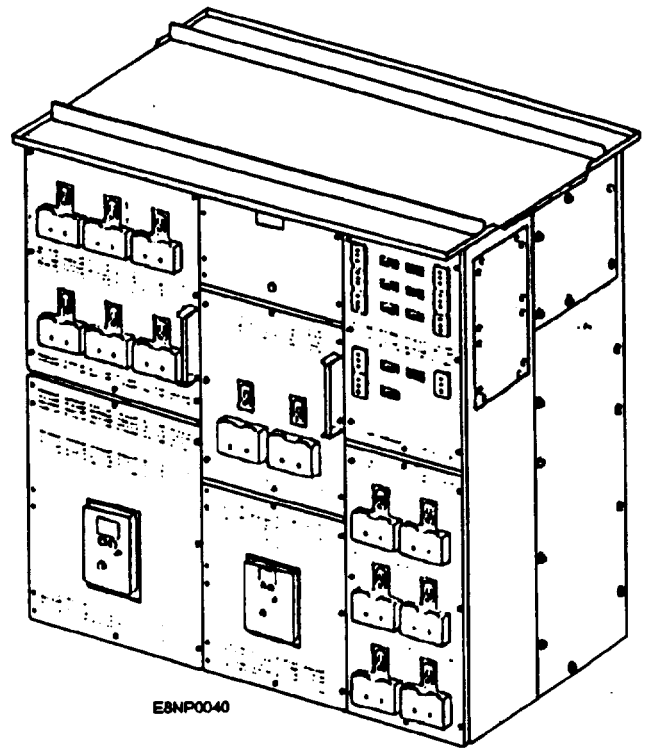


Figure 3-6.-1SA Ship's switchboard.

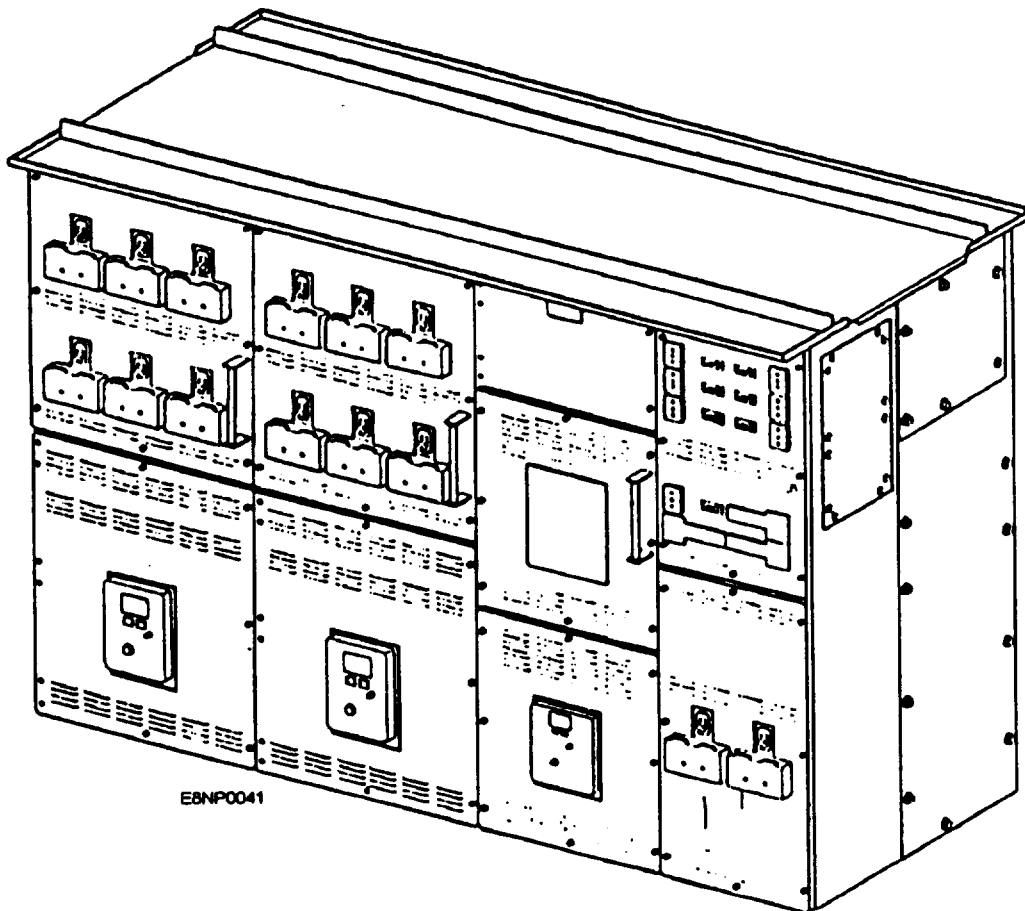


Figure 3-7.-1SB ship's service switchboard.

## CAPABILITIES

Each switchboard group is an operationally independent system, capable of monitoring and controlling an associated generator.

Operated as an independent system, a switchboard is capable of distributing the power produced by the associated generator to equipment and zones fed by the switchboard bus. Operated in parallel with either one or both of the other groups, power can be supplied to the entire ship service load.

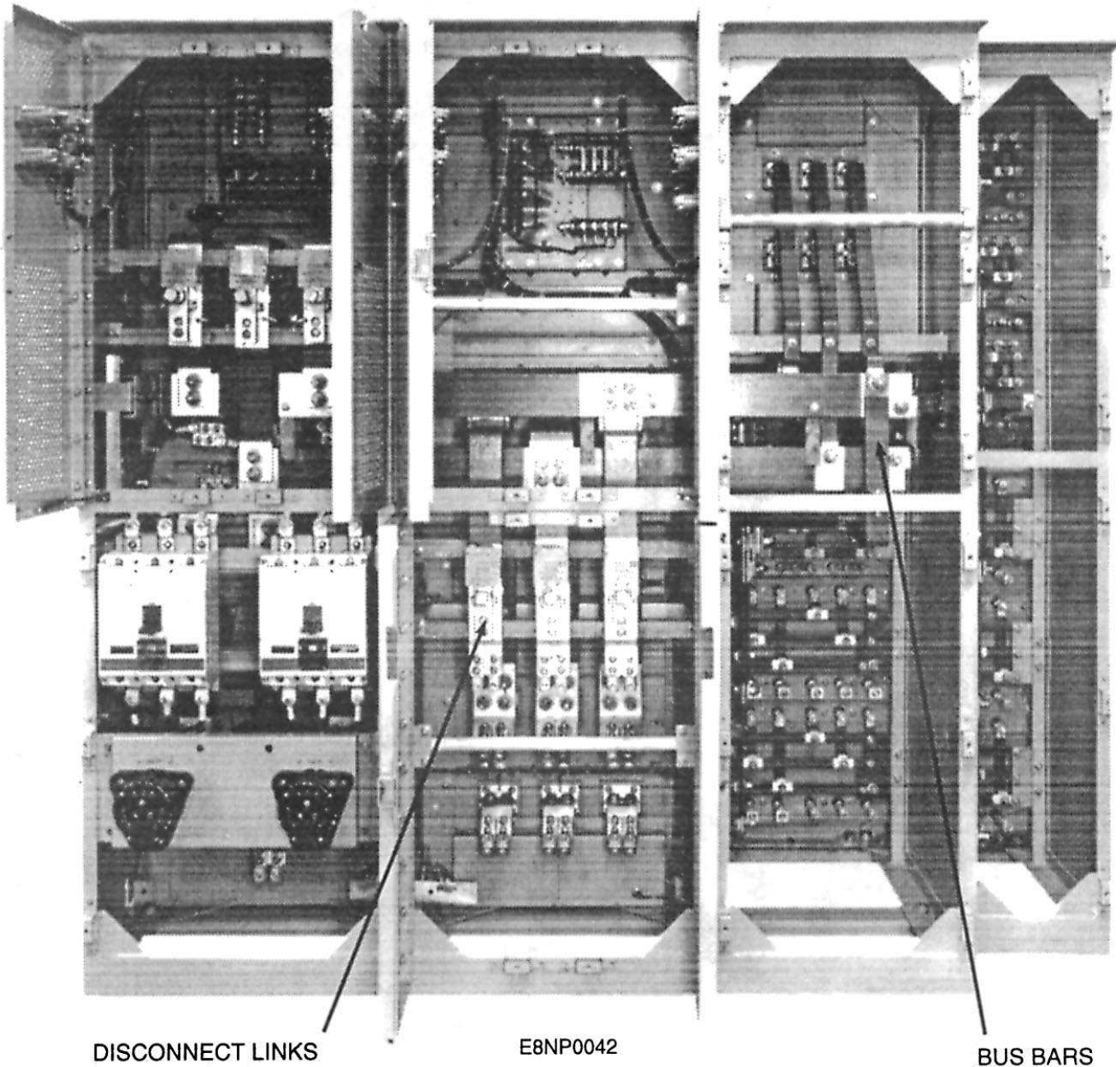
## DESCRIPTION

Power is produced by the generators, input to the switchboards through the generator circuit breakers,

and distributed to the various ship's loads via feeder breakers and load centers.

Control and monitoring of the ship's service power is accomplished by the various manual, remote, and automatic control functions associated with the switchboards. In addition, the metering and indications used to maintain proper power plant performance give the electrician on watch the status of the power plant at any given time.

The distribution system is protected from damage by the various mechanical and electrical devices used to interrupt the flow of electricity, either by command or automatically, should a problem arise.



DISCONNECT LINKS

E8NP0042

BUS BARS

**Figure 3-8.-Rear view of a switchboard showing bus bars and disconnect links.**

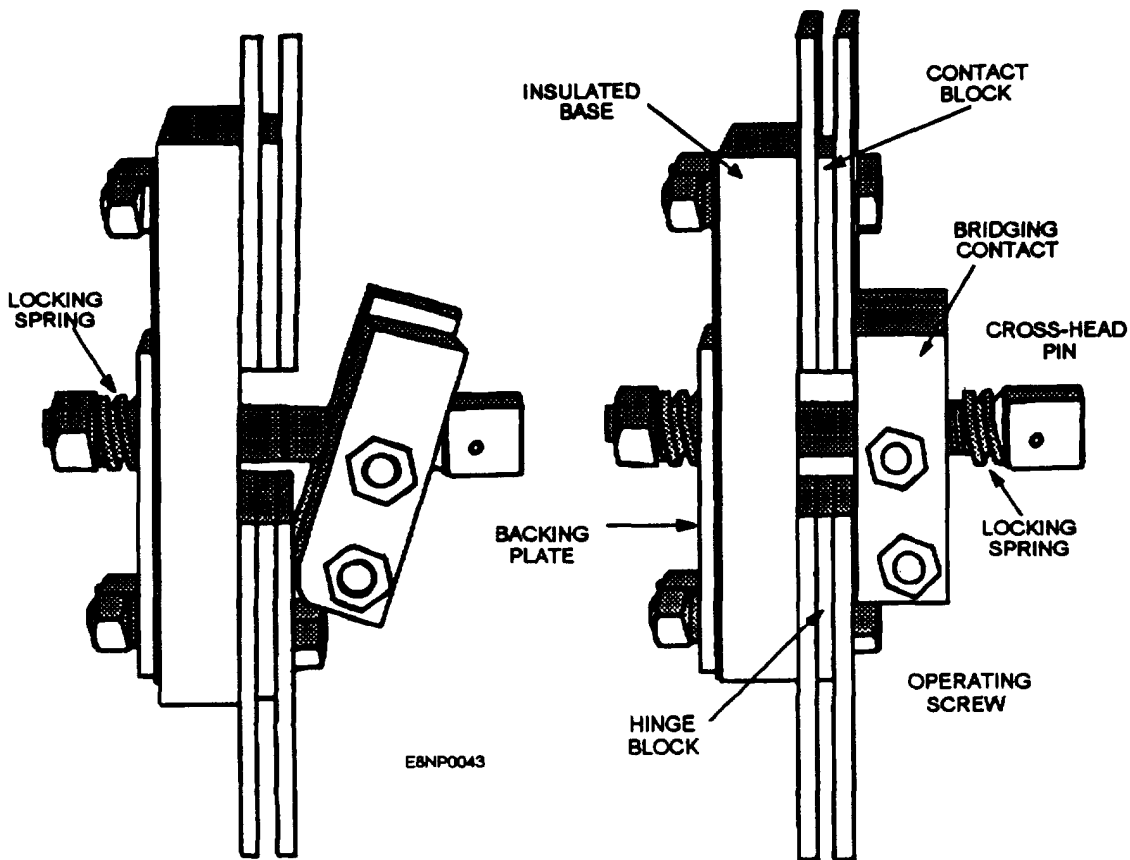


Figure 3-9.-Disconnect links.

The switchboards shown in figures 3-5, 3-6, and 3-7 are representative of the found on most gas-turbine powered ships today. These switchboards use sheet steel panels or enclosures from which only the meters and the operating handles protrude to the front. Distribution of the generated power begins with the switchboard. These switchboards can be connected together through bus tie circuit breakers to form a continuous loop. This allows any two of the three gas turbine generator sets (GTGS's) to supply the demand for power, while the third can be set up to start automatically in the event of a power loss. (See figure 3-8.)

Each of the switchboard units of a group are connected together through disconnect links (fig. 3-9). By removing the links between any two of the switchboards, repairs or replacement of parts may be accomplished without interfering with the operation of the other units.

### GROUND DETECTOR CIRCUITS

A set of three ground detector lamps (fig. 3-10) is connected through transformers to the main bus of each ship's service switchgear group. It provides you with a

means to check for grounds on any phase of the three-phase system.

To check for a ground, turn switch S on and observe the brilliancy of the three lights. If the lights are equally bright, all lights are receiving the same voltage, and no ground exists. If lamp A is dark and lamps B and C are bright, phase A is grounded. In this case, the primary of the transformer in phase A is shunted to ground, and lamp A receives no voltage. Similarly, if lamp B is dark and lamps A and C are bright a ground exists on phase B. If lamp C is dark and lamps A and B are bright, a ground exists on phase C.

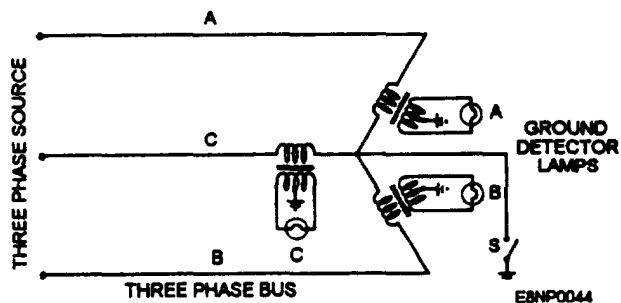


Figure 3-10.-An ac ground detector lamp circuit.

## AC GENERATORS

Alternating-current generators produce most electric power used today. Ac generators are also used in aircraft and automobiles.

Ac generators come in many different sizes, depending on their intended use. For example, any one of the huge generators at Boulder Dam can produce millions of volt-amperes, while the small generators used on aircraft produce only a few thousand volt-amperes.

Regardless of their size, all generators operate on the same basic principle—a magnetic field cutting through conductors, or conductors passing through a magnetic field.

All generators have at least two distinct sets of conductors:

A group of conductors in which the output voltage is generated known as the *armature winding*.

A second group of conductors through which direct current is passed to obtain an electromagnetic field of fixed polarity known as the *field winding*.

Since relative motion is needed between the armature and field flux, ac generators are built in two major assemblies—the stator and the rotor (fig. 3-11).

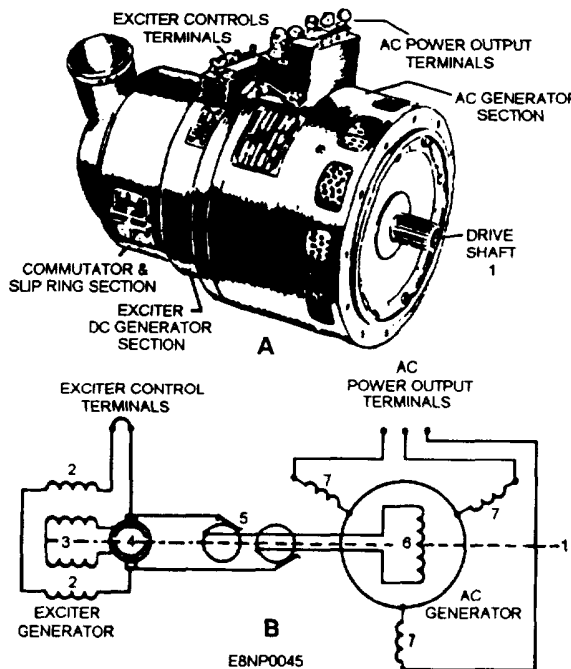


Figure 3-11.—An ac generator and schematic.

The rotor rotates inside the stator. It is driven by several commonly used power sources: gas or steam turbines, electric motors, and internal-combustion engines.

## THREE-PHASE GENERATORS

A three-phase ac generator, as the name implies, has three single-phase windings spaced so that the voltage induced in each winding is  $120^\circ$  out of phase with the voltages in the other two windings. A schematic diagram of a three-phase stator showing all the coils becomes complex, and it is difficult to see what is actually happening. A simplified schematic diagram showing all the windings of a single phase lumped together as one winding is illustrated in figure 3-12, view A. The rotor is omitted for simplicity. The waveforms of voltage are shown to the right of the schematic. The three voltages are  $120^\circ$  apart and are similar to the voltages that would be generated by three single-phase ac generators whose voltages are out of phase by angles of  $120^\circ$ . The three phases are independent of each other.

### Wye Connection

Rather than have six leads come out of the three-phase ac generator, one of the leads from each phase may be connected to form a common junction. The stator is then said to be wye, or star, connected. The common lead may or may not be brought out of the machine. If it is brought out, it is called the neutral. The simplified schematic (fig. 3-12, view B) shows a wye-connected stator with the common lead not brought out. Each load is connected across two phases in series.  $R_{AB}$  is connected across phases A and B in series;  $R_{AC}$  is connected across phases A and C in series; and  $R_{BC}$

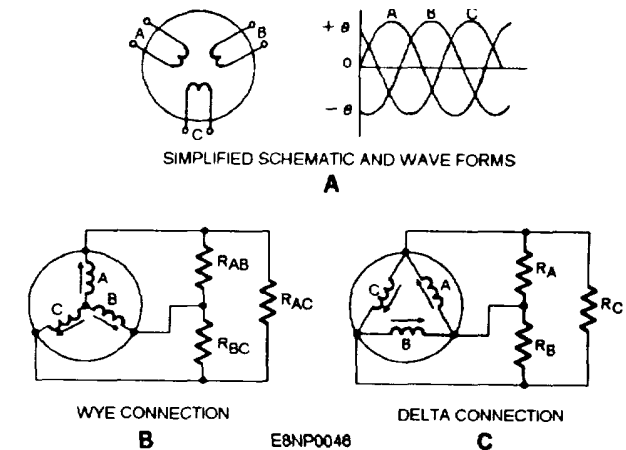


Figure 3-12.—Three-phase ac generator: A. Simplified schematic and wave forms; B. Wye connection; C. Delta connection.

is connected across phases B and C in series. Thus, the voltage across each load is larger than the voltage across a single phase. In a wye-connected ac generator, the three start ends of each single-phase winding are connected together to a common neutral point and the opposite, or finish, ends are connected to the line terminals, A, B, and C. These letters are always used to designate the three phases of a three-phase system, or the three line wires to which the ac generator phases connect.

A three-phase, wye-connected ac generator supplying three separate loads is shown in figure 3-13. When unbalanced loads are used, a neutral may be added as shown in the figure by the broken line between the common neutral point and the loads. The neutral wire serves as a common return circuit for all three phases and maintains a voltage balance across the loads. No current flows in the neutral wire when the loads are balanced. This system is a three-phase, four-wire circuit and is used to distribute three-phase power to shorebased installations. The three-phase, four-wire system is not used aboard ship, but it is widely used in industry and in aircraft ac power systems.

### Delta Connection

A three-phase stator may also be connected as shown in figure 3-12, view C. This is called the delta connection. In a delta-connected ac generator, the start end of one phase winding is connected to the finish end of the third; the start of the third phase winding is connected to the finish of the second phase winding; and the start of the second phase winding is connected to the finish of the first phase winding. The three junction points are connected to the line wires leading to the load.

A three-phase, delta-connected, ac generator is depicted in figure 3-14. The generator is connected to a three-phase, three-wire circuit, which supplies a three-phase, delta-connected load at the right-hand end of the three-phase line. Because the phases are connected directly across the line wires, phase voltage

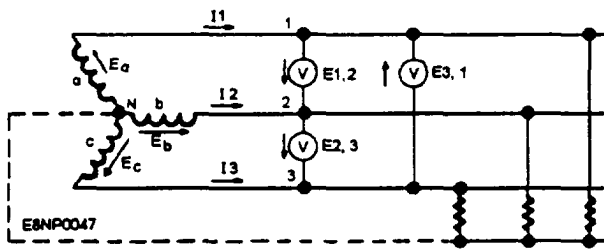


Figure 3-13.—Three-phase ac generator showing neutral connection.

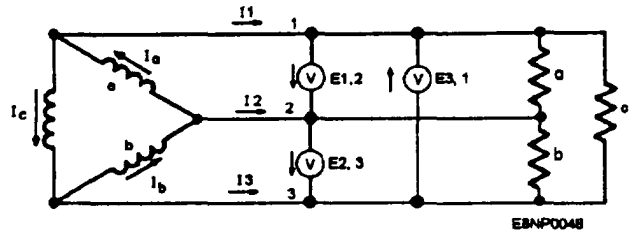


Figure 3-14.—Three-phase, delta-connected system.

is equal to line voltage. When the generator phases are properly connected in delta, no appreciable current flows within the delta loop when there is no external load connected to the generator. If anyone of the phases is reversed with respect to its correct connection, a short-circuit current flows within the windings of no load, causing damage to the windings.

## TRANSFORMERS

A transformer is a device that has no moving parts and that transfers energy from one circuit to another by electromagnetic induction. The energy is always transferred without a change in frequency, but usually with changes in voltage and current. A step-up transformer receives electrical energy at one voltage and delivers it at a higher voltage. Conversely, a step-down transformer receives energy at one voltage and delivers it at a lower voltage. Transformers require little care and maintenance because of their simple, rugged, and durable construction. The efficiency of transformers is high. Because of this, transformers are responsible for the more extensive use of alternating current than direct current. The conventional constant-potential transformer is designed to operate with the primary connected across a constant-potential source and to provide a secondary voltage that is substantially constant from no load to full load.

Various types of small, single-phase transformers are used in electrical equipment. In many installations, transformers are used on switchboards to step down the voltage for indicating lights. Low-voltage transformers are included in some motor control panels to supply control circuits or to operate overload relays.

Instrument transformers include potential, or voltage, transformers and current transformers. Instrument transformers are commonly used with ac instruments when high voltages or large currents are to be measured.

Electronic circuits and devices employ many types of transformers to provide the necessary voltages for proper circuit operation, interstage coupling, signal amplification, and so forth. The physical construction of these transformers differs widely.

Power-supply transformers, used in electronic circuits, are single-phase, constant-potential transformers with either one or more secondary windings, or a single secondary with several tap connections. These transformers have a low volt-ampere capacity and are less efficient than large constant-potential power transformers. Most power-supply transformers for electronic equipment are designed to operate at a frequency of 50 to 60 Hz. Aircraft power-supply transformers are designed for a frequency of 400 Hz. The higher frequencies permit a saving in size and weight of transformers and associated equipment.

The typical transformer has two windings insulated electrically from each other. These windings are wound

Table 3-1.-Principle Parts of a Transformer

<u>Piece</u>	<u>Function</u>
Core	Provides a path for the magnetic lines of flux
Primary winding	Receives the energy from the ac source
Secondary winding	Receives energy from the primary winding and delivers it to the load
Enclosure	Protects the above components from dirt, moisture, and mechanical damage

on a common magnetic core made of laminated sheet steel. The principal parts of a transformer and their functions are given in table 3-1.

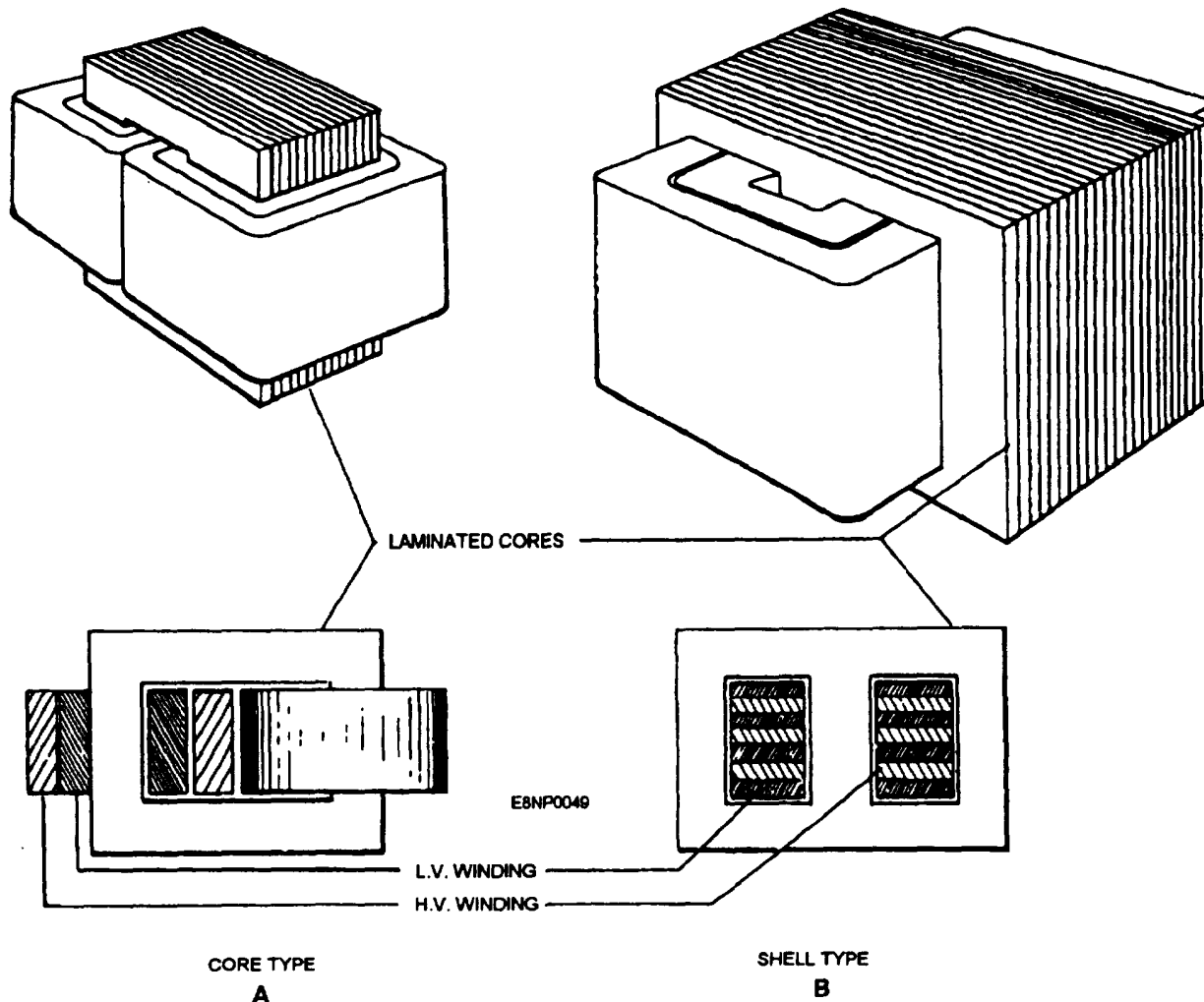


Figure 3-15.-Types of transformer construction: A. Core type; B. Shell type.



When a transformer is used to step up the voltage, the low-voltage winding is the primary. Conversely, when a transformer is used to step down the voltage, the high-voltage winding is the primary. The primary is always connected to the source of the power; the secondary is always connected to the load. A common practice is to refer to the windings as the primary and secondary rather than the high-voltage and low-voltage windings.

Two principal types of transformer construction are the core type and the shell type (fig. 3-15, views A and B). The cores are built of thin stamping of silicon steel. Eddy currents, generated in the core by the alternating flux as it cuts through the iron, are minimized by using thin laminations and by insulating adjacent laminations with insulating varnish. Hysteresis losses, caused by the friction developed between magnetic particles as they are rotated through each cycle of magnetization, are minimized by the use of a special grade of heat-treated, grain-oriented, silicon-steel laminations.

In the core type of transformer, copper windings surround the laminated iron core. In the

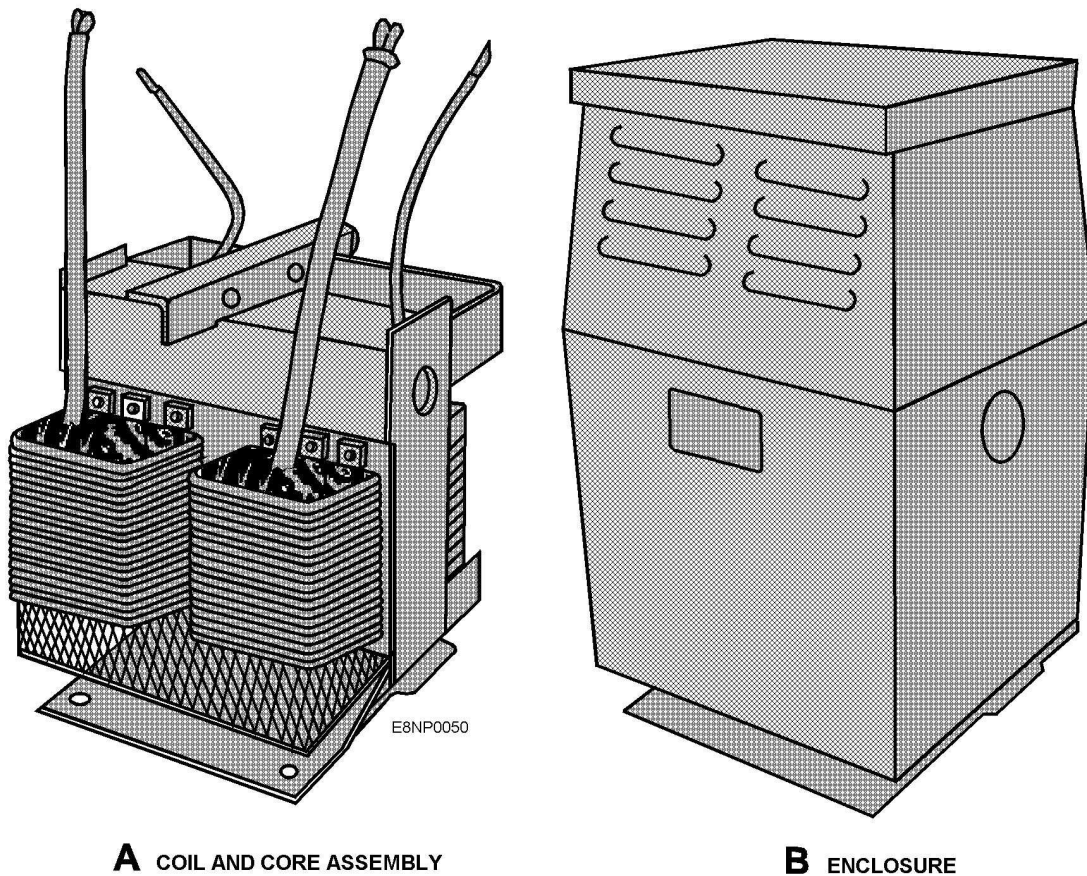
shell-type of transformer, an iron core surrounds the copper windings. Distribution transformers are generally of the core type, whereas some of the largest power transformers are of the shell type.

Transformers are built in both single-phase and polyphase units (fig. 3-16). A three-phase transformer consists of separate insulated windings for the different phases, which are wound on a three-legged core capable of establishing three magnetic fluxes displaced 120° in time phase.

### **POLARITY MARKING OF POWER TRANSFORMERS**

It is essential that all transformer windings be properly connected and that you have a basic understanding of the coding and the marking of transformer leads.

The leads of large power transformers, such as those used for lighting and public utilities, are marked with numbers, letters, or a combination of both. This type of



**Figure 3-16.-Single-phase transformer A. Coil and core assembly B. Enclosure.**

marking is shown in figure 3-17. Terminals for the high-voltage windings are marked H1, H2, H3, and so forth. The increasing numerical subscript designates an increasing voltage, denoting a higher voltage between H1 and H3 than the voltage between H1 and H2.

The secondary terminals are marked X1, X2, X3, and so forth. Two types of markings maybe employed on the secondaries. When the H1 and X1 leads are brought out on the same side of the transformer (fig. 3-17, view A), the polarity is called subtractive. The reason this arrangement is called subtractive is if H1 and X1 leads are connected and a reduced voltage is applied across the H1 and H2 leads, the resultant voltage that appears across the H2 and X2 leads in the series circuit formed by this connection will equal the difference in the voltages of the two windings. The voltage of the low-voltage winding opposes the high-voltage winding and subtracts from it; hence the term, *subtractive polarity*.

When the H1 and X1 leads are brought out on opposite corners of the transformer (fig. 3-17, view B), the polarity is additive. If the H1 and X2 leads are connected and a reduced voltage is applied across the H1 and H2 leads, the resultant voltage across the H2 and X1 leads in the series circuit formed by this connection will equal the sum of the voltages of the two windings. The voltage of the low-voltage winding aids the voltage of the high-voltage winding and adds to it, hence the term, *additive polarity*.

Polarity markings do not indicate the internal voltage stress in the windings. They are useful; only in making external connections between transformers.

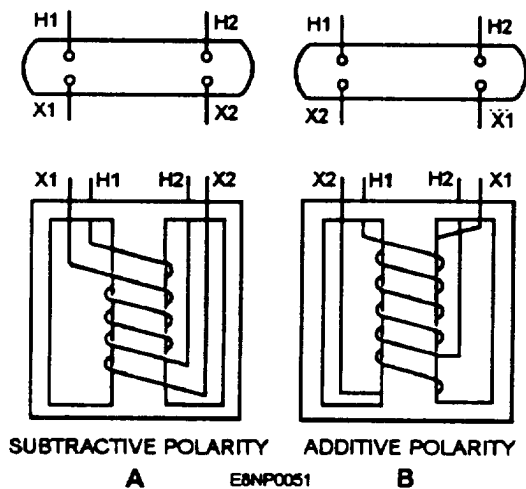


Figure 3-17.-Polarity markings for large transformers: A. Subtractive polarity; B. Additive polarity.

## 400-HERTZ POWER DISTRIBUTION

In addition to the 60-Hz power supplied by the ship's service generators, ships also have 400-Hz systems. On some ships 400-Hz power is generated by motor-generator sets and distributed via special frequency switchboards (fig. 3-18) to the various 400-Hz equipment.

These motor generators supply power to ship's service special frequency switchboards. Figure 3-19 is a simplified line diagram of the 400-Hz ship's service bus tie interconnections on an older ship. The circuits being fed from the 400-Hz ship's service switchboards are deleted from the figure for simplicity.

Newer ships get their supply of 400-Hz power through the use of 60/400-Hz static converters. The 400-Hz system consists of four MBT's supplying 60-Hz power to four 60/400-Hz static frequency converters

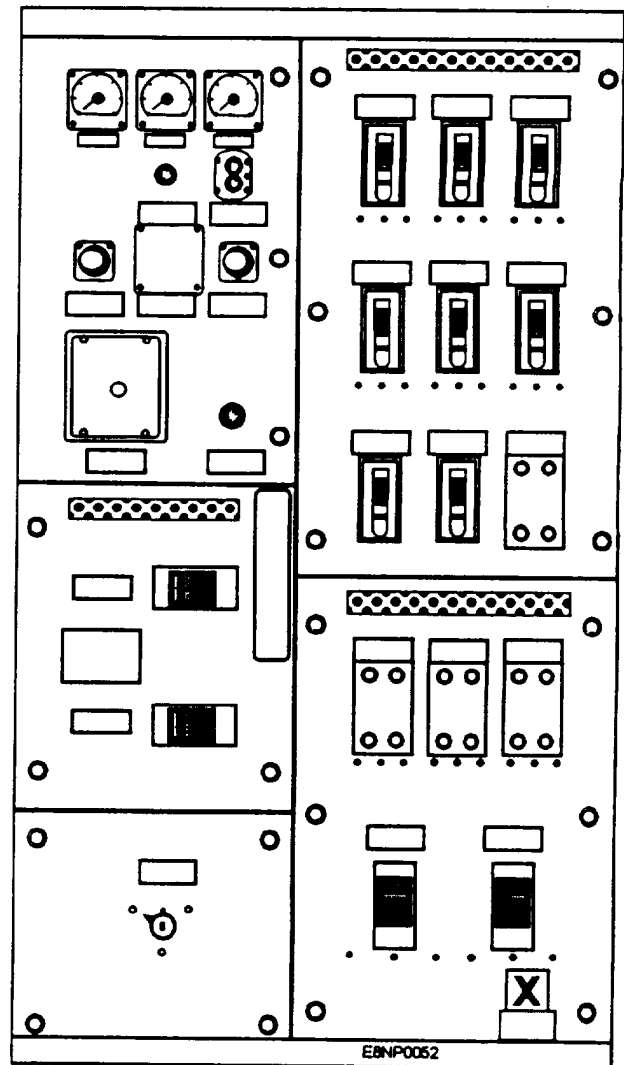


Figure 3-18.-400-Hz switchboard.

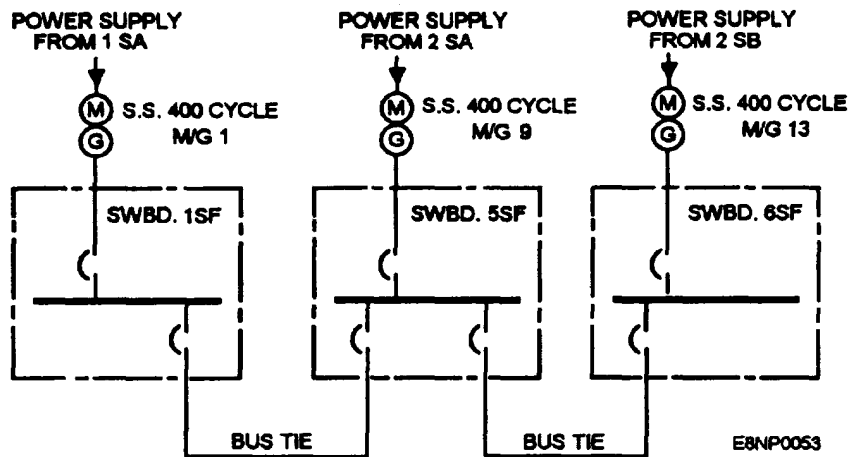


Figure 3-19.-Bus tie connections on 400-Hz ship's service system.

(STC 1 thru STC 4). Each is rated at 150 KW at 0.8 power factor (fig. 3-20) and distributed to 400 Hz loads through two distribution switchboards, designated 1SF and 2SF.

Both distribution switchboards provide for centralized distribution of 450-volt, three-phase, 400-Hz power. Each switchboard is also capable of controlling and monitoring converter input, converter output, and bus tie circuit breakers.

### CASUALTY POWER DISTRIBUTION SYSTEM

Damage to ship's service and emergency distribution systems in wartime led to the development

of the casualty power system. This system provides the means for making temporary connections to vital circuits and equipment. The casualty power distribution system is limited to those facilities necessary to keep the ship afloat and permit it to get out of the danger area. It also provides a limited amount of armament, such as weapons systems and their directors.

Optimum continuity of service is ensured in ships provided with ship's service, emergency, and casualty power distribution systems. If one generating plant should fail, a remote switchboard can be connected by the bus tie to supply power from the generator or generators that have not failed

If a circuit or switchboard fails, the vital loads can be transferred to an alternate feeder and source of ship's

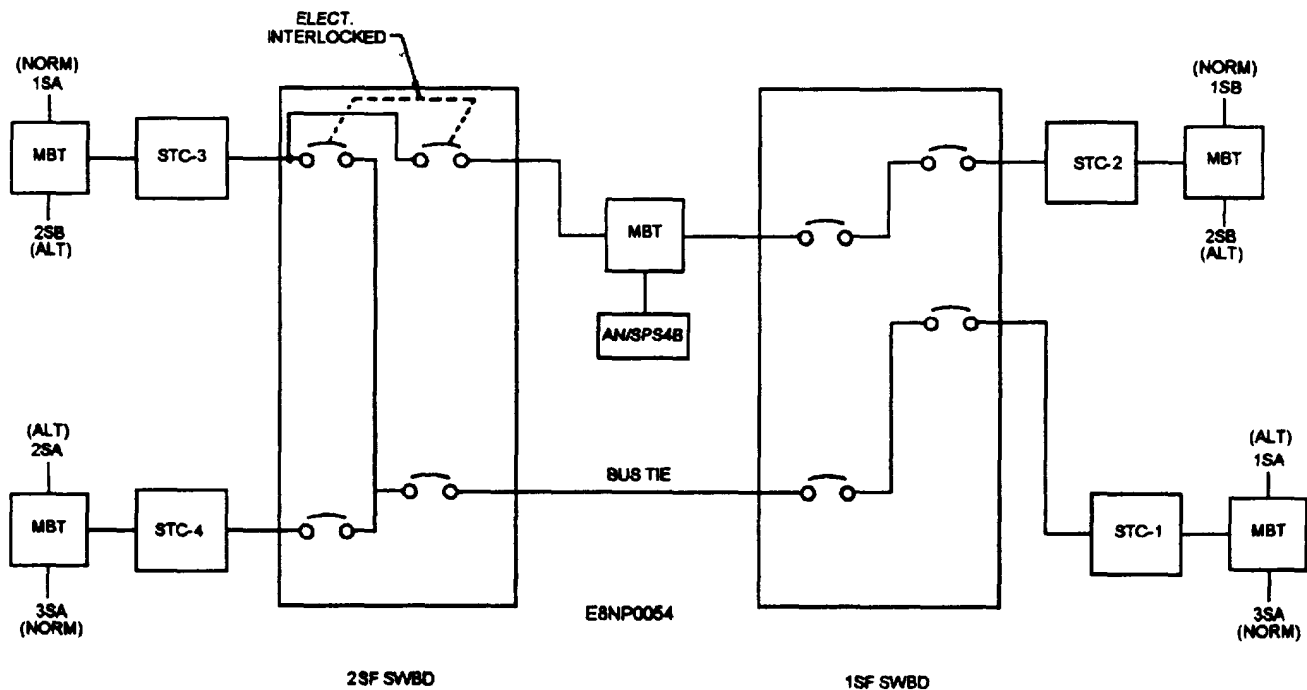


Figure 3-20.-400-Hz electric power distribution system.

service power by means of a transfer switch near the load.

If both the normal and alternate sources of the ship's service power fail because of a generator, switchboard, or feeder casualty, the vital auxiliaries can be shifted to an emergency feeder that receives power from the emergency switchboard.

If the ship's service and emergency circuits fail, temporary circuits can be rigged with the casualty power distribution system and used to supply power to vital auxiliaries if any of the ship's service or emergency generators can be operated. The casualty power system includes suitable lengths of portable cable stowed on racks throughout the ship. Permanently installed casualty power bulkhead terminals form an important part of the casualty power system (fig. 3-21). They are used for connecting the portable cables on opposite sides of bulkheads, so that power may be transmitted through compartments without loss of watertight integrity; also included are permanently installed riser terminals between decks. The vital equipment selected to receive

casualty power will have a terminal box mounted on or near the equipment or panel concerned and connected in parallel with the normal feeder for the equipment.

Sources of supply for the casualty power system are provided at each ship's service and emergency generator switchboard. A casualty power riser terminal is installed on the back of the switchboard or switchgear group and connected to the buses through a 225- or 250-ampere AQB circuit breaker. This circuit breaker is connected between the generator circuit breaker and the generator disconnect links. By opening the disconnect links, you will isolate the generator from the switchboard. Then, it can be used exclusively for casualty power purposes.

### RIGGING CASUALTY POWER

To eliminate the necessity of handling live cables and to reduce the hazards to personnel and equipment, definite procedures must be followed and safety precautions must be observed in rigging casualty power.

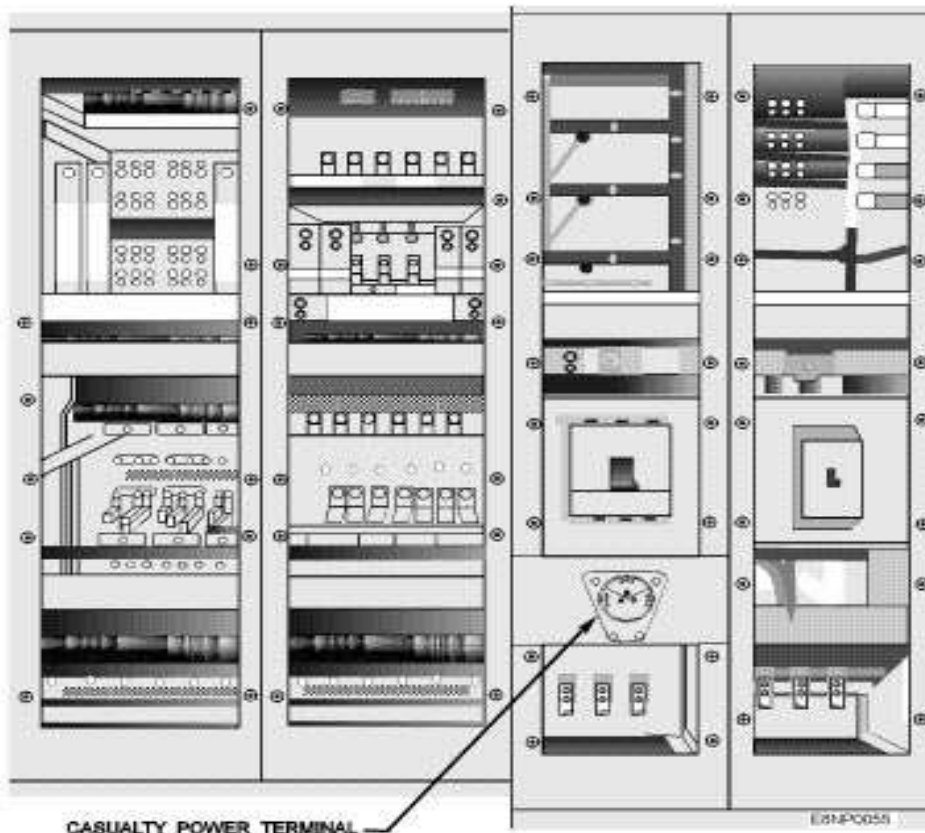


Figure 3-21.-Rear of switchboard showing casualty power terminal.

Only qualified Electrician's Mates should do the actual connecting; however, the portable cables may be laid out by other party personnel. The repair party electrician must wear rubber gloves, rubber boots, and stand on a rubber mat while making connections. Each casualty power riser or bulkhead terminal must be tested with a voltage tester before a connection can be made to the terminal. The duty of the repair party Electrician's Mate is to determine that all sources of power to the equipment concerned are de-energized before rigging casualty power. The portable cable connections for casualty power should always be made by first connecting the load and then working back to the source of power.

On large ships, casualty power runs involve more than one repair party. All repair parties should rig simultaneously, but the rule of "rig from load to source" should always be observed. Each repair party must report its section rigged from riser or bulkhead terminal number to riser or bulkhead terminal number to damage control central.

In all instances of rigging and energizing any part of the casualty power system, only the damage control assistant, with the authority of the chief engineer, has the authority to order the system energized.

In making casualty power connections at a load where there are no circuit breakers or transfer switches to interrupt the incoming feeder cable, the load must be disconnected or cut at the equipment. It is quite possible that the feeder cable may be damaged by the casualty that caused the loss of power. A damaged cable, if energized, would probably trip the casualty power circuit breakers. If not disconnected, this incoming feeder cable may be re-energized, and present a hazard to personnel handling the casualty power cables.

To keep the phase sequence correct in ac systems, exercise care in making all connections. The riser terminals, bulkhead terminals, and portable cable ends are marked to identify the A-, B-, and C-phases. You can make the identification visually by color code. In the dark you can make the identification by feeling the bumps on the riser terminals or feeling the twine wrappings or O-rings installed on the cables.

Ordinarily, portable casualty power cables should be tied to the overhead. High-voltage signs should be attached at each connection and the information passed over the ship's IMC system informing all hands to stand clear of the casualty power cables while energized.

As previously stated, power panels supplying equipment designated for casualty power service will

have a power terminal box mounted on the panel so that power may be fed into the panel. Remember that these panels can also be used as a source of power for the casualty power system should power still be available from the permanent feeder or feeders to the panel. Some judgment should be exercised, however, in the choice of panels to be used for supplying casualty power loads. Heavy loads should be connected to power panels having large incoming feeders for greater assurance that circuit breakers will not trip and that the cable will not become overheated. Current loading of casualty power cables is not considered excessive when you can grasp the cable by hand and it does not cause burning. Portable cable used in ac casualty power systems is Navy LSTHOF 42. Although the normal current carrying capacity of this cable is 93 amperes, its casualty rating is 200 amperes. Under normal conditions this cable will carry 200 amperes for 4 hours without damage to the cable. Cables may be run in parallel to circuits that overload a single cable.

Recommended SAFE procedures to be used in rigging casualty power include the following:

- Upon report of loss of power, damage control central orders the repair party nearest the equipment concerned to investigate.
- The repair party Electrician's Mate of the investigating team immediately tests to determine if all sources of power to the equipment have been lost.
- Upon determining that all power is lost, the Electrician's Mate opens all supply switches to the equipment and reports to damage control central that power is lost to the equipment.
- Upon receiving a report of all power lost, damage control central requests main engine control to designate a source of casualty power for the equipment concerned. The request for a casualty power source may be made to the electrical officer on ships having a combined main engine control and damage control central or where the electrical officer is stationed in damage control central for the control of generators and power distribution.
- Main engine control or the electrical officer, as appropriate, informs damage control central of the casualty power source to be used (giving riser terminal number) and, at the same time, informs the Electrician's Mate on the appropriate switchboard that his or her board has been

designated as a source of casualty power to the riser terminal by number.

- Upon receiving this information, damage control central orders the repair parties concerned to rig casualty power from the equipment to the designated source.
- Repair parties rig casualty power and report each section completed to damage control central.
- After all sections have reported the rigging completed, damage control central requests the main engine control electrical officer to “energize casualty power.”
- Upon receiving the request to energize, main engine control or the electrical officer directs the designated switchboard to “connect and energize casualty power,” and to report compliance.
- The Electrician’s Mate on the designated switchboard rigs the first cable from the source of the system, closes the casualty power circuit breaker, and reports casualty power energized to main engine control, then reports compliance to damage control central.

## **UNRIGGING CASUALTY POWER**

Unrigging casualty power can be hazardous if not handled correctly. The steps to be taken to unrig casualty power lines are as follows:

1. Damage control central requests main engine control to de-energize the casualty power system.
2. Main engine control directs the designated switchboard to de-energize and disconnect casualty power, and to report compliance.
3. The Electrician’s Mate at the switchboard opens the casualty power circuit breaker, unrigs both ends of the first portable cable, and reports “casualty power de-energized,” to main engine control. Main engine control reports compliance to damage control central.
4. Upon receiving the de-energized report, damage control central orders casualty power disconnected at the equipment,
5. The repair party’s Electrician’s Mate disconnects both ends of the last portable cable in the system at the load and reports, when completed to damage control central.

6. Damage control central requests main engine control to energize normal circuits to the equipment and orders repair parties concerned to unrig and restore the remainder of the portable cables.
7. Main engine control directs the designated switchboard to energize all normal circuits to the equipment and to report compliance. Main engine control reports compliance to damage control central. The exercise is not considered completed until damage control central receives the report the equipment is operating on normal power and all portable cables are restored on their proper racks.

Speed is desirable in all casualty power operation; however, safety precautions must never be sacrificed to attain speed. A thorough knowledge of the casualty power system and frequent drills by all personnel involved are necessary for safe and expeditious results.

## **SHORE POWER**

The number and locations of shore power connections vary on different types of ships. Shore power connections are provided at, or near, a suitable weather-deck location to which portable cables from the shore or from ships alongside can be connected to supply power for the ship’s distribution system when the ship’s service generators are not in operation. This connection also can be used to supply power from the ship’s service generators to ships alongside.

Shore-power arrangements and hardware used on both ship and shore installations are so diversified that no specific installation instructions can be outlined in detail. Ashore installation that has one circuit breaker supplying a number of cable sets presents a particular hazard. In this case, you can verify phase rotation and phase orientation only by energizing all shore terminals. You should check phase rotation with only one set of cables installed. The latest designs have a single, 3-phase receptacle for ship and shore-power terminals. These receptacles are keyed in such a manner that phase rotation and orientation cannot be altered provided both the ship and shore use these receptacles, and the cables are not spliced. Phase orientation need not be checked before hookup. Systems that use 3-phase receptacles are normally designed so that interlocks on receptacles automatically trip associated circuit breakers whenever the cover of the receptacle is open, and a shore-power cable plug is not in place. However, you should still

check voltage to these receptacles to ensure they are de-energized before installing the shore cables.

## RIGGING SHORE POWER

The following procedures apply to the shore installation with a separate circuit breaker or disconnect for each set of cables and a single, 3-phase receptacle is not used. You should follow these basic instructions and procedures before and during connecting to shore power.

- Connect and disconnect shore power under the direct supervision of the electrical officer, a qualified leading electrician, and shore-activity personnel.
- Visually inspect shore-power cables for any sign of defects (such as cracks, bulges, and indications of overheating), thoroughly examine spliced cables, in particular, because improperly spliced cables are extremely dangerous. Strip lug-to-lug connection splices of insulation and check the connection for cleanliness, tightness, and good surface contact. Repair all defects and reinsulate all lugs before cables are placed in service. *Check* cables for insulation resistance using a 500-volt Megger (megohmmeter). Insulation resistance readings should meet requirements of *Naval Ships' Technical Manual, "Electric Plant General,"* Chapter 300. Check the resistance between phases and between each phase and ground. For purposes of the test, shore ground should be the enclosure that houses shore-power terminals or receptacles. On ships, ground should be the hull of the ship or any metal extension of the hull. During the physical inspection and Megger tests, check the phase identification of the cables. Pay particular attention to cables that have been spliced to ensure that the phases of the cables are continuous and have not been altered at the splices.
- Tag with high-voltage signs and, if possible, rope off the work area surrounding the ship's shore-power terminal box or receptacle. This box or receptacle is often exposed to elements, and any moisture present can cause a serious problem. With the ship's shore-power breaker tagged in the open position, disconnect all equipment (such as meters and indicator lights) that could be damaged by a Megger test or cause a false reading. Test the terminals in the ship's shore-power terminal box or receptacle with a

voltage tester to ensure they are de-energized. Next, with a 500-volt Megger, test the insulation resistance between terminals and from each terminal to ground.

- Lay out the cable between the supplying shore-power outlet and the ship's shore-power terminal box or receptacle. Ensure that the cable is of sufficient length to allow enough slack for the rise and fall of the tide, but not of such length as to permit the cable to dip into the water or become wedged between the ship and pier. Do not permit cables to rest on sharp or ragged objects, such as gunwales. Avoid sharp bends. Lay cables in wood saddles or wrap them in canvas. Raise splices and connectors from the deck or pier for protection against water contamination. Neatly tuck out excess cable to minimize damage from vehicle and pedestrian movements.
- Connect the shore cables to the ship's shore-power terminals according to phase or polarity markings in the box and on the cables.
- Ensure correct phase orientation (phase relationship) by checking color coding or phase identification markings on cables. Reconfirm correct phase identification by meggering between like phases of cables. Cables that give a zero indication will have the same phase relationship. After meggering, reconnect any disconnected equipment.
- With a voltmeter, check to ensure that the shore-power terminals are de-energized.
- Connect the shore-power cable to the terminals.
- Check for proper phase rotation either by alternately energizing shore-power receptacles, one at a time, and observing the ship phase rotation indicator mounted in the ship's service switchboard or use a portable meter connected to an appropriate bus. After checking phase rotation, de-energize each source shore-power receptacle before energizing the next receptacle for the phase rotation check.
- Energize all source shore-power terminals or receptacles and proceed with the transfer of electrical load to shore power following engineering department operating instructions. Instructions will vary depending upon whether or not the ship is equipped to synchronize with shore power.

After cables are carrying the load, inspect all connections to locate any possible overheating resulting from poor connections or reduced copper in the circuit. Inspect cable ends at the point of connection for heavy strain or overheating.

Shore-power cables are rated at 400 amperes. Check switchboard meters to ensure that the total load on shore-power cables does not exceed the combined rating of shore-power cables. Total shore-power load in amperes should be no more than 400 times the number of shore-power, 3-phase cables connected per phase.

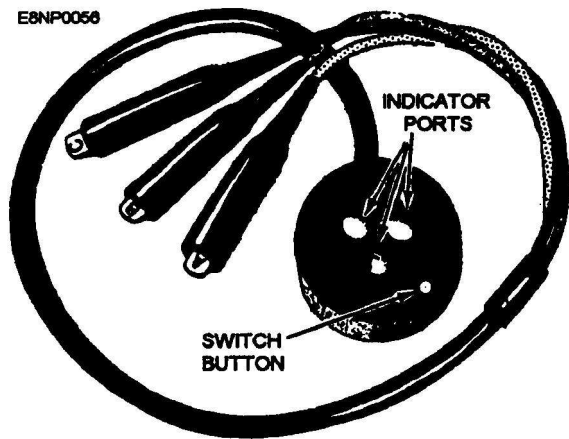
### PHASE-SEQUENCE INDICATOR

A phase-sequence indicator is used when you are connecting shore-power to your ship to ensure proper phase relationship between ship power and shore power.

An approved type of phase-sequence indicator (fig. 3-22) has a miniature, 3-phase induction motor and three leads with insulated clips attached to the ends. Each lead is labeled A, B, and C. The miniature motor can be started by a momentary contact switch. This switch is mounted in the insulated case with a switch button protruding out the front of the case to close the switch. When the motor starts turning, you can tell its direction of rotation through the three ports in the front of the case. Clockwise rotation would indicate correct phase sequence. You can stop the motor by releasing the momentary contact switch button.

### UNRIGGING SHORE POWER

When disconnecting shore power, observe the same safety precautions outlined in the connecting sequence except for those regarding meggering cables and checking phase orientation and phase rotation. Again,



**Figure 3-22.-Phase-sequence indicator.**

tag shore-power breakers and disconnect following safety procedures. Determine that the shore-power busing and cables are de-energized by using a voltage tester that has just been checked with a known energized power source.

**NOTE: Moving energized shore-power cables is prohibited.**

### SUMMARY

In this chapter you have been introduced to the ac power electrical distributions system. We have studied the electrical distribution system, bus transfer switches, ship's service switchboards, ac generators, transformers, 400-Hz power distribution, casualty power, and shore power. Possessing a good understanding of the ac power distribution within your assigned spaces, will greatly enhance your ability to restore ac power to your equipment in the event of its loss or re-configure to alternate, casualty, or shore power.



## CHAPTER 4

# SHIP'S INPUT SYSTEMS

A ship's input system is defined as a system that provides an essential input to an equipment or another system and is maintained by the Electronics Technicians (ETs). These input systems receive data from equipment generally maintained by another department, such as engineering. The data is distributed throughout the ship to other users as well as engineering. Many of these systems are on board Navy ships.

In this chapter, we will discuss the basic gyrocompass system and the basic underwater log system. Because these two systems are the sole responsibility of the engineering department and unauthorized personnel are not permitted access to them, no attempt will be made to teach the maintenance of these systems. Only a brief description of the overall system will be provided. This knowledge will assist you with a better understanding of the ship's input to your equipments and systems especially during troubleshooting.

### GYROCOMPASS SYSTEMS

The gyrocompass provides a means of determining ownship's heading, roll, and pitch of the ship. Gyrocompass systems include the Mk 19, Mk 23, Mk 27, and AN/WSN-2. The gyrocompass system transmits information to weapons control, sonar, radar, degaussing, depth control, dead reckoning and other equipment or systems as required. Components of the gyrocompass system include: gyrocompass control Cabinets, power supply, indicators for ship's heading, roll, and pitch (analog and digital), synchro signal amplifiers, and synchro signal converters. Normally the Interior Communications Technician (IC) and Electrician's Mate (EM) will maintain this equipment.

Gyrocompasses are identified by the mark (Mk) modification (Mod) system. The Mk number designates a major development of a compass. The Mod number indicates a change to the major development. Two new gyrocompass systems are currently being installed on Navy ships. These are the stabilized Gyrocompass Set AN/WSN-2 and the Inertial Navigation Set AN/WSN-5. We will briefly discuss both in this chapter.

### MK 19 GYROCOMPASS

The Mk 19 gyrocompass seeks and continuously indicates the degree of the ship's roll, pitch, and heading. The Mk 19 gyrocompass furnishes precise synchro roll, pitch, and heading data for use in navigation equipments. It also is used in stabilizing surveillance, sub-surface search (sonar), surface search, air search, navigation, and fire control radar systems. The Mk 19 gyrocompass consists of four major components: master compass, control cabinet, failure annunciator, and power supply as shown in figure 4-1. The Mk 19 gyrocompass system is installed aboard warships (submarines, DD types, and larger), amphibious warships (LSDs and larger), auxiliary ships (longer than 91 meters (300 feet), patrol ships (FF types and larger), and mine warfare ships.

### Output Signals

These Mk 19 gyrocompass provides the following output signals: heading (1X, 36X synchro), roll and pitch (2X, 36X synchro). The heading data is provided on two different buses: normal and critical. To prevent overload of the static power supply when operating on battery power, the normal bus is disconnected and only those indicators on the critical bus remain operational.

### Heading Indicators

Heading indicators display ownship's heading information received from the ship's gyrocompass system. The indicators may be either synchro-servo or digital indicators. The indicator may be single (1X) or combined single and thirty-six (1X, 36X) speeds. Thirty-six speed indicators are used for precise readings. Digital indicators provide a three-digit, solid-state, readout of ship's heading with a range of 000 to 359 degrees in one-degree increments.

Single and thirty-six (1X, 36X) speed indicators are provided in areas such as:

- AFT Steering—each trickwheel and emergency steering
- Pilot House—ship control console, OOD steering, and bridge wings (pelorus)

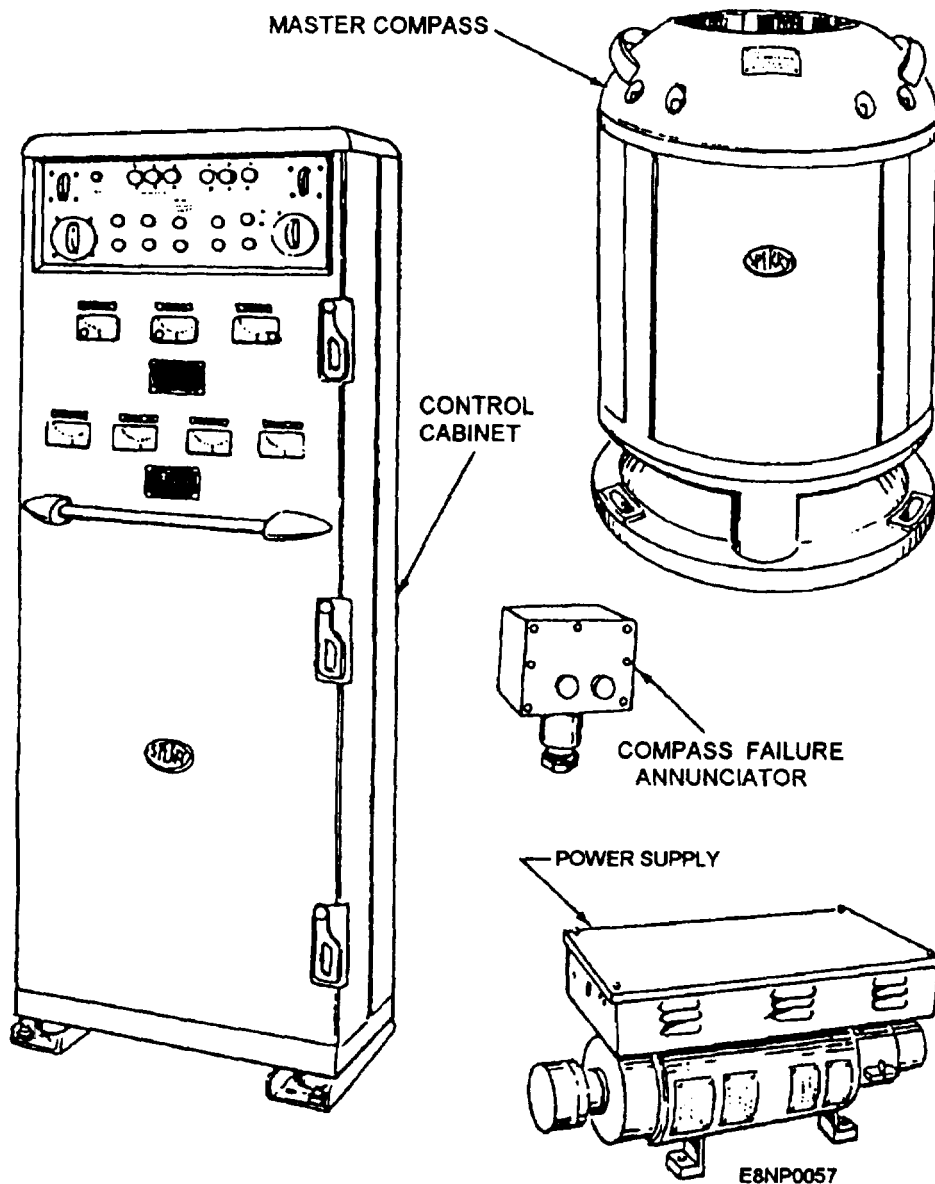


Figure 4-1.—Mk 19 Mod 3A gyrocompass equipment.

- Gyro mom
- Ship control station-outboard and inboard positions

Single (1X) speed indicators are provided in areas such as:

- Pilot house-chart table, CO's chair
- CIC—command table, surface ops, and sub-surface ops
- Sonar control
- Air ops
- Tactical air control

### Mk 23 GYROCOMPASS SYSTEM

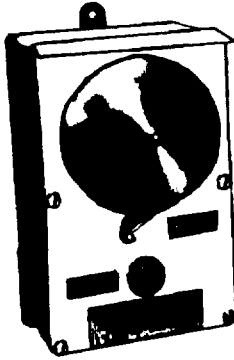
The Mk 23 gyrocompass system seeks and continuously indicates bearing or true north. The Mk 23 gyrocompass is capable of withstanding severe operating conditions in small boats, amphibious vehicles, surface vessels, and submarines. The Mk 23 gyrocompass consists of six major units the master unit, the control cabinet, alarm bell, compass failure annunciator, alarm control, and speed unit (depicted in figure 4-2).

### Output Signals

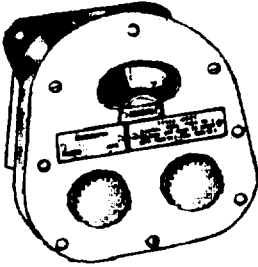
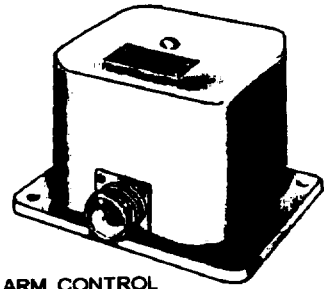
The Mk 23 gyrocompass provides 1X and 36X synchro data and heading to external equipments and systems.

ETNP0058

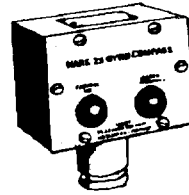
ALARM BELL



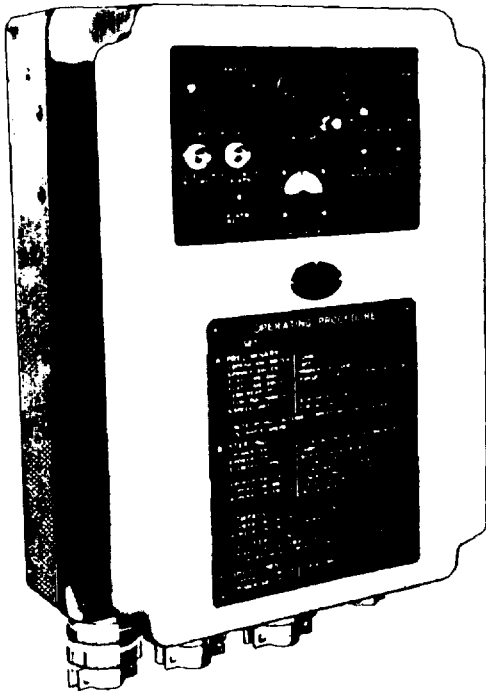
ALARM CONTROL



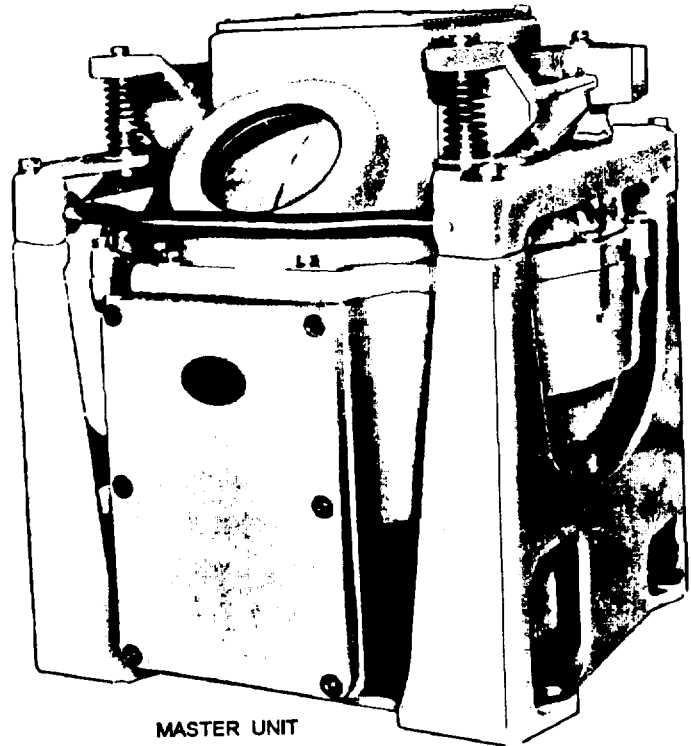
SPEED UNIT



COMPASS FAILURE  
ANNUNCIATOR



CONTROL CABINET



MASTER UNIT

Figure 4-2.—Mk 23 Mod 0 gyrocompass equipment.

## Mk 27 GYROCOMPASS SYSTEM

The Mk 27 gyrocompass is primarily a direct reading compass. This compass seeks and continuously indicates the bearing or true north. This gyrocompass consists of three major components: master unit, control cabinet, and power converter, as depicted in figure 4-3. Optional equipment includes a switching unit and a speed compensator. The Mk 27 gyrocompass can be configured to provide heading information to a remote area with a step transmitter, 1X or 36X synchro data transmitter, or a combination of these units.

### AN/WSN-2 STABILIZED GYROCOMPASS SET

The AN/WSN-2 stabilized gyrocompass, shown in figure 4-4, seeks and continuously indicates the

meridian and zenith. The AN/WSN-2 provides precise output signals for ship's heading, roll, and pitch. The set uses an accelerometer-controlled, three-axis, gyro-stabilized platform to produce vital heading synchro data and reference, nonvital heading synchro data, and both roll and pitch angle synchro data. The AN/WSN-2 stabilized gyrocompass consists of five major components: inertial measuring unit, control indicator, control power supply, amplifier synchro signal, and battery set.

The AN/WSN-2 provides the following output signals: heading vital and nonvital (1X, 36X 400HZ synchro), roll and pitch (2X, 36X400 Hz synchro), and remote alarm.

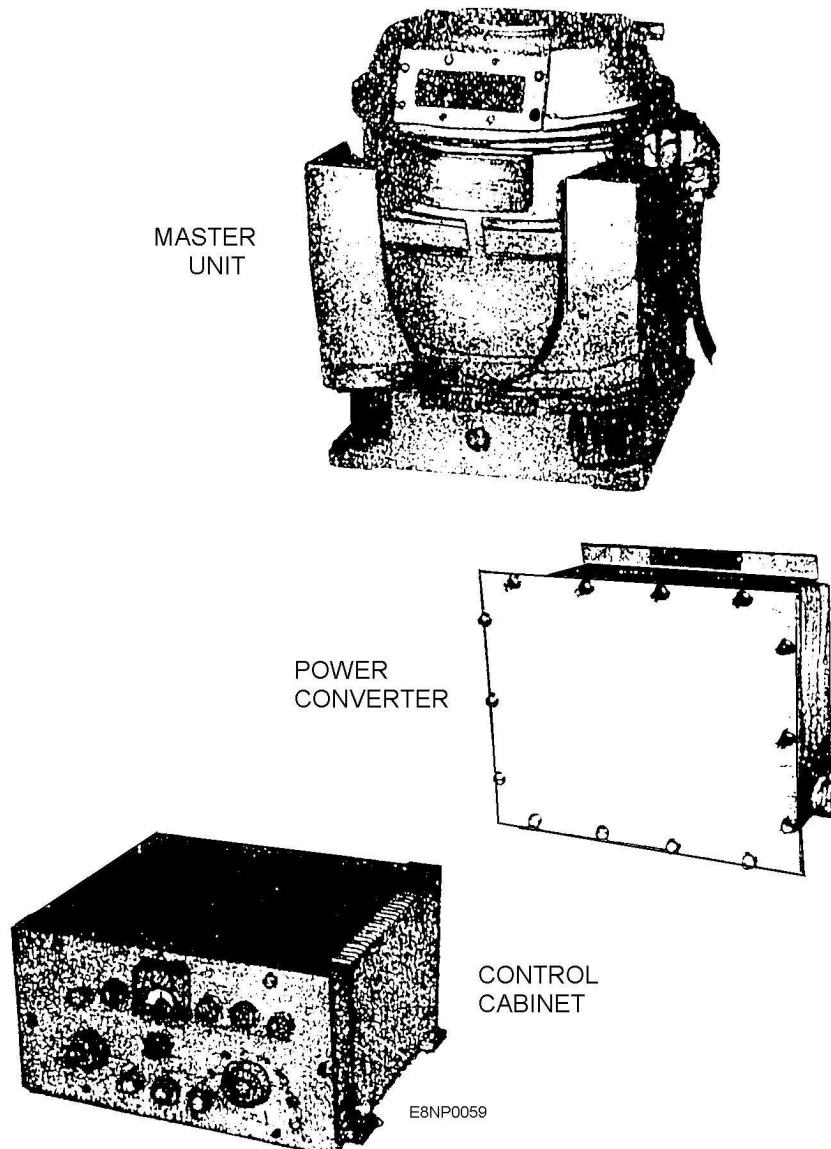


Figure 4-3.—Mk 27 Mod 0 gyrocompass equipment.

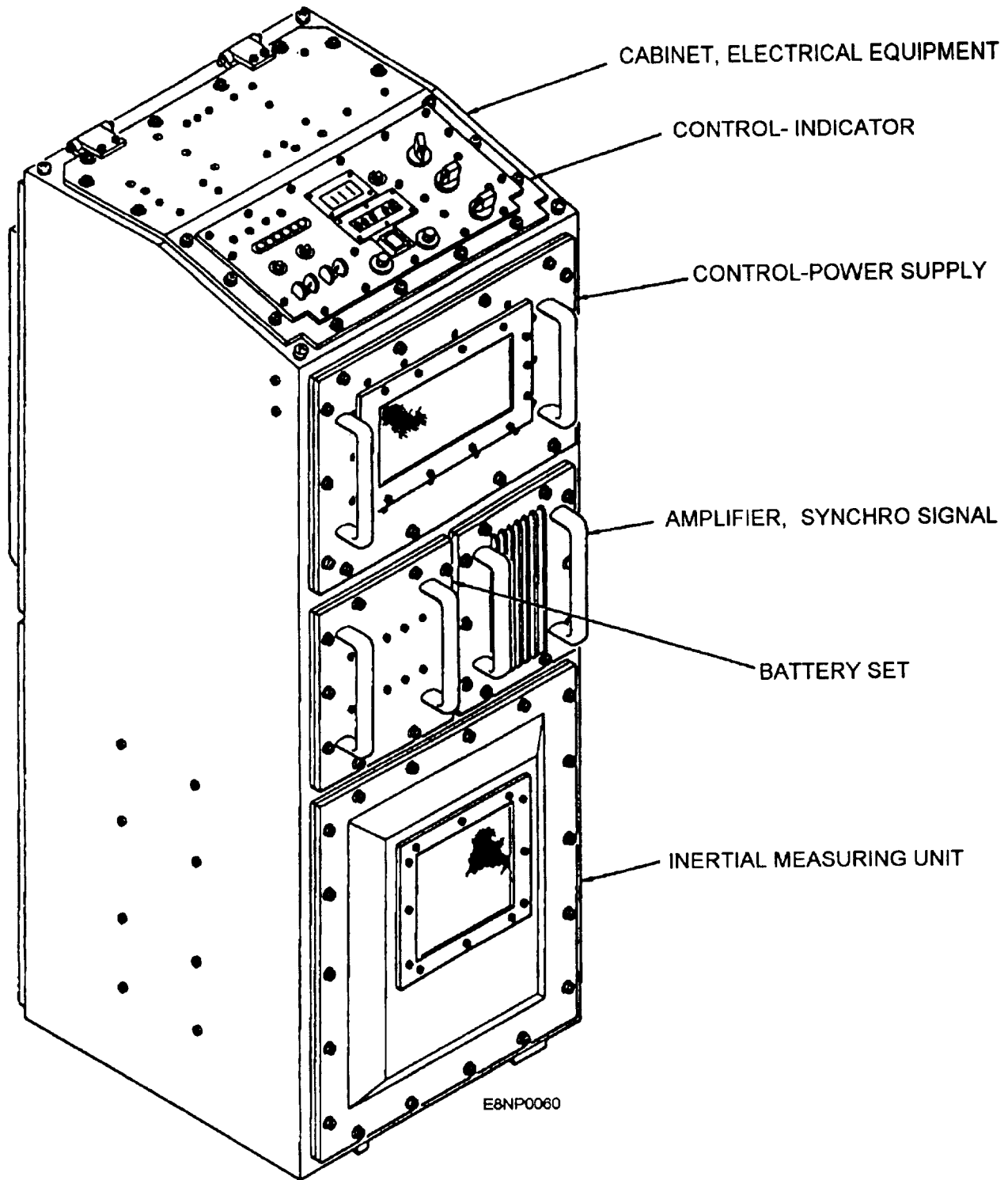


Figure 4-4.-Stabilized Gyrocompass Set AN/WSN-2.

### SYNCHRO SIGNAL AMPLIFIERS

Synchro signal amplifiers are installed where it is necessary to increase synchro load capacity, isolate synchro loads, or convert to a different synchro speed or output frequency. Generally, each radar system will

have its own synchro signal amplifier, and the Preventive Maintenance System (PMS) will usually assign responsibility for the amplifier to the work center that has responsibility for the system it directly feeds (i.e., SPS-55, SPS-49 will each have its own synchro signal amplifier.)

Figure 4-5 is an illustration of a synchro signal amplifier. Indicator lights for input and output excitation, servo follow-up, fuses, an alarm switch, and a dimmer switch are mounted on the front of the amplifier. The indicator lights, when lighted, indicate that power is available and the servo system is operating. The 2-amp slow blow fuses are contained in indicators that light when a fuse blows. The alarm switch silences the audible alarm during an alarm condition. An audible alarm will sound for a loss of input or output excitation and for a servo follow-up error. The dimmer switch adjusts the brightness of the indicator lights. A heading dial is also mounted on the back of the panel with a window for viewing ship's heading.

## AN/WSN-5 INERTIAL NAVIGATION SYSTEM

The AN/WSN-5 inertial navigation sets are installed on larger, newer ships—cruisers and earners. They continuously indicate the bearing and the zenith, thus serving as a reference for measuring the ship's roll, pitch, heading, and velocity north and east. The sets are a motion-sensing system that provides digital data (i.e., geographical position; horizontal and vertical velocity; attitude angle, and rate of heading, roll and pitch), and analog dual-speed synchro signals (i.e., heading, roll, pitch, velocity north and velocity east) for use by ownship equipment.

### SYNCHRO SIGNAL CONVERTER

Synchro signal converters are used to increase the capacity of a synchro signal transmitter system, converting 60-HZ to 400-HZ synchro transmission, 400-Hz to 60-Hz synchro transmission, and converting relative bearing signals to true bearing signals. Additionally, they can convert to a different synchro speed or frequency, and isolate reflected oscillations from the input synchro bus. Synchro signal amplifiers can be paralleled to increase load capacity.

Two ANWSN-5 sets are usually installed, one in the forward IC gyro room and one in the aft IC gyro room. Ship's position can be updated automatically by NAVSAT/NAVSTAR or manually from the keyboard. The operational program, which resides in the control power supply, performs the functions necessary to gather navigation and status data, compute position, velocity and attitude, and route the data. It processes this data into a suitable format, and transmits the formatted data to various combat systems users. Also the AN/WSN-5 operational program gathers AN/WRN-5A (V)2 reference data as an additional input for updating the AN/WRN-5 navigation data. The

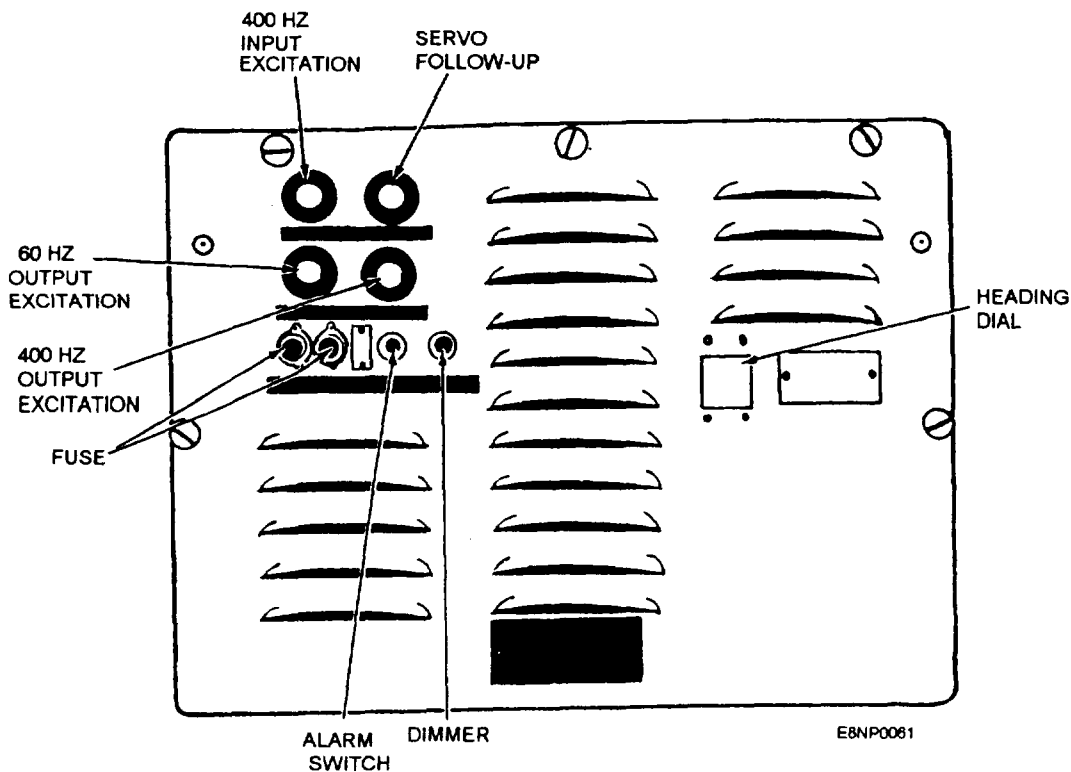


Figure 4-5.-Synchro signal amplifier,

AN/WSN-5 consists of five major assemblies in an electrical cabinet:

- Control-indicator
- Control-power supply
- Battery set
- Synchro signal amplifier
- Inertial measuring unit

The AN/WSN-5 supplies the following output signals: heading (1X, 36X 400Hz), roll and pitch (2X, 36X 400 Hz), velocity north (1X, 10X 400Hz), and velocity east (1X, 10X 400HZ).

### UNDERWATER LOG SYSTEM

The underwater log system measures and indicates the speed of the ship in knots and the distance traveled through the water in nautical miles. Two types of underwater log systems are currently available, electro-magnetic and Doppler. We will discuss the

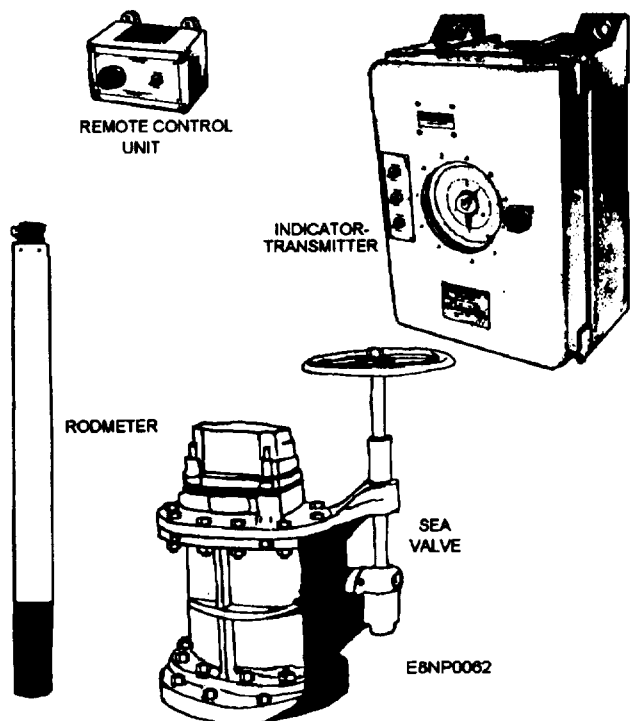


Figure 4-6.—Major components of the underwater log system.

electro-magnetic type in this chapter. The major components of this system, as depicted in figure 4-6, are the sea valve, rodmeter, indicator-transmitter, and remote control unit.

### SEA VALVE

Mounted in the hull of the ship, the sea valve (fig. 4-7), and packing assembly provides a watertight support for the rodmeter. It also functions to seal the hull of the ship when the rodmeter is removed. The sea valve has no function relating to the production, transmission, flow, or conversion of data in the underwater log system.

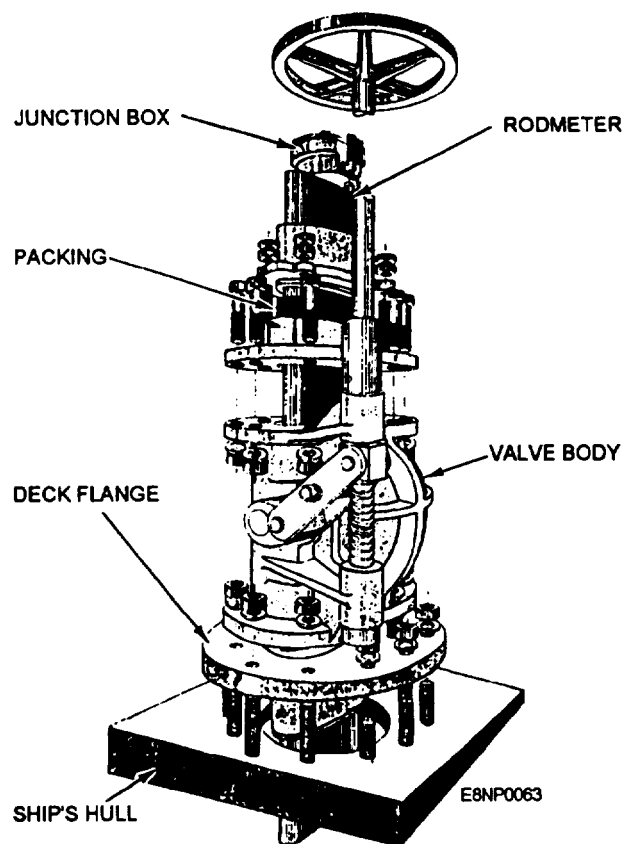
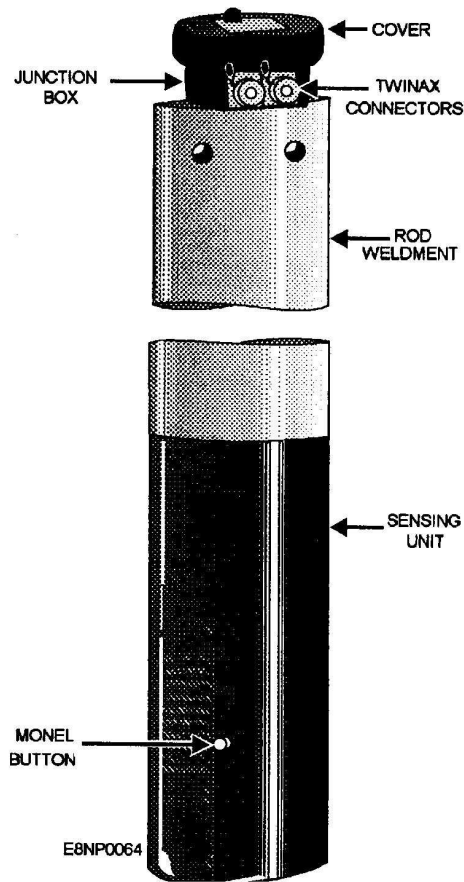
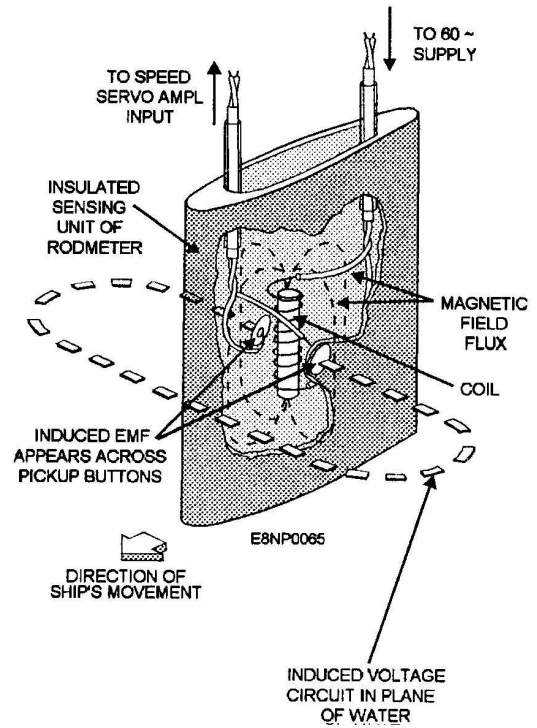


Figure 4-7.—Exploded view of these valve.



**Figure 4-8.-Rodmeter.**



**Figure 4-9.-Rodmeter sensing unit.**

The magnitude of the induced voltage is proportional to the speed of the water flowing through the magnetic fields. Even when the ship is stationary, a current flowing around the rodmeter will cause a voltage to be induced.

**RODMETER**

The rodmeter (fig. 4-8), or sword as it is commonly called, provides an ac signal that is proportional to the ship's speed. The sensing unit (fig. 4-9) of the rodmeter is contained in a boot at its lower end. The rodmeter operates on the principle of electromagnetic induction, that is, when a conductor is made to move in a magnetic field so that it cuts through the lines of flux, an electromotive force (emf) is induced in the conductor. In the case of the rodmeter, a 60-HZ current is supplied to a coil in the boot of the rodmeter. As the current flows through the coil, a magnetic field is produced that surrounds the rodmeter. The water, the conductor in this instance, flows around the rodmeter and cuts through the magnetic field. The induced voltage is felt at the contacts, or buttons, on either side of the rodmeter.

**INDICATOR-TRANSMITTER**

The indicator-transmitter displays the ship's speed on a dial and the distance traveled on a counter and transmits the speed and distance information to various equipment and remote indicators throughout the ship.

**REMOTE CONTROL UNIT**

The remote control unit, or dummy log as it is commonly referred to, is used in place of the rodmeter when the ship is operating in shallow water, where lowering the rodmeter is impractical. The unit is normally located in the main propulsion control station. It has a spring-loaded, center-off, increase-decrease



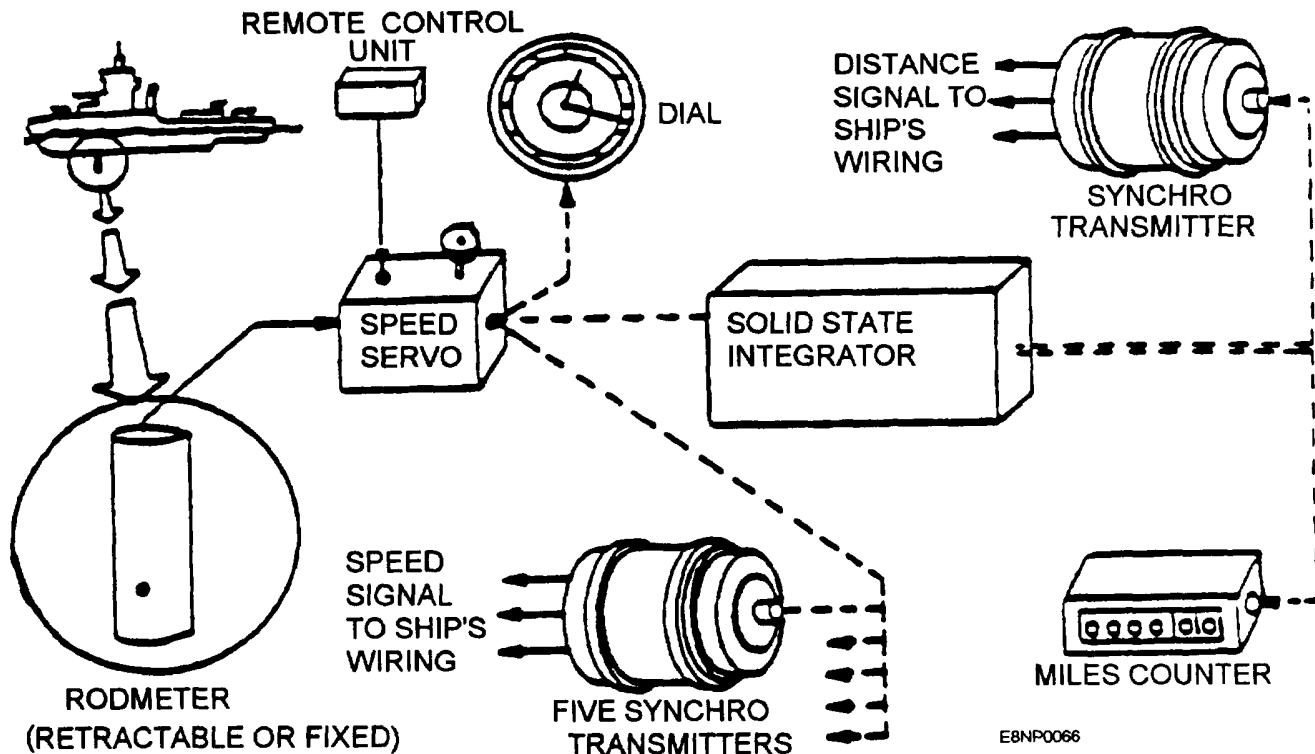


Figure 4-10.-Underwater log system.

switch and is operated by the throttleman. The shaft rpm is used to determine approximate ship's speed.

### OUTPUT SIGNALS

The underwater log system (fig. 4-10) provides 60-Hz synchro signals scaled at 40 and 100 knots/revolution and 400-Hz signals scaled at 10, 40, and 100 knots/revolution. A resettable distance counter is provided on the front of the indicator-transmitter. Distance output is a 60-Hz synchro signal scaled at 360 revolutions per nautical mile.

### SUMMARY

In this chapter, we introduced some of the most common gyrocompass systems—Mk 19, Mk 23, Mk 27, and AN/WSN-2. Additionally, we talked about the AN/WSN-5 inertial navigation system, electromagnetic underwater log system, and the data they Supply.

If a failure were to occur in one of these systems and introduce error to your equipment, you are now better able to isolate the faulty equipment and restore the overall system operability.



## CHAPTER 5

# INFORMATION TRANSFER SYSTEMS

Shipboard tactical data systems need to be interconnected with each other and with equipment in other shipboard subsystems. This interconnection is accomplished through switchboards. Presently the Data System Technicians (DS) are responsible for and maintain two major types of switchboards: digital switchboards and analog switchboards.

The Electronics Technician (ET) rating is responsible for and maintains many systems that supply information to these switchboards. For this reason, it's important that the ET become familiar with and have a basic understanding of what these switchboards are and how they work.

### SWITCHBOARDS

Digital switchboards primarily interconnect digital devices. These types of interfaces include computer-to-computer interfaces and computer-to-peripheral devices and other serial or parallel digital interfaces.

Analog switchboards provide the interconnection for analog devices and signals including control and status signals, synchro signals, and linear signals. In addition, analog switchboards provide supply and return voltages and reference voltages for analog signal exchanges. Most current shipboard combat direction systems use a combination of analog and digital switchboards to completely interface one system with another as well with other shipboard subsystems.

### DIGITAL SWITCHBOARDS

The two basic types of shipboard digital switchboards are manual switchboards and remotely-controlled switchboards.

#### Manual Switchboards

Manual switchboards (fig. 5-1) are made up of variable configurations of three-position or five-position switches. Each individual switch must be

manually positioned for the interconnection required by the current system configuration. At least two manual switches, one for input and one for output, are required for each I/O device or computer channel to allow for the complete range of system configuration requirements (fig. 5-2). Manual switchboards are for the most part being replaced by remotely-controlled switchboards.

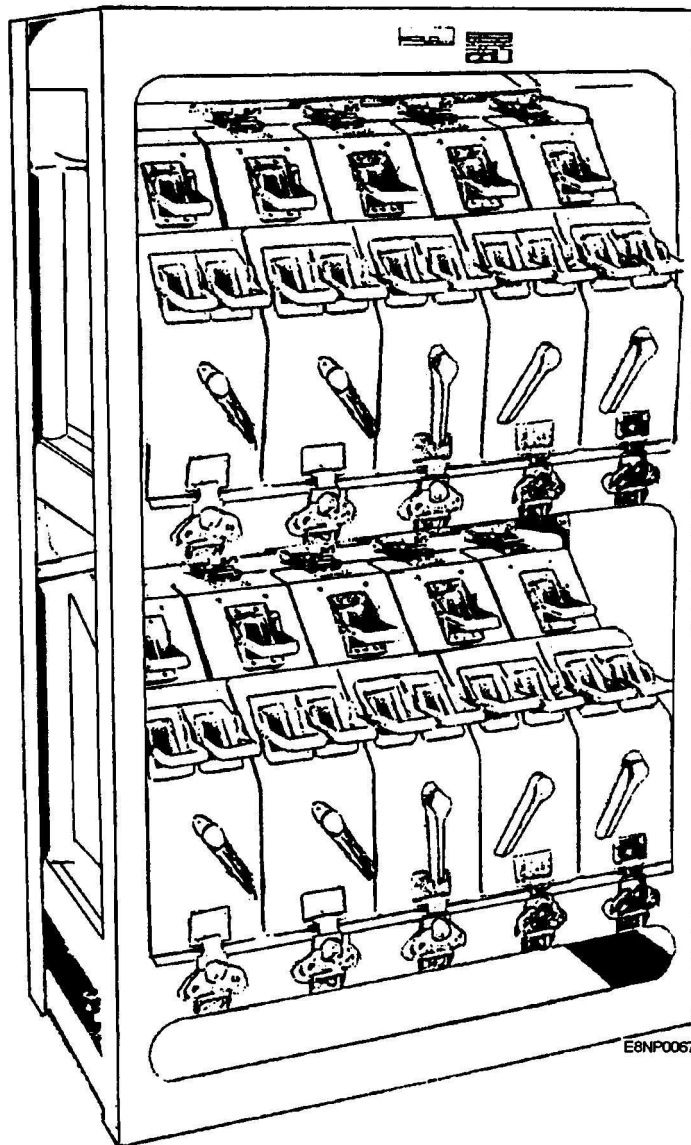
#### Remotely-Controlled Switchboards

Remotely-controlled switchboards (fig. 5-3) allow for configuration changes to be controlled from one or two remote computer switching control panels (CSCPs) (fig. 5-4). The actual switch configuration and data routing take place in the CDS digital fire control switchboard (DFCS). This greatly reduces the time required for configuration changes in the event of equipment casualties.

As examples of DFCS and CSCP, we are using the Mk 70 Mod ( ) DFCS and the Mk 328 Mod ( ) CSCP. The Mod numbers of the DFCS and CSCP will vary with the ship class on which they are installed. For training purposes we refer to the Mk 70 as the DFCS and the Mk 328 as the CSCP.

### DIGITAL FIRE CONTROL SWITCHBOARD (DFCS)

The digital fire control switchboard (DFCS) (fig. 5-3) provides data routing, power monitoring, action cutout (ACO) switching, and digital switching. The switchboard uses remotely-operated switches and other assemblies to perform these functions. The switches route digital signals through the switchboard during normal operation. The digital signals consist of groups of parallel bits that form digital words. The digital words are transmitted between computers, associated peripheral equipment, and digital equipment in other



E8NP0067

Figure 5-1.—Manual switchboard.

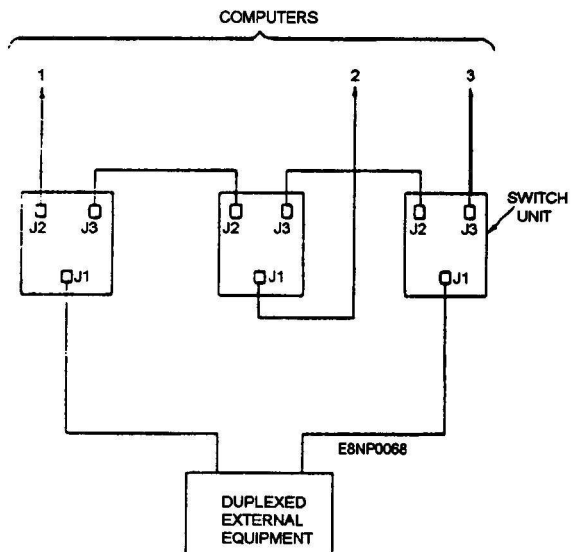


Figure 5-2.—Sample manual switching configuration.

subsystems as shown in figure 5-5. The switches also can be used to interrupt or redirect signal flow manually during maintenance operations.

Control and status signals are normally used to initiate the switching action and monitor the status of the switch positions. The CSCP generates control signals to select the desired switch configuration on the switchboard. Status signals from the switchboard light indicators on the CSCP to display the current switching configuration. In a casualty situation, manual positioning of switches can be performed.

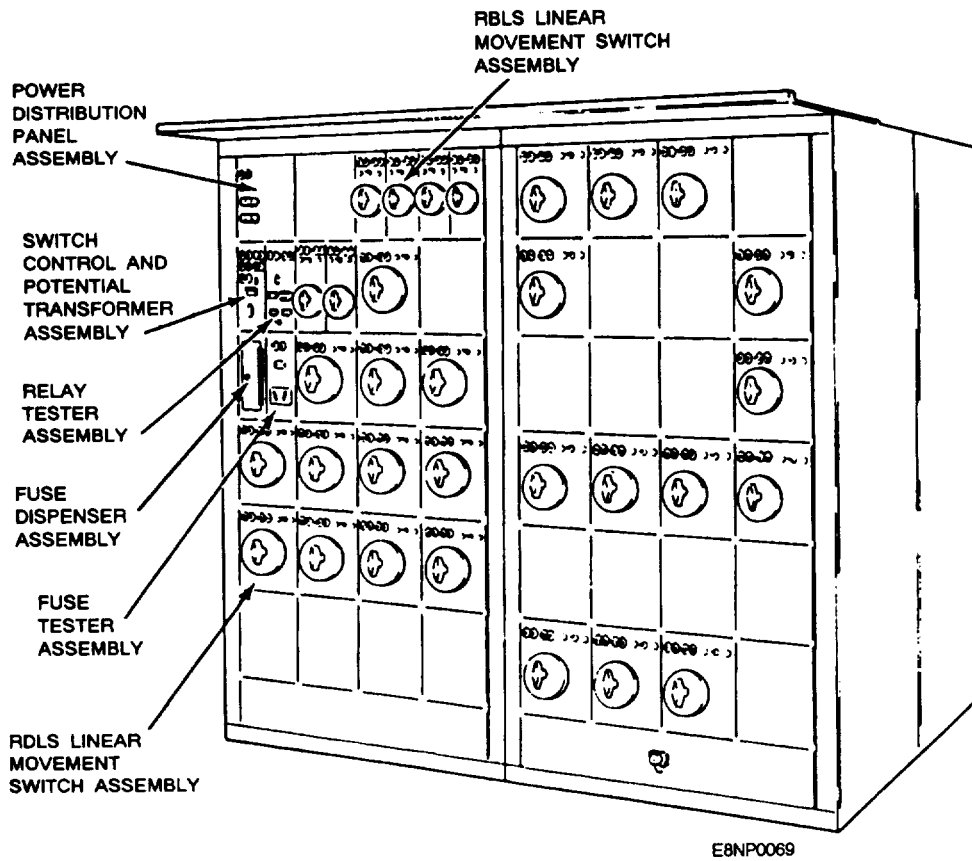


Figure 5-3.—Digital fire control switchboard (DFCS).

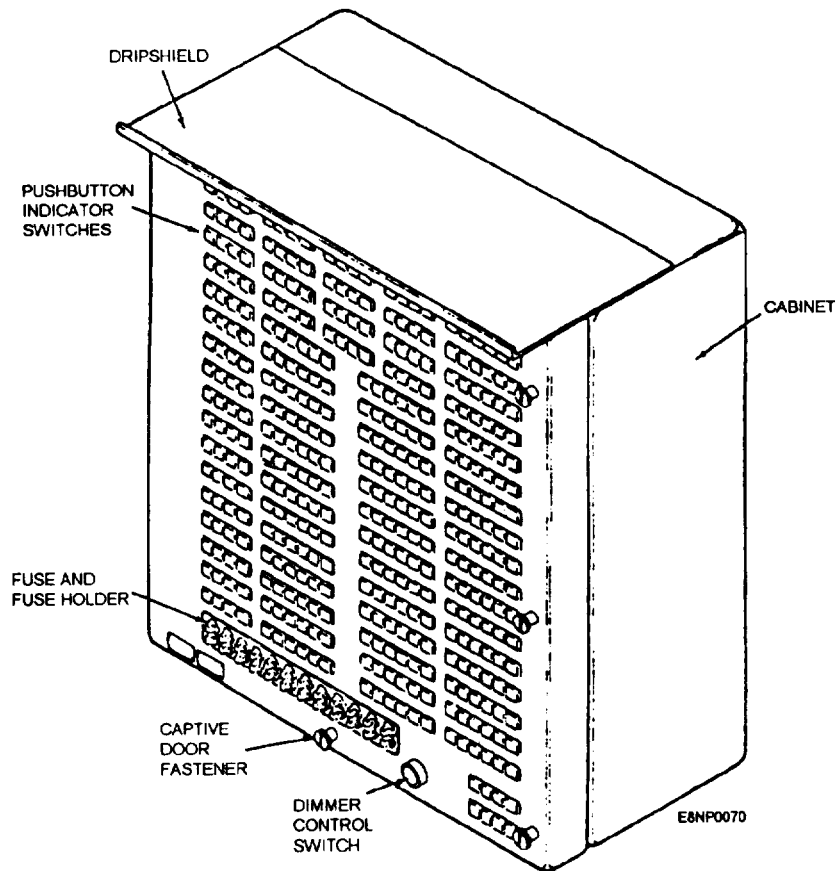
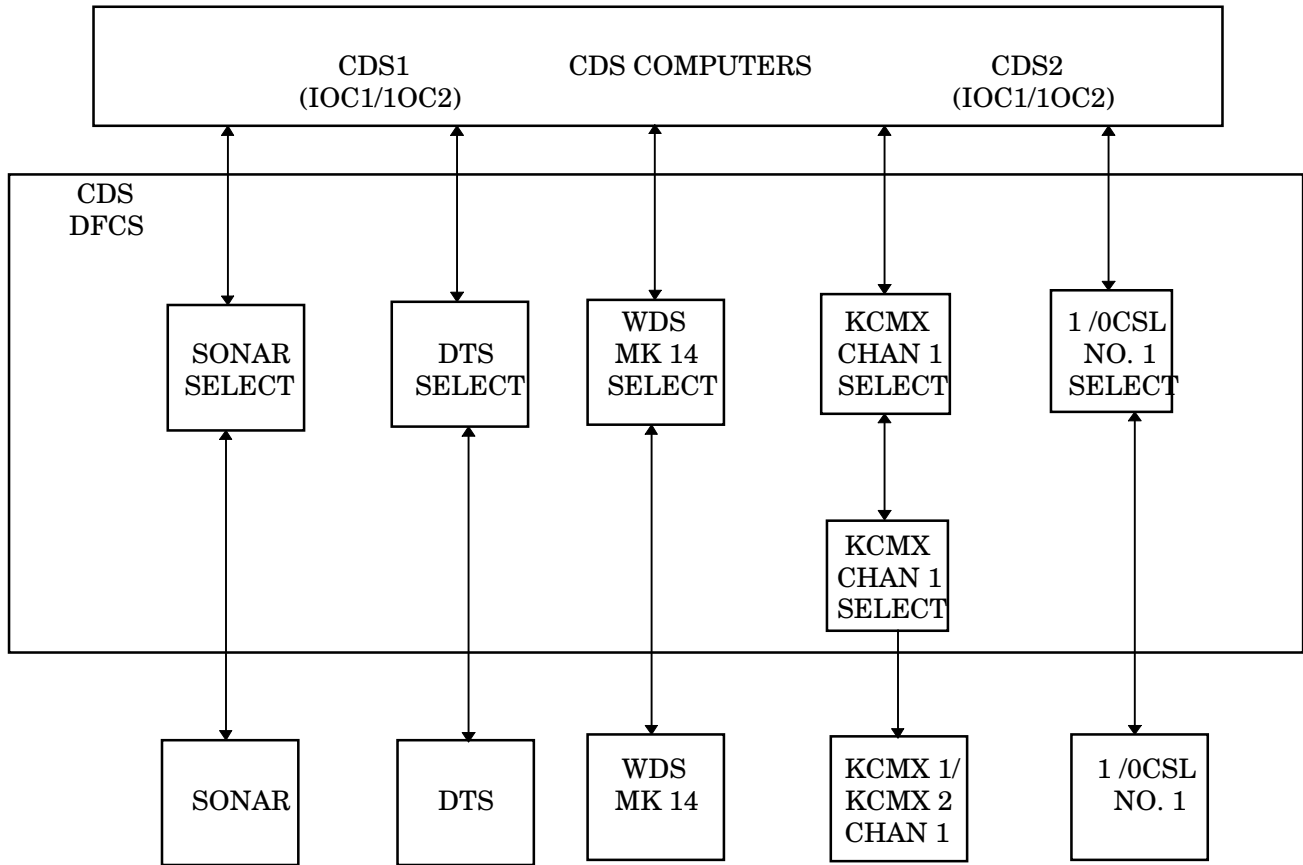


Figure 5-4.—Computer switching and control panel (CSCP).



E8NP0071

**Figure 5-5.—Equipment interconnection through the CDS DFCS.**

The DFCS is comprised of two or more switchboard sections (fig. 5-3) covered with variable configurations of switch panels. Each panel type performs a specific function. The 24 panels per section are normally arranged in groups according to the functions performed by the panels. The front panel of each switchboard section is hinged on the left side to allow access to the interior of the switchboard. The interior of the switchboard (fig. 5-6) contains a system of modules and terminal board connectors that allow ship's wiring to be interconnected to the appropriate switch panels.

The switchboard panel locations are numbered for identification purposes starting at the upper-left corner of the switchboard. The numbering continues from top to bottom, left to right. Each panel is marked with a designation plate mounted on the upper-left corner of each panel assembly or with a blank plate.

### **Power Distribution Panel**

The power distribution panel (fig. 5-7) provides a visual indication of power supplied to the switchboard. Six indicators are mounted on the front of the panel and lighted when the appropriate power has been applied to the panel and is distributed to the remainder of the switchboard.

### **Linear Movement Switch Assemblies**

The majority of panel assemblies are linear movement switch assemblies. These assemblies route a specific number of circuits. The linear movement switch assemblies are normally positioned by control signals from the CSCP, but they may be manually positioned.

Two types of linear movement switch assemblies are the R3DLSO-1B/R5DLSO-1B

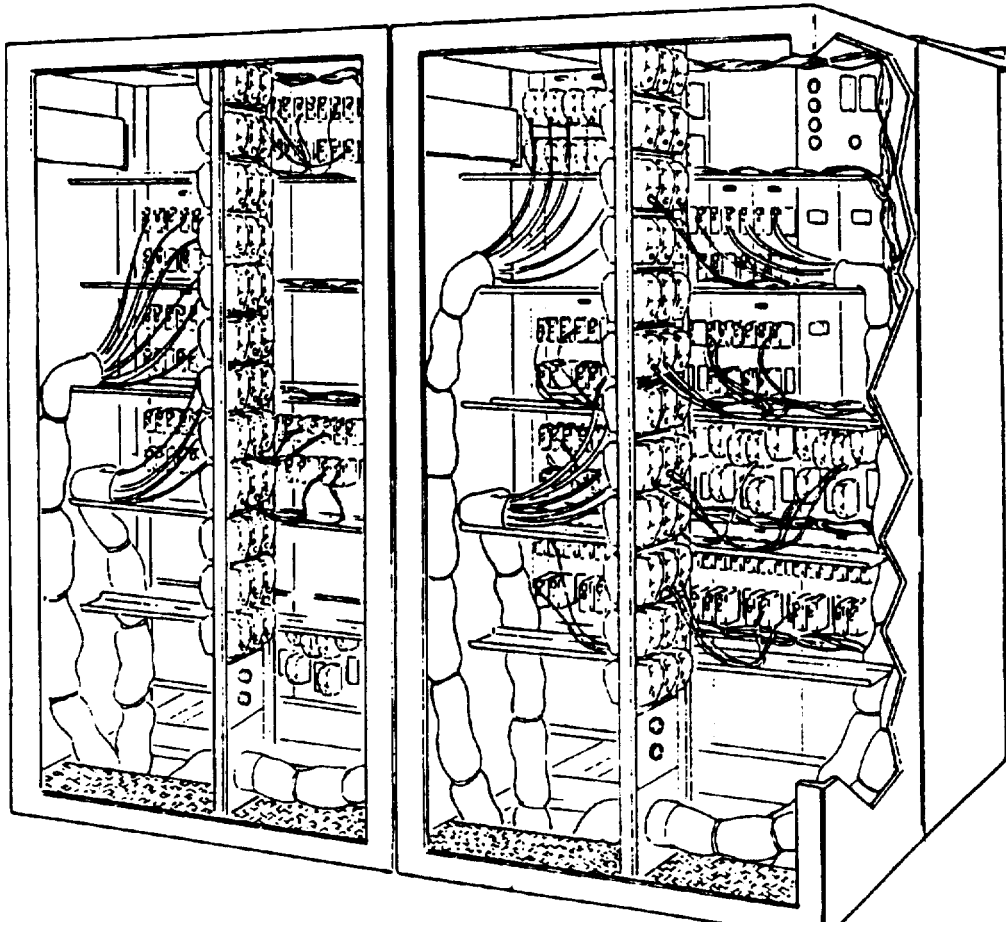


Figure 5-6.-DFCS interior.

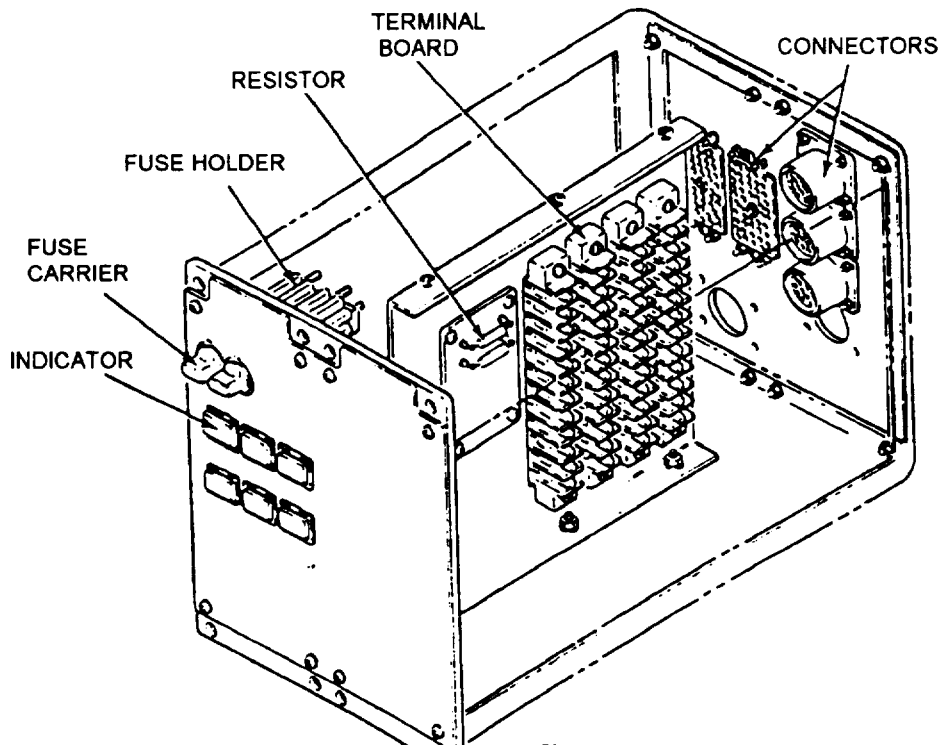


Figure 5-7.—Power distribution panel assembly.

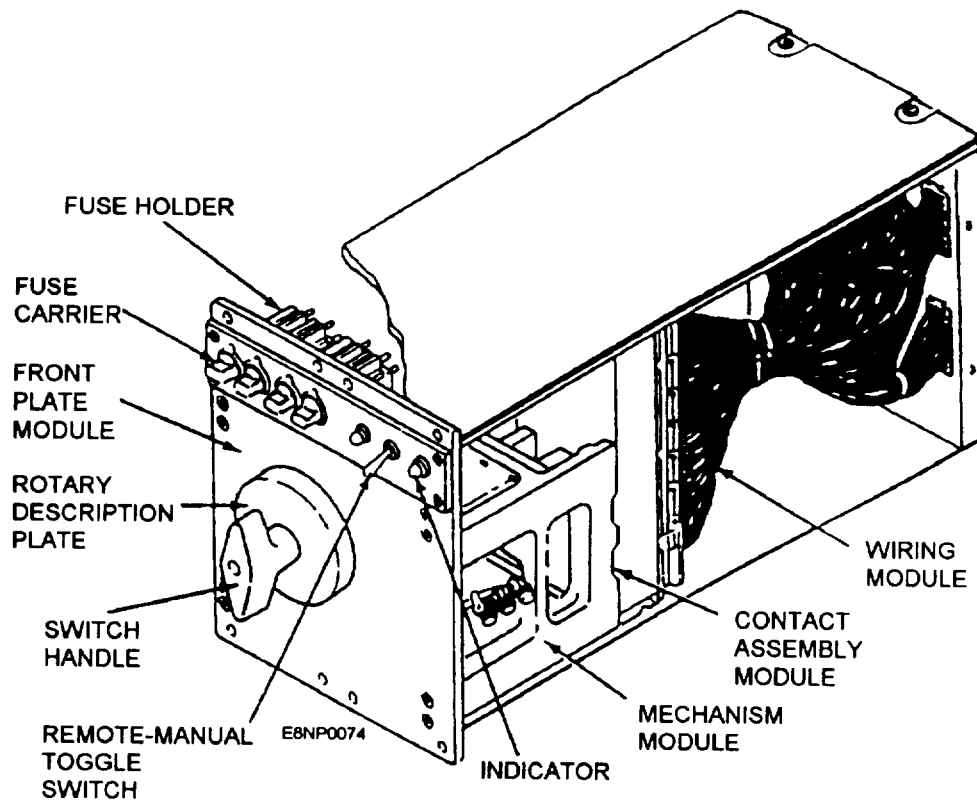


Figure 5-8.-R3DLSO-1B/R5DLSO-1B linear movement switch assembly.

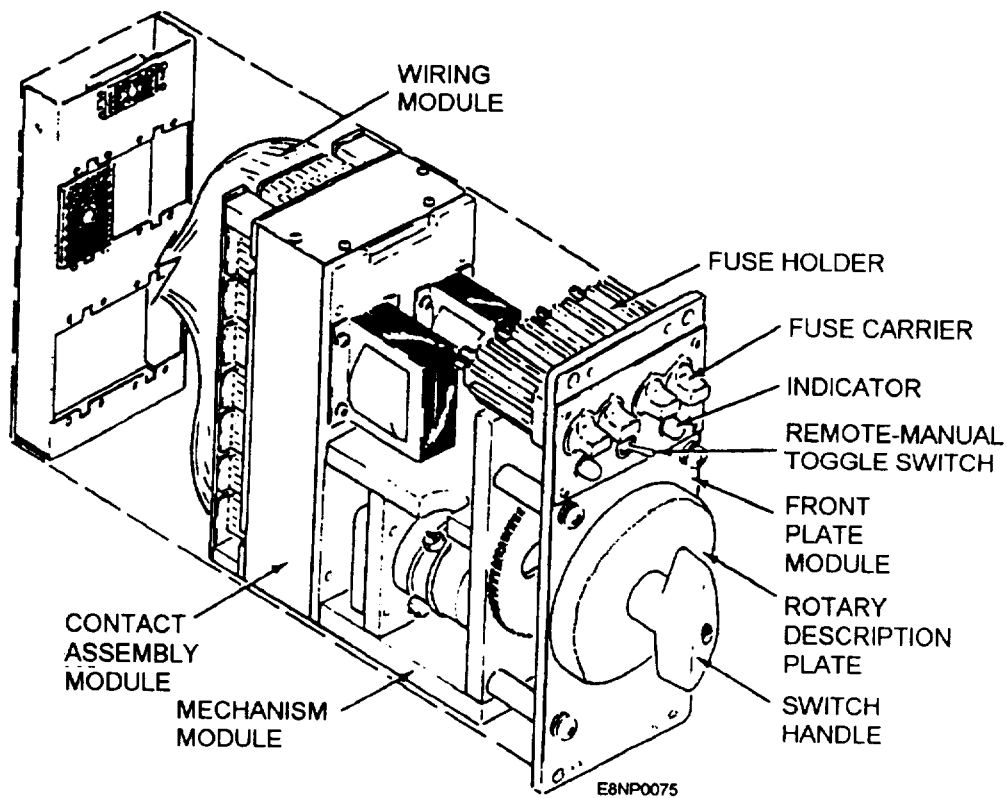


Figure 5-9.—R3BLSO-1C/R5BLSO-1C linear movement switch assembly.



(fig. 5-8) and the R3BLSO-1C/R5BLSO-1C (fig. 5-9) assembly. The assemblies differ from each other in the front panel organization and in the wiring module capabilities. The panels provide different arrangements of 20-pin, 38-pin, 117-pin, and 120-pin connectors.

Both types of linear switches have similar mechanism and contact assembly modules. The mechanism assembly module contains the drive motor, the control circuit module, and the control transformers for remote operation of the switch. The contact assembly module consists of a stationary control plate and a moveable plate to perform the switching functions.

The linear switches perform either three-position (R3) or five-position (R5) switching functions. The

three-position switches are used for NORMAL/ALTERNATE Configuration switching with an OFF position for circuit isolation. The five-position switches have an OFF position with the four other switch positions being used for circuit configuration or reconfiguratin. For an example, see figure 5-10. One channel of a duplexed magnetic tape unit can be switched between four separate CDS IOC channels or isolated in the OFF position.

The front panels of both types contain a REMOTE-MANUAL toggle switch. When the switch is in the REMOTE position, the CSCP has control of the switch position (normal operating mode). When the toggle switch is in MANUAL, the switch must be positioned using the switch handle.

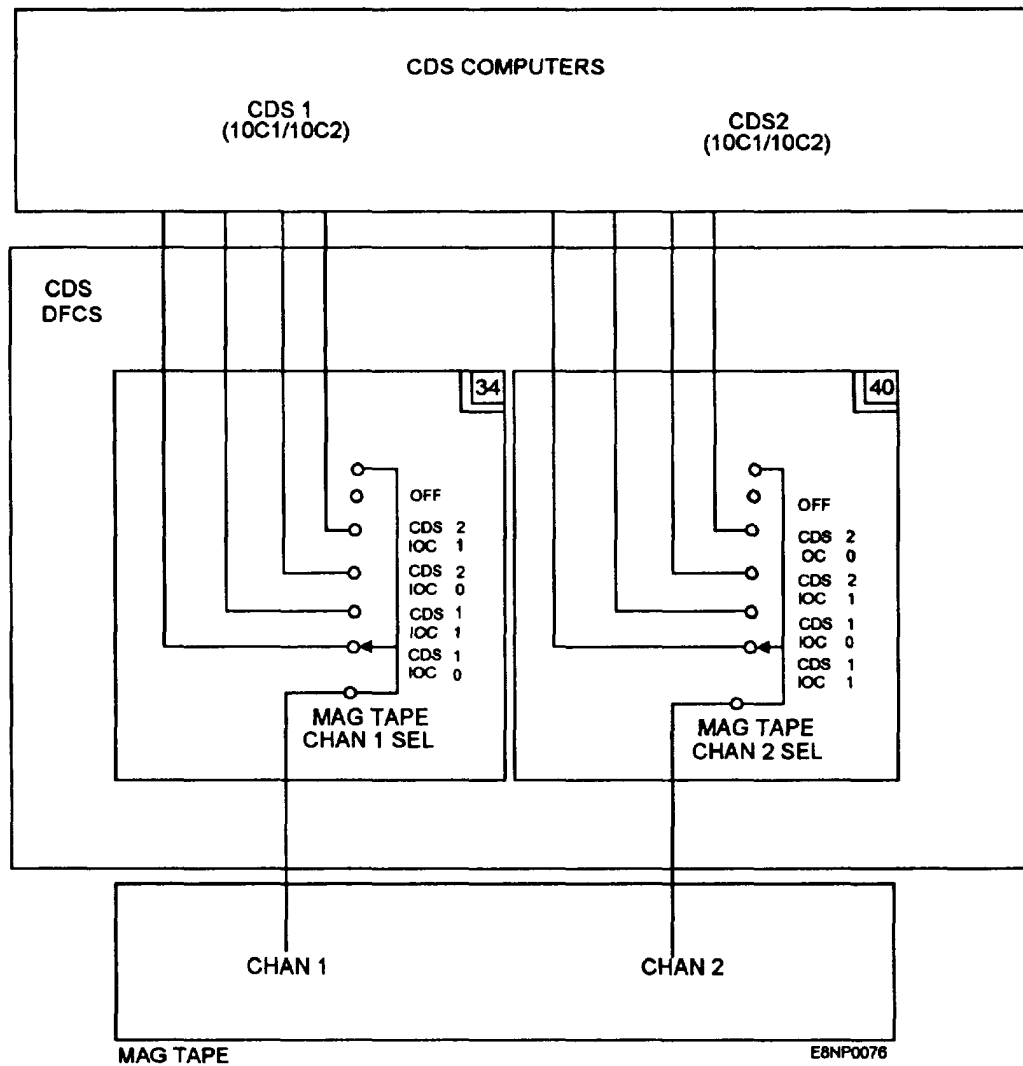


Figure 5-10.—Magnetic tape Interconnection through the DFCS.

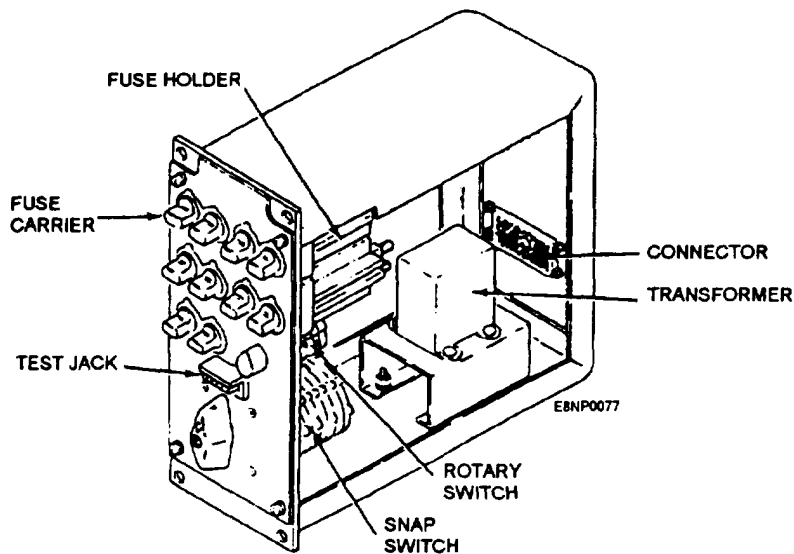


Figure 5-11.—Switch control and potential transformer ACO assembly.

### Switch Control and Potential Transformer ACO Assembly

The switch control and potential transformer action cutout (ACO) assembly (fig. 5-11) provides control voltages for bench testing of the linear movement switches. The control voltages are provided through test cables from the test jack to the linear switch assembly under test.

### Relay Tester Assembly

The relay tester assembly (fig. 5-12) provides the facilities for testing each and every type of relay used in the DFCS and the CSCPs. Relay sockets are provided for 8-, 10-, and 16-pin relays. The rotary switch is used to select the appropriate relay coil voltage. The toggle switch is used to energize/deenergize the relay coil. The

indicator lamps indicate the state of the relay under test (ENERGIZED/DEENERGIZED).

### Fuse Tester Assembly

The fuse tester assembly (fig. 5-13) is used to test fuses for continuity. The POWER ON PBI is used to apply power to the fuse tester. The POWER ON indicator will light when the tester is on. When a good fuse is placed across the contact strips, the CONTINUITY INDICATOR light will come on. A blown fuse placed across the contact strips will not light the indicator since there is no current path through the fuse.

### Computer Switching and Control Panel (CSCP)

The two computer switching and control panels (CSCPs) are used to make switch assignments on the

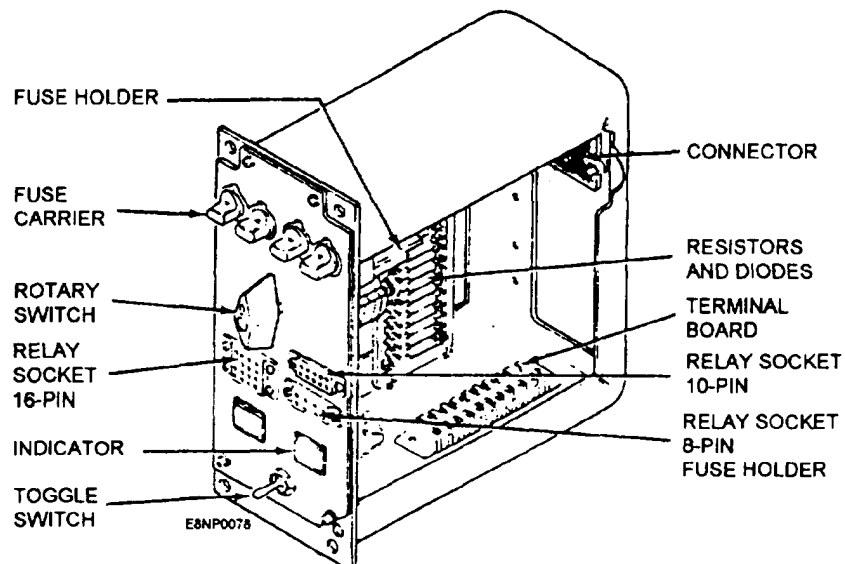


Figure 5-12.—Relay tester assembly,

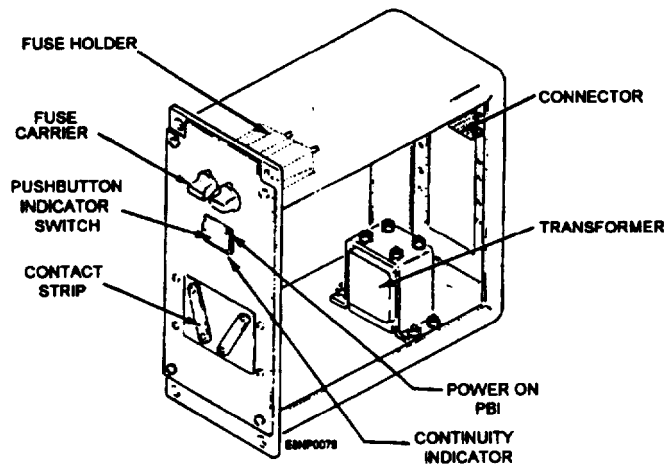


Figure 5-13.-Fuse tester assembly (DFCS).

DFCS (controlling CSCP front panel). Switch assignments are made by depressing the associated

Push-button/indicator (PBI) on the controlling CSCP front panel (fig. 5-14). The CSCP will generate a

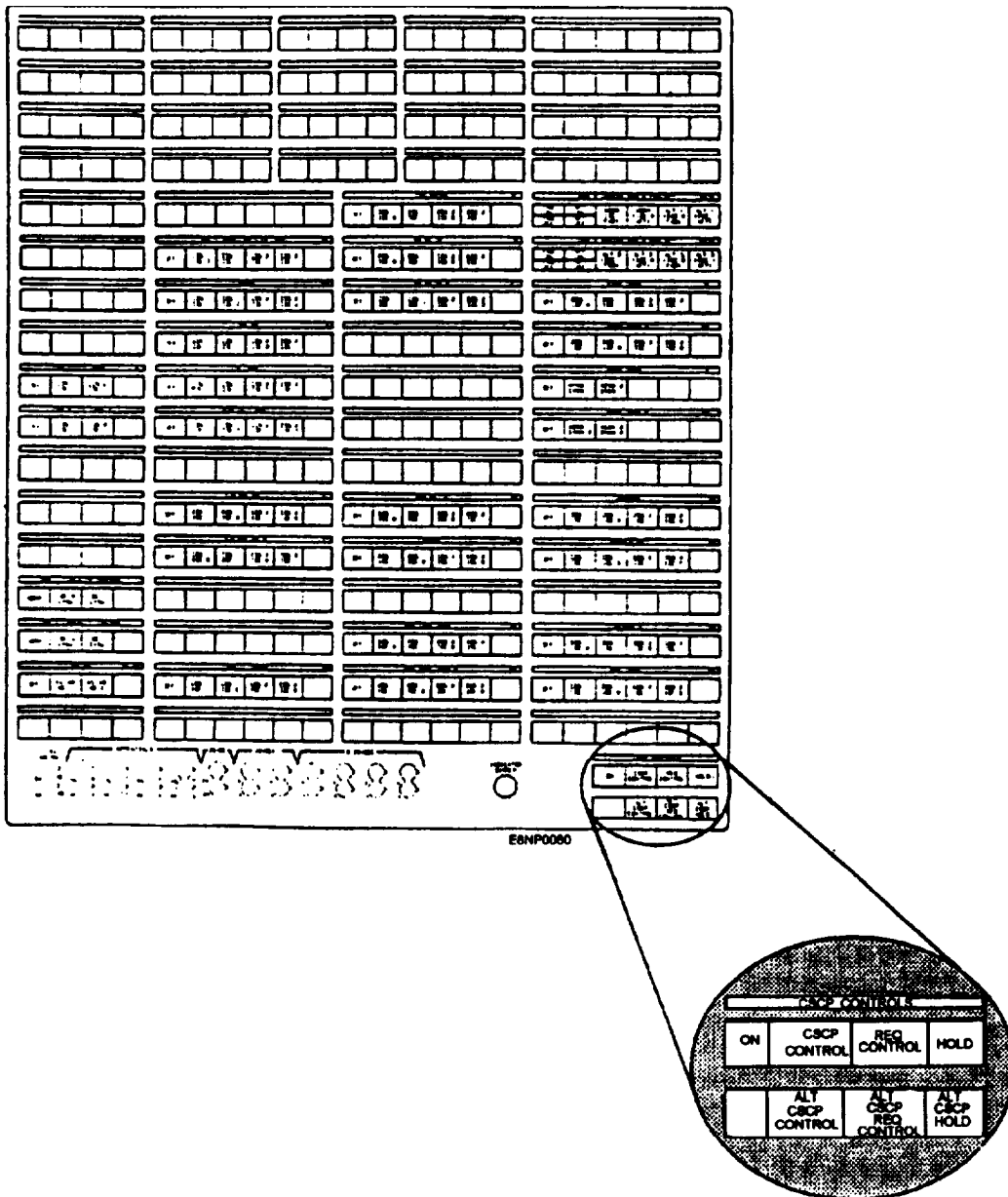


Figure 5-14.-CSCP controls and Indicators.

control signal to the appropriate DFCS linear switch assembly, which will respond with a status signal when it is in the assigned position. The PBI will light when the switch is in the commanded position.

Four colors are used for PBI indicators: white, red, green, and yellow. White indicates the linear slide switch position is in the ON position. Red indicates the switch is in the OFF position. Green indicates the switch is in the NORMAL position, while yellow indicates the switch is in the ALTERNATE position. Figure 5-14 shows an example of a typical CSCP configuration. The number and functional assignment of PBIs vary from ship to ship.

The PBIs in the lower-right corner of the CSCP front panel shown in figure 5-14 are used to apply power to the CSCP PBIs (ON), to indicate current CSCP control status (CSCP CONTROL or ALT CSCP CONTROL), and to transfer control from the controlling CSCP to the alternate CSCP (REQ CONTROL, HOLD, ALT CSCP REQ CONTROL, and ALT CSCP HOLD). Manual PBI actions are required at both CSCPs to transfer control between panels.

At the requesting CSCP, depression of the REQ CONTROL PBI will cause the ALT CSCP REQ CONTROL indicator to light red on the controlling CSCP. The REQ CONTROL PBI will flash red on the requesting CSCP until the operator of the controlling CSCP depresses ALT CSCP CONTROL PBI, giving control to the requesting CSCP. The CSCP CONTROL light will come on when the requesting CSCP is in control and the flashing light will go out. The HOLD PBIs are used to indicate refusal to transfer control.

**SHIP, SWITCHBOARD, AND  
COMPUTER SWITCHING  
CONTROL PANEL (CSCP)  
WIRING**

Switchboard and CSCP wires are those wires connecting assemblies and components inside the switchboard and CSCP. Ships cables are individually plug-connected to panel connectors in the switchboard. Ships cables are identified by a cable group number and cable type.

Ships cables, switchboard wires, and CSCP harness wires use plastic sleeves or metal tags for marking. Each ship wire has a marking bearing the wire number. When required, switchboard and CSCP wires have plastic marking sleeves at each end. The sleeves identify the terminals at both ends of the wire. Separate

wiring codes are used for ships wires, switchboard wires, and CSCP wires.

The ships wire marking codes are system oriented. They consist of an alphanumeric code that identifies the signal being carried by function number, circuit designation, and assigned wire number. Atypical ships wire code number is shown in table 5-1.

**Table 5-1.-A Typical Ships Wire Marketing Code Number**

<b>WIRE CODE NUMBER: 51-PD-713</b>		
<b>51</b>	<b>PD</b>	<b>713</b>
<b>FUNCTION NUMBER</b>	<b>CIRCUIT</b>	<b>WIRE NUMBER</b>

Eight types of PANEL ASSEMBLY connectors are used in the switchboard. These connectors are used for the linear movement switch assemblies, fuse tester assembly, relay tester assembly, and power distribution assembly. They consist of various types of 120-, 117-, 104-,85 -,38-,20-,10-, and 3-pin connectors. For wiring and maintenance purposes, a common alphanumeric designation system is used to identify specific circuit connections, as shown in table 5-2.

**Table 5-2.-Panel Connection Cable Code**

<b>PANEL CONNECTOR CODE: PP-36-D-C</b>			
<b>PP</b>	<b>36</b>	<b>D</b>	<b>C</b>
<b>PANEL CONNECTOR PLUG (PJ FOR JACK)</b>	<b>PANEL LOCATION</b>	<b>CONNECTOR LETTER</b>	<b>PIN LETTER</b>

Located within the switchboard are panels known as matrix panels. The matrix panels interconnect the signal paths between the ships wiring and the assembly panels. The designation codes for matrix panel connections are shown in table 5-3.

**Table 5-3.-Matrix Panel Connection Code**

<b>MATRIX PANEL CONNECTION CODE: JC-1-A-A</b>			
<b>JC</b>	<b>1</b>	<b>A</b>	<b>A</b>
<b>MATRIX PANEL DESIGNATOR</b>	<b>SECTION NUMBER</b>	<b>MODULE</b>	<b>CONNECTOR DESIGNATOR</b>

Intersection connectors are used to tie switchboard sections together. Intersection connector codes are identified in table 5-4.

Table 5-4.-Intersection Connector Code

INTERSECTION CONNECTOR CODE: JR-1-A-A			
JR	1	A	A
INTERSECTION CONNECTOR	SECTION NUMBER	MODULE	CONTACT DESIGNATOR

Table 5-5.-CSCP Connector Code

CSCP CONNECTOR CODE: JC-C	
JC	C
CSCP CONNECTOR DESIGNATOR	CONTACT DESIGNATOR

The CSCP uses two types of connectors, a 10-pin connector and an 85-pin connector. The 10-pin connectors are designated JA, JB, JN, and JP. The 85-pin connectors are designated JC through JG, JH, and JK. The alphanumeric identification shown in table 5-5 is used for CSCP connectors.

## ANALOG SWITCHBOARDS

Analog switchboards are similar design to the Mk 70 DFCS. The switchboard is made up of a variable number of switchboard sections. The number of sections required will vary with the analog interface requirements of the shipboard system.

Each switchboard section consists of front and rear cabinets (fig. 5-15). The front cabinet contains the panel assemblies. The rear cabinet contains removable modules on which are mounted the ships cable connectors.

Each switchboard section contains 36 panels of various types mounted on the door of the front cabinet. The panels are numbered starting with panel 1 in the upper left-hand corner in section 1 and progress consecutively downward in each column and successively to the right. The door in each switchboard section allows access to the section interior.

Ships cables enter the switchboard through the rear cabinet and connect to the front of the module terminal

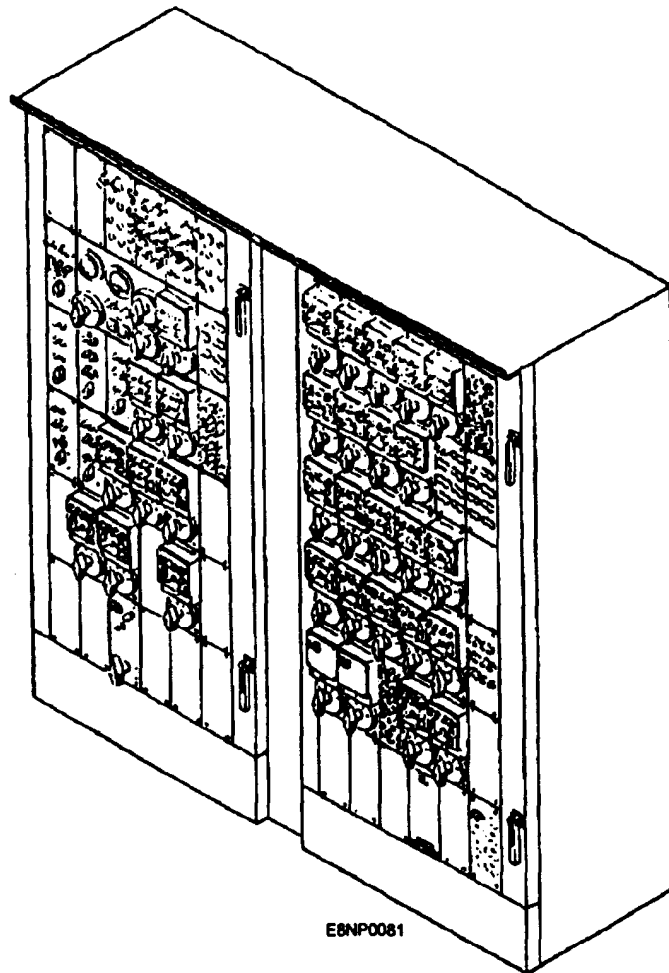


Figure 5-15.-Analog switchboard.

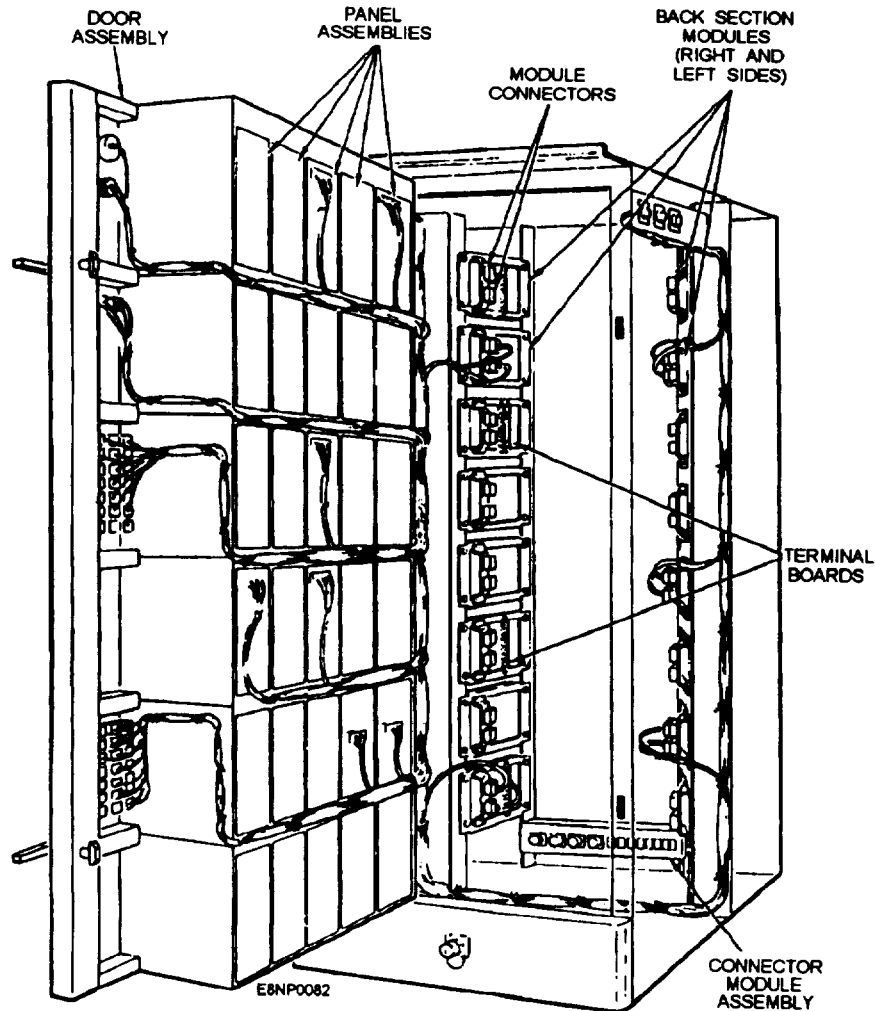


Figure 5-16.—Analog switchboard section, door open.

boards (fig. 5-16). From the panel assemblies, wiring is routed to the back side of the terminal boards on the modules via plug connectors. Wiring between switchboard sections is routed via inter-section connectors.

Two following panel assemblies are found on analog switchboards. Individual analog switchboard layouts and configurations will vary between ship classes.

#### Indicator Panel Assembly

The indicator panel assembly (fig. 5-17) provides a visual indication of the active power being supplied to the switchboard. The panel assembly contains up to 10 indicators, all of which are mounted on the front panel.

#### Fuse Panel Assembly

The fuse panel assembly (fig. 5-18) contains overflow fuses for circuits located in an associated panel. Each panel may contain up to 10 dual indicator-type fuseholders.

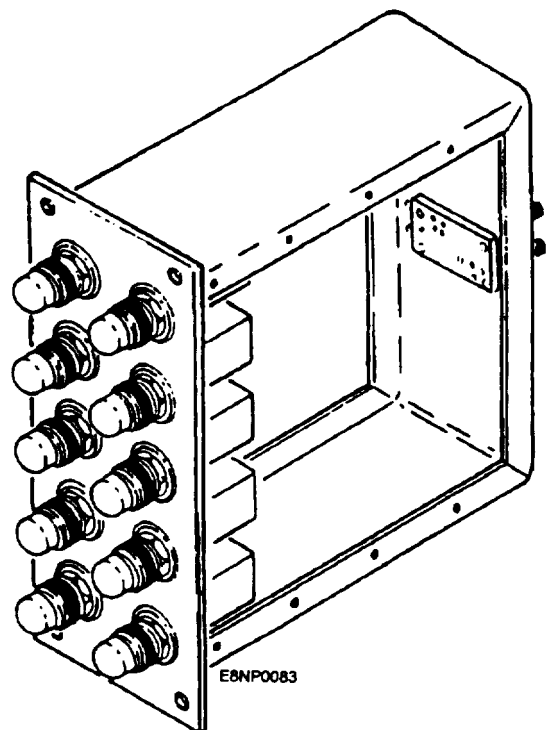


Figure 5-17.—Indicator panel assembly.

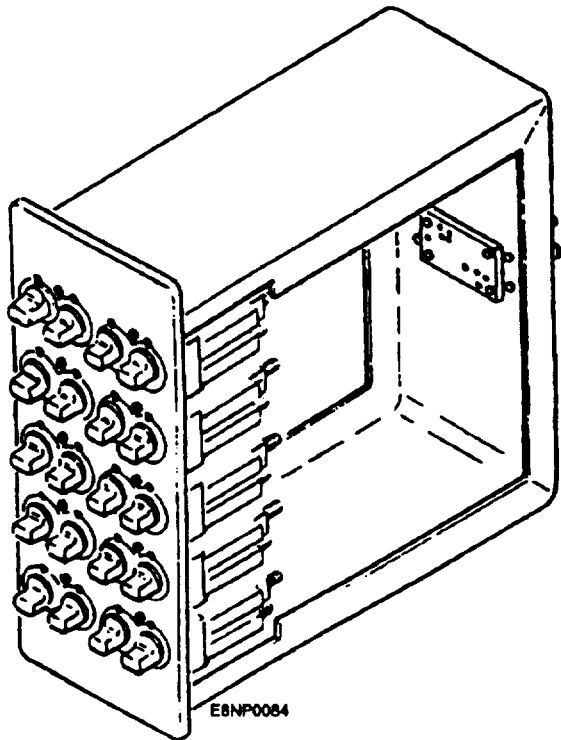


Figure 5-18.-Fuse panel assembly.

#### Fuse Tester Panel Assembly

The fuse tester panel (fig. 5-19) functions in the same manner as the Mk 70 DFCS fuse tester panel.

#### Meter Panel Assembly

Two meter panels (fig. 5-20) are used one panel type monitors 60-Hz and 400-Hz power buses, and the

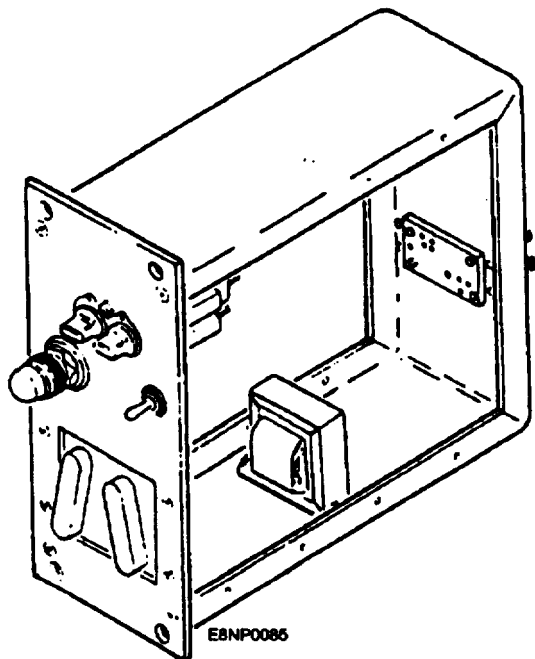


Figure 5-19.-Fuse tester assembly (analog switchboard).

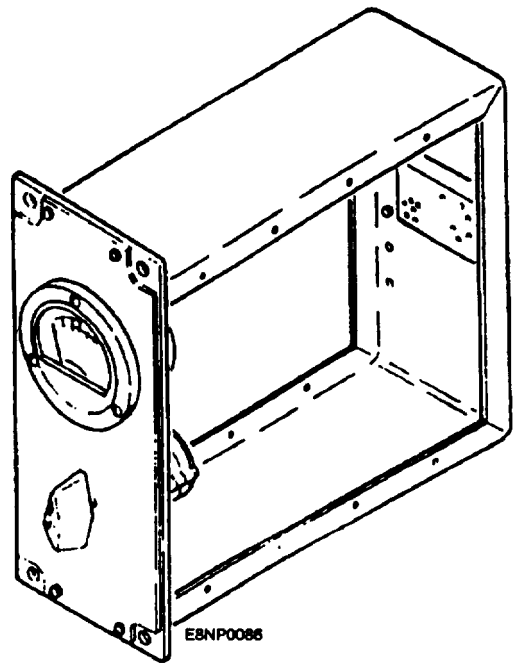


Figure 5-20.-Meter panel assembly.

other panel type monitors dc buses. The panels contain an ac or dc meter and a rotary snap switch. The snap switch enables voltage measurements to be performed on the selected power bus.

#### Flasher Panel Assembly

The flasher panel (fig. 5-21) produces pulsating (ON/OFF/ON and so forth) potentials to activate

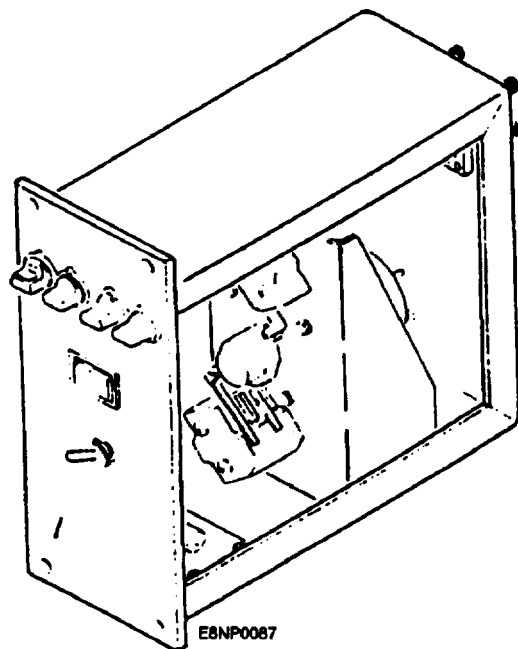
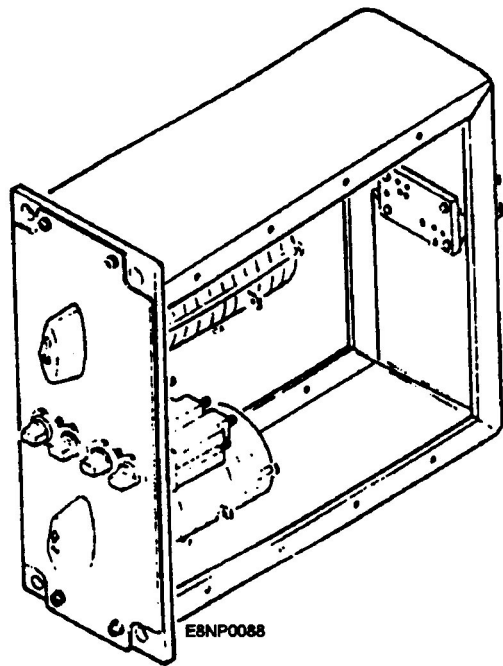


Figure 5-21.-Flasher panel assembly.



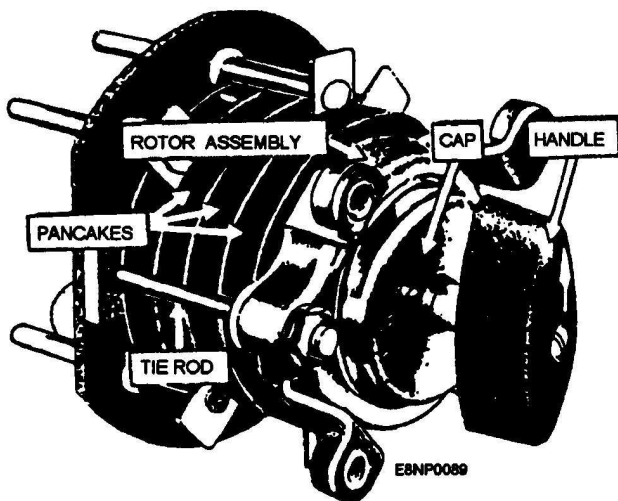
**Figure 5-22.-Snap switch panel assembly.**

flashing system indicators when a warning or emergency condition occurs. Motor-driven dual-cam and three-cam activated switches open and close control or status signal circuits to provide the flashing effect on indicator lamps.

### **Snap Switch Panel Assembly**

The snap switch panel assembly (fig. 5-22) provides manual control of switchboard power buses. An individual panel mat contains either one or two snap switches.

The snap switch (fig. 5-23) is a device that opens or closes a circuit with a quick motion. Rotary snap



**Figure 5-23.-Snap switch.**

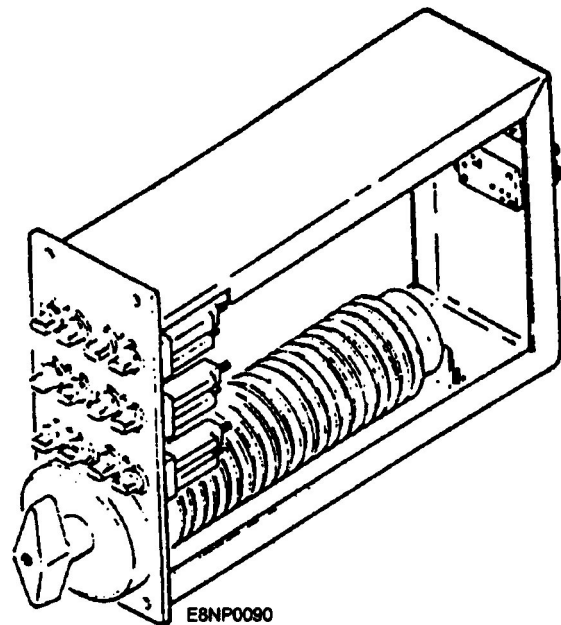
switches are used extensively in the distribution sections of switchboards to connect the shipboard power supplies to the various switchboard power buses.

### **Manually Operated JR Switch Panel Assembly**

The manually operated JR switch panel assembly (fig. 5-24) provides manual switching and action cutout (ACO) functions. The manually operated JR switch panel assembly uses either a 2JR or 4JR switch. Both switch types are similar in construction and differ only in the electrical application because of switching action. A JR switch as shown in figure 5-25 is made up of a variable number of wafer-like sections. As the switch is manually positioned, one or more moveable contacts are positioned to each switch position on the wafer. The contacts may connect (bridge) two or more contacts on each wafer effectively opening or closing circuit paths as required to configure the system for normal or alternate operation.

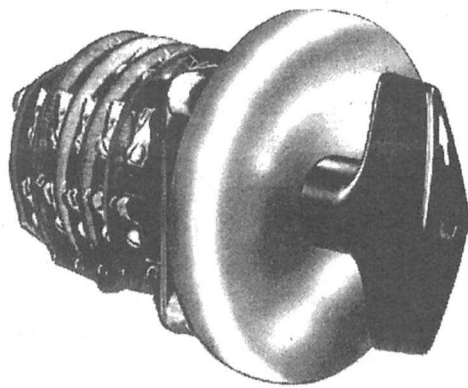
### **Remotely Operated JR Switch Panel Assembly**

The remotely operated JR switch panel (fig. 5-26) provides remote and manual control of signal routing and ACO switching. The automatic junction rotary (AJR) switches used in these assemblies are driven by a motor and gear train servo system. The automatic switches allow control of switching functions from remote stations. Analog switchboards used with combat

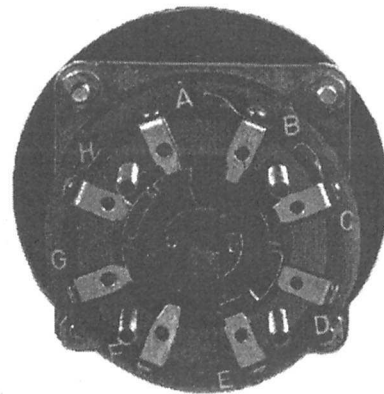


**Figure 5-24.-Manually operated JR switch panel assembly.**





**FRONT VIEW**



**REAR VIEW**

**Figure 5-25.-JR Switch (type 4).**

direction systems use control signals provided by the multiplexing data converter to activate the switches and provide status signals back to the converter to indicate switch position to the system.

Each panel contains a REMOTE-MANUAL toggle switch. The servo system controls the position of the AJR switch when the toggle switch is in the REMOTE position. The toggle

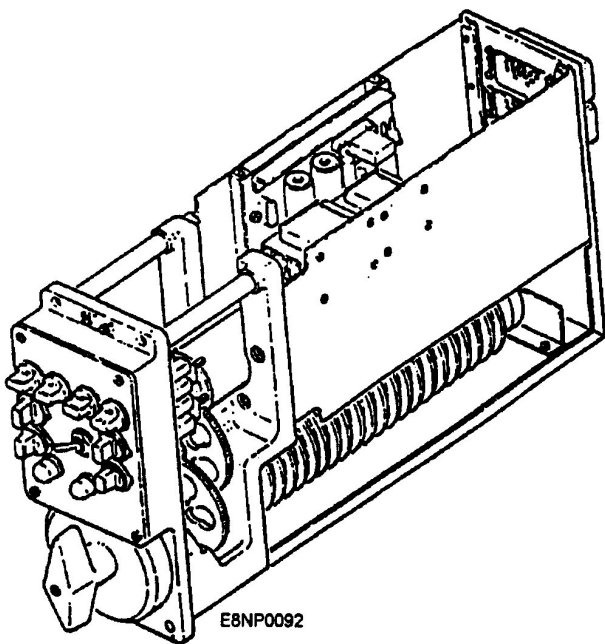
switch must be placed MANUAL to allow personnel to rotate the switch

**Linear Movement Switches**

In newer switchboards and upgrades to older switchboards, the rotary-type JR and AJR switches have been replaced by linear movement switches with the same electrical configurations as the JR switches. We covered linear movement switch panel assemblies in the Mk 70 DFCS.

**END-AROUND-TEST**

One of the functions provided by both analog and digital switchboards is the end-around-test (EAT). When switches are in the EAT position, switchboards take the output of a device and feed it back to the same or similar device as input data. For instance, a control signal generated by a device such as the keyset central multiplexer (KCMX) can be routed end-around as a status signal input. The output of a digital-to-synchro (D/S) converter can be fed end-around to a synchro-digital (MD) converter or the output channel of a computer can be end-around as an input channel for the same computer. EAT allows for offline testing and verification of the operability of digital and analog interfaces, both within the CDS and external to the CDS.



**Figure 5-26-Remotely operated JR switch panel assembly.**

## RADAR SWITCHBOARDS

The **SB-4229/SP** switchboard, shown in figure 5-27, replaces all **SB-440**, **SB-1109**, and **SB-1505** switchboards. It provides selectable distribution of data from any Navy conventional search radar set. The digitally-controlled switchboard can accept signals from five radar sets and four **IFF** interrogator sets. It will then distribute them to six individual radar indicators and six **IFF** decoders. It can also accept mode control from any **IFF** decoder associated with any of the radar indicators and switch the mode control of the **IFF** interrogator associated with the radar set being viewed on that indicator.

The **SB-4229/SP** switchboard allows radar and **IFF** signals from ship's radar and **RDDS** (Radar Display and Distribution System) inputs to be selected from up to 16 signal data converters. It provides up to nine selectable outputs to the **AN/SPA** series radar indicators. So, up to nine different operators can select one of 16 input sensors to display at their indicator. Each of the 16 input sensors can consist of three radar videos, **RDDS** (data stream), and **IFF** control with its associated videos. The more significant design features include:

- Local or remote selection of input sensors
- Conversion of **RDDS** (data stream) back to analog (for older indicators)
- Distribution of any of the 16 input sensors to any of up to nine separate radar indicators
- Detection of improper operation by self-test (**BIT**)

### Signal Data Converter

The Signal Data Converter, **CV-3989/SP** (**SCV**), shown in figure 5-28, is designed for installation inside the shipboard radar room. It is mated to the radar (triggers), antenna azimuth, ship's gyro-heading, and ship's speed or distance (ship's pit log).

The **SCV** conditions and multiplexes the various data inputs into a single digital data stream. This permits a single cable to distribute **RDDS** stream data throughout the ship. Some of these systems include:

- Radar trigger(s)
- Radar antenna azimuth (stabilized and unstabilized)

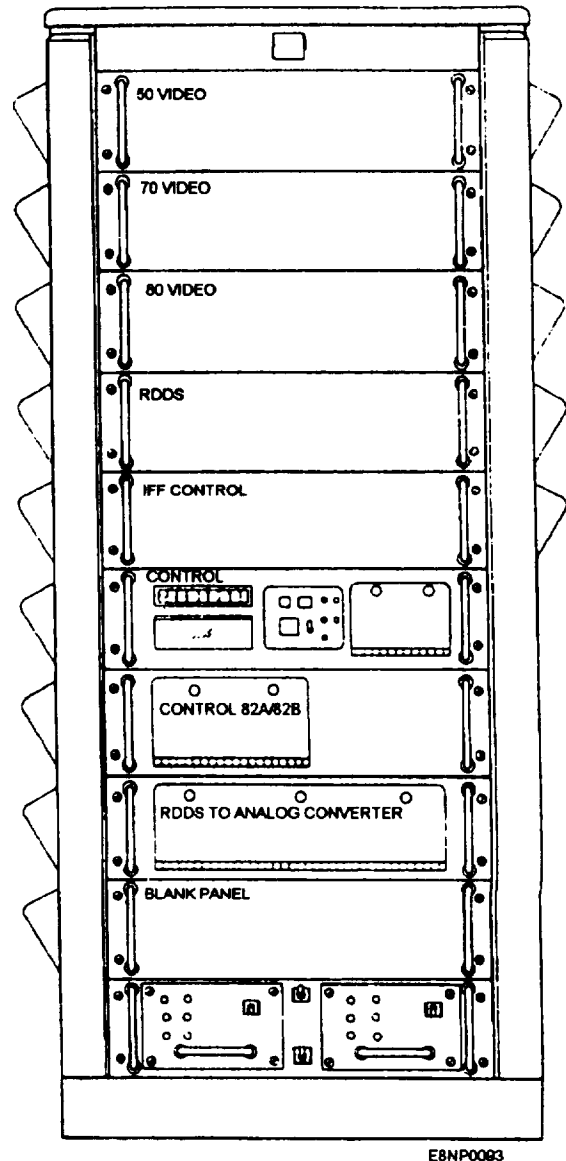


Figure 5-27.—Radar Distribution Switchboard, **SB-4229/SP**.

- Dead reckoning information
- Ship's heading
- Radar set sensor ID

The **SCV** also contains the necessary circuitry for future growth and expanded use in data distribution. A compatible switchboard is required to interface the data from various radar sets with other systems.

### Maintenance

The maintenance of the **CV-3989/SP** and the **SB4229/SP** is performed by the Electronics Technician (**ET**) assigned maintenance responsibilities for the

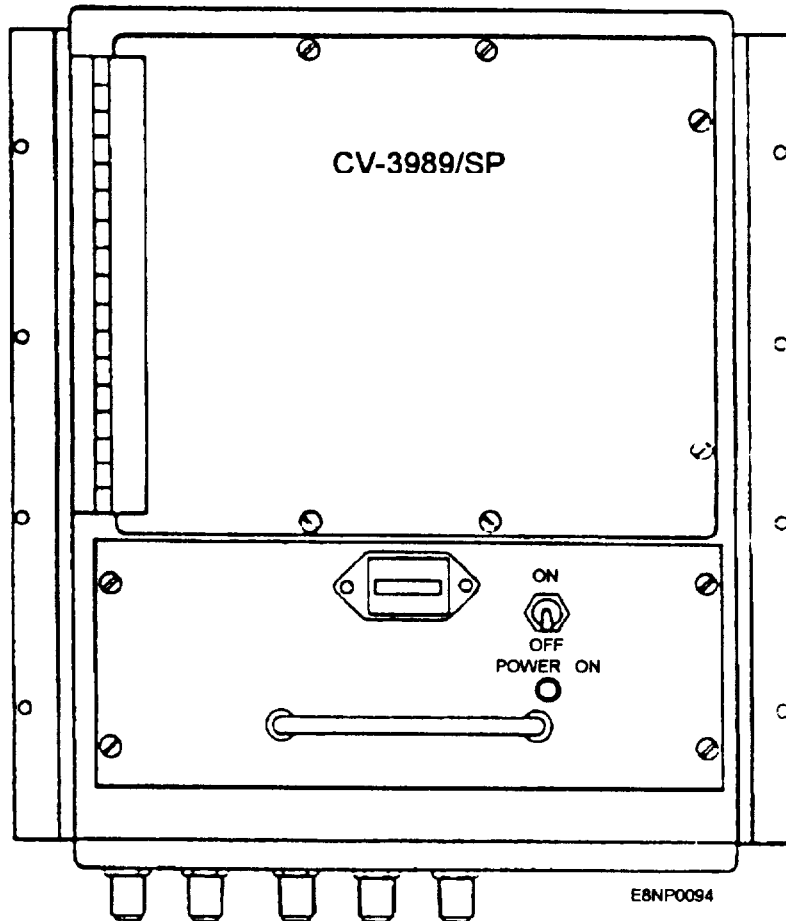


Figure 5-28.-Signal Data converter, CV-3989/SP

surface search radar or conventional radar display and distribution systems.

Organizational maintenance consists of corrective and preventive maintenance actions. Preventive maintenance is performed according to the maintenance requirement cards (MRCs).

Shipboard personnel perform corrective maintenance (CM) according to the corrective maintenance sections of the applicable technical manuals and as reflected by the maintenance code assigned in the equipment APL. CM may require (1) removal or replacement of cabinet mounted piece parts; (2) replacement of components, assemblies, or sub-assemblies; or (3) repair of certain units, assemblies or sub-assemblies designated as "shipboard repairable." It may then require "turn in" of depot repairable assemblies or sub-assemblies through prescribed supply procedures.

All replaceable modules, assemblies, or printed circuit boards with a high-cost replacement value (except the CRT and high-voltage power supplies) are

designed and constructed to be repairable to component level replacement.

### TRANSMITTER TRANSFER SWITCHBOARD

The Transmitter Transfer Switchboard SB-988/SRT allows the remote control station functions and signals to be transferred selectively to the transmitters. Figure 5-29 shows a transfer switchboard that allows the functions and controls of any one, or all, of 10 remote control station functions and signals to be transferred selectively to any one of six transmitters. Each knob corresponds to a remote control station and has 8 operating positions. Positions 1 through 6 correspond to attached transmitters. The seventh position (x) allows for switching of the transmitters to another switchboard. The eighth position (OFF) removes the remote from the system.

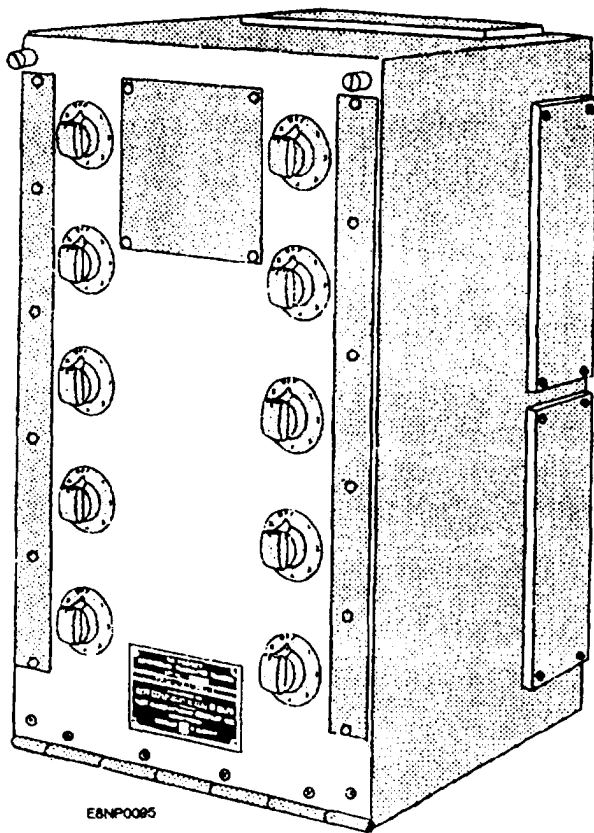


Figure 5-29.—Transmitter Transfer Switchboard.  
SB-988/SRT.

### RECEIVER TRANSFER SWITCHBOARD

The receiver switchboard SB-973/SRT allows the audio outputs from the receivers to be transferred to remote control station audio circuits. A representative receiver transfer switchboard is shown in figure 5-30. This switchboard contains 10 seven-position switches. Each switch corresponds to a remote control station and each switch position (1 through 5) represents a receiver. Position X allows the circuits attached to the switch to be transferred to another switchboard

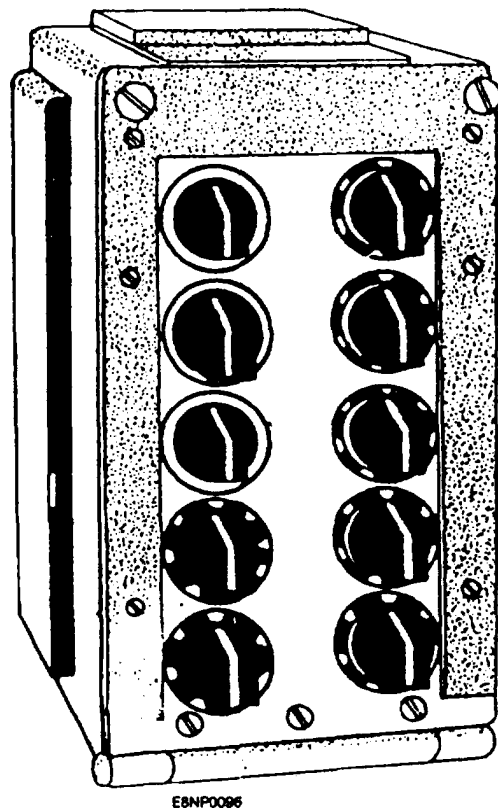


Figure 5-30.—Receiver Transfer Switchboard, SB-973/SRT.

### SUMMARY

In this chapter, you have been introduced to the various types of information transfer systems. You have studied the function and operation of digital switchboards, digital fire control switchboards, analog switchboards, radar switchboards, transmit and receiver transfer switchboards, and maintenance responsibilities of these equipments. These topics have provided you with the fundamental knowledge of their operation so that you will be better prepared to help maintain these systems aboard your ship. For more detailed explanation of specific equipment or system, consult the manufacturer's technical manual.

# APPENDIX I

## GLOSSARY

- A**
- A/D**—Analog-Digital.
- ABSORPTION**—A taking in and not reflecting of any substance.
- ABT**—Automatic bus transfer.
- AC**—Alternating current.
- ACCELEROMETER**—an instrument that measures one or more components of the changes in speed of a moving body in which the instrument is contained.
- ACO SWITCH**—Action cutout switch.
- ACTIVATED CHARCOAL**—A form of highly porous carbon that can easily absorb gases, vapors, and colloidal particles.
- ADSORPTION**—Adhesion of the molecules of a gas, liquid, or dissolved substance to a surface.
- AJR**—Automatic Junction Rotary switch.
- ALT**—Alternate.
- AMPERE**—The basic unit of electrical current.
- ANODE**—A positive electrode of an electrochemical device toward which negative ions are drawn.
- ARC**—The band of sparks or incandescent light formed when an electrical discharge is conducted from one electrode or conducting surface to another, characterized by high current and low voltage.
- ARMATURE**—The rotating part of an electric motor or generator. The moving part of a relay or vibrator.
- ATMOSPHERIC PRESSURE**—The pressure due to the weight of the earth's atmosphere: one standard atmosphere equals 14.69 lb. per sq. in. of pressure.
- AZIMUTH**—Angular measurement in the horizontal plane in a clockwise direction.
- B**
- BEARING**—An angular measurement that indicates the direction of an object in degrees from true north. Also called azimuth.
- BIT**—Built In Test.
- BUS**—A conductor or group of conductors serving as a common connection in any high current application.
- C**
- CAPILLARY TUBE**—A tube with a very small bore.
- CDS**—Combat direction system.
- CHILLED WATER**—Water from the ship's air-conditioning plant. Used in a cooling system's primary loop.
- CHLORINE**—A gaseous element, symbol C. Atomic number is 17.
- CLOSED-LOOPED**—A seawater system in which the distilled water is recirculated.
- CIC**—Combat information center.
- COMPRESSED AIR**—Air reduced in volume by pressure and held in a container.
- CONDUCTANCE**—The reciprocal of the resistance of a material and is measured in mhos or siemens.

**CONVECTION**—The transfer of heat by its absorption by a fluid at one point followed by motion of the fluid and rejection of the heat at another.

**COSAIL**—Coordinated shipboard allowance list.

**CORRECTIVE MAINTENANCE**—Maintenance specifically intended to eliminate an existing fault.

**CSCP**—Computer switching control panel.

**CW**—Chilled Water.

**CW/DW**—Chilled water/distilled water.

## **D**

**DATA**—A representation of facts, concepts, or instructions in a formalized manner suitable for communication, interpretation, or processing by humans or by automatic means.

**DC**—Direct current, a current that flows only in one direction.

**DCA**—Damage control assistant.

**DELTA CONNECTED**—A three-phase connection in which windings are connected end-to-end, forming a closed-loop that resembles the Greek letter delta. A separate wire is then connected to each of the three junctions.

**DESICCANT**—A drying agent.

**DEWPOINT**—Temperature at which a condensable component of a gas starts to condense into liquid.

**DFCS**—Digital fire control switchboard.

**DIGITAL**—Pertaining to data in the form of digits.

**DISTILLED WATER**—Demineralized or ultrapure water. Used in a cooling system's secondary loop.

**DRY AIR**—Air in which moisture has been removed.

**D/S**—Digital to synchro conversion.

**DUPLEX**—Double or twofold.

**DWELL**—A timed delay of programmed or established duration, not cyclic or sequential.

## **E**

**EAT**—End-around test.

**EDDY CURRENT**—Induced circulating currents in a conducting material caused by a varying magnetic field.

**ELECTRODE**—The terminal at which electricity passes from one medium into another.

**ELECTROLYTE**—A solution of a substance that is capable of conducting electricity. An electrolyte may be in the form of either a liquid or a paste.

**ELECTROMAGNETIC INDUCTION**—The production of a voltage in a coil due to a change in the number of magnetic lines of force passing through the coil.

**ENTRAINED**—A liquid in the form of fine droplets.

**ETHYLENE GLYCOL**—A colorless, viscous liquid, used as an antifreeze.

## **F**

**FLUX FIELD**—A general term used to designate collectively all the electric or magnetic lines of force in a region.

## **G**

**GPM**—Gallons per minute.

**GYROSCOPE**—wheel or disc so mounted as to spin rapidly about one axis and be free to move about one or both of the two axes mutually perpendicular to the axis of spin.

## **H**

**HEADING**—Horizontal direction in which an object is moving.

**HERMETICALLY SEALED**—Completely sealed so as to keep air or gas from getting in or out.

HERTZ—International unit of frequency, equal to one cycle per second.

## I

IMPINGEMENT—To have an effect on the property or rights of another.

IN-PHASE—This term is applied to the condition that exists when two of the same frequency pass through their maximum and minimum values of like polarity at the same instant.

I/O—Input/Output.

IOC—Input Output Controller.

## J

JOULE—A unit of energy or work. A joule of energy is liberated by 1 ampere flowing for 1 second through a resistance of 1 ohm.

JR—Junction Rotary switch.

## K

KILOWATT—A unit of electrical power, equal to 1,000 watts.

## L

LINEAR—Straight line relationship where changes in one function are directly proportional to changes in another function.

LINES OF FORCE—A line in an electric or magnetic field that shows the direction of the force.

## M

MAKEUP WATER—Distilled water that is added to the expansion tank when level becomes too low.

MERIDIAN—True North.

MICRON—A unit of length equal to  $10^{-6}$  meter. Also called a micrometer.

MRC—Maintenance Requirement Card.

## N

NAVSAT—Naval Satellite.

NAVSTAR—Naval Global Positioning System Satellite.

NAVSEA—Naval Sea Systems Command.

## O

OPEN-LOOPED—One-pass, a seawater system in which the seawater flows through the system only once.

## P

PBI—Push-button indicator.

PITCH—Degree of slope or inclination.

POLY-PHASE—Having, generating or used in generating currents consisting of three or a multiple of three phases.

PM—Planned Maintenance.

PMS—Planned Maintenance System.

PSIG—Pounds-per-square inch gage.

## R

RADAR—Radar Detection and Ranging.

REQ—Request.

ROLL—To move gently around and around or from side to side.

## S

SEAWATER—Water that is drawn from the sea by the ship.

SERVO—A device used to convert a small movement into one of greater movement or force.

SINGLE-PHASE—Having, generating, or using a single alternating current, either in phase or  $180^\circ$  out of phase.

SONAR—Sound Navigation and Ranging.

STAR CONNECTED—Shaped like the letter Y.

SUBMICRON—Less than one millionth of a meter.

SW/DW—Seawater/distilled water.

SYNCHRO—A small motor-like analog device that operates like a variable transformer and is used primarily for the rapid and accurate transmission of data among equipments and stations.

## T

TEMPERATURE GRADIENT—The rate of temperature change between the primary inlet temperature and the secondary outlet temperature.

TEMPERATURE COEFFICIENT—The amount of change of resistance in a material per unit of change in temperature.

TRUE BEARING—Angle between a target and true north measured clockwise in the horizontal plane.

TRUE NORTH—Geographic North.

## V

VENTURI-TYPE—Having a throat-like passage that increases the velocity and lowers the pressure of a fluid conveyed through it.

## W

WATERBOX—A part of the heat exchanger, also called the bonnet. Installed at the end of the heat exchanger to access the tubes for cleaning.

WATT—International unit of power, equal to one joule per second.

WYE CONNECTED—A three-phase connection in which each winding is connected to a common ground forming a connection that resembles the letter Y.

## Z

ZINC ANODE—Disks, rods, bars, or plates made of zinc metal and installed in the heat exchangers water box.



## APPENDIX II

### REFERENCES USED TO DEVELOP THIS TRAMAN

Shipboard Electronics Material Officer, NAVEDTRA 12969, Naval Education and Training Program Management Support Activity, Pensacola FL, 1992.

*Fire Controlman Third Class*, NAVEDTRA 102761, Naval Education and Training Program Management Support Activity, Pensacola FL, 1988.

*Fire Controlman Second Class*, NAVEDTRA 10277, Naval Education and Training Program Management Support Activity, Pensacola FL, 1985.

Data Systems Technician Training Series, Volume 2, *Computer Fundamentals and Interfacing*, NAVEDTRA 12502, Naval Education and Training Program Management Support Activity, Pensacola FL, 1992.

Data Systems Technician Training Series, Volume 3, *Data Storage and Conversion Devices*, NAVEDTRA 12503, Naval Education and Training Program Management Support Activity, Pensacola FL, 1994.

*Interior Communications Electrician*, Volume 1, NAVEDTRA 12106, Naval Education and Training Program Management Support Activity, Pensacola FL, 1994.

*Interior Communications Electrician*, Volume 2, NAVEDTRA 12161, Naval Education and Training Program Management Support Activity, Pensacola FL, 1993.

*Electrician's Mate 3 & 2*, NAVEDTRA 10546-F, Naval Education and Training Program Management Support Activity, Pensacola FL, 1988.

Technician's Handbook *Basic Liquid Cooling Systems For Shipboard Electronics*, NAVSEA 0948-LP-1228010, Naval Sea Systems Command, Washington, DC, 1977.

Naval Ship's Technical Manual, Chapter 320, *Electrical Power Distribution Systems*, NAVSEA 0901-LP-320-0010, Naval Sea Systems Command, Washington, DC, 1991.



# INDEX

## A

Absorption, 2-4  
AC generators, 3-8  
Action cutout switching (ACO), 5-1  
Adjusting screw, 1-16  
Adjusting spring, 1-14, 1-15  
Adsorption, 2-4  
Air-to-air cooling, 1-2  
Air-to-liquid cooling, 1-3  
AN/WSN-2 stabilized gyrocompass, 4-4  
AN/WSN-5 inertial navigation set, 4-6  
Analog switchboards, 5-11  
Armored capillary tube, 1-14  
Audible silence alarm, 1-23  
Automatic bus transfer (ABT) switches, 3-4

## B

Baffle, 1-8  
Ball-check, 2-7  
Bonnet, 1-8  
Bulb, 1-13  
Bus transfer switches, 3-3  
By-pass valve, 1-13, 1-18

## C

Casualty power distribution system, 3-13  
Cell select switch, 1-21  
Central dry-air system, 2-2  
Centrifugal pump, 1-19  
Check valve, 2-3  
Circuit markings, 3-2  
Circulating pump, 1-19  
Compression tank, 1-6  
Computer switching and control panel (CSCP), 5-3  
Conductivity cell, 1-20  
Constant flow regulator, 1-15  
Convection coding, 1-1  
Cooler, 1-13  
Cooling system alarm switchboard, 1-23

Cooling system components, 1-7  
Cooling system flow switch, 1-17  
Cooling system, Type I, 1-7  
Cooling system, Type II, 1-7  
Cooling system, Type III, 1-7

## D

Dehydrator, 2-7  
Delta connection, 3-9  
Demineralize, 1-20  
Desiccant chambers, 2-7  
Diaphragm, 1-16, 1-17  
Diaphragm chamber, 1-16  
Digital fire control switchboard (DFCS), 5-1  
Digital Switchboards, 5-1  
Dome, 2-4  
Dome gasket, 2-6  
Drain, 1-10  
Dry-air systems, 2-2  
Dryer components, 2-4  
Dust filter, 2-3  
Dump trap, 2-5

## E

Electrical distribution system, 3-1  
Electronics dry-air, 2-1  
Electronic equipment cooling methods, 1-1  
End around test, 5-15  
Equipment dry-air, 2-2  
Expansion tank, 1-10

## F

400 HZ power distribution, 3-12  
Finned heat sink, 1-1  
Flasher panel assembly, 5-13  
Flow limiter, 2-8  
Flow monitoring devices, 1-17  
Flow regulators, 1-15  
Fluid separator, 2-4

Forced air cooling, 1-2  
Fuse panel assembly, 5-12  
Fuse tester assembly, 5-8  
Fuse tester panel assembly, 5-13

## G

Ground detector circuits, 3-7  
Gyrocompass systems, 4-1

## H

Honeycomb rf interference filter, 1-2

## I

Indicator panel assembly, 5-12

## J

JR switch panel assembly, 5-14  
Manually operated JR switch panel, 5-14  
Remotely operated JR switch assembly, 5-14

## L

Linear movement switch assemblies, 5-4  
    R3DLSO-1B/R5DLSO-1B, 5-6  
    R3BLSO-1C/R5BLSO-1C, 5-6  
Linear movement switches, 5-15  
Liquid cooling, 1-3

## M

Manifold, 2-7  
Manual bus transfer (MBT) switches, 3-3  
Manual switchboards, 5-1  
Manually operated JR switch panel assembly, 5-14  
Remotely operated JR switch panel assembly, 5-14  
Mk 19 gyrocompass, 4-1  
Mk 23 gyrocompass, 4-2  
MK 27 gyrocompass, 4-4  
Meter panel assembly, 5-13  
Muffler, 2-7

## O

Oxygen analyzer, 1-22

## P

Phase sequence, 3-3  
Phase sequence indicator, 3-18  
Polarity marking of power transformers,  
    3-11  
Power distribution panel, 5-4  
Pressure regulator, 2-6  
Primary Cooling System, 1-5  
Purity meter, 1-21

## R

Radar switchboards, 5-16  
Receiver transfer switchboard, 5-18  
Relay tester assembly, 5-8  
Remotely-controlled switchboards, 5-1  
Resistivity verses conductivity data, 1-22  
Rigging casualty power, 3-14  
Rigging shore power, 3-17  
Rotameter, 1-18  
Rodmeter, 4-7

## S

Sea valve  
Seawater strainers, 1-11  
Sensor probe, 2-9  
Ship's service switchboards, 3-4  
Ship, switchboard, and CSCP wiring, 5-10  
Shore power, 3-16  
Signal data converter, 5-16  
Snap switch panel assembly, 5-14  
Solenoid valve, 2-7  
Submicron filter, 1-20  
Switch control and potential transformer  
    ACO assembly, 5-8  
Switchboards, 5-1  
Synchro signal amplifiers, 4-5  
Synchro signal converter, 4-6

**T**

Telltale oil filter, 2-5  
Temperature regulating valves, 1-12  
Three-phase generators, 3-8  
Three-way temperature regulating valve, 1-12  
Transformers, 3-9  
Transmitter transfer switchboard, 5-17  
Two-way temperature regulating valve, 1-14  
Types of liquid cooling systems, 1-3  
Type I liquid cooling system, 1-7  
Type II liquid cooling system, 1-7  
Type III liquid cooling system, 1-7  
Types of transformers construction, 3-10

**U**

Underwater log system, 4-7  
Unrigging casualty power, 3-16  
Unrigging shore power, 3-18

**V**

Venturi-type flowmeter, 1-18

**W**

Waveguide flooding, 1-24  
Wye connection, 3-8



---

---

# *Assignment Questions*

---

---

**Information:** The text pages that you are to study are provided at the beginning of the assignment questions.





# ASSIGNMENT 1

Textbook Assignment: "Liquid Cooling Systems," chapter 1, pages 1-1 through 1-24. "Dry Air Systems," chapter 2, pages 2-1 through 2-9.

---

---

Learning objective: Identify and describe the liquid cooling system components and their operation.

---

- 1-1. Three of the four methods of cooling are forced-air, air-to-air, air-to-liquid. What is the fourth?
1. Circulation
  2. Convection
  3. Conversion
  4. Convection
- 1-2. When utilizing forced-air cooling, an air filter must be provided at the air outlet to remove dust and dirt from the exhaust air.
1. True
  2. False
- 1-3. Heat is removed from the air passing by the heat producing source in an air-to-air cooling system by forcing it through what component?
1. Blower
  2. RF filter
  3. Heat exchanger
  4. Fins
- 1-4. Efficiency is increased in an air-to-liquid cooling system by the use of what system component?
1. Liquid heat exchangers
  2. Dual blower motors
  3. Larger supply lines
  4. Duplex strainers
- 1-5. What number of basic cooling systems make up a typical liquid cooling system?
1. One
  2. Two
  3. Three
  4. Four
- 1-6. The secondary cooling system transfers the heat load from the electronic equipment to the primary system.
1. True
  2. False
- 1-7. The Navy uses what number of basic configurations of liquid cooling systems?
1. One
  2. Two
  3. Three
  4. Four
- 1-8. Which of the following water resources is/are used for primary cooling?
1. Seawater only
  2. Chilled water only
  3. Seawater and chilled water
  4. Potable water and seawater
- 1-9. The cooling water for the primary cooling system is either seawater or chilled water. The seawater is from the sea and the chilled water is from what source?
1. The liquid cooling system
  2. The ship's air conditioning plant
  3. The ship's firemain system
  4. The reefer deck supply system
- 1-10. When temperature range is considered to be critical, what type of cooling system would most likely satisfy this need?
1. Type I
  2. Type II
  3. Type III
  4. Type IV
- 1-11. What type of liquid cooling system can satisfactorily be operated when seawater temperatures reach 95°F?
1. Type I
  2. Type II
  3. Type III
  4. Type IV
- 1-12. In a primary cooling system, flow regulator may be known by what other term?
1. Expansion tank
  2. Demineralizer
  3. Gate valve
  4. Orifice plate

- 1-13. Open looped seawater systems are also called one-pass because the seawater flows through the system only once.
1. True
  2. False
- 1-14. Secondary cooling systems are which of the following types?
1. Open-loop only
  2. Closed-loop only
  3. Both 1 and 2 above
  4. One-pass
- 1-15. Type I cooling systems employ what type of configuration?
1. Two SW/DW heat exchangers of the same design
  2. Two CW/DW heat exchangers of the same design
  3. One CW/DW heat exchanger and one standby CW/DW heat exchanger
  4. One SW/DW heat exchanger and one standby CW/DW heat exchanger
- 1-16. An expansion tank is installed in what system to compensate for changes in coolant volume?
1. The seawater
  2. The potable water
  3. The distilled water
  4. The chilled water
- 1-17. What term best describes a expansion tank that is located above the highest point in the secondary system and vented to the atmosphere?
1. Pressure tank
  2. Compression tank
  3. Freefall tank
  4. Gravity tank
- 1-18. What term best describes an expansion tank that requires an air charge on the tank and is located below the highest point in the secondary cooling system?
1. Pressure tank
  2. Compression tank
  3. Freefall tank
  4. Gravity tank
- 1-19. What definition best describes the word submicron?
1. Less than one millionth of a meter
  2. Equal to one millionth of a meter
  3. Greater than one millionth of a meter
  4. Equal to one meter
- 1-20. The Type II cooling system employs what configuration?
1. Two SW/DW heat exchangers of the same design
  2. Two CW/DW heat exchangers of the same design
  3. One CW/DW heat exchanger and one standby CW/DW heat exchanger
  4. One SW/DW heat exchanger and one standby CW/DW heat exchanger
- 1-21. The Type III cooling system employs what configuration?
1. Two SW/DW heat exchangers of the same design
  2. Two CW/DW heat exchangers of the same design
  3. One CW/DW heat exchanger and one standby CW/DW heat exchanger
  4. One SW/DW heat exchanger and one standby CW/DW heat exchanger
- 1-22. In a Type III cooling system, the two-way temperature regulating valve is used instead of a three-way valve to regulate the temperature in what system component(s)?
1. The primary loop
  2. The secondary loop
  3. The heat exchangers
  4. The circulating pumps

IN ANSWERING QUESTIONS 1-23 THROUGH 1-29, SELECT FROM THE FOLLOWING LIST THE DEFINITION FOR THE TERM USED AS THE QUESTION.

- A. It is constructed to be shell-type and tube-type in which the secondary coolant flows through the shell, while the primary coolant flows through the tubes.
- B. It maintains a positive pressure on the circulating pump inlet, compensates for changes in the coolant volume and it vents air from the system.
- C. It is used to circulate secondary distilled water.
- D. It regulates the amount of cooling water flowing through or bypassing a heat exchanger to maintain a desired temperature of distilled water going to the electronic equipment.
- E. It is used to provide a constant flow of coolant through the system.
- F. It maintains the secondary cooling system's purity.
- G. It is used in the seawater cooling system to remove debris and sea life, which could clog the pressure and flow control devices.

1-23. Heat exchanger.

- 1. A
- 2. B
- 3. C
- 4. D

1-24. Flow regulators.

- 1. E
- 2. F
- 3. G
- 4. A

1-25. Expansion tank.

- 1. B
- 2. C
- 3. D
- 4. E

1-26. Seawater strainer.

- 1. F
- 2. G
- 3. A
- 4. B

1-27. Temperature regulating valve.

- 1. C
- 2. D
- 3. E
- 4. F

1-28. Circulating pump.

- 1. G
- 2. A
- 3. B
- 4. C

1-29. Demineralize.

- 1. D
- 2. E
- 3. F
- 4. G

1-30. An oxygen analyzer is used to measure the amount of dissolved oxygen in the liquid cooling system. The presence of oxygen causes oxidation within the cooling system.

- 1. True
- 2. False

1-31. When inspecting a telltale drain, you discover that it is leaking. What failure does it indicate?

- 1. The seawater strainer
- 2. The bypass fins
- 3. The tube joint
- 4. The circulating pump

1-32. The overall effectiveness of the heat exchanger is determined by comparing the primary inlet temperature to its outlet pressure. The result of this comparison is best described by what term?

- 1. Temperature variable
- 2. Temperature difference
- 3. Temperature gradient
- 4. Temperature coefficient

1-33. What is the symbol for temperature gradient?

- 1. #T
- 2. %T
- 3. ΔT
- 4. ±T

- 1-34. The device that is inserted in the heat exchanger's water box to concentrate electrolytic action to it vice to the metal of the heat exchanger's tubes is made of what material (s)?
1. Zinc cathode
  2. Zincs only
  3. Zinc anode only
  4. Both 2 and 3 above
- 1-35. Who is the best qualified person on board to determine the overall condition of the cooling system?
1. Engineering officer
  2. Electronics material officer
  3. System's test officer
  4. Ship's maintenance technician
- 1-36. The expansion tank sight glass should normally read in what range?
1. 1/4 to 1/2 full
  2. 1/3 to 2/3 full
  3. 1/2 to 3/4 full
  4. 2/3 to 4/5 full
- 1-37. The low-level alarm switch is usually set at 20 percent of tank capacity. The alarm will initially sound when the distilled water level reaches which of the following levels?
1. 5 percent of full
  2. 10 percent of full
  3. 15 percent of full
  4. 20 percent of full
- 1-38. What term best describes the word makeup water?
1. Distilled water
  2. Seawater
  3. Potable water
  4. Chilled water
- 1-39. When, if ever, may potable water be used in electronic cooling systems?
1. After chloride is added
  2. Only as makeup water
  3. As a replacement for chilled water
  4. NEVER
- 1-40. What is the maximum permissible chloride that may be used in cooling system water?
1. 6.5 ppm
  2. 0.65 ppm
  3. 0.065 ppm
  4. 0.0065 ppm
- 1-41. What is an indication that the duplex strainer is clogged?
1. The pressure reading will be 5 to 10 psi below a clean basket reading
  2. The pressure reading will be 5 to 10 psi above the clean basket reading
  3. The water temperature will be 5 to 10 degree below normal
  4. The water temperature will be 5 to 10 degree above normal
- 1-42. If the pressure drop is less than that of a clean basket reading, the basket may be missing.
1. True
  2. False
- 1-43. The three-way temperature regulating valve is used where seawater is the primary cooling medium, and the two-way valve is used where chilled water is the primary cooling medium.
1. True
  2. False
- 1-44. The basic operation of both the two-way temperature regulating valve is the same as the three-way temperature regulating valve except that the two-way valve has a manual override feature.
1. True
  2. False
- 1-45. Temperature regulating valve corrective maintenance consists only of visual checks for leaks and corrosion.
1. True
  2. False
- 1-46. Which of the following devices is used to regulate flow in a seawater cooling system?
1. The gate valve
  2. The globe valve
  3. The orifice plate
  4. The relief valve
- 1-47. Which of the following flow regulators is used to regulate flow in the chilled water system?
1. The globe valve
  2. The orifice plate
  3. The variable orifice
  4. The equipment-flow regulator

- 1-48. Which of the following devices would be used to protect a cooling system from over pressurization?
1. The variable orifice
  2. The pressure regulator
  3. The equipment-flow regulator
  4. The relief valve
- 1-49. What is the function of a typical low-flow switch?
1. To indicate low coolant flow
  2. To indicate excessive coolant flow
  3. To redirect coolant flow to another load
  4. To control coolant flow through the heat exchangers
- 1-50. In a venturi-type flowmeter, the flow rate is measured by what process?
1. The pressure differential between the two taps
  2. The decreased coolant velocity
  3. The turbulence of the coolant
  4. The diameter of the throat
- 1-51. Which of the following flowmeters allows visual inspection of the coolant for entrained air?
1. The orifice-type
  2. The venturi-type
  3. The purity-type
  4. The rotameter-type
- 1-52. Operating a circulating pump with insufficient coolant flow could cause which of the following malfunctions?
1. The overheating of the pump only
  2. The seizure of the pump only
  3. Both 1 and 2 above
  4. The reduction of outlet pressure
- 1-53. What percent of the coolant flows through the demineralizer in one hour?
1. 100%
  2. 50%
  3. 20%
  4. 5%
- 1-54. Which of the following demineralizer components is used to remove small particles from the coolant?
1. The mixed-bed cartridge
  2. The organic cartridge
  3. The oxygen removal cartridge
  4. The submicron filter
- 1-55. Which of the following contaminations is least likely to occur in a distilled water and ethylene glycol coolant system?
1. Dissolved oxygen
  2. Chlorine
  3. Oxidized metal
  4. Bacterial
- 1-56. Demineralize performance and coolant purity is monitored by measuring what property of the coolant?
1. Temperature compensation
  2. Conductivity
  3. Pressure differential
  4. Resistivity
- 1-57. Scheduled maintenance of a demineralizer consists primarily of performing what preventive action?
1. Adjusting the coolant flow through the system
  2. Replacing the purity monitors
  3. Replacing the filters and cartridges
  4. Calibrating the purity monitors
- 1-58. Which of the following contaminates could be considered a source of contamination for an oxygen analyzer sensor?
1. Electrolyte
  2. Oil from your fingers
  3. Direct sunlight
  4. Fluorescent lighting
- 1-59. What position on an alarm switchboard is used for alarm acknowledgement?
1. Normal
  2. Standby
  3. cutout
  4. Test
- 1-60. What position on an alarm switchboard is used to simulate an alarm position?
1. Normal
  2. Standby
  3. Cutout
  4. Test

- 1-61. What is the first step in isolating the extent of waveguide flooding?
1. Secure the cooling system
  2. Estimate the amount of coolant lost
  3. Secure the dry air system
  4. Open the lowest point in the waveguide

---

Learning Objective: Describe the dry air system components and their operation.

---

- 1-62. Dew point is best defined by which of the following statements?
1. Temperature at which water vapor begins to deposit as a liquid
  2. Temperature at which water vapor starts to condensate
  3. Temperature of precipitation
  4. Temperature of the water particles in the air
- 1-63. Compressing air has what effect, if any, on relative humidity?
1. It will increase
  2. It will decrease
  3. It will vary inversely with the pressure
  4. None

IN ANSWERING QUESTIONS 1-64 THROUGH 1-67, SELECT FROM THE LIST BELOW THE DEFINITION FOR THE TERM INDICATED IN THE QUESTION.

- A. Uses a combination of refrigeration and desiccant to dry the air
- B. Compresses the air
- C. Uses adsorption ONLY to dry the air
- D. Uses freezing ONLY to dry the air

1-64. Type I dehydrator.

1. A
2. B
3. C
4. D

1-65. Type II dehydrator.

1. A
2. B
3. C
4. D

1-66. Type III dehydrator.

1. A
2. B
3. C
4. D

1-67. Air compressor.

1. A
2. B
3. C
4. D

1-68. What is the normal mode of operation of an equipment air dryer?

1. Start-up
2. Fluid separation
3. Automatic
4. By-pass

1-69. Oil vapor is removed from the compressed air by which of the following methods?

1. By absorption
2. By adsorption
3. By ionization
4. By fluid separation

IN ANSWERING QUESTIONS 1-70 THROUGH 1-75, SELECT FROM THE AIR DRYER COMPONENTS LISTED BELOW AND MATCH THEIR COMPONENTS FUNCTION USED IN THE QUESTION.

- A. Fluid separator
- B. Telltale oil filter
- C. Pressure regulator
- D. Dehydrator

1-70. It contains a desiccant chambers to dry the air.

1. A
2. B
3. C
4. D

1-71. It controls inlet air to the dehydrator.

1. A
2. B
3. C
4. D

1-72. It uses centrifugal force to extract droplets of liquid.

1. A
2. B
3. C
4. D

1-73. It uses absorption to remove oil vapor.

1. A
2. B
3. C
4. D

1-74. It provides the input to the pressure regulator.

1. A
2. B
3. C
4. D

1-75. It discharges oil and water through a muffler.

1. A
2. B
3. C
4. D

## ASSIGNMENT 2

Textbook Assignment: "AC Power Distribution System," chapter 3, pages 3-1 through 3-18; "Ship's Input Systems," chapter 4, pages 4-1 through 4-9; "Information Transfer Systems," chapter 5, pages 5-1 through 5-16.

---

---

Learning Objective: Identify the fundamentals of the ship's service power distribution systems.

---

- 2-1. Which of the following systems comprises the shipboard power distribution system?
1. The casualty power system only
  2. The emergency power system only
  3. The ship's service system only
  4. All of the above
- 2-2. What is the function of the switchboard bus ties?
1. To permit switchboards to be cross connected and to allow paralleling of generators
  2. To allow power distribution directly from the generator to the load
  3. To allow the generators to operate in series
  4. To feed power to the dc generator
- 2-3. On small ships, centrally locating switchboards (with respect to the load) and feeding them directly from the generators have which of the following advantages?
1. It simplifies the installation
  2. It reduces size and weight requirements
  3. It reduces equipment requirements
  4. Each of the above
- 2-4. Circuit information plates are located on which of the following locations?
1. The bulkhead near the fuse boxes
  2. The distribution panels and bus transfer equipment
  3. The electric cables
  4. All equipment controllers
- 2-5. Why is the phase sequence important to the power distribution system aboard ship?
1. An improper phase will cause voltage fluctuations
  2. The phase sequence determines the amount of current available
  3. The phase sequence determines the direction of rotation of three-phase motors
  4. Distribution panel bus bars are label alphabetically from top to bottom
- 2-6. What service is provided by bus transfer equipment?
1. It provides two sources of power to vital ship's equipment
  2. It provides short-circuit protection to the ship's service generators
  3. It provides overload protection to ship's circuit breakers
  4. It provides protection from paralleling two switchboards that are out of phase
- 2-7. If NORMAL power were to fail supplying the HF transmitter, ALTERNATE power would be restored by the use of which of the following components?
1. Manual bus transfer (MBT) only
  2. Automatic bus transfer (ABT) only
  3. Either 1 or 2 above
  4. Communications switchboard
- 2-8. Aboard ships, switchgear groups are physically separated as much as practical to achieve what objective?
1. Easy access for maintenance
  2. Reduce accidental loss of power
  3. Afford greater protection from battle damage
  4. Prevent unnecessary cost and weight during ship's construction



- 2-9. Which of the following actions is NOT a function provided by switchboards aboard ships?
1. Automatic shifting of power to alternate sources if normal power is lost
  2. Distribution of three-phase, 450 volt power
  3. Circuit protection
  4. Control, monitoring, protection of the ship's service generators
- 2-10. What is the purpose of disconnect links?
1. They provide a convenient means of load testing
  2. They provide isolation from one switchboard while repairs are being conducted on another
  3. They provide a means of securing switchboard power in case of fire
  4. They provide over current protection to the main bus
- 2-11. The output of all ac generators is developed in what part of the generator?
1. The field windings
  2. The stator windings
  3. The rotor windings
  4. The armature windings
- 2-12. What are the two major assemblies of an ac generator?
1. Stator and rotor
  2. Stator and armature
  3. Armature and rotor
  4. Armature and fields
- 2-13. Three-phase generators have single-phase windings located what number of degrees out of phase from the other windings?
1. 90° out of phase with the other two windings
  2. 120° out of phase with the other two windings
  3. 180° out of phase with the other two windings
  4. 360° out of phase with the other two windings
- 2-14. The three-phase, four-wire, STAR connected power distribution system is also know by what other term?
1. Delta connected
  2. Ana connected
  3. Wye connected
  4. Jal connected
- 2-15. In a transformer, electrical energy is transferred from one circuit to another through which of the following actions?
1. Hysteresis coupling
  2. Electrostatic radiation
  3. Electromagnetic induction
  4. Inductive reactance
- 2-16. Energy in a transformer is always transferred without a change in frequency, but you can expect a change in which of the following attributes?
1. Amplitude and time
  2. Inductance and current
  3. Current and voltage
  4. Voltage and inductance
- 2-17. Which transformer winding is designated as the primary winding?
1. The one that receives energy from an ac source
  2. The one with the highest voltage
  3. The one with the lowest voltage
  4. The one that delivers energy to the load
- 2-18. What are the two principle types of transformers?
1. Core and shell
  2. primary and secondary
  3. Single-phase and polyphase
  4. Ac and dc
- 2-19. Most power supply transformers are designed to operate at frequencies of
1. 50 to 60 Hz
  2. 60 to 120 Hz
  3. 120 to 220 Hz
  4. 220 to 400 Hz
- 2-20. Transformers of higher frequencies are of smaller design and permit savings of weight and use of associated equipments.
1. True
  2. False
- 2-21. The use of varnish to insulate adjacent laminations in a transformer core helps minimize which of the following factors?
1. Heat dissipation to the enclosure
  2. Hysteresis losses
  3. Magnetization of the secondary winding
  4. Magnetization of the primary winding

- 2-22. In transformer lead markings, the high voltage leads are marked H1, H2, H3, etc. The letter signifies high voltage, what does the number indicate?
1. Numerical position from the transformer's core
  2. Shows total number of high voltage leads
  3. The higher the number, the higher the voltage
  4. Used for identification and tracing purposes
- 2-23. Transformer secondary lead markings are identified by which of the following letters?
1. R
  2. H
  3. X
  4. S
- 2-24. Which of the following types of equipment are used to supply 400 Hertz power to a transformer?
1. Motor-generator units
  2. Static converters
  3. Both 1 and 2 above
  4. Steam turbines
- 2-25. What is the primary purpose of the casualty power system?
1. To make temporary connections to vital circuits
  2. To make permanent connections to vital equipment
  3. To make permanent connections to vital circuits
  4. To make temporary connections to ac generators
- 2-26. Casualty power bulkhead terminals are permanently installed on opposite sides of bulkheads for what reason?
1. To provide casualty power to selected equipment
  2. To transfer power through decks without loss of watertight integrity
  3. To transfer power through decks 180° out of phase with other bulkhead terminals
  4. To transfer power through decks 90° out of phase with other bulkhead terminals
- 2-27. When a generator is used exclusively for casualty power, you must perform which of the following actions?
1. Open the generator circuit breaker
  2. Open the generator disconnect links
  3. Remove all normal circuits from the switchboard that the generator is feeding
  4. Transfer all bus transfer switches to emergency power
- 2-28. A portable cable used to rig ac casualty power can carry (a) what maximum amount of current and (b) for what maximum number of hours?
1. (a) 93 A (b) 4 hours
  2. (a) 93 A (b) 40 hours
  3. (a) 200 A (b) 40 hours
  4. (a) 200 A (b) 4 hours
- 2-29. Shore power connections aboard ship may be used to supply power to another ship alongside.
1. True
  2. False
- 2-30. When testing shore power cables, you should use which of following grounds as a shore ground resistance?
1. The ship's hull
  2. A 16 AWG or larger wire with one side cropped over the side of the ship
  3. The enclosure that houses the shore-power terminals or receptacles
  4. Phase A of the shore-power cable
- 2-31. What is the key component of the phase-sequence indicator?
1. The three-phase induction motor
  2. The saturable reactor
  3. The ion drive clutch assembly
  4. The digital display
- 
- Learning Objective: Describe and identify components of various gyrocompass systems.
- 
- 2-32. The gyrocompass system provides a means of determining ownship's
1. heading, roll, and pitch
  2. speed, distance, and bearing
  3. heading, speed, and distance
  4. speed, roll, and pitch

- 2-33. Gyrocompass systems are identified by the mark, (Mk), and modification (Mod) system. The MK number designates a
1. major development of a compass
  2. major modification of a compass
  3. a change to a major development of a compass
  4. a major modification to a change of a compass
- 2-34. The Mk 19 gyrocompass consists of four major components: the control cabinet, the failure annunciator, the master compass and the
1. power supply
  2. slave compass
  3. indicator
  4. power converter
- 2-35. Thirty-six speed indicators are used instead of single-speed indicators when least precise readings are required.
1. True
  2. False
- 2-36. The Mk 23 gyrocompass consists of what major units?
1. The master unit and control cabinet only
  2. The compass failure annunciator, alarm bell only
  3. The alarm control and speed unit only
  4. All of the above
- 2-37. What are the three major components that make up the Mk 27 gyrocompass?
1. The master unit, control cabinet, and power converter
  2. The master unit, switching unit, and power converter
  3. The master unit, slave unit, and control cabinet
  4. The master unit, speed compensator, and switching unit
- 2-38. The AN/WSN-2 stabilized gyrocompass consists of five major components: the inertial measuring unit, the control power supply, the amplifier synchro signal, the battery set, and what other unit?
1. The master unit
  2. The slave unit
  3. The speed compensating unit
  4. The control indicating unit
- 2-39. Generally each radar system will have its own synchro signal amplifier.
1. True
  2. False
- 2-40. Synchro signal converters can convert 60 Hz to 400 Hz and 400 Hz to 60 Hz. What other conversions can it make?
1. Relative bearing to true bearing
  2. Synchro speed
  3. Synchro frequency
  4. All of the above
- 2-41. What number of the AN/WSN-5 inertial navigation sets are generally installed on board?
1. Four
  2. Three
  3. Two
  4. One
- 2-42. The underwater log system measures and indicates what attributes?
1. Speed of the ship in knots and distance traveled through the water in statute miles
  2. Speed of the ship in miles per hour and distance traveled through the water in knots
  3. Speed of the ship in knots and distance traveled through the water in nautical miles
  4. Speed of the ship in miles per hour and distance traveled through the water in miles per hour
- 2-43. Which of the following equipments are types of underwater log systems?
1. Electro-static and Doppler
  2. Electro-static and phased-array
  3. Electromagnetic and phased-array
  4. Electromagnetic and Doppler
- 2-44. The sea valve, provides support for the rodmeter, and also provides a seal to the hull when the rodmeter is removed. What other function, if any, does the sea valve provide?
1. It provides the data for its transmission to the underwater log system
  2. It monitors the flow of data in the underwater log system
  3. It provides conversion of input data to the underwater log system
  4. None

- 2-45. What is another term for the name rodmeeter?
1. Foot
  2. Boot
  3. Knife
  4. Sword
- 2-46. What are two types of digital switchboards?
1. Automatically controlled and manually controlled
  2. Analog controlled and digitally controlled
  3. Manually controlled and remotely controlled
  4. Automatically controlled and remotely controlled
- 2-47. On digital switchboards, what is the minimum number of manual switches required for each I/O device computer channel?
1. One
  2. Two
  3. Three
  4. Four
- 2-48. Control signals used to select the desired switch configuration are generated by which of the following devices?
1. DFCS only
  2. CSCP only
  3. Both 1 and 2 above
  4. The DSCS only
- 2-49. Each DFCS section contains what maximum amount of switch panels?
1. 12
  2. 18
  3. 24
  4. 32
- 2-50. The linear movement switches are usually positioned by control signals from what source?
1. DSCS
  2. DFCS
  3. CSMP
  4. CSCP
- 2-51. The power distribution panel assembly contains six indicators mounted on the front of the panel to indicate the presence of power when applied to the panel.
1. True
  2. False
- 2-52. Linear switches perform either three-position or five-position switching functions. The three-position switches are used for
1. NORMAL/ALTERNATE switching with an OFF position
  2. NORMAL/ALTERNATE switching with an ON position
  3. REMOTE/MANUAL with an OFF position
  4. REMOTE/MANUAL with an ON position
- 2-53. When a linear switch is in the remote position, what piece of equipment has control of the switch position?
1. DFCS
  2. CSCP
  3. The computer
  4. Remote equipment
- 2-54. The switch control and potentiometer transformer ACO assembly is used to provide voltages for bench testing which of the following DFCS panels?
1. Relay tester assemblies
  2. Power distribution panels
  3. Linear movement switches
  4. All of the above
- 2-55. Four colors are used for PBI indicators on the CSCP: white, red, green and yellow. What indication is provided by yellow?
1. Switch is the ON position
  2. Switch is in the OFF position
  3. Switch is in the ALTERNATE position
  4. A logic error exists in the PBI circuitry
- 2-56. The HOLD PBIs are used to indicate what function?
1. Control transfer initiated
  2. Control transfer complete
  3. Control transfer refusal
  4. Each of the above
- 2-57. Ship's wire marking codes provide what information?
1. Circuit designation, function number and assigned wire number
  2. Function number, circuit designation and assigned wire number
  3. Assigned wire number, circuit designation and function number
  4. Function number, assigned wire number and circuit designation

- 2-58. A ship's wire has a plastic sleeve with the following markings on it, 12 PD 1952. What does the 1952 indicate?
1. The year the cable was manufactured
  2. The circuit designation
  3. The function number
  4. Assigned wire number
- 2-59. What two types of connectors does the CSCP use?
1. 10-pin and 85-pin
  2. P and J
  3. Type A and Type B
  4. Amphenol and Portsmouth
- 2-60. Reference designations of JA, JB, JN, and JP are used with what type connectors?
1. P-connectors
  2. Type B connectors
  3. 10-pin connectors
  4. Amphenol connectors
- 2-61. Each analog switchboard section contains what maximum number of panels?
1. 6
  2. 12
  3. 24
  4. 36
- IN ANSWERING QUESTIONS 2-62 THROUGH 2-66, SELECT FROM THE FOLLOWING LIST THE ANALOG SWITCHBOARD PANEL THAT PERFORMS THE FUNCTION LISTED IN EACH QUESTION.
- A. Indicator panel assembly
  - B. Fuse panel assembly
  - C. Meter panel assembly
  - D. Flasher panel assembly
  - E. Snap switch panel assembly
- 2-62. Monitors ac and dc power buses.
1. A
  2. B
  3. C
  4. D
- 2-63. Contains overflow fuses for associated switch panels.
1. A
  2. B
  3. C
  4. D
- 2-64. Provides a visual indication of the active power being supplied to the switchboard.
1. A
  2. B
  3. C
  4. D
- 2-65. Indicates a warning or emergency condition.
1. B
  2. C
  3. D
  4. E
- 2-66. Provides manual control of switchboard power buses.
1. B
  2. C
  3. D
  4. E
- 2-67. Manually operated JR switch panel assemblies and remotely operated JR switch panel assemblies provide the same function with the exception that one can be operated remotely.
1. True
  2. False
- 2-68. When a control signal is fed back to the KCMX as a status signal input by the switchboard for test purposes, the switchboard is in which of the following configurations?
1. NORMAL
  2. OFF
  3. REMOTE
  4. EAT
- 2-69. The SB-4229/SP switchboard replaces which of the following switchboards?
1. SB-440
  2. SB-1109
  3. SB-1505
  4. Each of the above
- 2-70. The SB-4229/SP can accept (a) how many radar set inputs and (b) distribute them to what number of radar indicators?
1. (a) Five (b) four
  2. (a) Five (b) six
  3. (a) Six (b) nine
  4. (a) Nine (b) sixteen

- 2-71. The signal data converter (SDV) conditions and multiplexes its various data inputs into a single analog data stream.
1. True
  2. False
- 2-72. All replaceable modules, assemblies and printed circuit boards with a high-cost value are designed and constructed to be repairable to component level with the exception of which of the following components?
1. High-voltage power supplies
  2. CRT back plane wiring harness
  3. Both 1 and 2 above
  4. Back plane wiring harness
- 2-73. On the SB-988/SRT Transmitter Transfer Switchboard, each knob has 8 positions. What position removes the remote from the system?
1. 8
  2. 7
  3. 6
  4. 5
- 2-74. The SB-973/SRT receiver switchboard allows the audio outputs of the receivers to be
1. heterodyned and transferred to remote stations
  2. multiplexed and transferred to remote stations
  3. transferred to remote stations
  4. amplified and transferred to remote stations
- 2-75. The SB-973/SRT switchboard contains 10 switches that have what number of positions?
1. Eight
  2. Seven
  3. Six
  4. Five