

OWNERS MANUAL

Block Buster Compact Masonry Saw



MODELS
BBC157 BBC207
BBC307 BBC547
BBC507

Form BBC157-207-307-547-507 Manual Rev 9-2010



WARRANTY

Norton warrants all products manufactured by it against defects in workmanship or materials for a period of one (1) year from the date of shipment to the customer.

The responsibility of Norton under this warranty is limited to replacement or repair of defective parts at Saint-Gobain Abrasives, Inc. Stephenville, Texas factory, or at a point designated by it, of such part as shall appear to us upon inspection at such point, to have been defective in material or workmanship, with expense for transportation borne by the customer.

In no event shall Norton be liable for consequential or incidental damages arising out of the failure of any product to operate properly.

Integral units such as **gasoline engines, electric motors, batteries, tires, transmissions, etc.**, are excluded from this warranty and are subject to the prime manufacturer's warranty.

This warranty is in lieu of all other warranties, expressed or implied, and all such other warranties are hereby disclaimed.

Important: Before placing equipment in operation, record the following information.

MODEL: _____ **SERIAL NO.** _____

PURCHASE FROM: _____

ADDRESS: _____

CITY _____ **STATE** _____ **ZIP** _____

TELEPHONE NO. _____

***Before using this equipment, make sure that person using it
Read and understand the instructions in this owner's manual.***

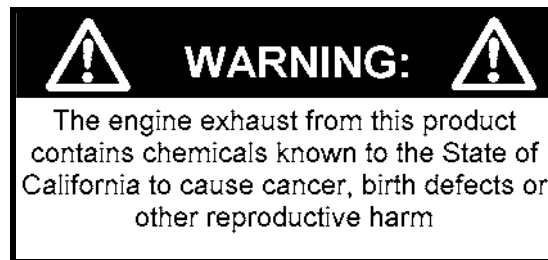

BBC 157/207/307/547/507 OWNER'S MANUAL

CONTENTS	PAGE
I. Preparation	
A. Safety Precautions	4-6
B. Assembly	7-12
C. Specifications	13
D. Electrical Connections	14
E. Wiring Diagram	15-16
F. Gasoline Engine	17
II. Operation	
A. How to mount Blade	18
B. How To Use "Step Cutting" with abrasive blades	19
C. How To Use "Jam Cutting" And "Step Cutting" With Diamond Blades.	20
D. Dry Cutting	21
E. Wet Cutting	21
III. Maintenance	
A. V-Belts	22
B. Electric Motor	23
Electric Motor Warranty/Service	23
C. Gasoline Engine	23
Gasoline Engine Warranty/Service	23
D. Blade Shaft Bearings	23-24
E. Water Pump	24
IV. Parts List Section	
A. Ordering Information	25
B. Parts List	26-34
C. Baldor Service Policy	35
D. Honda Service Policy	36



Read Owners Manual Before Use

Safety Alert Symbol: Information Following This Symbol Is Very Important.

Use Only Norton Clipper Diamond Blades

I. PREPARATION

A. Safety Precautions

Important! The following safety precautions must always be observed.

Hazard Symbols



Fuel (gasoline) is extremely flammable and its vapors can explode if ignited. Store gasoline only in approved containers, in well-ventilated, unoccupied approved areas, and away from sparks or flames. Do not fill the fuel tank while the engine is hot or running. Do not start the engine near spilled fuel. Never use the fuel as a cleaning agent



Engine components can get extremely hot from operation. To prevent burns, do not touch the engine or related parts while the engine is running or immediately after it is turned off. Never operate the engine with any heat shields or guards removed.



Keep all guards in place when operating any piece of equipment



Keep hands, feet, hair, and clothing away from all rotating parts



Lethal Exhaust Gas use only in well ventilated areas. Engine exhaust gases contain poisonous carbon monoxide, which is odorless, colorless, and can cause death if inhaled. Avoid inhaling exhaust fumes, and never run the engine in a closed building or confined area



Never tamper with the governor components of settings to increase the maximum speed. Severe personal injury and damage to the engine or equipment can result if operated at speed above maximum. Always obey the maximum speed rating of blade.



DO NOT LIFT THE SAW BY THE HANDLE BARS

WARNING

Dust and Silica Warning

Grinding/cutting/drilling of masonry, concrete, metal and other materials can generate dust, mists and fumes containing chemicals known to cause serious or fatal injury or illness, such as respiratory disease, cancer, birth defects or other reproductive harm. If you are unfamiliar with the risks associated with the particular process and/or material being cut or the composition of the tool being used, review the material safety data sheet and/or consult your employer, the material manufacturer/supplier, governmental agencies such as OSHA and NIOSH and other sources on hazardous materials and make certain to comply with all product warnings and instructions for the safe and effective use of the material being cut. California and some other authorities, for instance, have published lists of substances known to cause cancer, reproductive toxicity, or other harmful effects.

Control dust, mist and fumes at the source where possible. In this regard use good work practices and follow the recommendations of the manufacturer/supplier, OSHA/NIOSH, and occupational and trade associations. Water should be used for dust suppression when wet cutting is feasible. When the hazards from inhalation of dust, mists and fumes cannot be eliminated through engineering controls such as either vacuum and/or water mist, the operator and any bystanders should always wear a respirator approved by NIOSH/MSHA for the material being cut.

Use Approved:



Eye Protection



Hearing Protection



Respiratory Protection



Head Protection

1. Before mounting any blade on the saw, the blade should be inspected for any damage which might have occurred during shipment, handling or previous use.
2. The blade collars and arbors should be cleaned and examined for damage before mounting the blade.
3. The blade must be properly fitted over the arbor with the drive pin on the outside collar projecting through the drive pinhole on the blade and inside collar.
4. The blade shaft nut, which is a left-hand thread nut, must be tightened securely against the outside blade shaft collar.
5. The blade must be operated within the specified maximum operating speed listed on the blade.
6. Turn water control valve to full to provide adequate coolant (4 to 6 gallons per minute) for diamond blades and wet cutting abrasive blades. Insufficient coolant could result in severe blade breakage or diamond segment separation.
7. The blade guard must be in place with the nose guard down and locked when the saw is running.
8. The operator should wear safety glasses and any other appropriate safety equipment.
9. When starting the saw, the operator should stand away and to the side of the blade.
10. If for any reason the saw should stall in the cut, raise the blade out of the cut. Check the outside blade shaft collar and nut for tightness. Inspect the blade for damage before restarting the saw. Use caution when resuming a cut. Be certain that the blade is in alignment with the previous cut.
11. During cutting operations, do not exert excess side pressure on the handles as a method of steering. Do not force the blade into the cut by lowering the blade too fast or by pushing the saw too fast.



You Are Responsible For Your Safety!!!

I. PREPARATION

B. Assembly

The compact Masonry saws are shipped completely assembled and ready for use except for diamond blade, gasoline, oil, and Head Locking Bar. Inspect the saw for shipping damage. If any damage is found, contact the shipper immediately and file a freight claim.

The Norton Company is not responsible for any freight-related damages.

Remove the saw from the pallet.

Items Included with the saw:

Item	Part Number	QTY
Head Locking Handle	82738	1
Depth Limit Assembly		1
Leg Kit (Contains one (1) Leg and Cap) Sold Individually	75817	4
Conveyor Cart Assembly	83754	1
Guide-A-Cut Assembly	83892	
Water Curtain Assembly	75128	1
Wrench 19 mm	70807	1
Wrench 22mm	72143	1
Water Pump Assembly	72305	1
14" Genuine Norton Diamond Blade for Brick And Block	7499	1

Head Locking Handle:

Remove the Head Locking Screw from the machine (see *Figure: Head Locking Screw Removal*). Replace the Head Locking Screw with the Head Locking Handle located in the plastic bag of accessories (see *Figure: Head Locking Handle Installation*). Read and understand the remaining sections of this Owners Manual.

The Head Locking Handle is used to lock the cutting head at a set position or depth of cut. The Head Locking Screw is only used to hold the Cutting Head of the machine in place at the Norton Company Factory.



Do not install the blade until it is time to use the saw!



ANSI regulations prohibit the transportation of any concrete saw with the blade installed!



Figure 1: Head Locking Screw Removal



Figure 2: Head Locking Handle Installation

Depth Limiting Bolt:

Remove the 12mm Carriage Bolt, 12mm Large Flat Washer (DIN9021), 12mm Flat Washer, 12mm Lock Washer, and 12mm Nut from the plastic Bag. Place the 12mm Large Washer over the 12mm Carriage Bolt. Slide the 12mm Carriage thru the Head Locking handle Slot either above the Head Locking Handle (to limit the depth of cut) or below the Head Locking Handle (to limit the tilt angle of the Cutting Head) and attach the 12mm Flat Washer, 12mm Lock Washer, and 12mm Nut as show in **Figure 3: Depth Limiting Bolt Assembly**.

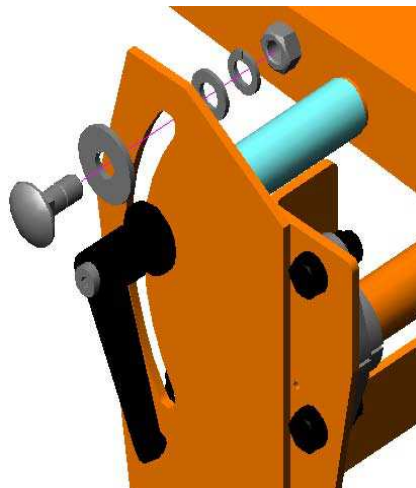

Figure 3: Depth Limiting Bolt Assembly

Leg Assembly:

Remove the four (4) Legs from the Saw Water Pan, and the four (4) Plastic Handle Knobs and four (4) Square Nuts from the plastic bag. Place one (1) Square Nut into each of the Nut Retaining Brackets located on each of the Leg Holders. Attach one (1) Plastic Knob to each of the Square Nuts as shown in **Figure 4: Plastic Knob Attachment**. NOTE: Do not tighten Plastic Knobs at this time. Place one (1) Leg into each of the Leg Holders and tighten the Plastic Knobs see **Figure 5: Leg Attachment**.

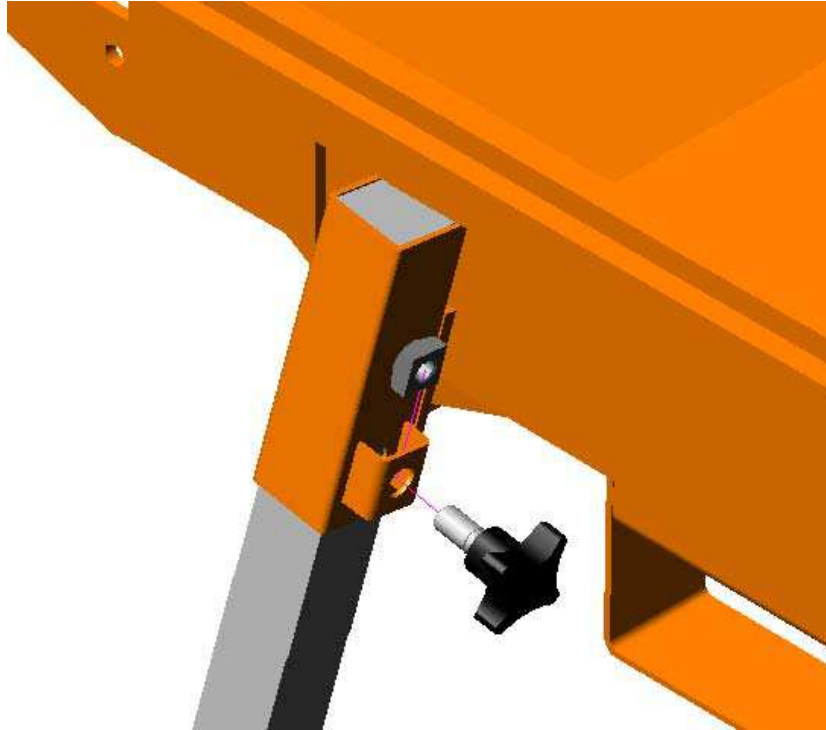

Figure 4: Plastic Knob Attachment

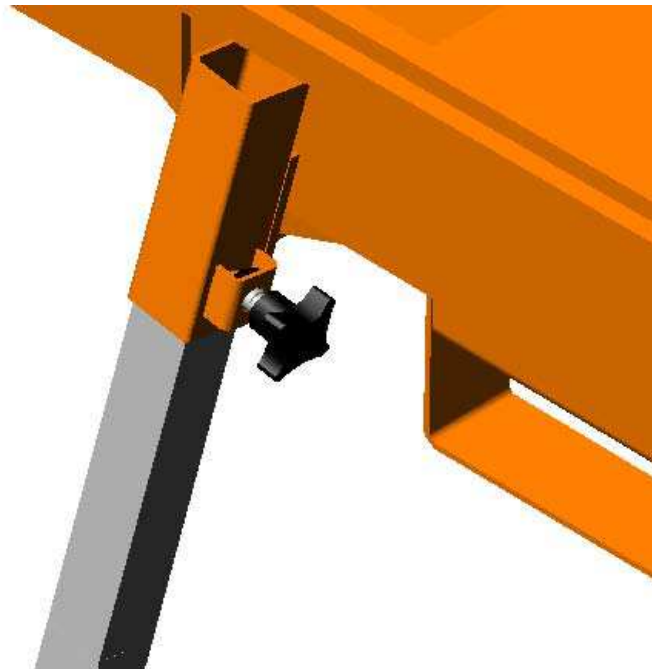

Figure 5: Leg Attachment

Conveyor Cart Assembly:

Remove the Conveyor Cart and Back Stop from the Saws Water Pan, and the Wing Nuts, Carriage Bolts, Washers, and Cart Stop from the plastic bag. Slide one (1) Carriage Bolt thru each of the three (3) Square Holes located on the front of the Conveyor Cart. Slide the Back Stop Over each of the Carriage Bolts. Slide the Stop Assembly over the Carriage Bolt Located on the Left front of the Conveyor Cart NOTE: The Rubber Stop will faces away from the Conveyor Cart. Attach one (1) Washer and one (1) Wing Nut to each Carriage Bolt and Tighten. **See Figure 6: Back Stop Assembly.** Place the Conveyor Cart on the Machine **see Figure 7: Conveyor Cart Installation.**

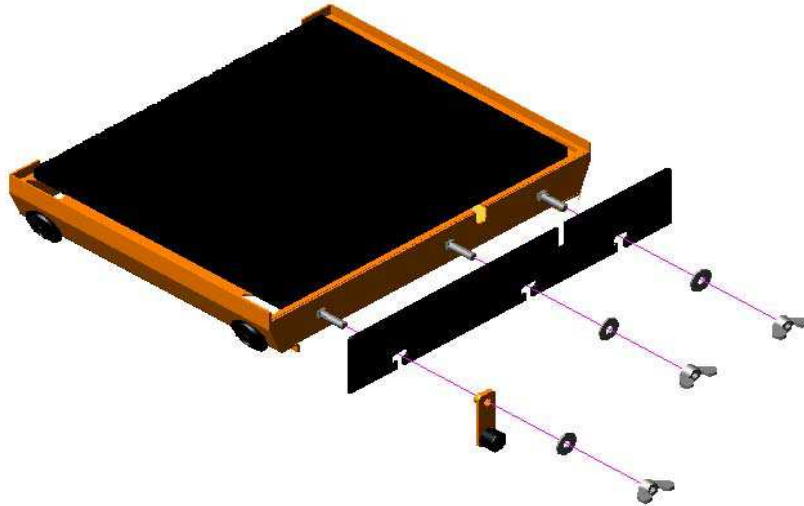

Figure 6: Back Stop Assembly

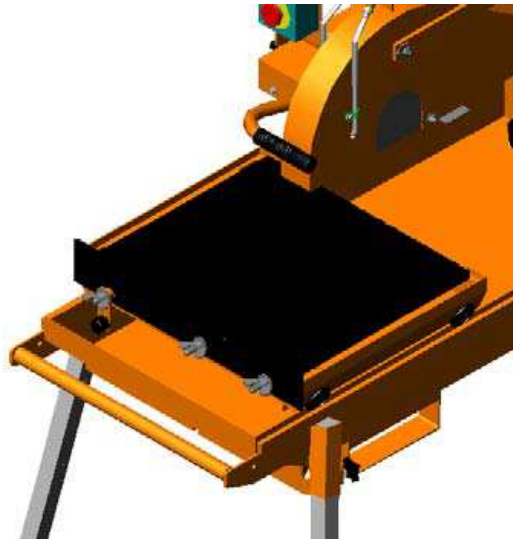

Figure 7: Conveyor Cart Installation

Guide-A-Cut Assembly:

Attach the Guide-A-Cut to the Conveyor Cart by adjusting the Wing Bolt until the Guide-A-Cut can slide over the Black Stop. The Guide-A-Cut will work as a Rip Guide that is adjustable for 90° and 45° cuts. See **Figure 8: Guide-A-Cut Assembly.**

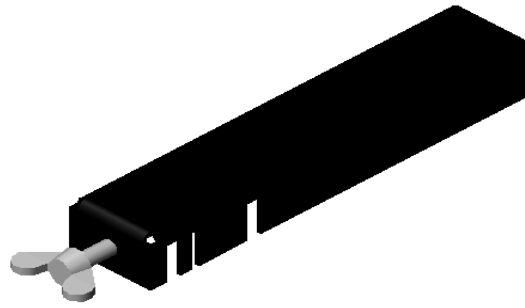

Figure 8: Guide-A-Cut Assembly

Water Curtain Assembly:

Remove the Water Curtain from the Saw Water Pan. Attach the Water Curtain Spring Clips to the Pivoting Bar Located Under the Cutting Head. Note that the rough side of the Water Curtain should face towards the front of the saw. The Water Curtain material is made is designed to be easy to clean. To clean simply rinse the Water Curtain with water until clean. The Water Curtain should be used when wet cutting to reduce the amount of debris thrown from the blade and cutting surface. When dry cutting the Water Curtain can be removed to allow the dust particles to drift away from the Saw Operator. See **Figure 9: Water Curtain Assembly.**

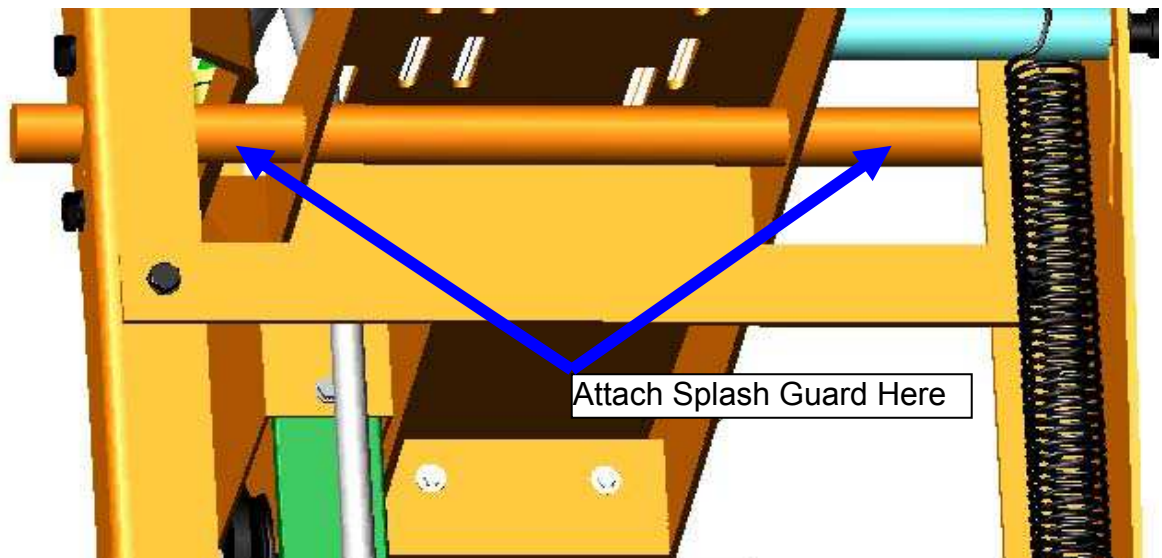

Figure 9: Splash Guard Assembly

Wrenches:

Remove the 19mm and 22mm Wrenches from the plastic bag. Place the Wrenches in the Wrench Holder Slots located in the rear of the machine see **Figure10: Wrench Placement.**

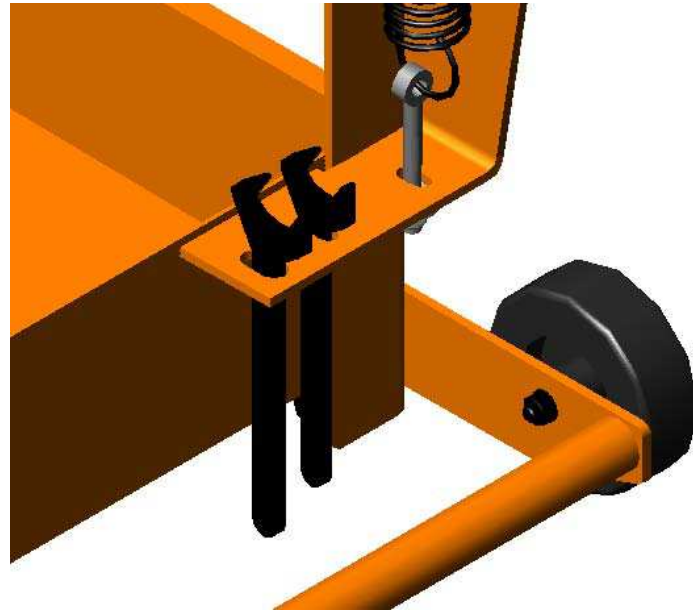

Figure 10: Wrench Placement

Water Pump Assembly:

The Water Pump requires no additional assembly.

I. PREPARATION

C. BBC157/207/547 Series Masonry Saw Specifications

Dimensions/Weight	
Length (Working)	60" (1524mm)
Width	24" (965mm)
Height (Electric)	34" (864mm)
Height (Gas)	38" (965mm)
Weight (Electric) Uncrated	250lbs (kg)
Weight (Gas) Uncrated	275lbs (kg)
Electric Motor	
Motor Mfg.	Baldor
Motor Type	TEFC, Thermal Protection
Motor Voltages	115-230 (Switch able) 60 Hz single Phase
Motor RPM	3450
BBC157 Horse Power	1-1/2 HP
BBC157 Amp Draw	13.4 Amp @ 115v, 6.7 Amp @ 230v
BBC207 Horse Power	2 HP
BBC207 Run Amp	16.8 Amp @115v, 8.4 Amp @ 230v
BBC307 Horse Power	3 HP
BBC307 Run Amp	14.3-14.5 Amp @ 230v
Engine	
Engine Mfg.	Honda
Model	GX160
Spec No.	GX160K1QXC9
Engine Type	Single Cylinder 4 Cycle
Horse Power	5.5 hp (4.0 kW) @ 3,600 rpm
Max Torque	8 ft-lbs (11 Nm, 1.1 kg-m) @ 2,500 rpm
Cooling System	Forced Air
Oil Capacity	0.6 liter (0.63 US qt)
Fuel Capacity	3.6 liter (0.95 US gal)
Fuel Type	Unleaded Gasoline (86 pump octane)
Fuel Consumption	310 g/kWh (0.51 lb/Hp hr)
Low Oil Sensor	Yes
Air Filtration	Four Stage Cyclone
Characteristics	
Max Blade	Ø14" (356 mm) BBC157, BBC207, and BBC547 Ø20" (203 mm) BBC307 & BBC507
Depth of Cut 20" (508 mm)	8" (203 mm)
14" (356 mm)	5" (127 mm)
12" (305 mm)	4" (102 mm)
Arbor Bore	1" (25.4 mm)
Blade Shaft Locking Device	Machined Into Flats Of Tight Collar
Blade Shaft Speed	2900 rpm
Depth Control	Hand Feed With Return Spring
Depth Lock	Standard
Number Of V-Belts	1
Blade Guard Type	All Steel Construction
Stay Level Blade Guard	Yes
Fork Lift Brackets	Built In
Rolling Wheels	Standard
Water Pump	Standard, Mechanically Belt Driven
Sound pressure ¹ (Gasoline Engine)	88 db (A)
Sound power ¹ (Gasoline Engine)	105 db (A)

1) The sound measures have been made following pr EN 12638, Annex A; 2) " Floor sawing, grooving and milling machines – Safety "

I. PREPARATION

D. Electrical Connections



Important-Before connecting the motor leads to the power supply be sure that the voltage, cycles and phase shown on the nameplate of the motor correspond to the available power supply.

Voltage Selection For Single Phase Motors

1-1/2 h.p. and 2 h.p. single phase masonry saw motors have a dual voltage capable. A 115-volt or 230 volt power supply can be used. To change voltage simply move the voltage change switch located on the front of the motor to the required voltage, no rewiring is required. Wherever possible, use 230-volt power supply for best operation.

BBC307 models are 230 volt only.



Failure to run the motor on the proper voltage will damage the motor and is not covered under warranty. Improperly wired motors are not covered under warranty.

BBC157 & BBC207 models are wired for 115 Volt from the factory!!!

Power Connections

Connect the power supply to the pigtail leads of the switch. Direct wiring connection is preferred, but an extension cord with an electrical plug with 30-amp minimum capacity may be used. A 30-amp circuit breaker is recommended. Connecting wires should be as short as possible and in one piece. In no case should the connecting wires be longer than shown in the following table for 1-1/2, 2, and 3 HP. Single-phase motors:

WIRE GAUGE	LENGTH OF WIRE	
	115 VOLT	230 VOLT
NUMBER 12	25 FEET	100 FEET
NUMBER 10	50 FEET	150 FEET
NUMBER 08	75 FEET	175 FEET

Caution-When wires that are too small gauge or too long are used, loss of power, over heating, or possible damage to the motor will result.



Always use the proper wiring connectors that are UL/CSA approved to attach the motor to the electrical supply. Any wiring hook ups should be made by qualified personal and made to National Electrical Code and to any Local Codes.

Generators:

If a generator must be used, it must be of 8kW or larger. The generator must have a 30A circuit and capable of providing a minimum of 8kW at the required voltage. Under size generators will cause motor damage and is not covered under warranty.

D. Wiring Diagram

Be sure to ground the saw properly before operating, such as a ground wire connection provided by the power company.

Electrical Connections

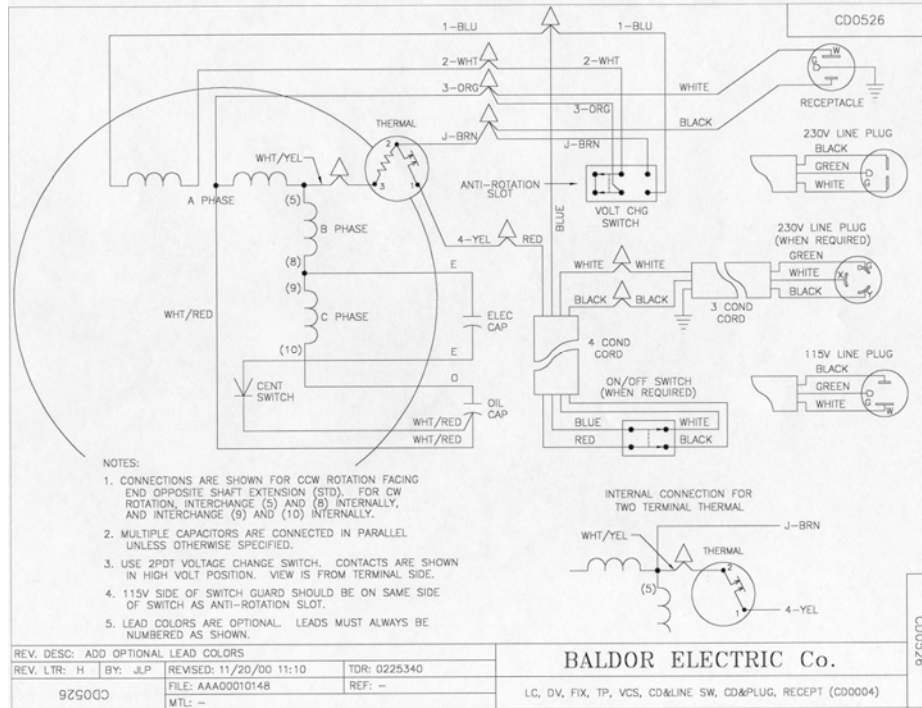

BBC 157 – 1-1/2HP 115-230v/60Hz/1 Phase

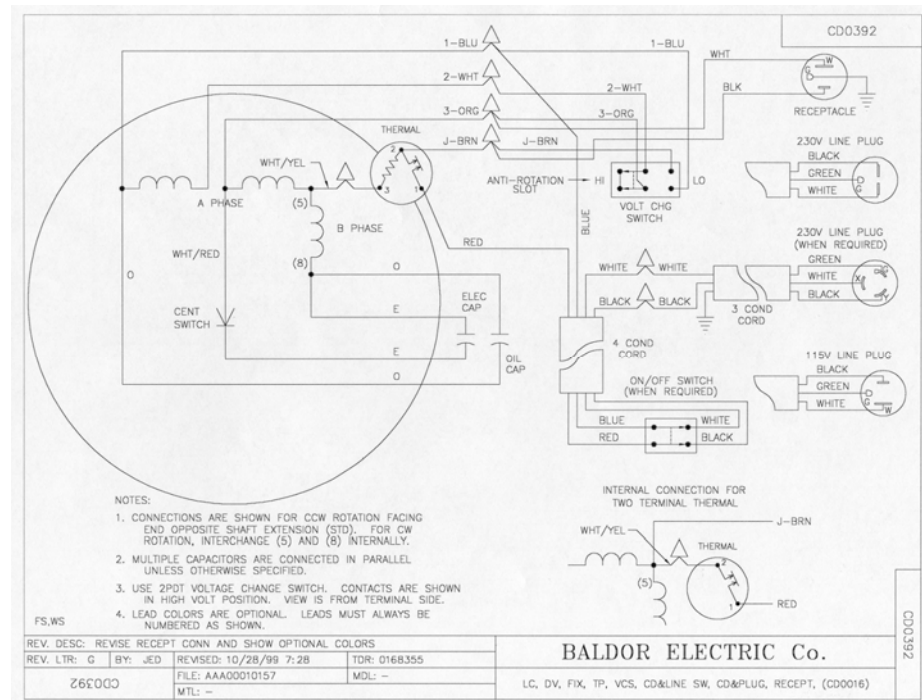

BBC207 – 2HP 115-230v/60Hz/1 Phase

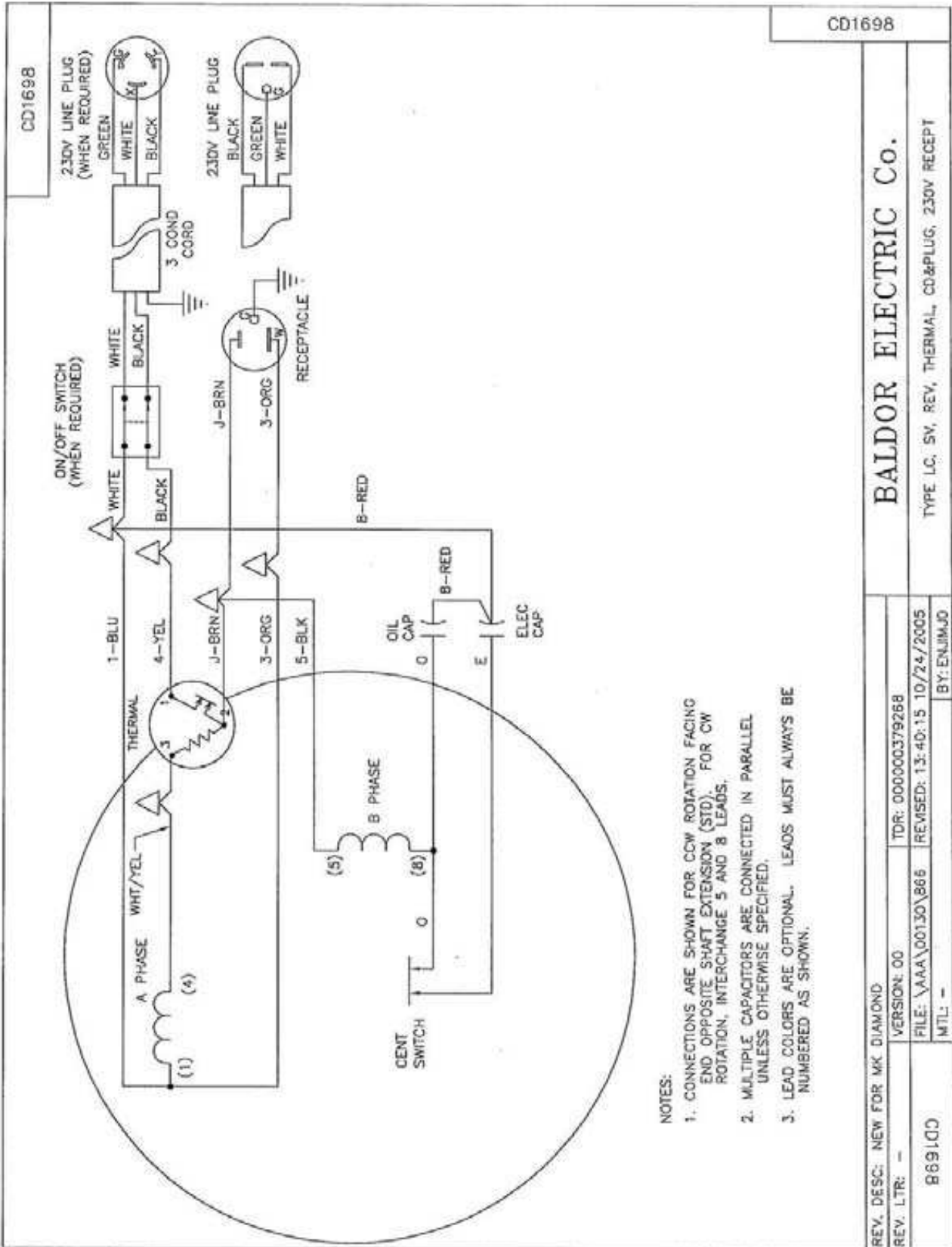

- NOTES:
1. CONNECTIONS ARE SHOWN FOR CCW ROTATION FACING END OPPOSITE SHAFT EXTENSION (STD). FOR CW ROTATION, INTERCHANGE 5 AND 8 LEADS.
 2. MULTIPLE CAPACITORS ARE CONNECTED IN PARALLEL UNLESS OTHERWISE SPECIFIED.
 3. LEAD COLORS ARE OPTIONAL. LEADS MUST ALWAYS BE NUMBERED AS SHOWN.

BBC307 – 3 HP 230v/60Hz/1 Phase

For any Electric Motor service, warranty, or technical related questions please contact your nearest Baldor service center:
 Baldor Electric Company
 5711 R.S. Boreham, Jr. St.
 P.O. Box 2400
 Fort Smith, AR 72901
 Phone: (501) 646-4711
 Fax: (501) 648-5792

I. PREPARATION

F. Gasoline Engine

Prior to attempting to operate the engine, read the information contained in the engine owner's manual. An engine owner's manual is supplied with every gasoline powered concrete saw.

1. **Check Oil:** Add oil if low. Refer to the engine owner's manual for the recommended SAE viscosity grades. Capacity of oil is 1.1 liters (1.16 US qt)
2. **Check Fuel:** Fill if low. Use only unleaded gasoline with a pump sticker octane rating of 86 or higher is recommended. **Never use an oil and gasoline mixture!**
3. **Air Cleaner:** Never run the engine without the air cleaner! Rapid engine wear will result from contaminants being drawn through the carburetor and into the engine.
4. **Engine Starting:** Refer to the engine owner's manual for proper engine starting procedure.



Make sure that the Cutting Head Depth Limiting Bolt Assembly is in the bottom position. The head on the Gasoline Powered Saw should only rise to a maximum of nine (9) inches above the surface of the Cutting Table

For any Engine service, warranty, or technical related questions please contact your nearest Honda service centers:

Honda Power Equipment Group
4900 Marconi Dr.
Alpharetta, GA 30005-8847
Tel: (800) 426-7701 | Fax: (678) 339-2670
Web page: <http://www.honda-engines.com/dis.htm>

II. OPERATION

A. Installing the Blade

1. For Gasoline powered machines disconnect the spark plug and for Electrical Powered Machines disconnect from power source.
2. Remove the blade shaft nut, (Turn clockwise), and remove the outside collar.
3. Clean off any foreign particles on the clamping surfaces of both collars and on the mounting surface of the blade.
4. Place the blade on the blade shaft.



Use only Norton Clipper Diamond Blades.

5. Slide the outside blade shaft collar onto the blade shaft.
6. Tighten the blade shaft nut (clockwise) securely against the outside collar by using the Blade Shaft Wrench 19mm and Blade Shaft Flat Wrench 22mm as show in the figure below

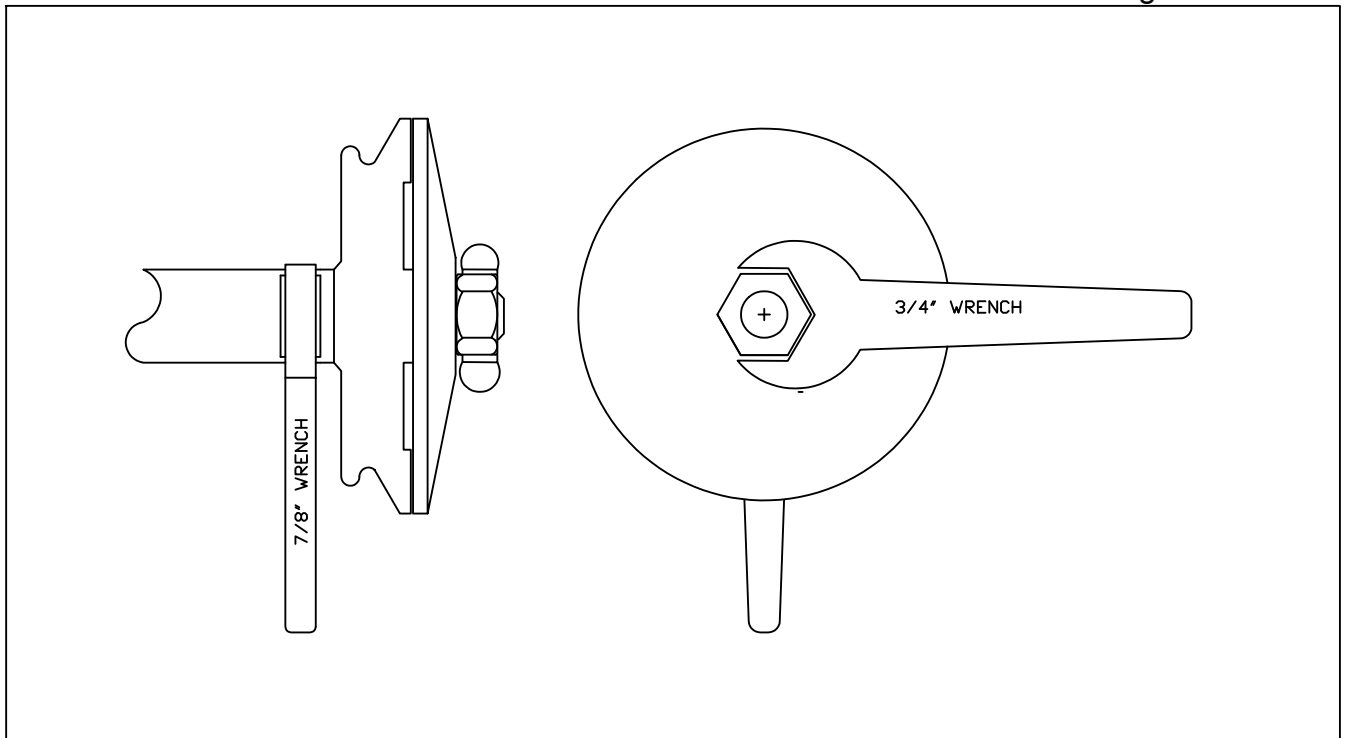

Figure 11: Blade Tightening

7. Reconnect the spark plug or reconnect the electrical power.

Use Only Norton Clipper Diamond Blades

II. OPERATION

B. How To Use " Step Cutting " With Abrasive Blades

Use "step cutting" without exception when cutting wet or dry with abrasive blades. "Jam cutting", which is discussed and illustrated in the section following, is to be used only with wet and dry cutting diamond blades.

1. Clamp and hold material firmly against the backstop on conveyor cart. Be certain the material does not slip or rock during cutting operation, as this can bind blade, causing excessive wear and fracture.
2. Move the conveyor cart near the blade, and pull down on the head until the blade is lowered to a point where it will lightly contact the top of the material. Then start "step cutting" - which means passing the material beneath the blade with rapid, (50 to 60 strokes per minute) full length strokes, taking a shallow cut (approximately 1/8" deep) on the forward, and also on the backward stroke. Complete each rapid stroke backward and forward, by passing the material beyond the center of the blade before starting the reverse movement of the cart. The harder the material, the more rapid the forward and backward strokes.
3. "Step cutting as can be seen in the sketch below, lessens the area of the blade circumference in contact with the material, keeping the blade cool, running free, and cutting at peak efficiency. Don't get the impression "step" cutting means slow cutting - actually it is 6 times faster than trying to "force" the cut by strong-arming the material through the blade. Forcing the blade through with a deep cut causes a longer area of the blade circumference to be in contact with the material, causing excessive friction heat to be generated, which then causes the blade to "smear" or "load" with fused material particles and lose its sharp cutting surface. *(Note: If improper operation should cause an abrasive blade to "smear", make several cuts through a soft brick to "dress" the blade back to good cutting performance.)*

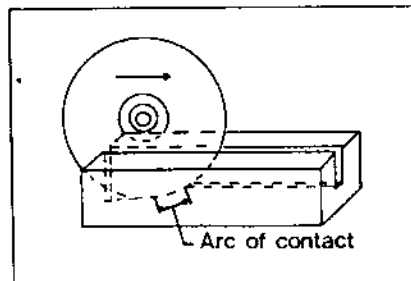

II. OPERATION

C. How To Use "Jam Cutting" (Fixed Cutting) and "Step Cutting" With Diamond Blades

In "Jam" cutting the head is locked in a fixed position and the material is pushed into it as shown in the sketch at the bottom. "Jam" cutting with the head locked in a fixed position usually provides greater efficiency.

1. To lock the head into position, tighten the lever nut at the back of the saw.
2. "Step" cutting with diamond blades is done by applying more pressure to the blade. Unlike "step" cutting with abrasive blades, "step" cutting with diamond blades requires only a few passes through the material.
3. In cutting, clamp the material securely and hold it firmly against the conveyor cart backstop. If the material is allowed to slip, resulting seizure of the blade may bend the diamond blade steel center or cause a ring section to be twisted off.
4. Do not force the material or bump into the blade. When nearing completion of the cut, retard and slightly hold back the conveyor cart. If this is not done, the material may be pulled into the blade so fast that excessive pressure on the rim may cause warping or twisting of the rim section.
5. When a new diamond blade is broken in, make the first few cuts slowly until the blade cuts freely and easily.
6. When the blade is cutting freely and easily. Use it! As long as it cuts satisfactorily do not dress the diamond blade or remove it from the blade shaft.
7. After continuous cutting of extremely hard and dense materials, the blade may slow down and it may be necessary to "dress" the cutting edge. To do this:
 - a. Use a rapid "step" cutting method for a few cuts - push the material back and forth under the blade while it is cutting down. If this is not sufficient:
 - b. Make one or two cuts in a soft brick or light weight block.

However, "dressing" should be done as seldom as possible - because too much "dressing" reduces blade life.

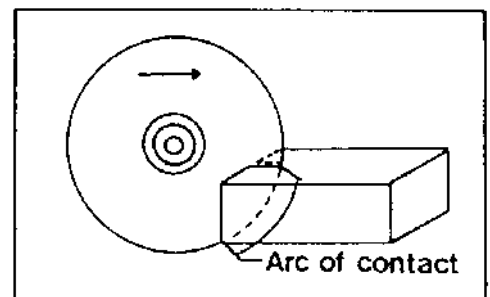

II. OPERATION

D. How To Use Blockbuster Compact For Dry Cutting

1. Use a proper blade, which is marked for dry cutting.
2. Remove the water curtain.
3. Disconnect the water pump.
4. Use "step" cutting as explained previously when using abrasive blades.
5. Use "jam" or "step" cutting when using dry cutting diamond blades.

E. How To Use Blockbuster Compact For Wet Cutting

Water may be supplied either by filling the water pan to within a half-inch of the top (for continuous use of the same water) or by placing a barrel of water next to the saw (for continuous flow of clean water). When using water from a barrel, remove water from pan and submerge it in water barrel. Remove the drain plug so the used water and sludge will drain from pan.

1. Prepare water supply.
2. Install water curtain on cutting head pivot bar.
3. Be sure the water pump is plugged into the receptacle on the back of the masonry saw motor. (The pump will start when the main switch is turned on.)
4. Handle on petcock should be turned in line with the water flow. Start motor and be certain that both sides of the blade are getting water.
5. Be sure that the water covers the bottom of the pump at all times. Do not let sludge and dirt get deep enough in the pan to block the pump inlet.
6. Use "step" cutting with abrasive blades as previously directed.
7. Use "jam" cutting or "step" cutting with diamond blades as previously described.

III. MAINTENANCE

The Blockbuster Compact requires very little maintenance for long satisfactory operation. However, the following points must be watched:

A. V-Belts

The drive belts are made of premium oil and heat resistant materials. They require very little adjustment, but should be tightened after the first few days of running.

Adjustment And Alignment

Warning: Never make adjustments to v-belts and pulleys while engine is running.

1. The best tension for a v-belt drive is the lowest tension at which the belts will not slip under full load. The normal tension is 3.8 to 5.4 lbf. approx. 1/2" deflection
2. Simply take up the drive until the belts are snug in the grooves. Run the drive for about 15 minutes to "seat" the belts. Then impose the peak load. If the belts slip, tighten them until they no longer slip at peak load.
3. Remember, too much tension shortens belt and bearing life.
4. Check belt tension frequently during the first day of operation. Check belt tension periodically thereafter and make any necessary adjustments.
5. The two most common causes of misalignment are shown in the drawing.
 - a). The engine drive shaft pulley and the blade shaft are not parallel.[See figure 1]
 - b). The pulleys are not located properly on the shafts.[See figure 2]
- 6). To check alignment, all you need is a steel straight edge.
- 7). Line up the straight edge along the outside face of both pulleys as shown in the drawing.
- 8). Misalignment will show up as a gap between the pulley face and the straight edge.
- 9). Make sure that the width of the outside land is equal on both pulleys.

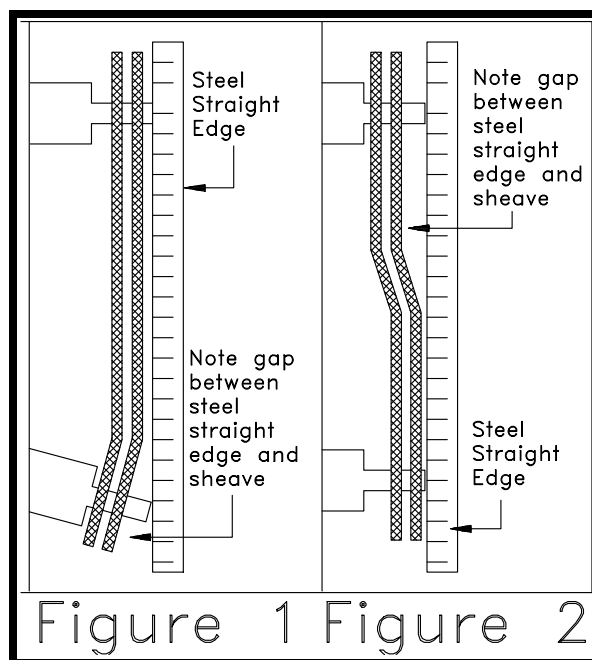

III. MAINTENANCE

B. Motor

The motors are specially designed for masonry sawing. It is totally enclosed and the sealed bearings require no lubrication. The motor is equipped with thermal overload protection.

1. Periodically clean the dirt and sludge build-up from the motor fan housing and cooling fins.
2. If the motor becomes overheated, the protector shuts the motor off. Turn the motor switch to the "OFF" and identify the cause of overheating.

For any Electric Motor service, warranty, or technical related questions please contact your nearest Baldor service center:

Baldor Electric Company
Corporate Headquarters
5711 R.S. Boreham, Jr. St.
P.O. Box 2400
Fort Smith, AR 72901
Phone: (501) 646-4711
Fax: (501) 648-5792
Web Page: <http://www.baldor.com/support/default.asp>

C. Engine

1. Refer to the engine owner's manual for complete maintenance.
 - a. Pre-cleaner: every 25 operating hours, more often in dusty or dirty conditions, wash and oil the pre-cleaner.
 - b. Paper Element: Every 100 operating hours, more often under dusty or dirty conditions clean the paper element.
 - c. Engine Oil: After the first month or 20 operating hours, change the oil, then every 6 months or 100 operating hours.

For any Engine service, warranty, or technical related questions please contact your nearest Honda service centers:

Honda Power Equipment Group
4900 Marconi Dr.
Alpharetta, GA 30005-8847
Tel: (800) 426-7701 | Fax: (678) 339-2670
Web page: <http://www.honda-engines.com/dis.htm>

D. Blade Shaft Bearings

The blade shaft bearings are lubricated and should not require daily lubrication under normal conditions. However, to assure long life the bearings do need to be lubricated periodically. The time interval between greasing is dependent on the running speed and operating conditions. The following chart covers most situations and can be used as a guide.

TEMPERATURE	CLEANLINESS	GREASING INTERVAL
*UP TO 150 F	Dirty	6 to 12 months
Over 150 F	Dirty	Daily to 2 Weeks
Any Temp	Very Dirty	Daily to 2 Weeks
Any Temp	Extreme Conditions	Daily to 2 Weeks

Note: Never operate saw without bearing cover in place.

For normal conditions the grease should conform to the NLGI grade two consistency and be free of any chemical impurities such as free acid or free alkali, dust, rust, metal particles or abrasives.

For best results, the bearings should be lubricated while in operation.

Note:

Due caution for personal safety must be observed when servicing rotating equipment.

If necessary to lubricate while the bearing is idle, refer to lubrication table for the maximum grease capacity for the bearings.

LUBRICATION OF SEALMASTER BEARINGS	
Shaft Sizes	Maximum Grease Capacity of Bearing Chamber in Ounces
1/2" to 3/4"	.09
7/8" to 1-3/16"	1/4
1-1/4" to 1-1/2"	3/8
1-11/16" to 1-15/16"	3/4
2" to 2-3/16"	1-1/8

E. Pump

The submersible pump require no lubrication for Gasoline powered machines mechanically driven pumps or the Electrical powered machines electrical pumps. The pump is designed to run wet or dry, but for continued dry cutting, disconnect the pump.

1. Be sure to keep the pump clean - do not allow sediment to cake in the pump and clog it.
2. Keep all lines clean and running free.
3. Do not allow the Flex-cable to be pinched by the blade guard or anything else for the mechanically driven units. Damage to the flex cable by pinching is not covered under any warranty. Do not pinch or cut the power supply cable for the electrical water pumps as this can cause a dangerous electrical short. Damage to the power supply cable is not covered under any warranty.

V. PARTS LIST SECTION

A. Ordering Information

1. List model number and serial number of machine.
2. List the part number and description of part (not item number).
3. Whenever alternate parts are shown due to product improvement, inspect the part you have and provide additional description as necessary.
4. Specify mode of shipping desired, for example, parcel post, truck, airfreight, U.P.S., best way, etc.

B. Parts List

See assembly drawing.

C. Power Unit Service Information

Repair or replacement service is available from your nearest authorized service station. Refer to the service center listing for the nearest authorized motor/engine service center.

V. PARTS LIST SECTION

Power Plant (BBC547-507) Gasoline

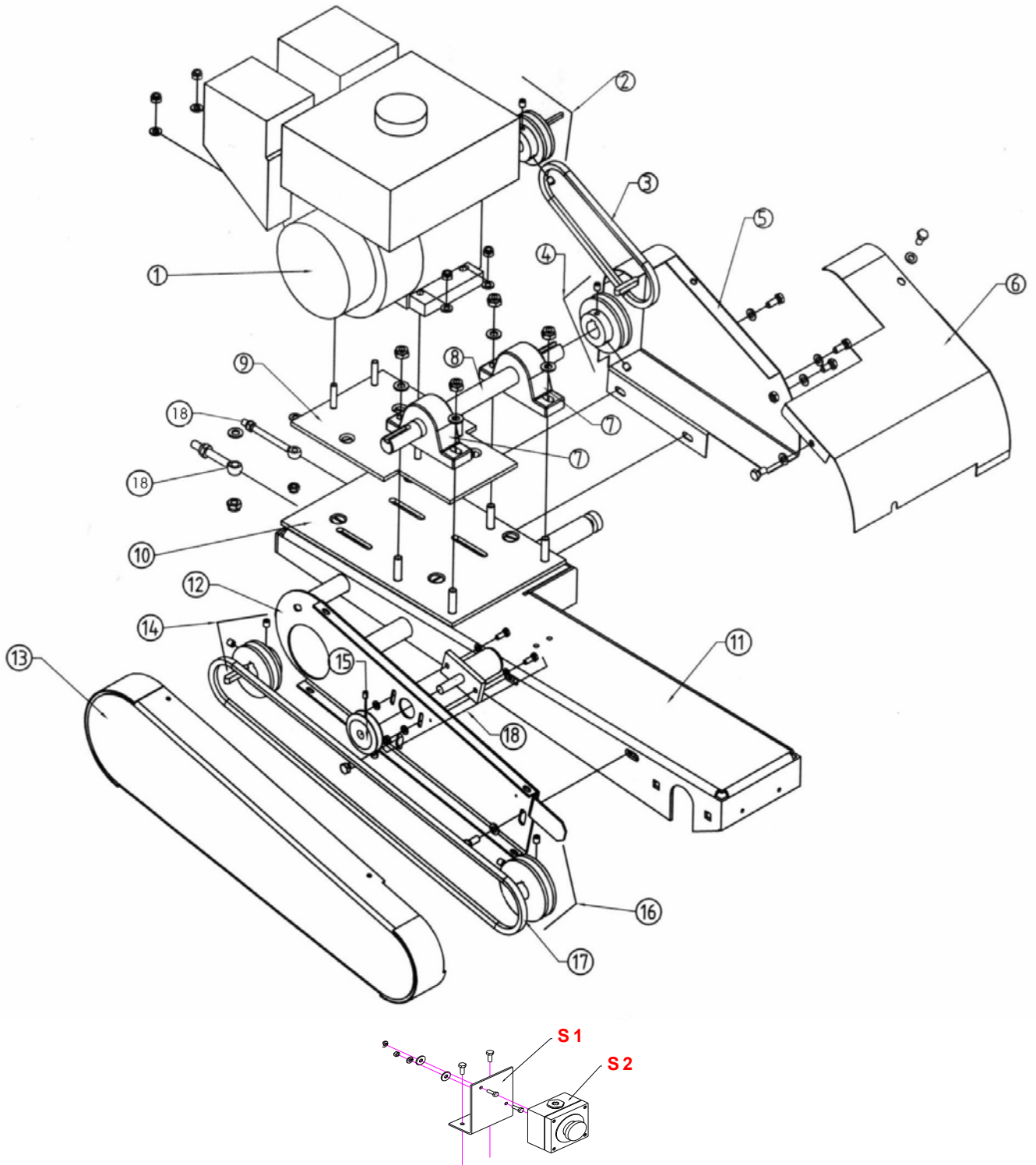

Power Plant (BBC547-507) Gasoline

Item No	Description	Part Number
1	Honda motor GX160	83715
2	Motor pulley	83716
3	Belt XPZ 562 LW	83717
4	Jackshaft pulley	83718
5	Right belt guard	83719
6	Guard for the jackshaft	83720
7	Bearing	70599
8	Jackshaft	83721
9	Motor fixation plate	83722
10	Jackshaft fixation plate	83723
11	Cutting head BBC 14"	83724
	Cutting head BBC 20"	232192
12	Support plate for belt guard 14" BBC only	83725
13	Belt guard for 14" BBC only	83726
14	Jackshaft pulley 14" BBC Only	76102
15	Water pump pulley	75270
16	Blade shaft pulley	76098
17	Belt XPZ 1280 LW BBC 14" Only	70398
18	Eyebolt with Hardware (1)	76015
S1	Switch support	83746
S2	Emergency stop switch	83745

Power Plant (BBC157-207-307) Electric

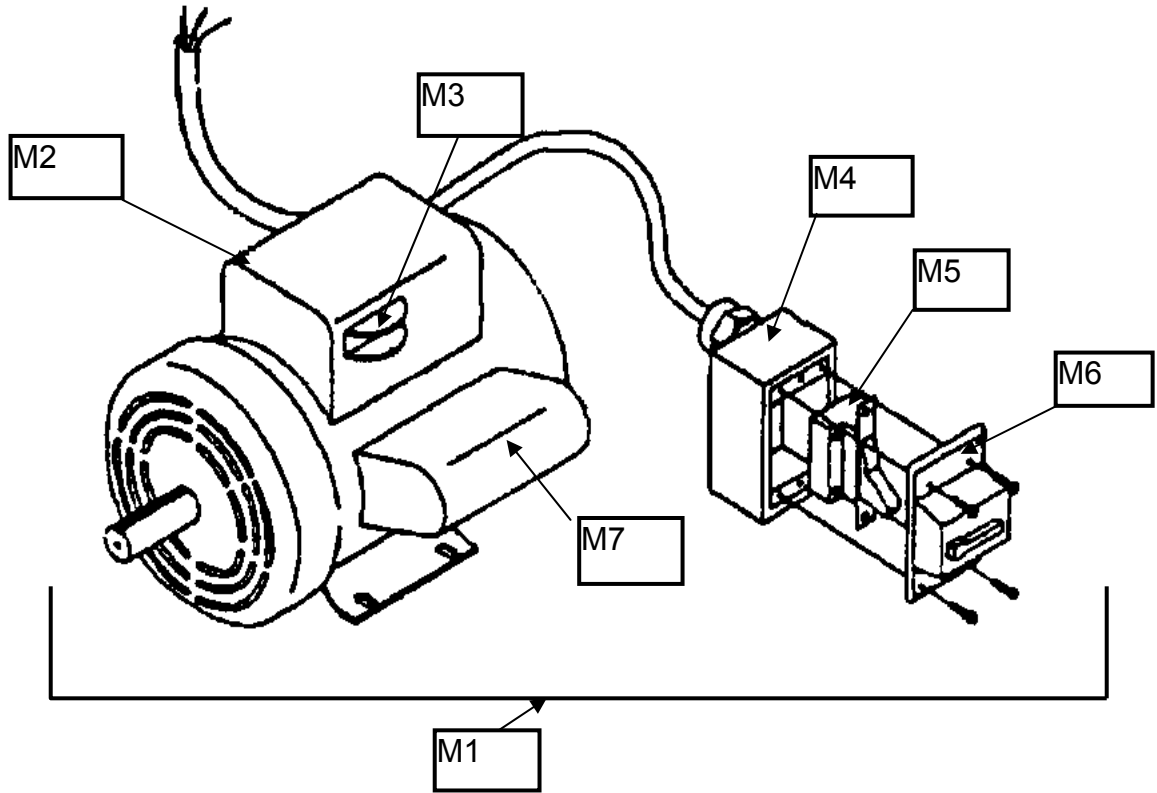

Item No	Description	Part Number
M1	Motor Assembly w/Switch 1-1/2HP 115/230v/60/1 Motor Assembly w/Switch 2 HP 115/230v/60/1 Motor Assembly w/Switch 3HP 230v/60/1	232084 232085 232160
M2	Capacitor Box Large (Terminal Box)	232085A
M3	Voltage Change Switch	231085
M4	Switch Box Rear	231087
M5	Switch On/Off	231088
M6	Switch Box Cover	231089
M7	Capacitor Box Small	231091
-NA-	Thermal Reset Button 1-1/2 HP TPMST24AB <i>NOTE: The Thermal Reset Button Is Located On The Rear Of The Large Capacitor Housing</i>	232129
-NA-	Thermal Reset Button 2 HP <i>NOTE: The Thermal Reset Button Is Located On The Rear Of The Large Capacitor Housing</i>	
-NA-	Pulley 68mm OD 24mmB 1G 4" Electric Models Only Key 8mm x 7mm x 24mm	83747 232198
-NA-	Belt XPZ 1500 LW (1) 14" Electric Models Only Belt XPZ 1850 LW (1) 20" Electric Models Only	72926 232191

Frame (Common All BBC157-207-307-547-507)

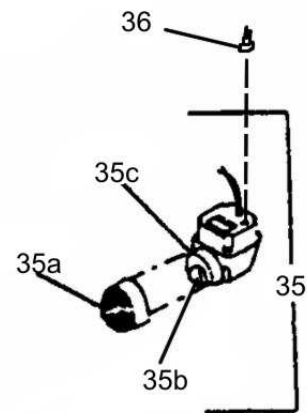
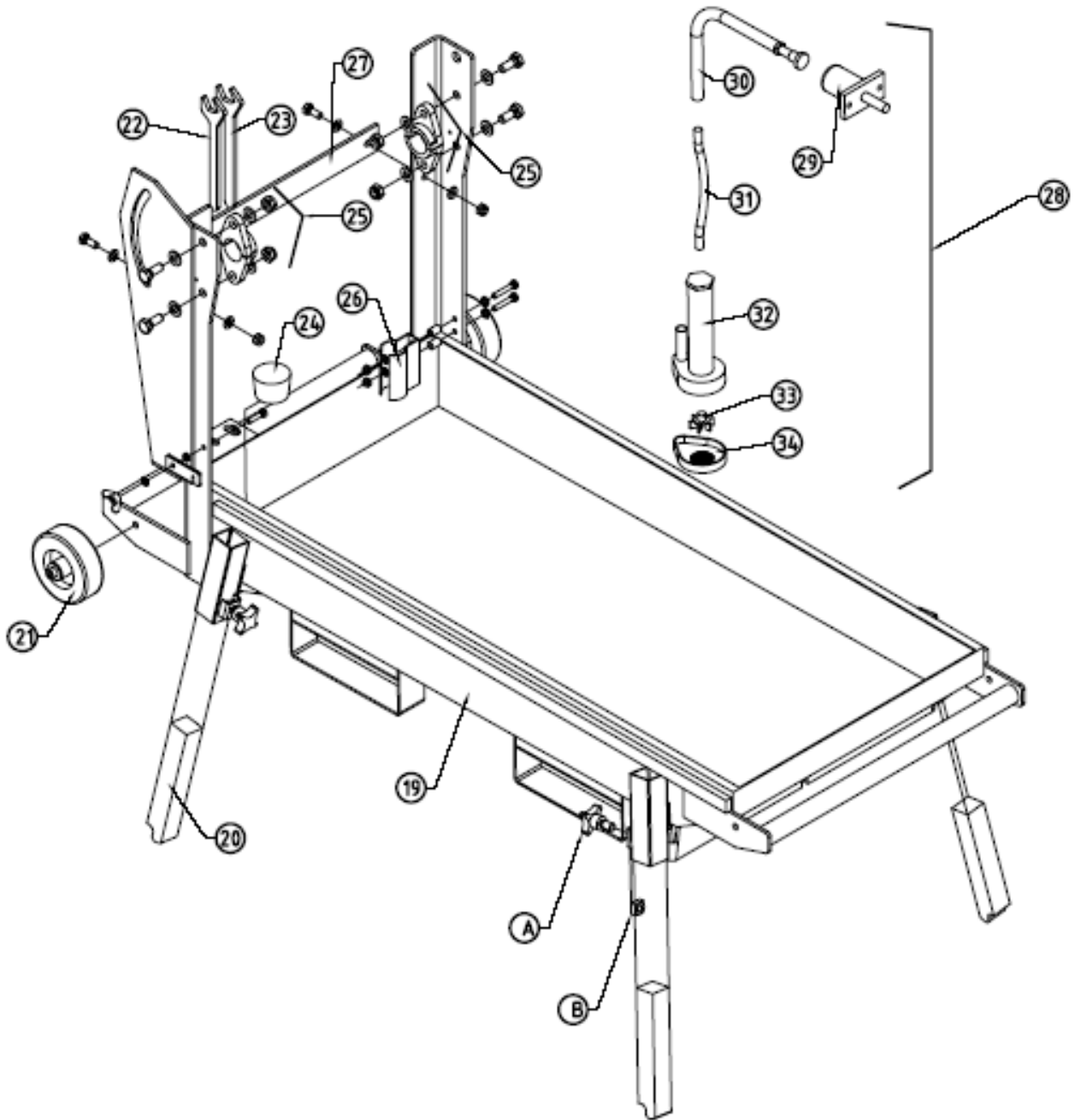

Electrical Water Pump

Frame (Common All BBC157-207-307-547-507)

Item No	Description	Part Number
18	Screws for water pump	75280
19	Frame	83727
20	Leg (Includes One (1) Leg) Sold Individually – Four (4) Required Per Machine	75817
21	Wheel	82733
22	Wrench 19mm	70807
23	Wrench 22mm	72143
24	Drain plug	76095
25	Split bearing	83728
26	Water pump fixation spring	76097
27	Support post	83729
28	Water pump complete Mechanical Pump	72305
29	Drive end comp. For water pump Mechanical Pump	72297
30	Sheath for flexible shaft Mechanical Pump (Not Available, Now part of 72307)	-NA- Part of 72307
31	Flexible shaft complete for mech. water pump L=35.8 inches (910mm)	72307
32	Body of the pump Mechanical Pump	72284
33	Propeller water pump Mechanical Pump	72862
34	Plastic sieve for pump Mechanical Pump	72186
34a	Knob M10 X 20 1.5 for Legs (sold each)	72856
34b	Nut M10 Square (sold each)	27065
35	Water Pump PE1 – Electric Powered Units Only	214169
35a	Screen Water Pump PE1	155775
35b	Impeller Water Pump PE1	155774
35c	Volute Water Pump PE1	101375
36	Fitting Barb Hose ¼" FPT X ½ MALE BARB	9602010

Cutting Head (Common All BBC157-207-307-547-507)

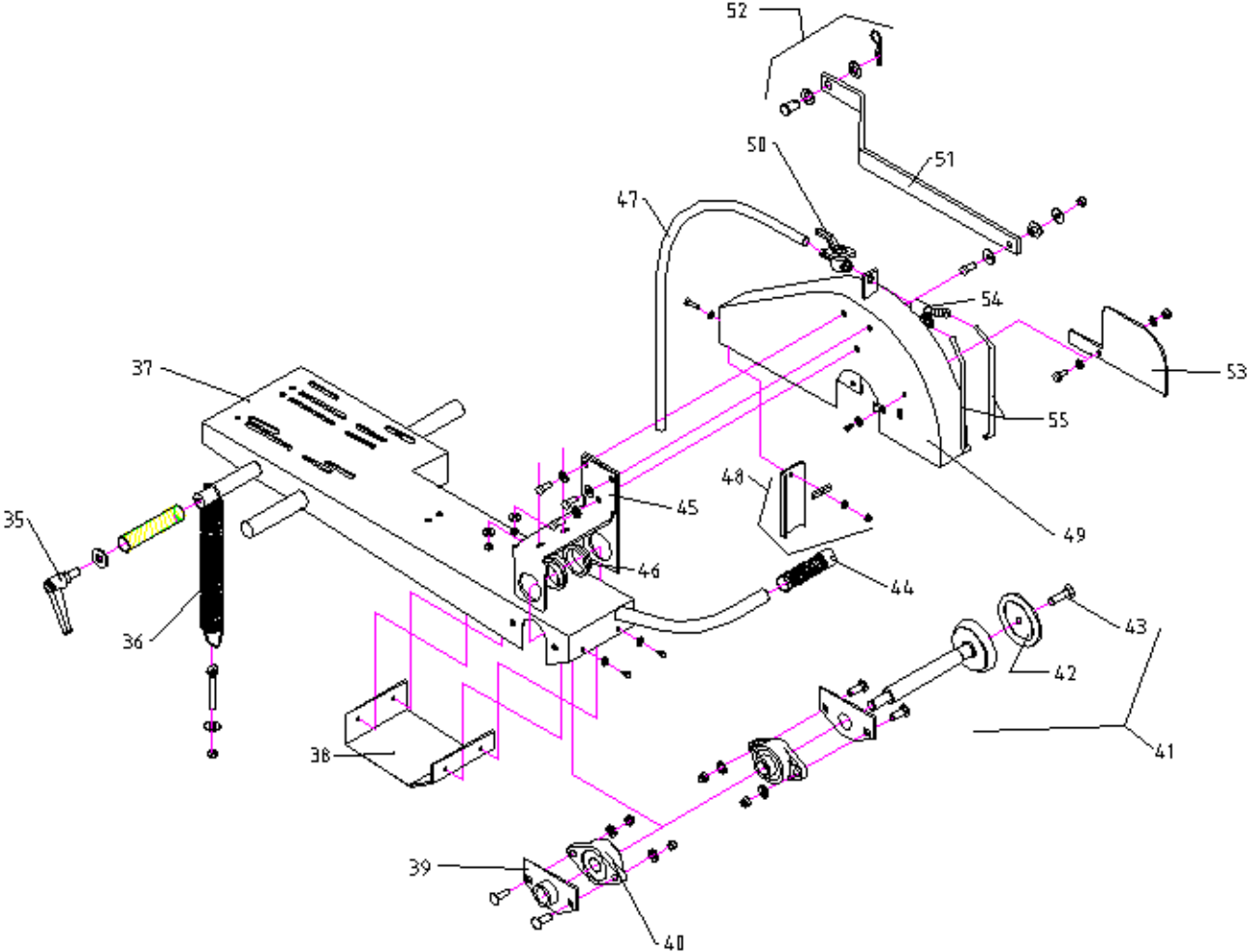

Cutting Head (Common All BBC157-207-547)

Item No	Description	Part Number
35	Locking Handle for cutting head (was 73098 replaced by 82738)	82738
36	Spring	72567
37	Cutting head BBC 14"	83724
	Cutting head BBC 20"	232192
38	Protection for Bearings and shaft	76111
39	Support for blade shaft bearing (set of 2)	76060
40	Bearing (set of 2)	73418
41	Blade shaft assembly 14" Models Only	76035
	Blade shaft assembly 20" Models Only	76556
42	Loose collar 14" Models Only	73216
	Loose collar 20" Models Only	73281
43	Screw for loose collar	73217
44	Handle grip	72097
45	Leveling support	76113
46	Bushings, bearing-Nylon (set of 2)	73220
47	Hose for water pump	72413
48	Splash guard	73221
49	Blade guard 14"	76037
	Blade guard 20"	76126
50	Water tap	72357
51	Stay-level arm	73266
52	Kit stay-level arm pin	76039
53	Blade shaft vent cover	76109
54	Y distributor	72286
55	Spray nozzle (set of 2)	80568

Cutting Table (Common All BBC157-207-307-547-547)

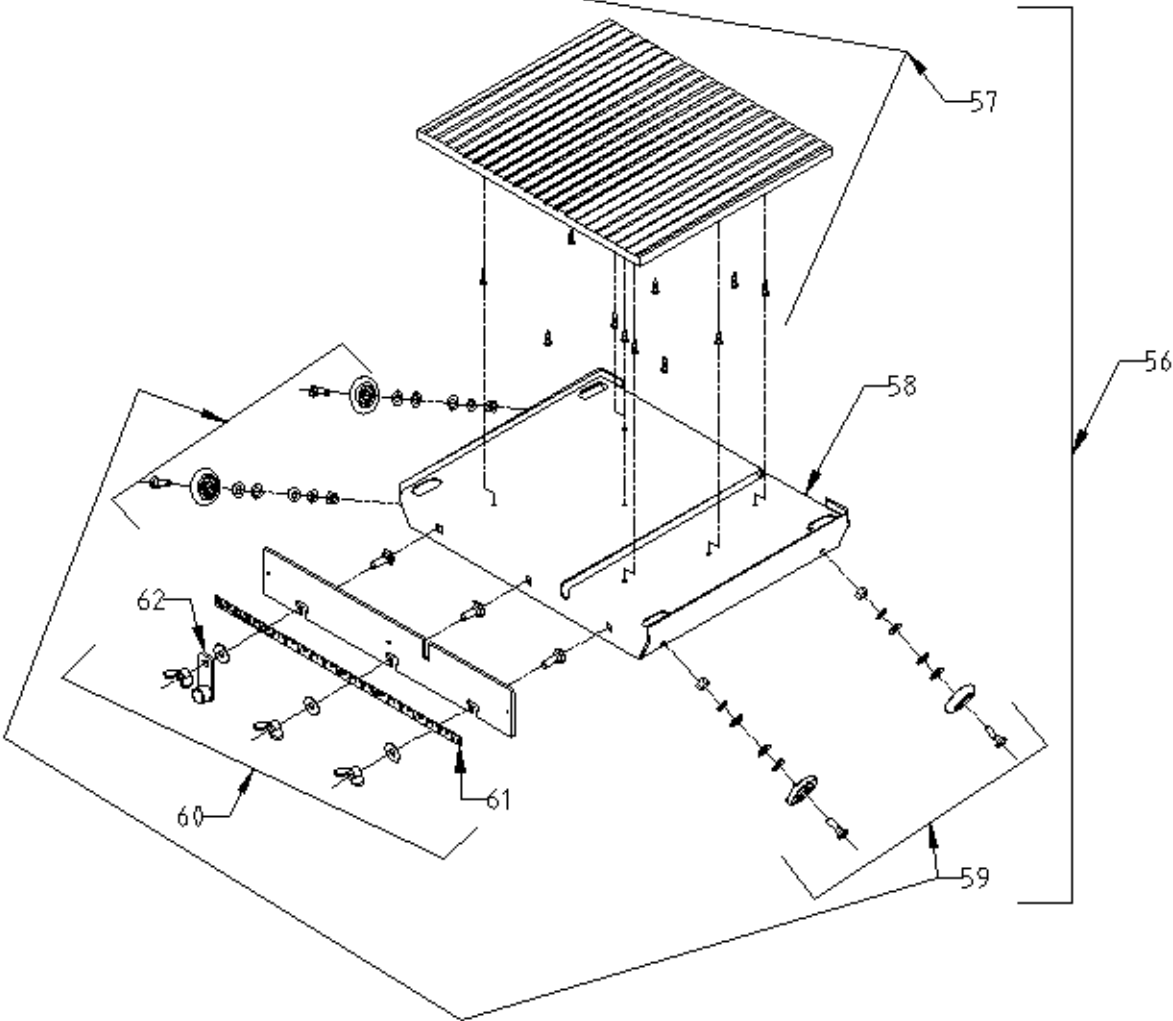

Cutting Table (Common All BBC157-207-547)

Item No	Description	Part Number
56	Conveyor Cart (aka Cutting Table) Complete With Wheels, Top, Back Stop, and Conveyor Cart Stop	83754
57	Top For Cutting Table (Wood & Rubber) w/Hardware	76742
	Screw 4x 12mm DIN 7976 (sold each, 11 required)	30373
58	Conveyor Cart Frame Only (No Wheels, Top, Backstop or Conveyor Cart Stop)	-NA- Part of 83754
59	Wheel Kit, Conveyor Cart (Set Of 4) w/Hardware	75333
	Carriage Bolt M10 x 30 DIN 603 (sold each, 3 required)	27282
	Washer 10.5 DIN 9021 (sold each, 3 required)	27508
	Wing Nut M10 DIN 315 (sold each, 3 required)	27040
60	Back Stop Plate	83752
61	Scale for Conveyor Cart w/rivets	83753
62	Stop Assembly for Conveyor Cart (Complete)	82856
	Rubber Stop	-NA- Part of 82856
	Nut M6 DIN 439	27003
	Washer M6 DIN 125	27539

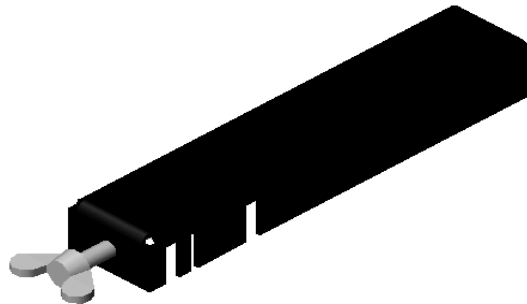

Item No	Description	Part Number
-NA-	Guide-A-Cut Assembly	83892

C. Baldor Service Policy



SERVICE POLICY AND AUTHORIZED SERVICE CENTERS

SERVICE POLICY AND LIMITED WARRANTY

DATA SECTION

505

December 15, 1991

REPLACES
DATA SECTIONS
505 AND 505 C
DATED JANUARY, 1990

- 1) Baldor electric motors are warranted for a period of one (1) year, from date of shipment from the factory or factory warehouse against defects in material and workmanship. To allow for stocking and/or fabrication period and, also, one year of actual service, the warranty period will be extended for an additional period of six months, or a total of eighteen (18) months after date of shipment from factory or factory warehouse stock. In no case will the warranty be extended for a longer period. Baldor extends this limited warranty to each buyer of the electric motor for the purpose of resale and to the original purchaser for use.
- 2) Baldor will, at its option, repair or replace a motor which fails due to defects in material or workmanship during the warranty period if:
 - (a) the purchaser presents the defective motor at, or ships it prepaid to, the Baldor plant in Fort Smith, Arkansas or one of the Baldor Authorized Service Centers, which are listed below; and
 - (b) the purchaser gives written notification concerning the motor and the claimed defect including the date purchased, the task performed by the Baldor electric motor, and the problem encountered.
- 3) Baldor will not absorb the cost of removal of any electric motors from any equipment, the cost of delivery to Fort Smith, Arkansas or a Baldor Authorized Service Center, or the cost of any incidental or consequential damages resulting from the claimed defects. (Some states do not allow the exclusion or limitation of incidental or consequential damages, so the above exclusion may not apply to you.) Any implied warranty given by laws shall be limited to the duration of the warranty period hereunder. (Some states do not allow limitations on how long an implied warranty lasts, so the above limitation may not apply to you.)
- 4) Baldor Authorized Service Centers, when convinced to their satisfaction that a Baldor motor developed defects in material or workmanship within the warranty period, are authorized to proceed with the required repairs to fulfill Baldor's warranty when the cost of such repairs to be absorbed by Baldor does not exceed Baldor's warranty repair allowance. Baldor will not absorb overtime or premium repair charges without prior authorization.
- 5) The cost of warranty repairs made by other than Baldor Authorized Service Centers WILL NOT be absorbed unless first authorized by Baldor.
- 6) Claims of a purchaser that a motor is defective even when a failure results within an hour or less after being placed in service are not always justified. Therefore, Baldor Authorized Service Centers must determine from the condition of the motor as delivered to the Center whether or not the motor is defective, if, in the opinion of a Baldor Authorized Service Center, a motor did not fail as a result of defects in material or workmanship, the Center is to proceed with repairs only if the owner agrees to pay for them. If the decision is in dispute, the owner should still pay for the repairs and submit the paid invoice and the Authorized Service Center's signed service report to Baldor for further consideration. The matter will then be handled direct by Baldor with the owner or those who present the claim for adjustment.
- 7) This warranty gives you specific legal rights, and you may also have other rights which vary from state to state.

CENTRES DE SERVICE AUTORISES AU CANADA NOTRE GARANTIE

- 1) Les moteurs électriques Baldor sont garantis pour une période d'un (1) an, à partir de leur date d'expédition de la manufacture ou de l'entrepôt de la manufacture contre tous défauts de matériel et de main d'oeuvre. Allouant pour la marchandise en main et/ou la période de fabrication et, aussi, pour un an actuellement en service, cette garantie sera extensionnée d'une période additionnelle de six mois ou, un total de dix-huit (18) mois à partir de la date d'expédition de notre manufacture ou entrepôt de notre manufacture. Cette garantie ne sera d'aucune façon prolongée pour une plus longue période.
- 2) A sa discrétion, Baldor réparera ou remplacera, F.O.B. Fort Smith, Arkansas, ou du plus proche Centre de Service Autorisé Baldor, à ses dépens, tout moteur défectueux pour cause de matériel ou de main d'oeuvre durant la durée de cette garantie.
- 3) Baldor ne sera pas responsable pour le coût d'enlèvement de ses moteurs de l'équipement qu'ils font tourner, ni du coût de livraison de ses moteurs à ou de Fort Smith, ou du Centre de Service Autorisé Baldor, ni du coût des dommages conséquents résultant de défauts de ces moteurs.
- 4) Lorsqu'un Centre de Service Autorisé de Baldor sera convaincu à sa satisfaction qu'un moteur a développé un défaut en dedans de la période de garantie, il sera autorisé à procéder aux réparations requises pour remplir notre garantie quand le coût de ces réparations n'excèdera pas le montant de réparation alloué par Baldor. Cependant dans les situations d'urgence, nous pourrions si on le juge nécessaire autoriser les travaux de réparation.
- 5) Le coût réparation alloué par d'autres que les Centres de Service Autorisés de Baldor ne sera pas absorbé par nous à moins d'avoir d'abord obtenu notre autorisation.
- 6) Les réclamations d'un propriétaire de ces moteurs, devenus défectueux même en dedans d'une heure de leur mise en service ne sont pas toujours justifiables. Conséquemment les Centres de Service Autorisés Baldor doivent déterminer par la condition du moteur au moment qu'il leur est livré, si oui ou non ce moteur est défectueux. Si, dans l'opinion du Centre de Service Autorisé Baldor, le défaut de moteur n'est pas dû à un défaut de matériel ou de main d'oeuvre, il ne devra procéder à la réparation seulement si le propriétaire s'engage à en payer le coût. S'il y a dispute, le propriétaire devra quand même en payer le coût et ensuite soumettre la facture et le rapport du Centre de Service Autorisé Baldor à Baldor pour considération. Le problème sera alors résolu, avec le propriétaire où la partie qui présentera la réclamation pour ajustement, directement par Baldor.

TECHNICAL & CONSUMER INFORMATION

Warranty Service Information

Serviceing dealership personnel are trained professionals. They should be able to answer any question you may have. If you encounter a problem that your dealer does not solve to your satisfaction, please discuss it with the dealership's management. The Service Manager or General Manager can help. Almost all problems are solved in this way.

If you are dissatisfied with the decision made by the dealership's management, contact the Honda Power Equipment Customer Relations Office. You can write:

American Honda Motor Co., Inc.
Power Equipment Division
Customer Relations Office
4475 River Green Parkway
Duluth, Georgia 30136-2565

Or telephone: (770) 497-6400

When you write or call, please give us this information:

- Model and serial numbers (see page 47)
- Name of the dealer who sold the engine to you
- Name and address of the dealer who services your engine
- Date of purchase
- Your name, address, and telephone number
- A detailed description of the problem

NOTES

Saint-Gobain Abrasives

2770 West Washington

Stephenville, TX 76401

Phone: 254-918-2310

Fax: 254-918-2312



WARNING

Some dust created by power sanding, sawing, grinding, drilling, and other construction activities contains chemicals known to cause cancer, birth defects or other reproductive harm. Some examples of these chemicals are:

- **Lead from lead-based paints,**
- **Crystalline silica from bricks and cement and other masonry products, and**
- **Arsenic and chromium from chemically-treated lumber.**

Your risk from these exposures varies, depending on how often you do this type of work. To reduce your exposure to these chemicals: work in a well ventilated area, and work with approved safety equipment, such as those dust masks that are specially designed to filter out microscopic particles.