

G



JAY R. SMITH MFG. CO.
 MEMBER OF MORRIS GROUP INTERNATIONAL
 POST OFFICE BOX 3237
 MONTGOMERY, ALABAMA 36109-0237 (USA)
 TEL: 334-277-8520 FAX: 334-272-7396 www.jrsmith.com



MEMBER OF:

LOCATION

CAULK FERRULE CLEANOUTS WITH ACCESS COVERS

LEAD SEAL PLUG WITH ROUND COVER

FUNCTION: Used in hub openings in drainage piping where a cleanout is required. The straight thread lead seal plug permits quick and easy removal. Grooves on outside of ferrule prevent turning. Face-of-wall cover is desirable on finished walls when ferrule is used in vertical piping.

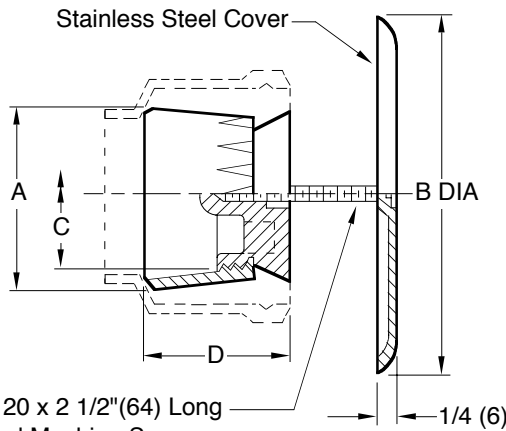

1/4(6) - 20 x 2 1/2(64) Long Flat Head Machine Screw

COUNTERSUNK PLUG

- Fig. 4400C LESS COVER AND SCREW
- Fig. 4402C WITH COVER AND SCREW

A SIZE	B DIA	C SIZE	D
02 (50)	4 1/4 (110)	1 1/2 (38)	2 1/2 (64)
03 (80)	5 1/2 (140)	2 1/2 (64)	2 3/4 (70)
04 (100)	5 1/2 (140)	3 1/2 (89)	3 (76)
05 (125)	7 (180)	4 1/2 (115)	3 (76)
06 (150)	9 1/4 (235)	5 1/2 (140)	3 (76)

REGULARLY FURNISHED:

Duco Cast Iron Caulk Ferrule and Cast Iron Lead Seal Plug with Stainless Steel Round Cover and Screw when indicated by Fig. Number.

VARIATIONS:

- Longer Screw 6"(150) Lg. -LS
- "T" Handle Plug -TH
- Plug tapped 1/4"(6) - 20 Thread
- Vandal Proof Screw -U

OPTIONAL MATERIALS:

- Cast Bronze Body -BB
- Cast Bronze Plug -BP
- Polished Bronze Cover -PB
- Prime Coated Steel Cover -PC

NOTE: Dimensions shown in parentheses are in millimeters.

DRAWING NUMBER
S4400

SIZE
A

SCALE:
NONE

DATE:
2-16-70

APPROVED BY:
JM

CHECKED BY:
BH

DRAWN BY:
RK

FIGURE NUMBER
4400, 4402

WE CAN ASSUME NO RESPONSIBILITY FOR USE OF SUPERSEDED OR VOID DATA

REV.	DATE	DESCRIPTION	BY	CKD. BY	WEIGHT POUNDS	VOLUME CUBIC FEET	FIGURE NUMBER
							4400, 4402

G
F
E
D

10-7-14
7-15-13
8-11-97
1-9-96

Revised Variations
Rev. Table
Chg'd Var & Opt Mat
Added Millimeters

TBW
TBW
EMB
EMB

BW
CL
BS
BS