



UNVENTED (VENT-FREE) NATURAL GAS LOG HEATERS OWNER'S OPERATION AND INSTALLATION MANUAL

For more information, visit www.desatech.com

18", 24", and 30" Variable
Manually-Controlled Models

CGD3018N **CGD3924N**
CGD3930N **CRL2718N**
CCL3924N **CRL3124N**
CCL3018N

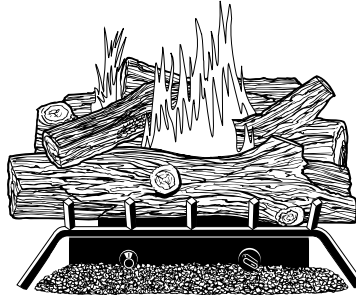

18", 24" and 30"
Thermostatically-Controlled
Models

CGD3924NT **CGD3930NT**
CGD3018NT **CCL3018NT**
CCL3924NT **CCL3930NTA**

(Smoky Mountain Oak Model Shown)

BILTMORE SPLIT OAK, SEASONAL OAK, AND SMOKY MOUNTAIN OAK LOGS

Variable Manually-Controlled Models Also Designed Certified
As Vented Decorative Appliance



Patent Pending

WARNING: If the information in this manual is not followed exactly, a fire or explosion may result causing property damage, personal injury, or loss of life.

- Do not store or use gasoline or other flammable vapors and liquids in the vicinity of this or any other appliance.
- **WHAT TO DO IF YOU SMELL GAS**
 - Do not try to light any appliance.
 - Do not touch any electrical switch; do not use any phone in your building.
 - Immediately call your gas supplier from a neighbor's phone. Follow the gas supplier's instructions.
 - If you cannot reach your gas supplier, call the fire department.
- Installation and service must be performed by a qualified installer, service agency, or the gas supplier.

WARNING: Improper installation, adjustment, alteration, service, or maintenance can cause injury or property damage. Refer to this manual for correct installation and operational procedures. For assistance or additional information consult a qualified installer, service agency, or the gas supplier.

WARNING: This appliance is for installation only in a solid-fuel burning masonry or UL127 factory-built fireplace, or in an approved ventless firebox. It is design-certified for these installations in accordance with ANSI Z21.11.2.

Exception: Do not install this appliance in a factory-built fireplace that includes instructions stating it has not been tested or should not be used with unvented gas logs.

WARNING: This is an unvented gas-fired heater. It uses air (oxygen) from the room in which it is installed. Provisions for adequate combustion and ventilation air must be provided. Refer to *Air for Combustion and Ventilation* section on page 4 of this manual.

This appliance may be installed in an aftermarket,* permanently located, manufactured (mobile) home, where not prohibited by local codes.

This appliance is only for use with type of gas indicated on the rating plate. This appliance is not convertible for use with other gases.

* Aftermarket: Completion of sale, not for purpose of resale, from the manufacturer

Save this manual for future reference.



TABLE OF CONTENTS

SAFETY INFORMATION	2	TROUBLESHOOTING	22
PRODUCT IDENTIFICATION	3	OPTIONAL POSITIONING OF THERMOSTAT SENSING BULB ..	25
UNPACKING	4	ILLUSTRATED PARTS BREAKDOWN AND PARTS LIST	26
LOCAL CODES	4	REPLACEMENT PARTS	36
PRODUCT FEATURES	4	SERVICE HINTS	36
AIR FOR COMBUSTION AND VENTILATION	4	TECHNICAL SERVICE	36
INSTALLATION	7	ACCESSORIES	36
OPERATING HEATER	17	OWNER'S REGISTRATION	37
INSPECTING BURNERS	20	PARTS CENTRAL	39
CLEANING AND MAINTENANCE	20	WARRANTY INFORMATION	Back Cover
SPECIFICATIONS	21		

SAFETY INFORMATION

WARNINGS

IMPORTANT: Read this owner's manual carefully and completely before trying to assemble, operate, or service this heater. Improper use of this heater can cause serious injury or death from burns, fire, explosion, electrical shock, and carbon monoxide poisoning.

 DANGER: Carbon monoxide poisoning may lead to death!

Carbon Monoxide Poisoning: Early signs of carbon monoxide poisoning resemble the flu, with headaches, dizziness, or nausea. If you have these signs, the heater may not be working properly. **Get fresh air at once!** Have heater serviced. Some people are more affected by carbon monoxide than others. These include pregnant women, people with heart or lung disease or anemia, those under the influence of alcohol, and those at high altitudes.

Natural Gas: Natural gas is odorless. An odor-making agent is added to the gas. The odor helps you detect a gas leak. However, the odor added to the gas can fade. Gas may be present even though no odor exists.

Make certain you read and understand all warnings. Keep this manual for reference. It is your guide to safe and proper operation of this heater.

 WARNING: Any change to this heater or its controls can be dangerous.

 WARNING: Do not allow fans to blow directly into the fireplace. Avoid any drafts that alter burner flame patterns. Ceiling fans can create drafts that alter burner flame patterns. Altered burner patterns can cause sooting.

 WARNING: Do not use a blower insert, heat exchanger insert or other accessory not approved for use with this heater.

Due to high temperatures, the appliance should be located out of traffic and away from furniture and draperies.

Do not place clothing or other flammable material on or near the appliance. Never place any objects on the heater.

Heater base assembly becomes very hot when running heater. Keep children and adults away from hot surface to avoid burns or clothing ignition. Heater will remain hot for a time after shutdown. Allow surface to cool before touching.

Carefully supervise young children when they are in the room with heater.

You must operate this heater with a fireplace screen in place. Make sure fireplace screen is closed before running heater.

Keep the appliance area clear and free from combustible materials, gasoline, and other flammable vapors and liquids.

SAFETY INFORMATION

Continued

- This appliance is only for use with the type of gas indicated on the rating plate. This appliance is not convertible for use with other gases.
- This heater shall not be installed in a bedroom or bathroom, unless installed as a vented appliance (Variable Manually-Controlled Models Only). See *Installing Damper Clamp Accessory for Vented Operation*, page 10.
- If you smell gas
 - shut off gas supply
 - do not try to light any appliance
 - do not touch any electrical switch; do not use any phone in your building
 - immediately call your gas supplier from a neighbor's phone. Follow the gas supplier's instructions
 - if you cannot reach your gas supplier, call the fire department
- Before installing in a solid fuel burning fireplace, the chimney flue and firebox must be cleaned of soot, creosote, ashes, and loose paint by a qualified chimney cleaner. Creosote will ignite if highly heated. Inspect chimney flue for damage. If damaged, operate heater with flue damper closed.
- If fireplace has glass doors, never operate this heater with glass doors closed. If you operate heater with doors closed, heat buildup inside fireplace will cause glass to burst. Also if fireplace opening has vents at the bottom, you must open the vents before operating heater.
- This log heater is designed to be smokeless. If logs ever appear to smoke, turn off heater and call a qualified service person. **Note:** During initial operation, slight smoking could occur due to log curing and heater burning manufacturing residues.
- To prevent the creation of soot, follow the instructions in *Cleaning and Maintenance*, page 20.
- Before using furniture polish, wax, carpet cleaner, or similar products, turn heater off. If heated, the vapors from these products may create a white powder residue within burner box or on adjacent walls or furniture.
- This heater needs fresh, outside air ventilation to run properly. This heater has an Oxygen Depletion Sensing (ODS) safety shutoff system. The ODS shuts down the heater if not enough fresh air is available. See *Air for Combustion and Ventilation*, pages 4 through 6. If heater keeps shutting off, see *Troubleshooting*, pages 22 through 24.
- Do not run heater
 - where flammable liquids or vapors are used or stored
 - under dusty conditions
- Do not use this heater to cook food or burn paper or other objects.
- Do not use heater if any part has been exposed to or under water. Immediately call a qualified service technician to inspect the room heater and to replace any part of the control system and any gas control which has been under water.
- Do not operate heater if any log is broken. Do not operate heater if a log is chipped (dime-sized or larger).
- Turn heater off and let cool before servicing. Only a qualified service person should service and repair heater.
- Operating heater above elevations of 4,500 feet could cause pilot outage.
- Provide adequate clearances around air openings.

PRODUCT IDENTIFICATION

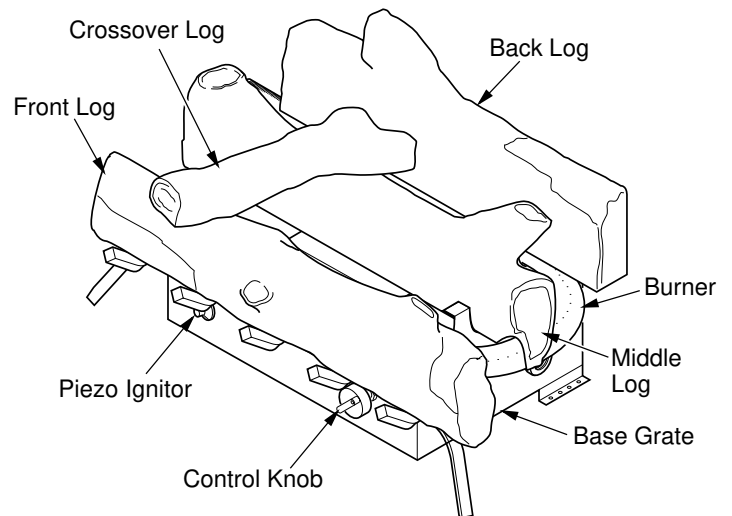

Figure 1 - Vent-Free Gas Log Heater - Duel Burner (Logs May Vary by Model - Smoky Mountain Oak Logs Shown)

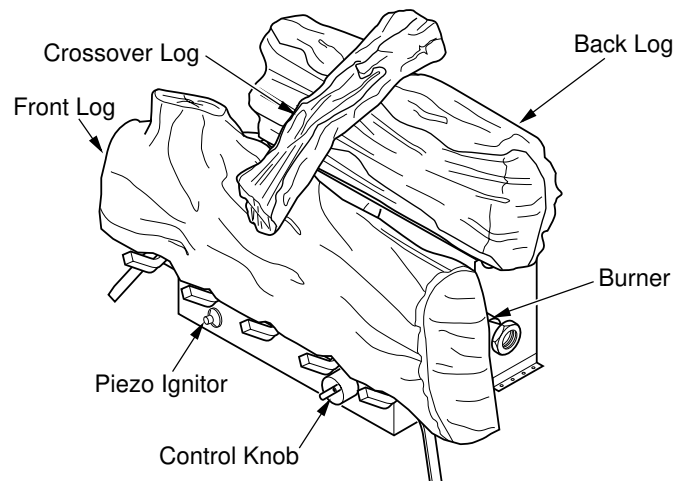

Figure 2 - Vent-Free Gas Log Heater - Single Burner (Logs May Vary by Model - Seasonal Oak Model Shown)

**UNPACKING
LOCAL CODES
PRODUCT FEATURES**

**Operation
Safety Pilot
Piezo Ignition System
AIR FOR COMBUSTION AND VENTILATION**

UNPACKING

⚠ CAUTION: Do not remove the data plates from the grate assembly. The data plates contain important product information.

1. Remove logs and heater base assembly from carton. *Note:* Do not pick up heater base assembly by burners. This could damage heater. Always handle base assembly by grate.
2. Remove all protective packaging applied to logs and heater for shipment.
3. Check all items for any shipping damage. If damaged, promptly inform dealer where you bought heater.

LOCAL CODES

Install and use heater with care. Follow all local codes. In the absence of local codes, use the latest edition of *The National Fuel Gas Code, ANSI Z223.1/NFPA 54**.

*Available from:

American National Standards Institute, Inc.
1430 Broadway
New York, NY 10018

National Fire Protection Association, Inc.
Batterymarch Park
Quincy, MA 02269

Note: Where listed vented decorative logs are required, thermostat models are not permitted.

PRODUCT FEATURES

OPERATION

This heater is clean burning. It requires no outside venting. There is no heat loss out a vent or up a chimney. Heat is generated by realistic, dancing yellow flames. This heater is designed for vent-free operation with flue damper closed. It has been tested and approved to ANSI Z21.11.2 standard for unvented heaters. State and local codes in some areas prohibit the use of vent-free heaters. Non-thermostat models may also be operated as a vented decorative (ANSI Z21.60) product by opening flue damper.

SAFETY PILOT

This heater has a pilot with an Oxygen Depletion Sensing (ODS) safety shutoff system. The ODS/pilot is a required feature for vent-free room heaters. The ODS/pilot shuts off the heater if there is not enough fresh air.

PIEZO IGNITION SYSTEM

This heater has a piezo ignitor. This system requires no matches, batteries, or other sources to light heater.

AIR FOR COMBUSTION AND VENTILATION

⚠ WARNING: This heater shall not be installed in a confined space or unusually tight construction unless provisions are provided for adequate combustion and ventilation air. Read the following instructions to insure proper fresh air for this and other fuel-burning appliances in your home.

Today's homes are built more energy efficient than ever. New materials, increased insulation, and new construction methods help reduce heat loss in homes. Home owners weather strip and caulk around windows and doors to keep the cold air out and the warm air in. During heating months, home owners want their homes as airtight as possible.

While it is good to make your home energy efficient, your home needs to breathe. Fresh air must enter your home. All fuel-burning appliances need fresh air for proper combustion and ventilation.

Exhaust fans, fireplaces, clothes dryers, and fuel burning appliances draw air from the house to operate. You must provide adequate fresh air for these appliances. This will insure proper venting of vented fuel-burning appliances.

PROVIDING ADEQUATE VENTILATION

The following are excerpts from *National Fuel Gas Code, ANSI Z223.1/NFPA 54, Section 5.3, Air for Combustion and Ventilation*.

All spaces in homes fall into one of the three following ventilation classifications:

1. Unusually Tight Construction
2. Unconfined Space
3. Confined Space

The information on pages 4 through 6 will help you classify your space and provide adequate ventilation.

Unusually Tight Construction

The air that leaks around doors and windows may provide enough fresh air for combustion and ventilation. However, in buildings of unusually tight construction, you must provide additional fresh air.

Unusually tight construction is defined as construction where:

- a. walls and ceilings exposed to the outside atmosphere have a continuous water vapor retarder with a rating of one perm (6×10^{-11} kg per pa-sec-m²) or less with openings gasketed or sealed and
- b. weather stripping has been added on openable windows and doors and

AIR FOR COMBUSTION AND VENTILATION

Continued

- c. caulking or sealants are applied to areas such as joints around window and door frames, between sole plates and floors, between wall-ceiling joints, between wall panels, at penetrations for plumbing, electrical, and gas lines, and at other openings.

If your home meets all of the three criteria above, you must provide additional fresh air. See *Ventilation Air From Outdoors*, page 6.

If your home does not meet all of the three criteria above, proceed to *Determining Fresh-Air Flow for Heater Location*.

Confined and Unconfined Space

The *National Fuel Gas Code, ANSI Z223.1/NFPA 54* defines a confined space as a space whose volume is less than 50 cubic feet per 1,000 Btu per hour (4.8 m³ per kw) of the aggregate input rating of all appliances installed in that space and an unconfined space as a space whose volume is not less than 50 cubic feet per 1,000 Btu per hour (4.8 m³ per kw) of the aggregate input rating of all appliances installed in that space. Rooms communicating directly with the space in which the appliances are installed*, through openings not furnished with doors, are considered a part of the unconfined space.

* Adjoining rooms are communicating only if there are doorless passageways or ventilation grills between them.

DETERMINING FRESH-AIR FLOW FOR HEATER LOCATION

Determining if You Have a Confined or Unconfined Space

Use this work sheet to determine if you have a confined or unconfined space.

Space: Includes the room in which you will install heater plus any adjoining rooms with doorless passageways or ventilation grills between the rooms.

- Determine the volume of the space (length x width x height).
 $\text{Length} \times \text{Width} \times \text{Height} = \text{_____ cu. ft. (volume of space)}$
Example: Space size 20 ft. (length) x 16 ft. (width) x 8 ft. (ceiling height) = 2560 cu. ft. (volume of space)
 If additional ventilation to adjoining room is supplied with grills or openings, add the volume of these rooms to the total volume of the space.
- Multiply the space volume by 20 to determine the maximum Btu/Hr the space can support.
 $\text{_____ (volume of space)} \times 20 = \text{(Maximum Btu/Hr the space can support)}$
Example: 2560 cu. ft. (volume of space) x 20 = 51,200 (maximum Btu/Hr the space can support)

- Add the Btu/Hr of all fuel burning appliances in the space.

Vent-free heater	_____	Btu/Hr
Gas water heater*	_____	Btu/Hr
Gas furnace	_____	Btu/Hr
Vented gas heater	_____	Btu/Hr
Gas fireplace logs	_____	Btu/Hr
Other gas appliances* +	_____	Btu/Hr
Total	= _____	Btu/Hr

* Do not include direct-vent gas appliances. Direct-vent draws combustion air from the outdoors and vents to the outdoors.

Example:

Gas water heater	_____	40,000	Btu/Hr	
Vent-free heater	+	_____	39,000	Btu/Hr
Total	= _____	79,000	Btu/Hr	

- Compare the maximum Btu/Hr the space can support with the actual amount of Btu/Hr used.

_____ Btu/Hr (maximum the space can support)
 _____ Btu/Hr (actual amount of Btu/Hr used)

Example: 51,200 Btu/Hr (maximum the space can support)
 79,000 Btu/Hr (actual amount of Btu/Hr used)

The space in the above example is a confined space because the actual Btu/Hr used is more than the maximum Btu/Hr the space can support. You must provide additional fresh air. Your options are as follows:

- Rework worksheet, adding the space of an adjoining room. If the extra space provides an unconfined space, remove door to adjoining room or add ventilation grills between rooms. See *Ventilation Air From Inside Building*, page 6.
- Vent room directly to the outdoors. See *Ventilation Air From Outdoors*, page 6.
- Install a lower Btu/Hr heater, if lower Btu/Hr size makes room unconfined.

If the actual Btu/Hr used is less than the maximum Btu/Hr the space can support, the space is an unconfined space. You will need no additional fresh air ventilation.

⚠ WARNING: If the area in which the heater may be operated is smaller than that defined as an unconfined space or if the building is of unusually tight construction, provide adequate combustion and ventilation air by one of the methods described in the *National Fuel Gas Code, ANSI Z223.1/NFPA 54, Section 5.3* or applicable local codes.

AIR FOR COMBUSTION AND VENTILATION

Continued

VENTILATION AIR

Ventilation Air From Inside Building

This fresh air would come from an adjoining unconfined space. When ventilating to an adjoining unconfined space, you must provide two permanent openings: one within 12" of the ceiling and one within 12" of the floor on the wall connecting the two spaces (see options 1 and 2, Figure 3). You can also remove door into adjoining room (see option 3, Figure 3). Follow the *National Fuel Gas Code, ANSI Z223.1/NFPA 54, Section 5.3, Air for Combustion and Ventilation* for required size of ventilation grills or ducts.

Ventilation Air From Outdoors

Provide extra fresh air by using ventilation grills or ducts. You must provide two permanent openings: one within 12" of the ceiling and one within 12" of the floor. Connect these items directly to the outdoors or spaces open to the outdoors. These spaces include attics and crawl spaces. Follow the *National Fuel Gas Code, ANSI Z223.1/NFPA 54, Section 5.3, Air for Combustion and Ventilation* for required size of ventilation grills or ducts.

IMPORTANT: Do not provide openings for inlet or outlet air into attic if attic has a thermostat-controlled power vent. Heated air entering the attic will activate the power vent.

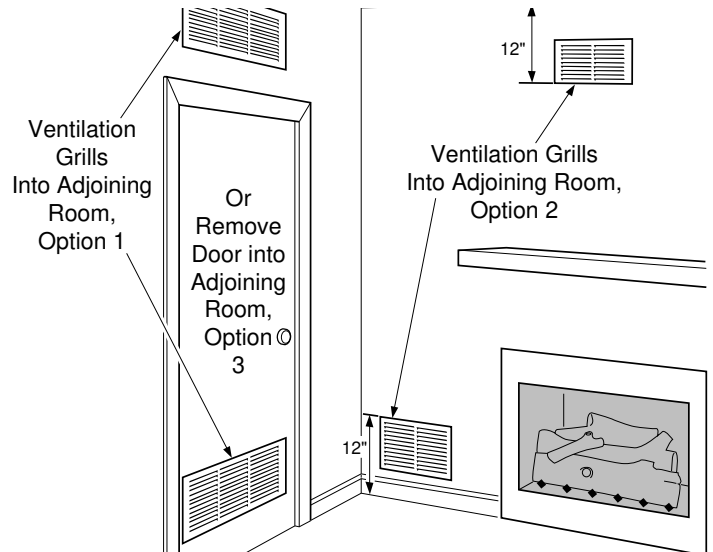

Figure 3 - Ventilation Air from Inside Building

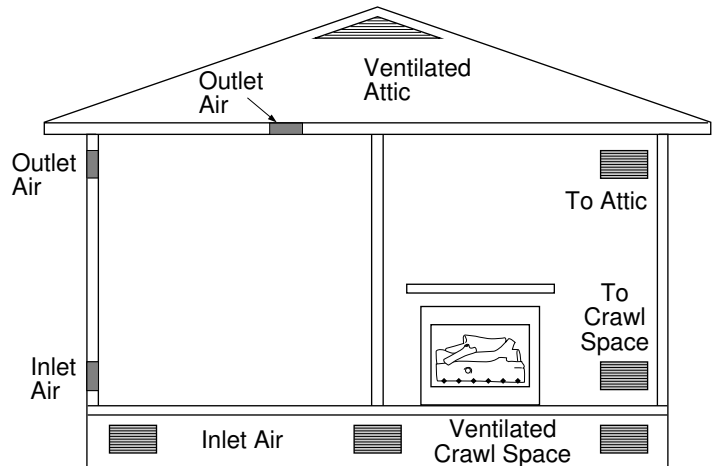

Figure 4 - Ventilation Air from Outdoors

INSTALLATION

NOTICE: This heater is intended for use as supplemental heat. Use this heater along with your primary heating system. Do not install this heater as your primary heat source. If you have a central heating system, you may run system's circulating blower while using heater. This will help circulate the heat throughout the house. In the event of a power outage, you can use this heater as your primary heat source.

⚠ WARNING: A qualified service person must install heater. Follow all local codes.

NOTICE: State or local codes may only allow operation of this appliance in a vented configuration. Check your state or local codes.

⚠ WARNING: Before installing in a solid fuel burning fireplace, the chimney flue and firebox must be cleaned of soot, creosote, ashes, and loose paint by a qualified chimney cleaner. Creosote will ignite if highly heated. A dirty chimney flue may create and distribute soot within the house. Inspect chimney flue and firebox for damage. If damaged, operate heater with flue damper closed.

⚠ WARNING: Seal any fresh air vents or ash clean-out doors located on floor or wall of fireplace. If not, drafting may cause pilot outage or sooting. Use a heat-resistant sealant. Do not seal chimney flue damper.

⚠ WARNING: Never install the heater

- in a bedroom or bathroom unless installed as a vented appliance (Variable Manually-Controlled Models Only) (see page 10)
- in a recreational vehicle
- where curtains, furniture, clothing, or other flammable objects are less than 42 inches from the front, top, or sides of the heater
- in high traffic areas
- in windy or drafty areas

⚠ CAUTION: This heater creates warm air currents. These currents move heat to wall surfaces next to heater. Installing heater next to vinyl or cloth wall coverings or operating heater where impurities (such as, but not limited to, tobacco smoke, aromatic candles, cleaning fluids, oil or kerosene lamps, etc) in the air exist, may discolor walls or cause odors.

IMPORTANT: Vent-free heaters add moisture to the air. Although this is beneficial, installing heater in rooms without enough ventilation air may cause mildew to form from too much moisture. See *Air for Combustion and Ventilation*, pages 4 through 6.

CHECK GAS TYPE

Use only natural gas. If your gas supply is not natural gas, do not install heater. Call dealer where you bought heater for proper type heater.

INSTALLATION AND CLEARANCES (Vent-Free Operation Only)

⚠ WARNING: Maintain the minimum clearances. If you can, provide greater clearances from floor, ceiling, and adjoining wall.

Log Size	Side Wall	Ceiling
18", 24", 30"	16"	42"

Log Size	Minimum Firebox Size			
	Height	Depth	Front Width	Rear* Width
18"	17"	14"	24"	20"
24"	17"	14"	28"	21"
30"	17"	14"	34"	24"

*Measured at 14" Depth

Carefully follow the instructions starting on page 8. This will ensure safe installation into a masonry, UL127-listed manufactured fireplace, or certified vent-free firebox.

INSTALLATION

Continued

Minimum Clearances For Side Combustible Material, Side Wall, and Ceiling

- A. Clearances from the side of the fireplace cabinet to any combustible material and wall should follow diagram in Figure 5.

Example: The face of a mantel, bookshelf, etc. is made of combustible material and protrudes 3 1/2" from the wall. This combustible material must be 4" from the side of the fireplace opening (see Figure 5).

Note: When installing your gas logs into a manufactured firebox, follow firebox manufacturer's instructions for minimum clearances to combustible materials.

- B. Clearances from the top of the fireplace opening to the ceiling should not be less than 42 inches.

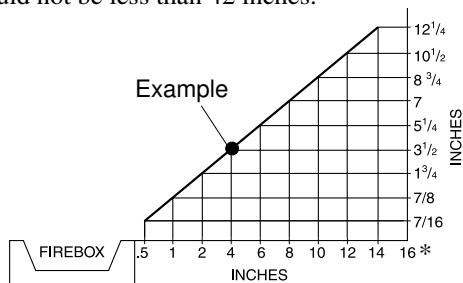

*Minimum 16 inches from Side Wall

Figure 5 - Minimum Clearance for Combustible to Wall

NOTICE: Manual control heaters may be used as a vented product. If so, you must always run heater with chimney flue damper open. If running heater with damper open, noncombustible material above fireplace opening is not needed. Go to *Installing Damper Clamp Accessory for Vented Operation*, page 10.

Minimum Noncombustible Material Clearances

If Not Using Mantel

Note: If using a mantel, proceed to *If Using Mantel*. If not using a mantel, follow the information below.

You must have noncombustible material(s) above the fireplace opening. Noncombustible materials (such as slate, marble, tile, etc.) must be at least 1/2 inch thick. With sheet metal, you must have noncombustible material behind it. Noncombustible material must extend at least 8" up (for all models). If noncombustible material is less than 12", you must install the fireplace hood accessory (24" and 30" models only). See Figure 6 for minimum clearances.

IMPORTANT: If you cannot meet these minimum clearances, you must operate heater with chimney flue damper open. Go to *Installing Damper Clamp Accessory for Vented Operation*, page 10.

If Using Mantel

You must have noncombustible material(s) above the fireplace opening. Noncombustible materials (such as slate, marble, tile, etc.) must be at least 1/2 inch thick. With sheet metal, you must have noncombustible material behind it. Noncombustible material must extend at least 8 inches up (for all models). If noncombustible material is less than 12", you must install the fireplace hood accessory (24" and 30" models only). Even if noncombustible material is more than 12", you may need the hood accessory to deflect heat away from your mantel shelf. See Figure 6 and Figures 7 and 8 on page 9 for minimum clearances.

IMPORTANT: If you cannot meet these minimum clearances, you must operate heater with chimney flue damper open. Go to *Installing Damper Clamp Accessory for Vented Operation*, page 10.

Noncombustible Material Distance (A)	Requirements for Safe Installation
12" or more	Noncombustible material okay.
Between 8" and 12"	24" or 30" Models: Install fireplace hood accessory (GA6050, GA6052, or GA6053 see <i>Accessories</i> , page 36). 18" Model: Noncombustible material okay.
Less than 8"	Noncombustible material must be extended to at least 8". See <i>Between 8" and 12"</i> , above. If you cannot extend material, you must operate heater with flue damper open.

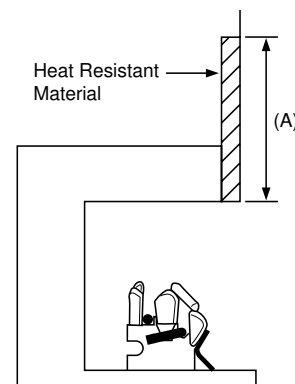

Figure 6 - Heat Resistant Material (Slate, Marble, Tile, etc.) Above Fireplace

INSTALLATION

Continued

MANTEL CLEARANCES

In addition to meeting noncombustible material clearances, you must also meet required clearances between fireplace opening and mantel shelf. If you do not meet the clearances listed in Figure 7, you will need a hood.

Determining Minimum Mantel Clearance

If you meet minimum clearance between mantel shelf and top of fireplace opening, a hood is not required (see Figure 7).

Determining Minimum Mantel Clearance When Using a Hood

If minimum clearances in Figure 7 are not met, you must have a hood. When using a hood there are still certain minimum mantel clearances required. Follow minimum clearances shown in Figure 8 when using hood.

NOTICE: Surface temperatures of adjacent walls and mantels become hot during operation. Walls and mantels above the firebox may become hot to the touch. If installed properly, these temperatures meet the requirement of the national product standard. Follow all minimum clearances shown in this manual.

NOTICE: If your installation does not meet the minimum clearances shown, you must do one of the following:

- operate the logs only with the flue damper open
- raise the mantel to an acceptable height
- remove the mantel

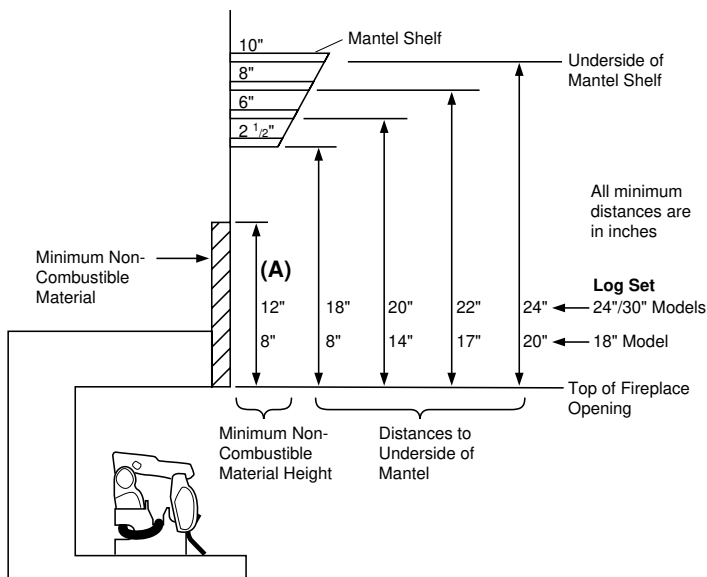

Figure 7 - Minimum Mantel Clearances Without Using Hood

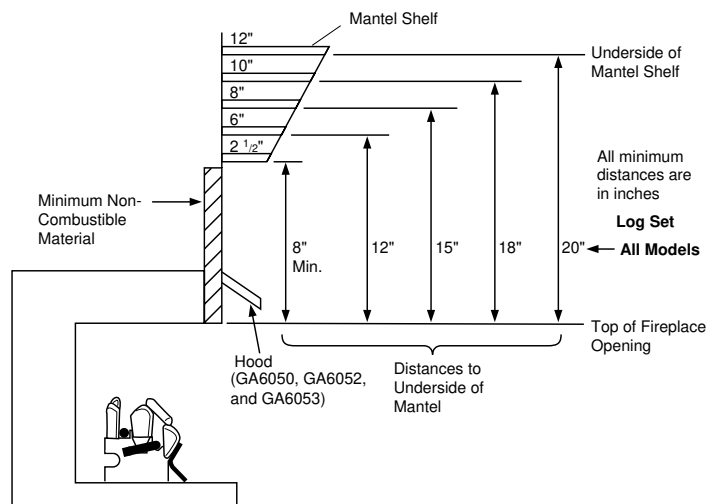

Figure 8 - Minimum Mantel Clearances When Using Hood

FLOOR CLEARANCES

- A. If installing appliance on the floor level, you must maintain the minimum distance of 14" to combustibles (see Figure 9).
- B. If combustible materials are less than 14" to the fireplace, you must install appliance at least 5" above the combustible flooring (see Figure 10).

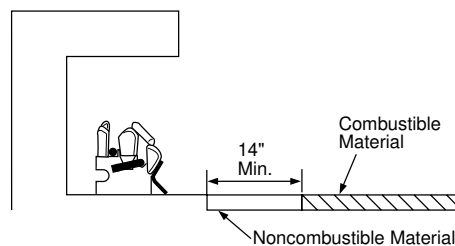

Figure 9 - Minimum Fireplace Clearances If Installed at Floor Level

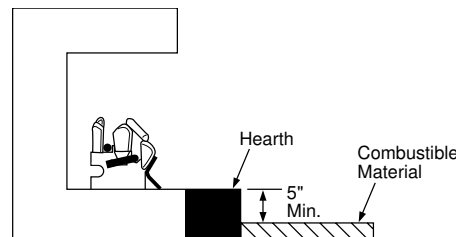

Figure 10 - Minimum Fireplace Clearances Above Combustible Flooring

INSTALLATION

Continued

INSTALLING DAMPER CLAMP ACCESSORY FOR VENTED OPERATION

Note: When used as a vented heater, appliance must be installed only in a solid-fuel burning fireplace with a working flue and constructed of noncombustible material.

If your heater is a manually-controlled model, you may use this heater as a vented product. There are three reasons for operating your heater in the vented mode.

1. The fireplace does not meet the clearance to combustibles requirements for vent-free operation.
2. State or local codes do not permit vent-free operation.
3. You prefer vented operation.

If reasons number 1 or 2 above apply to you, you must permanently open chimney flue damper. You must install the damper clamp accessory (to order, see *Accessories*, page 36). This will insure vented operation (see Figure 11). The damper clamp will keep damper open. Installation instructions are included with clamp accessory.

See charts in column 2 for minimum permanent flue opening you must provide. Attach damper clamp so the minimum permanent flue opening will be maintained at all times.

Area of Various Standard Round Flues	
Diameter (ins.)	Area (sq. ins.)
5"	20 sq. inches
6"	29 sq. inches
7"	39 sq. inches
8"	51 sq. inches

Chimney Height (ft.)	Minimum Permanent Flue Opening (sq. ins.)
6' to 15'	39 sq. inches
15' to 30'	29 sq. inches

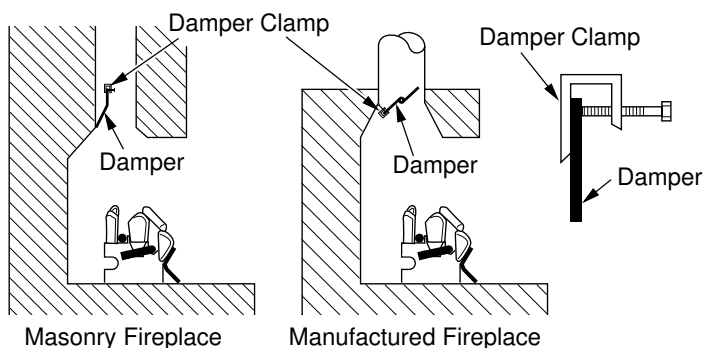

Figure 11 - Attaching Damper Clamp

INSTALLING HEATER BASE ASSEMBLY

CAUTION: Do not remove the data plates attached to the heater base assembly. The data plates contain important warranty and safety information.

WARNING: You must secure this heater to fireplace floor. If not, heater will move when you adjust controls. Moving heater may cause a gas leak or log misplacement.

WARNING: If installing in a sunken fireplace, special care is needed. You must raise the fireplace floor to allow access to heater control panel. This will insure adequate air flow and guard against sooting and controls from being damaged. Raise fireplace floor with noncombustible material. Make sure material is secure.

CAUTION: Do not pick up heater base assembly by the burner. This could damage heater. Only handle base assembly by grates.

IMPORTANT: Make sure the heater burners are level. If heater is not level, heater will not work properly. For thermostat models, avoid damage to thermostat bulb. Avoid nicks or sharp bends in thermostat bulb wire. Keep thermostat bulb in mounting bracket until ready to mount base to floor. See *Optional Positioning Of Thermostat Sensing Bulb*, page 25.

Installation Items Needed

- hardware package (provided with heater)
- approved flexible gas hose (not provided) (if allowed by local codes)
- sealant resistant to propane (propane/LP) gas, not provided
- electric drill with 3/16" drill bit
- flathead screwdriver

INSTALLATION

Continued

1. Apply pipe joint sealant lightly to male threads of the fitting to be threaded into gas regulator. Connect approved flexible gas hose to gas regulator of heater (see Figure 12).

IMPORTANT: Hold gas regulator with wrench when connecting flexible gas hose.

2. Locate masonry screws in hardware package.
3. Position heater base assembly in fireplace.
4. Place logs in their proper position on heater base, see *Installing Logs* on pages 13 through 16.
5. Center heater base and logs front-to-back and side-to-side in fireplace.
6. Carefully remove logs without moving heater base.
7. Mark screw locations through holes in mounting brackets (see Figure 13 or 14). If installing in a brick-bottom fireplace, mark screw locations in mortar joint of bricks.
8. Remove heater base from fireplace.
9. Drill holes at marked locations using 3/16" drill bit.
10. Attach base assembly to fireplace floor using two masonry screws (in hardware package) (see Figures 13 or 14).

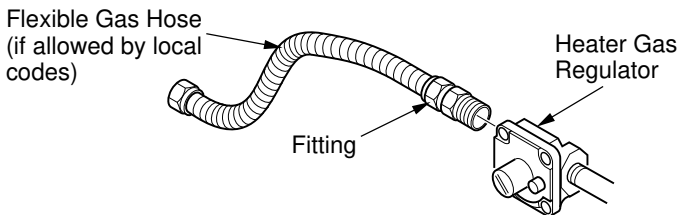

Figure 12 - Attaching Flexible Gas Hose to Heater Gas Regulator

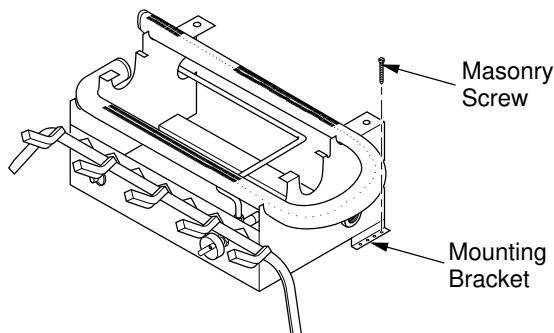

Figure 13 - Attaching Base Assembly to Fireplace Floor - Dual Burner Model

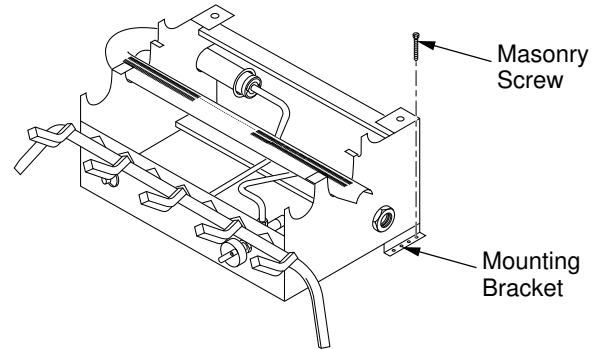

Figure 14 - Attaching Base Assembly to Fireplace Floor - Single Burner Model

CONNECTING TO GAS SUPPLY

⚠ WARNING: This appliance requires a 1/2" NPT (National Pipe Thread) inlet connection to the pressure regulator.

⚠ WARNING: A qualified service person must connect heater to gas supply. Follow all local codes.

Installation Items Needed

Before installing heater, make sure you have the items listed below.

- piping (check local codes)
- sealant (resistant to propane/LP gas)
- equipment shutoff valve *
- test gauge connection *
- sediment trap
- tee joint
- pipe wrench

* A CSA design-certified equipment shutoff valve with 1/8" NPT tap is an acceptable alternative to test gauge connection. Purchase the optional CSA design-certified equipment shutoff valve from your dealer. See *Accessories*, page 36.

⚠ WARNING: Never connect heater to private (non-utility) gas wells. This gas is commonly known as wellhead gas.

⚠ CAUTION: Use only new, black iron or steel pipe. Internally-tinned copper tubing may be used in certain areas. Check your local codes. Use pipe of 1/2" diameter or greater to allow proper gas volume to heater. If pipe is too small, undue loss of volume will occur.

INSTALLATION

Continued

Installation must include an equipment shutoff valve, union, and plugged 1/8" NPT tap. Locate NPT tap within reach for test gauge hook up. NPT tap must be upstream from heater (see Figure 15).

IMPORTANT: Install equipment shutoff valve in an accessible location. The equipment valve is for turning on or shutting off the gas to the appliance.

Check your building codes for any special requirements for locating equipment shutoff valve to fireplaces.

Apply pipe joint sealant lightly to male NPT threads. This will prevent excess sealant from going into pipe. Excess sealant in pipe could result in clogged heater valves.

⚠ WARNING: Use pipe joint sealant that is resistant to liquid petroleum (LP) gas.

We recommend that you install a sediment trap in supply line as shown in Figure 15. Locate sediment trap where it is within reach for cleaning. Install in piping system between fuel supply and heater. Locate sediment trap where trapped matter is not likely to freeze. A sediment trap traps moisture and contaminants. This keeps them from going into heater controls. If sediment trap is not installed or is installed wrong, heater may not run properly.

⚠ CAUTION: Avoid damage to regulator. Hold gas regulator with wrench when connecting it to gas piping and/or fittings.

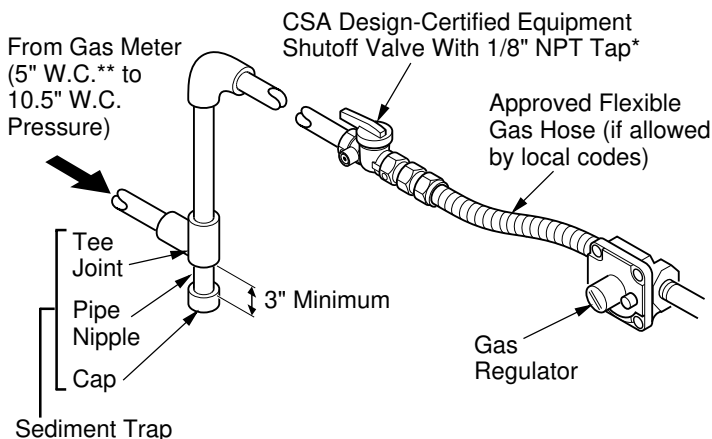

Figure 15 - Gas Connection

* Purchase the optional CSA design-certified equipment shutoff valve from your dealer. See *Accessories*, page 36.

** Minimum inlet pressure for purpose of input adjustment.

CHECKING GAS CONNECTIONS

⚠ WARNING: Test all gas piping and connections for leaks after installing or servicing. Correct all leaks at once.

⚠ WARNING: Never use an open flame to check for a leak. Apply a noncorrosive leak detection fluid to all joints. Bubbles forming show a leak. Correct all leaks at once.

Pressure Testing Gas Supply Piping system

Test Pressures In Excess Of 1/2 PSIG (3.5 kPa)

1. Disconnect appliance with its appliance main gas valve (control valve) and equipment shutoff valve from gas supply piping system. Pressures in excess of 1/2 psig will damage heater regulator.
2. Cap off open end of gas pipe where equipment shutoff valve was connected.
3. Pressurize supply piping system by either using compressed air or opening main gas valve located on or near gas meter.
4. Check all joints of gas supply piping system. Apply a noncorrosive leak detection fluid to gas joints. Bubbles forming show a leak.
5. Correct all leaks at once.
6. Reconnect heater and equipment shutoff valve to gas supply. Check reconnected fittings for leaks.

Test Pressures Equal To or Less Than 1/2 PSIG (3.5 kPa)

1. Close equipment shutoff valve (see Figure 16).
2. Pressurize supply piping system by either using compressed air or opening main gas valve located on or near gas meter.
3. Check all joints from gas meter to equipment shutoff valve (see Figure 17, page 13). Apply a noncorrosive leak detection fluid to gas joints. Bubbles forming show a leak.
4. Correct all leaks at once.

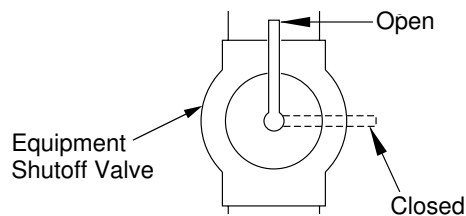

Figure 16 - Equipment Shutoff Valve

INSTALLATION

Continued

Pressure Testing Heater Gas Connections

1. Open equipment shutoff valve (see Figure 16, page 12).
2. Open main gas valve located on or near gas meter.
3. Make sure control knob of heater is in the OFF position.
4. Check all joints from equipment shutoff valve to control valve (see Figure 17). Apply a noncorrosive leak detection fluid to gas joints. Bubbles forming show a leak.
5. Correct all leaks at once.
6. Light heater (see *Operating Heater*, pages 17 and 18 [manually-controlled models] or pages 18 through 20 [thermostatically-controlled models]). Check all other internal joints for leaks.
7. Turn off heater (see *To Turn Off Gas to Appliance*, page 18 [manually-controlled models] or page 19 [thermostatically-controlled models]).

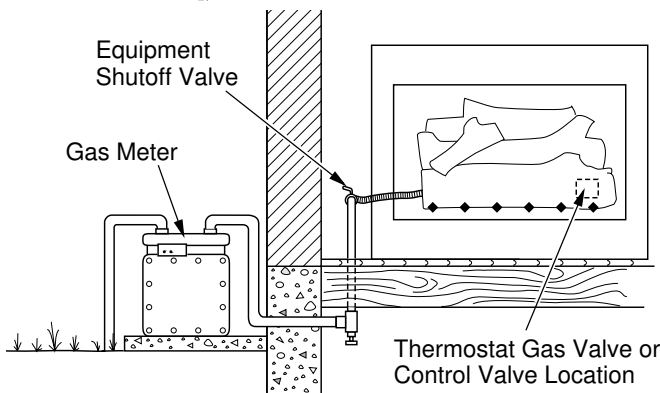

Figure 17 - Checking Gas Joints

INSTALLING LOGS

CAUTION: After installation and periodically thereafter, check to ensure that no flame comes in contact with any log. With the heater set to high, check to see if flames contact any log. If so, reposition logs according to the log installation instructions in this manual. Flames contacting logs will create soot.

Dual Burner Smoky Mountain Oak Models

WARNING: Failure to position the parts in accordance with these diagrams or failure to use only parts specifically approved with this heater may result in property damage or personal injury.

Each log is marked with a number. These numbers will help you identify the log when installing. It is very important to install these logs exactly as instructed. Do not modify logs. Only use logs supplied with heater.

1. Locate pins on the bottom of back log (#1). Slide these pins into the holes in the grate base behind the burner (see Figure 18).
2. Place the base of the middle log (#2) in the U-shaped slots of the grate base in front of the back log. The cutout on the right of the middle log should fit over the burner (see Figure 19). Make sure the front of the middle log is resting on the tabs of the grate base and the cutout area is centered over the burner "U" bend.
3. Locate the recesses on the back of the front log (#3). Fit these recesses between the posts of the grate base (see Figure 20).
4. Locate the notches in the bottom of the crossover log (#4). Place the crossover log on top of the middle log and front log. Make sure the notches of the crossover log lines up with rectangular knobs on top of the middle and front logs (see Figure 21).
5. Place lava rock around base of heater if desired. Do not put lava rock on logs on burner.

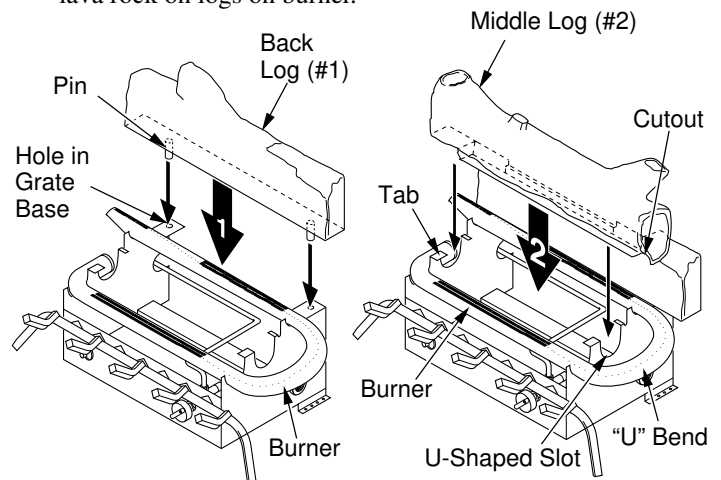

Figure 18 - Installing Back Log (#1)

Figure 19 - Installing Middle Log (#2)

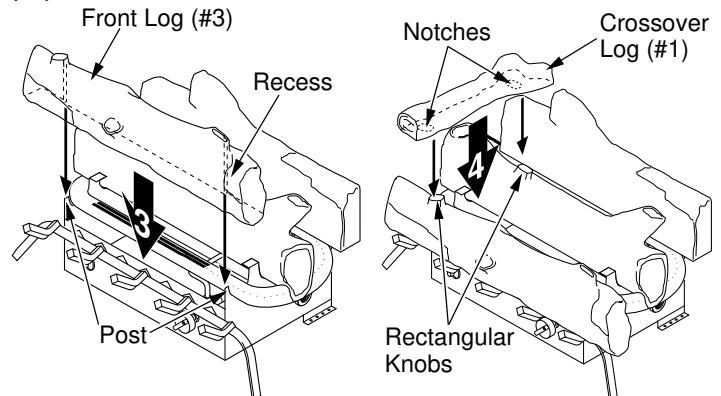

Figure 20 - Installing Front Log (#3)

Figure 21 - Installing Crossover Log (#4)

INSTALLATION

Continued

Dual Burner Premium Aged Split Oak Models

⚠ WARNING: Failure to position the parts in accordance with these diagrams or failure to use only parts specifically approved with this heater may result in property damage or personal injury.

Each log is marked with a number. These numbers will help you identify the log when installing. It is very important to install these logs exactly as instructed. Do not modify logs. Only use logs supplied with heater.

1. Place the base of the middle log (#1) in the U-shaped slots of the grate base. The cutout on the right of the middle log should fit over the burner (see Figure 22). Make sure the front of the middle log is resting on the tabs of the grate base and the cut-out area is centered over the burner "U" bend.
2. Locate pins on the bottom of back log (#2). Slide these pins into the holes in the grate base behind the burner (see Figure 23).
3. Place crossover log (#3) onto the pin (right) on middle log (#1) and into the recess of the back log (#2). See Figure 24.
4. Locate the notches in the bottom of the front log (#4). Place the front log on the grate fingers. Make sure the notches of the front log line up with the grate fingers. See Figure 25.
5. With knot to right side, place smaller log piece (#5) over the pin on the left side of the middle log. The smaller log will rest on front log against the "knot" on the left. See Figure 26.
6. Place lava rock around base of heater if desired. Do not put lava rock on logs on burner.

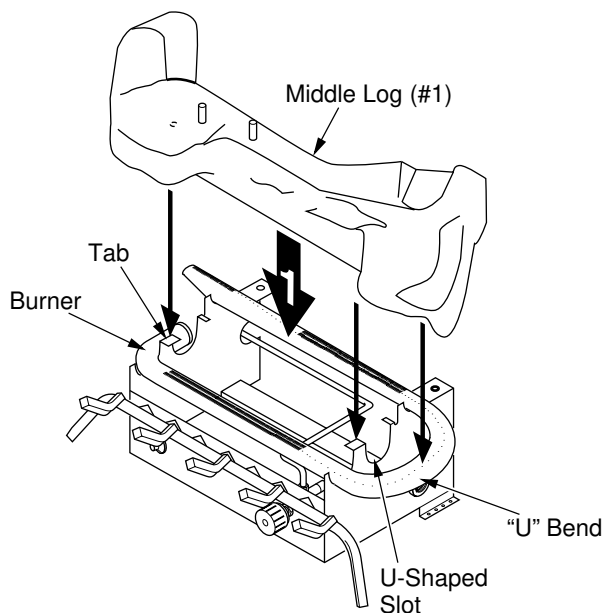

Figure 22 - Installing Middle Log (#1)

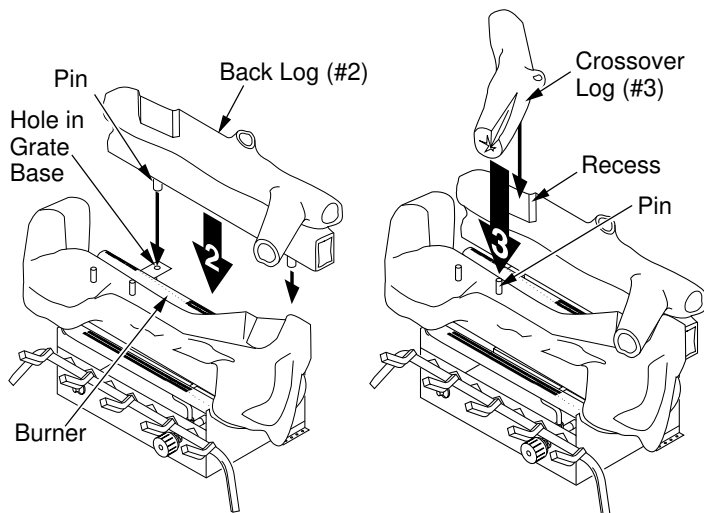

Figure 23 - Installing Back Log (#2)

Figure 24 - Installing Crossover Log (#3)

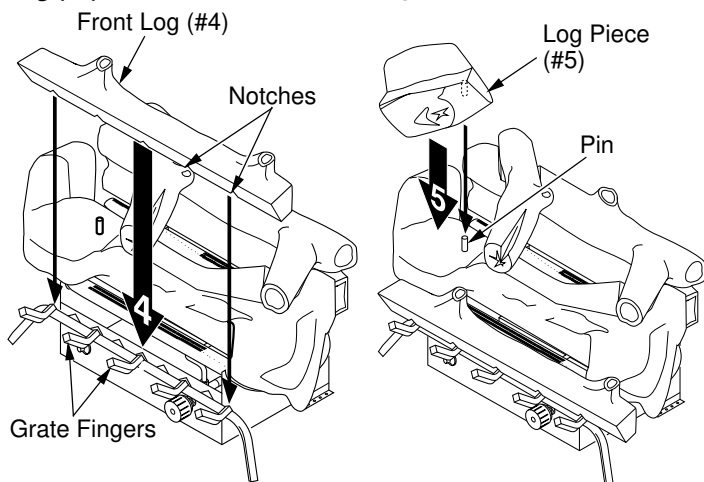

Figure 25 - Installing Front Log (#4)

Figure 26 - Installing Log Piece (#5)

Dual Burner Biltmore Split Oak Models

⚠ WARNING: Failure to position the parts in accordance with these diagrams or failure to use only parts specifically approved with this heater may result in property damage or personal injury.

⚠ CAUTION: After installation and periodically thereafter, check to ensure that no flame comes in contact with any log. With the heater set to HI, check to see if flames contact any log. If so, reposition logs according to the log installation instructions in this manual. Flames contacting logs will create soot.

INSTALLATION

Continued

Each log is marked with a number. These numbers will help you identify the log when installing. It is very important to install these logs exactly as instructed. Do not modify logs. Only use logs supplied with heater.

1. Place the front log (#1) on the grate fingers. Make sure the front log rests firmly between the grate fingers and the grate base (see Figure 27).
2. Place the base of the middle log (#2) in the U-shaped slots of the grate base. The cutout on the right of the middle log should fit over the burner (see Figure 28). Make sure the front of the middle log is resting on the tabs of the grate base.
3. Locate pins on the bottom of back log (#3). Slide these pins into the holes in the grate base behind the burner (see Figure 29).
4. Locate holes on the bottom of crossover log (#4). Slide front hole onto the left pin (CCL3924NT or CCL3930NTA) or middle pin (CCL3018NT or CCL3018N) on the middle log (#2) and the pin on the back log (#3). See Figure 30 for placement.
5. **For CCL3924NT and CCL3930NTA Only:** Locate pin and hole on the bottom of crossover log (#5). Slide the pin into the hole located in crossover log (#4). Slide the hole onto the pin on front log (#1). See Figure 31.
6. **For CCL3018NT and CCL3018N Only:** Locate holes on the bottom of crossover log (#5). Slide the holes over the left pins on middle log (#2) and front log (#1). See Figure 32.
7. **For CCL3930NTA only:** Locate holes on the bottom of crossover log (#7). Slide onto the pins located in crossover log (#6) and middle log (#2). See Figure 34.
8. Add lava rock around base of heater if desired. Do not place any lava rock on logs or burner.

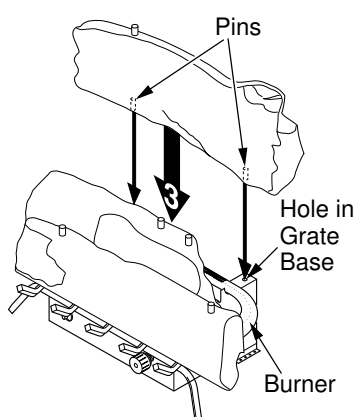

Figure 29 - Installing Rear Log (#3) (CCL3930NTA Shown)

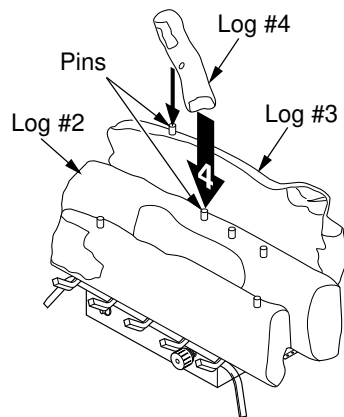

Figure 30 - Installing Crossover Log (#4) (CCL3930NTA Shown)

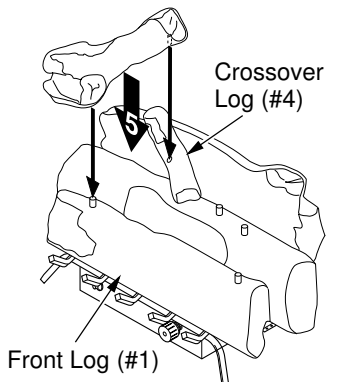

Figure 31 - Installing Crossover Log (#5) (CCL3930NTA Shown)

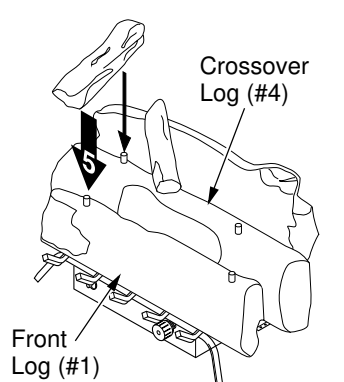

Figure 32 - Installing Crossover Log (#5) (CCL3018NT and CCL3018N Only)

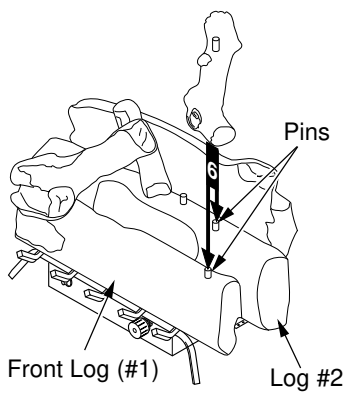

Figure 33 - Installing Crossover Log (#6) (CCL3930NTA Shown)

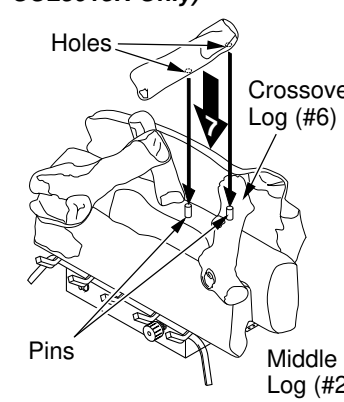

Figure 34 - Installing Crossover Log (#7) to Model CCL3930NTA Only

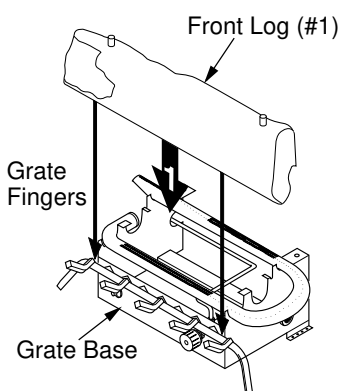

Figure 27 - Installing Front Log (#1) (CCL3930NTA Shown)

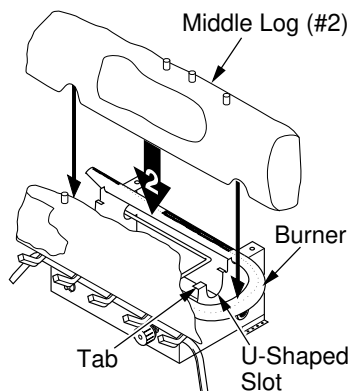

Figure 28 - Installing Middle Log (#2) (CCL3930NTA Shown)

INSTALLATION

Continued

Single Burner Seasonal Oak Models

⚠ WARNING: Failure to position the parts in accordance with these diagrams or failure to use only parts specifically approved with this heater may result in property damage or personal injury.

The Seasonal Oak Log Set is a reversible log set. This means that the two bottom logs may be turned to face either direction. The top log, however, must remain in the same position. Do not modify logs. Only use logs supplied with heater.

1. Place the back log onto the back of the base assembly. Make sure log sits forward against the two posts in front of log (see Figure 35). This log may be turned to face either direction.
2. Place the front log onto grate on front of base assembly. The log will fit down between grate fingers and posts on front of base assembly (see Figure 36). This log may be turned to face either direction.
3. Place the crossover log on top of the back log and front log making sure pins are inserted into holes on top of logs 1 and 2. This log must be placed as shown in the Figure 37 or the pins will not seat into holes.
4. Add lava rock around base of heater if desired. Do not put lava rock on logs or burner.

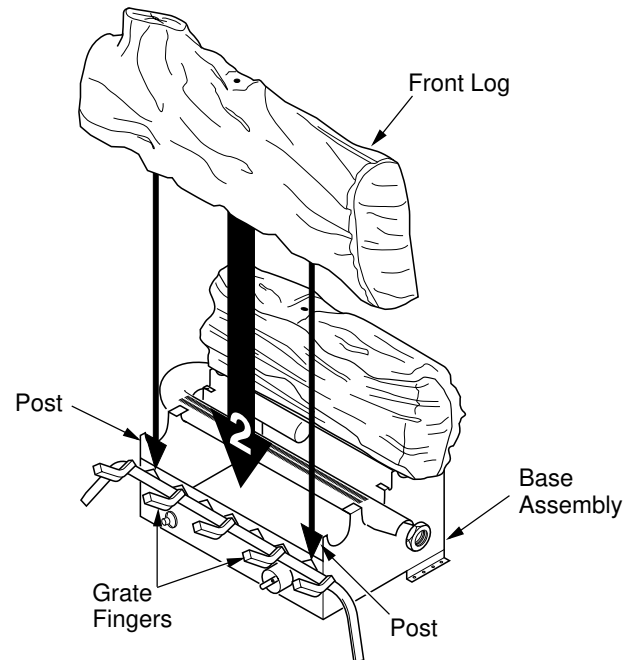

Figure 36 - Installing Front Log

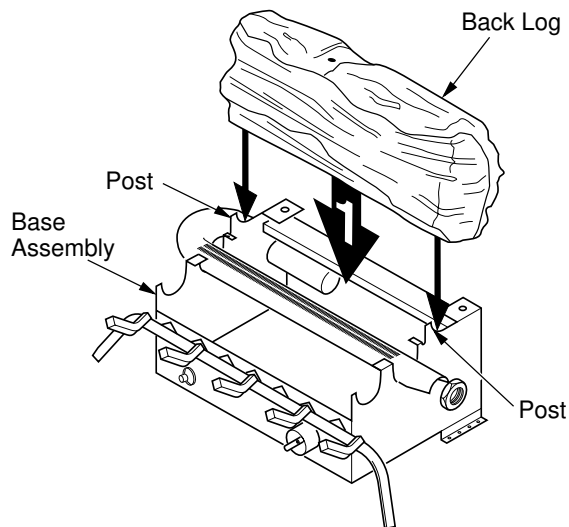

Figure 35 - Installing Back Log

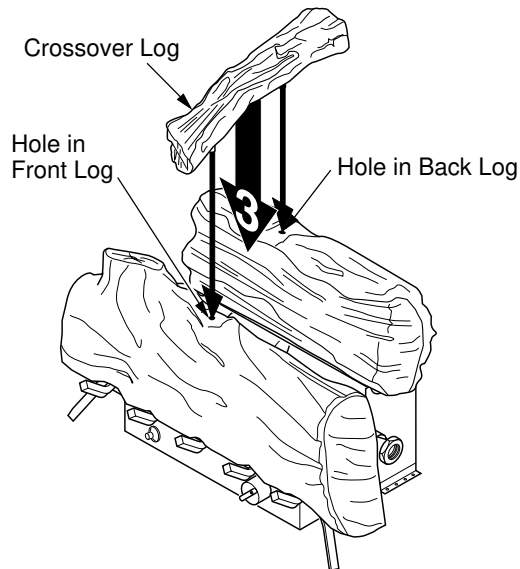

Figure 37 - Installing Crossover Log

OPERATING HEATER

Manually-Controlled Models

FOR YOUR SAFETY READ BEFORE LIGHTING

⚠ WARNING: If you do not follow these instructions exactly, a fire or explosion may result causing property damage, personal injury or loss of life.

- A. This appliance has a pilot which must be lighted by hand. When lighting the pilot, follow these instructions exactly.
- B. **BEFORE LIGHTING** smell all around the appliance area for gas. Be sure to smell next to the floor because some gas is heavier than air and will settle on the floor.

WHAT TO DO IF YOU SMELL GAS

- Do not try to light any appliance.
 - Do not touch any electric switch; do not use any phone in your building.
 - Immediately call your gas supplier from a neighbor's phone. Follow the gas supplier's instructions.
 - If you cannot reach your gas supplier, call the fire department.
- C. Use only your hand to push in or turn the gas control knob. Never use tools. If the knob will not push in or turn by hand, don't try to repair it, call a qualified service technician or gas supplier. Force or attempted repair may result in a fire or explosion.
 - D. Do not use this appliance if any part has been under water. Immediately call a qualified service technician to inspect the appliance and to replace any part of the control system and any gas control which has been under water.

LIGHTING INSTRUCTIONS



⚠ WARNING:

- If fireplace has glass doors, never operate this heater with glass doors closed. If you operate heater with doors closed, heat buildup inside fireplace will cause glass to burst. Also if fireplace opening has vents at the bottom, you must open the vents before operating heater.
- You must operate this heater with a fireplace screen in place. Make sure fireplace screen is closed before running heater.

NOTICE: During initial operation of new heater, burning logs will give off a paper-burning smell. Orange flame will also be present. Open damper or window to vent smell. This will only last a few hours.

Note: Home owners generally prefer to operate their heater with the chimney damper closed. This will put all the heat into the room. However, there may be times you will desire the full flames of the HI heat setting but will find the heat output excessive. You can open the chimney damper (if you have one) fully or partially to release some of the heat.

⚠ WARNING: Damper handle will be hot if heater has been running.

1. **STOP!** Read the safety information in column 1.
2. Make sure equipment shutoff valve is fully open.
3. Press in and turn control knob clockwise  to the OFF position.
4. Wait five (5) minutes to clear out any gas. Then smell for gas, including near the floor. If you smell gas, **STOP!** Follow "B" in the safety information, column 1. If you don't smell gas, go to the next step.
5. Slightly depress and turn control knob counterclockwise  to the PILOT position. Press in control knob for five (5) seconds (see Figure 39).

Note: You may be running this heater for the first time after hooking up to gas supply. If so, the control knob may need to be pressed in for 30 seconds or more. This will allow air to bleed from the gas system.

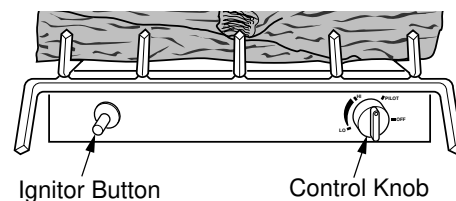

Figure 38 - Control Knob and Ignitor Button Location

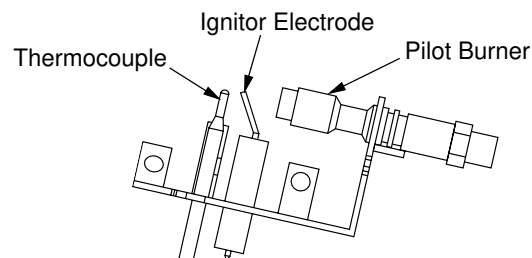

Figure 39 - Pilot

OPERATING HEATER (MANUALLY CONTROLLED MODELS)*Lighting Instructions (Cont.)**Variable Control Operation**To Turn Off Gas To Appliance**Manual Lighting Procedure***OPERATING HEATER (THERMOSTATICALLY-CONTROLLED MODELS)***For Your Safety Read Before Lighting***OPERATING HEATER***Continued*

- With control knob pressed in, press and release ignitor button. This will light pilot. The pilot is attached to the burner. If needed, keep pressing ignitor button until pilot lights.

Note: If pilot does not stay lit, contact a qualified service person or gas supplier for repairs. Until repairs are made, light pilot with match. To light pilot with match, see *Manual Lighting Procedure*.

- Keep control knob pressed in for 30 seconds after lighting pilot. After 30 seconds, release control knob.

Note: If pilot goes out, repeat steps 3 through 7 on page 17. If control knob does not pop out when released, contact a qualified service person or gas supplier for repairs.

- Slightly depress and turn control knob counterclockwise to desired heating level. The burner(s) should light. Set control knob to any heat level between HI and LO.



⚠ WARNING: Do not operate heater between PILOT and HIGH positions.

VARIABLE CONTROL OPERATION



The variable control valve can be set to any heat setting and flame height desired, by simply turning the control knob until that setting is attained. Even the lowest setting provides realistic, dancing yellow flames. Selecting higher settings produces greater heat output. This results in increased heating comfort.

⚠ CAUTION: Do not try to adjust heating levels by using the equipment shutoff valve.

TO TURN OFF GAS TO APPLIANCE**Shutting Off Heater**

- Press in and turn control knob clockwise  to the HI position.
- Turn control knob clockwise  to the pilot position.
- Press in control knob and turn clockwise  to the OFF position.

Shutting Off Burner(s) Only (pilot stays lit)

- Turn control knob clockwise  to the HI position.
- Press in and turn control knob clockwise  to the pilot position.

MANUAL LIGHTING PROCEDURE

- Follow steps 1 through 5 under *Lighting Instructions*, page 17.
- Depress control knob and light pilot with match.
- Keep control knob pressed in for 30 seconds after lighting pilot. After 30 seconds, release control knob. Now follow step 8, column 1.

OPERATING HEATER
Thermostatically-Controlled Models**FOR YOUR SAFETY READ BEFORE LIGHTING**

⚠ WARNING: If you do not follow these instructions exactly, a fire or explosion may result causing property damage, personal injury or loss of life.

- This appliance has a pilot which must be lighted by hand. When lighting the pilot, follow these instructions exactly.
- BEFORE LIGHTING** smell all around the appliance area for gas. Be sure to smell next to the floor because some gas is heavier than air and will settle on the floor.

WHAT TO DO IF YOU SMELL GAS

- Do not try to light any appliance.
 - Do not touch any electric switch; do not use any phone in your building.
 - Immediately call your gas supplier from a neighbor's phone. Follow the gas supplier's instructions.
 - If you cannot reach your gas supplier, call the fire department.
- Use only your hand to push in or turn the gas control knob. Never use tools. If the knob will not push in or turn by hand, don't try to repair it, call a qualified service technician or gas supplier. Force or attempted repair may result in a fire or explosion.
 - Do not use this appliance if any part has been under water. Immediately call a qualified service technician to inspect the appliance and to replace any part of the control system and any gas control which has been under water.

OPERATING HEATER

Continued



**LIGHTING
INSTRUCTIONS****⚠ WARNING:**

- If fireplace has glass doors, never operate this heater with glass doors closed. If you operate heater with doors closed, heat buildup inside fireplace will cause glass to burst. Also if fireplace opening has vents at the bottom, you must open the vents before operating heater.
- You must operate this heater with a fireplace screen in place. Make sure fireplace screen is closed before running heater.

NOTICE: During initial operation of new heater, burning logs will give off a paper-burning smell. Orange flame will also be present. Open damper or window to vent smell. This will only last a few hours.

Note: Home owners generally prefer to operate their heater with the chimney damper closed. This will put all the heat into the room. However, there may be times you will desire the full flames of the HI heat setting but will find the heat output excessive. You can open the chimney damper (if you have one) fully or partially to release some of the heat.

⚠ WARNING: Damper handle will be hot if heater has been running.

1. STOP! Read the safety information in column 2, page 18.
2. Make sure equipment shutoff valve is fully open.
3. Turn control knob clockwise  to the OFF position.
4. Wait five (5) minutes to clear out any gas. Then smell for gas, including near the floor. If you smell gas, STOP! Follow "B" in the safety information in column 2, page 18. If you don't smell gas, go to the next step.
5. Turn control knob counterclockwise  to the PILOT position. Press in control knob for five (5) seconds (see Figure 40).

Note: You may be running this heater for the first time after hooking up to gas supply. If so, the control knob may need to be pressed in for 30 seconds or more. This will allow air to bleed from the gas system.

- If control knob does not pop out when released, contact a qualified service person or gas supplier for repairs.

6. With control knob pressed in, press and release ignitor button. This will light pilot. The pilot is attached to the front burner. If needed, keep pressing ignitor button until pilot lights.

Note: If pilot does not stay lit, contact a qualified service person or gas supplier for repairs. Until repairs are made, light pilot with match. To light pilot with match, see *Manual Lighting Procedure*, page 20.

7. Keep control knob pressed in for 30 seconds after lighting pilot. After 30 seconds, release control knob.

Note: If pilot goes out, repeat steps 3 through 7. This heater has a safety interlock system. Wait one (1) minute for system to reset before lighting pilot again.

8. Turn control knob counterclockwise  to desired heating level. The burners should light. Set control knob to any heat level between HI and LO.

⚠ CAUTION: Do not try to adjust heating levels by using the equipment shutoff valve.

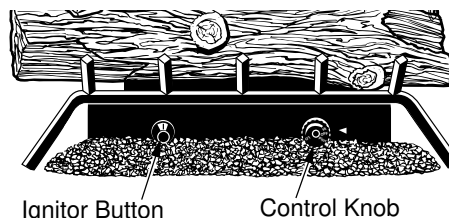

Figure 40 - Control Knob and Ignitor Button Location

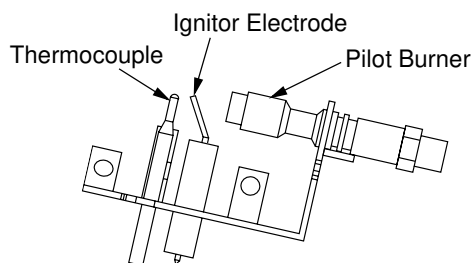



Figure 41 - Pilot

**TO TURN OFF GAS
TO APPLIANCE****Shutting Off Heater**

Turn control knob clockwise  to the OFF position.

Shutting Off Burners Only (pilot stays lit)

Turn control knob clockwise  to the PILOT position.

OPERATING HEATER

Continued

THERMOSTAT CONTROL OPERATION

The thermostat control knob can be set to any comfort level between HI and LO. The thermostat will gradually modulate the heat output and flame height from higher to lower settings, or pilot, in order to maintain the comfort level you select. The ideal comfort setting will vary by household depending upon the amount of space to be heated, the output of the central heating system, etc.

Note: Selecting the HI setting with the control knob will cause the burners to remain fully on, without modulating down in most cases.

MANUAL LIGHTING PROCEDURE

1. Follow steps 1 through 5 under *Lighting Instructions*, page 19.
2. Depress control knob and light pilot with match.
3. Keep control knob pressed in for 30 seconds after lighting pilot. After 30 seconds, release control knob. Now follow step 8 under *Lighting Instructions*, page 19.

INSPECTING BURNERS

Check pilot flame pattern and burner flame patterns often.

PILOT FLAME PATTERN

Figure 42 shows a correct pilot flame pattern. Figure 43 shows an incorrect pilot flame pattern. The incorrect pilot flame is not touching the thermocouple. This will cause the thermocouple to cool. When the thermocouple cools, the heater will shut down.

If pilot flame pattern is incorrect, as shown in Figure 44

- turn heater off (see *To Turn Off Gas to Appliance*, page 18 for manually-controlled models or page 19 for thermostat-controlled models)
- see *Troubleshooting*, pages 22 through 24

Note: The pilot flame on natural gas units will have a slight curve, but flame should be blue and have no yellow or orange color.

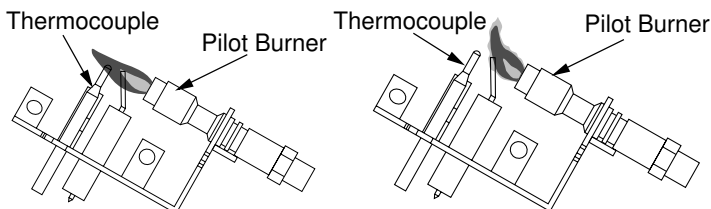

Figure 42 - Correct Pilot Flame Pattern

Figure 43 - Incorrect Pilot Flame Pattern

BURNER PRIMARY AIR HOLES

Air is drawn into the burner through the holes in the fitting at the entrance to the burner. These holes may become blocked with dust or lint. Periodically inspect these holes for any blockage and clean as necessary. Blocked air holes will create soot.

MAIN BURNER

Periodically inspect all burner flame holes with the heater running. All slotted burner flame holes should be open with yellow flame present. All round burner flame holes should be open with a small blue flame present. Some burner flame holes may become blocked by debris or rust, with no flame present. If so, turn off heater and let cool, Remove blockage, blocked burner flame holes will create soot.

CLEANING AND MAINTENANCE

WARNING: Turn off heater and let cool before cleaning.

CAUTION: You must keep control areas, burner, and circulating air passageways of heater clean. Inspect these areas of heater before each use. Have heater inspected yearly by a qualified service person. Heater may need more frequent cleaning due to excessive lint from carpeting, bedding material, pet hair, etc.

CLEANING BURNER INJECTOR HOLDER AND PILOT AIR INLET HOLE

The primary air inlet holes allow the proper amount of air to mix with the gas. This provides a clean burning flame. Keep these holes clear of dust, dirt, lint, and pet hair. Clean these air inlet holes prior to each heating season. Blocked air holes will create soot. We recommend that you clean the unit every three months during operation and have heater inspected yearly by a qualified service person.

We also recommend that you keep the burner tube and pilot assembly clean and free of dust and dirt. To clean these parts we recommend using compressed air no greater than 30 PSI. Your local computer store, hardware store, or home center may carry compressed air in a can. You can use a vacuum cleaner in the blow position. If using compressed air in a can, please follow the directions on the can. If you don't follow directions on the can, you could damage the pilot assembly.

1. Shut off the unit, including the pilot. Allow the unit to cool for at least thirty minutes.
2. Inspect burner, pilot, and primary air inlet holes on injector holder for dust and dirt (see Figure 44, page 21).
3. Blow air through the ports/slots and holes in the burner.

CLEANING AND MAINTENANCE

Continued

4. Check the injector holder located at the end of the burner tube again. Remove any large particles of dust, dirt, lint, or pet hair with a soft cloth or vacuum cleaner nozzle.
5. Blow air into the primary air holes on the injector holder.
6. In case any large clumps of dust have now been pushed into the burner repeat steps 3 and 4.

Clean the pilot assembly also. A yellow tip on the pilot flame indicates dust and dirt in the pilot assembly. There is a small pilot air inlet hole about two inches from where the pilot flame comes out of the pilot assembly (see Figure 45). With the unit off, lightly blow air through the air inlet hole. You may blow through a drinking straw if compressed air is not available.

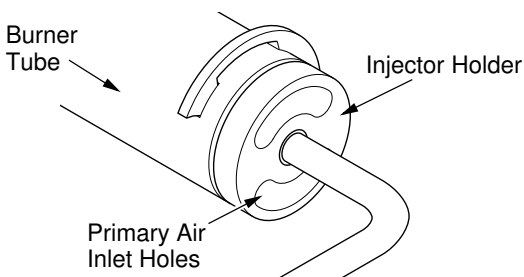

Figure 44 - Injector Holder On Outlet Burner Tube

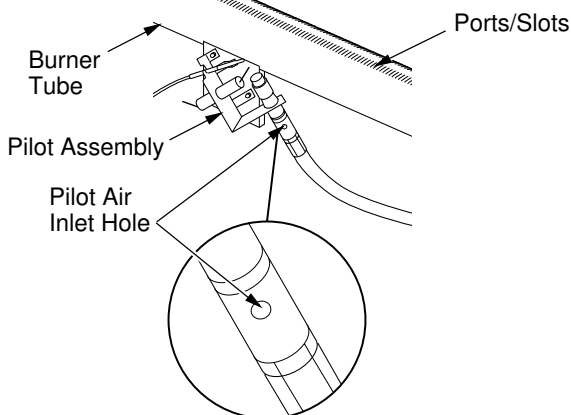

Figure 45 - Pilot Inlet Air Hole

LOGS

- If you remove logs for cleaning, refer to *Installing Logs*, pages 13 through 16, to properly replace logs.
- Replace log(s) if broken or chipped (dime-sized or larger).

MAIN BURNER

Periodically inspect all burner flame holes with the heater running. All slotted burner flame holes should be open with yellow flame present. All round burner flame holes should be open with a small blue flame present. Some burner flame holes may become blocked by debris or rust, with no flame present. If so, turn off heater and let cool, Remove blockage, blocked burner flame holes will create soot.

SPECIFICATIONS

Dual Burner Smoky Mountain Oak and Premium Aged Split Oak Models

	18" Model	24" Models	30" Models
Btu (Variable)	16,000/30,000	20,000/39,000	20,000/39,000
Type Gas	Natural Gas Only		
Ignition Piezo	Piezo	Piezo	
Manifold Pressure	3.5" W.C.	3.5" W.C.	3.5" W.C.
Inlet Gas Pressure (in. of water)			
Maximum	10.5"	10.5"	10.5"
Minimum*	5"	5"	5"
Shipping Weight	36 lbs.	38 lbs.	40 lbs.

* For the purpose of input adjustment

Dual Burner Biltmore Split Oak Models

	18" Model	24" Models	30" Models
Btu (Variable)	16,000/30,000	20,000/39,000	20,000/39,000
Type Gas	Natural Gas Only		
Ignition Piezo	Piezo	Piezo	
Manifold Pressure	3.5" W.C.	3.5" W.C.	3.5" W.C.
Inlet Gas Pressure (in. of water)			
Maximum	10.5"	10.5"	10.5"
Minimum*	5"	5"	5"
Shipping Weight	61 lbs.	66 lbs.	70 lbs.

* For the purpose of input adjustment

Single Burner Seasonal Oak Models

	18" Model	24" Model
Btu (Variable)	16,000/27,000	16,000/31,500
Type Gas	Natural Gas Only	
Ignition Piezo	Piezo	
Manifold Pressure	3.5" W.C.	3.5" W.C.
Inlet Gas Pressure (in. of water)		
Maximum	10.5"	10.5"
Minimum*	5"	5"
Shipping Weight	48 lbs.	52 lbs.

* For the purpose of input adjustment

TROUBLESHOOTING

Note: For additional help, visit DESA International's technical service web site at www.desatech.com.

Note: All troubleshooting items are listed in order of operation.

⚠ WARNING: Turn off and unplug heater and let cool before servicing. Only a qualified service person should service and repair heater.

⚠ CAUTION: Never use a wire, needle, or similar object to clean ODS/pilot. This can damage ODS/pilot unit.

OBSERVED PROBLEM	POSSIBLE CAUSE	REMEDY
When ignitor button is pressed, there is no spark at ODS/pilot	<ol style="list-style-type: none"> 1. Ignitor electrode not connected to ignitor cable 2. Ignitor cable pinched or wet 3. Piezo ignitor nut is loose 4. Broken ignitor cable 5. Bad piezo ignitor 6. Ignitor electrode broken 7. Ignitor electrode positioned wrong 	<ol style="list-style-type: none"> 1. Reconnect ignitor cable 2. Free ignitor cable if pinched by any metal or tubing. Keep ignitor cable dry 3. Tighten nut holding piezo ignitor to base panel of log set. Nut is located behind base panel 4. Replace ignitor cable 5. Replace piezo ignitor 6. Replace pilot assembly 7. Replace pilot assembly
When ignitor button is pressed, there is spark at ODS/pilot but no ignition	<ol style="list-style-type: none"> 1. Gas supply turned off or equipment shutoff valve closed 2. Control knob not in PILOT position 3. Control knob not pressed in while in PILOT position 4. Air in gas lines when installed 5. ODS/pilot is clogged 6. Gas regulator setting is not correct 	<ol style="list-style-type: none"> 1. Turn on gas supply or open equipment shutoff valve 2. Turn control knob to PILOT position 3. Press in control knob while in PILOT position 4. Continue holding down control knob. Repeat igniting operation until air is removed 5. Clean ODS/pilot (see <i>Cleaning and Maintenance</i>, pages 20 & 21) or replace ODS/pilot assembly 6. Replace gas regulator
ODS/pilot lights but flame goes out when control knob is released	<ol style="list-style-type: none"> 1. Control knob not fully pressed in 2. Control knob not pressed in long enough 3. Equipment shutoff valve not fully open 4. Pilot flame not touching thermocouple, which allows thermocouple to cool, causing pilot flame to go out. This problem could be caused by one or both of the following: <ol style="list-style-type: none"> A) Low gas pressure B) Dirty or partially clogged ODS/pilot 5. Thermocouple connection loose at control valve 6. Thermocouple damaged 7. Control valve damaged 	<ol style="list-style-type: none"> 1. Press in control knob fully 2. After ODS/pilot lights, keep control knob pressed in 30 seconds 3. Fully open equipment shutoff valve 4. A) Contact local natural gas company B) Clean ODS/pilot (see <i>Cleaning and Maintenance</i>, pages 20 & 21) or replace ODS/pilot assembly 5. Hand tighten until snug, then tighten 1/4 turn more 6. Replace pilot assembly 7. Replace control valve

TROUBLESHOOTING

Continued

OBSERVED PROBLEM	POSSIBLE CAUSE	REMEDY
Burner does light after ODS/pilot is lit	<ol style="list-style-type: none"> 1. Burner orifice clogged 2. Inlet gas pressure is too low 	<ol style="list-style-type: none"> 1. Clean burner (see <i>Cleaning and Maintenance</i>, page 20) or replace burner orifice 2. Contact local natural gas company
Delayed ignition burner	<ol style="list-style-type: none"> 1. Manifold pressure is too low 2. Burner orifice clogged 	<ol style="list-style-type: none"> 1. Contact local natural gas company 2. Clean burner (see <i>Cleaning and Maintenance</i>, page 20) or replace burner orifice
Burner backfiring during combustion	<ol style="list-style-type: none"> 1. Burner orifice is clogged or damaged 2. Damaged burner 3. Gas regulator defective 	<ol style="list-style-type: none"> 1. Clean burner (see <i>Cleaning and Maintenance</i>, page 20) or replace burner orifice 2. Replace damaged burner 3. Replace gas regulator
Slight smoke or odor during initial operation	<ol style="list-style-type: none"> 1. Not enough air 2. Gas regulator defective 3. Residues from manufacturing processes and logs curing 	<ol style="list-style-type: none"> 1. Check burner for dirt and debris. If found, clean burner (see <i>Cleaning and Maintenance</i>, pages 20 & 21) 2. Replace gas regulator 3. Problem will stop after a few hours of operation
Moisture/condensation noticed on windows	<ol style="list-style-type: none"> 1. Not enough combustion/ventilation air 	<ol style="list-style-type: none"> 1. Refer to <i>Air for Combustion and Ventilation</i> requirements (page 4)
Heater produces a whistling noise when burner is lit	<ol style="list-style-type: none"> 1. Turning control knob to HI position when burner is cold 2. Air in gas line 3. Air passageways on heater blocked 4. Dirty or partially clogged burner orifice 	<ol style="list-style-type: none"> 1. Turn control knob to LO position and let warm up for a minute 2. Operate burner until air is removed from line. Have gas line checked by local natural gas company 3. Observe minimum installation clearances (see pages 7 through 9) 4. Clean burner (see <i>Cleaning and Maintenance</i>, page 20) or replace burner orifice
White powder residue forming within burner box or on adjacent walls or furniture	<ol style="list-style-type: none"> 1. When heated, vapors from furniture polish, wax, carpet cleaners, etc. may turn into white powder residue 	<ol style="list-style-type: none"> 1. Turn heater off when using furniture polish, wax, carpet cleaners, or similar products

TROUBLESHOOTING

Continued

- ⚠ WARNING:** If you smell gas
- Shut off gas supply.
 - Do not try to light any appliance.
 - Do not touch any electrical switch; do not use any phone in your building.
 - Immediately call your gas supplier from a neighbor's phone. Follow the gas supplier's instructions.
 - If you cannot reach your gas supplier, call the fire department.

IMPORTANT: Operating heater where impurities in air exist may create odors. Cleaning supplies, paint, paint remover, cigarette smoke, cements and glues, new carpet or textiles, etc., create fumes. These fumes may mix with combustion air and create odors. These odors will disappear over time.

OBSERVED PROBLEM	POSSIBLE CAUSE	REMEDY
Heater produces a clicking/ticking noise just after burner is lit or shut off	1. Metal expanding while heating or contracting while cooling	1. This is common with most heaters. If noise is excessive, contact qualified service person
Heater produces unwanted odors	1. Heater burning vapors from paint, hair spray, glues, cleaners, chemicals, new carpet, etc. (See <i>IMPORTANT</i> statement above) 2. Gas leak. See Warning statement at top of page	1. Open window and ventilate room. Stop using odor causing products while heater is running 2. Locate and correct all leaks (see <i>Checking Gas Connections</i> , pages 12 and 13)
Heater shuts off in use (ODS operates)	1. Not enough fresh air is available 2. Low line pressure 3. ODS/pilot is partially clogged	1. Open window and/or door for ventilation 2. Contact local natural gas company 3. Clean ODS/pilot (see <i>Cleaning and Maintenance</i> , pages 20 & 21)
Gas odor even when control knob is in OFF position	1. Gas leak. See Warning statement at top of page 2. Control valve defective	1. Locate and correct all leaks (see <i>Checking Gas Connections</i> , pages 12 and 13) 2. Replace control valve
Gas odor during combustion	1. Foreign matter between control valve and burner 2. Gas leak. See Warning statement at top of page	1. Take apart gas tubing and remove foreign matter 2. Locate and correct all leaks (see <i>Checking Gas Connections</i> , pages 12 and 13)
Logs set cycles to pilot, but room temperature drops to a lower than ideal level before log set comes back on	1. Thermostat sensing bulb needs to be repositioned	1. Reposition thermostat sensing bulb (see <i>instructions for Optional Positioning of Thermostat Sensing Bulb</i> , page 25)

OPTIONAL POSITIONING OF THERMOSTAT SENSING BULB For Masonry and Factory-built Metal Fireplace

If your log set cycles to pilot, but the room temperature drops to a lower than ideal comfort level before the log set comes back on, you may want to reposition the thermostat sensing bulb.

The thermostat sensing bulb is located near the gas valve assembly on the mounting bracket. This location allows the thermostat to keep the room temperature at an ideal comfort level for most fireplace applications. For positioning the thermostat sensing bulb elsewhere, an adhesive-backed mounting clip is available.

Tools needed: 1/4" hex driver or socket

1. Remove logs. Locate the gas valve assembly and thermostat sensing bulb (see Figure 46).
2. With 1/4" hex driver or socket, loosen the thermostat screw. Carefully slide the thermostat sensing bulb out of the retaining clamp (see Figure 48).

Note: Do not remove the screw. Make sure you tighten the screw after removing the thermostat sensing bulb.

IMPORTANT: Do not force or bend the thermostat sensing bulb or capillary.

3. The thermostat sensing bulb may be located to the lower right front side of fireplace. Determine location of sensing bulb, but do not mount sensing bulb until step 5. If you have a masonry fireplace, see Figure 49 for location. If you have a factory-built metal fireplace, see Figure 50 for location. If your fireplace has glass doors, position sensing bulb directly behind door gap on right bottom side (see Figure 51).

4. The mounting clip must be a minimum of 3" from bottom of fireplace to prevent crimping of capillary. Once you have decided on a location, clean the area thoroughly. Remove the paper backing from the adhesive on back of mounting clip. Press the clip into the new location so that the thermostat sensing bulb will be positioned vertically with the capillary at the bottom (see Figure 52). Slide the thermostat sensing bulb into the clip.

IMPORTANT: Do not crimp capillary.

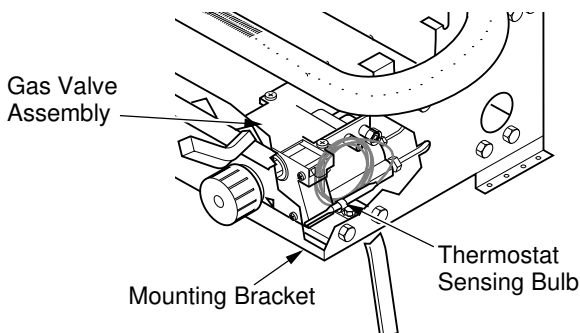

Figure 46 - Location of Gas Valve Assembly and Thermostat Sensing Bulb

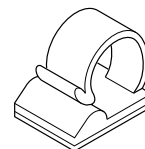

Figure 47 - Adhesive-backed Mounting Clip

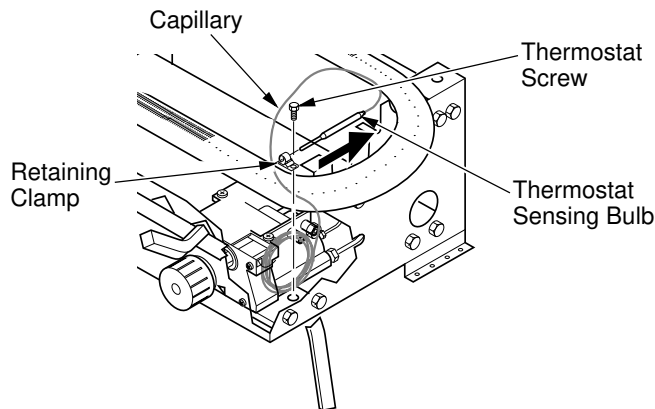

Figure 48 - Removing Thermostat Sensing Bulb

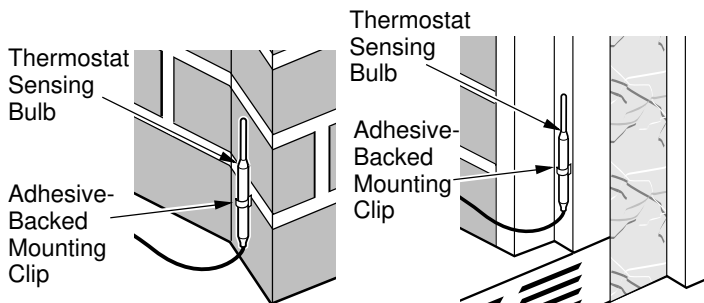

Figure 49 - Locating Thermostat Sensing Bulb on Masonry Fireplace

Figure 50 - Locating Thermostat Sensing Bulb on Factory-built Metal Fireplace

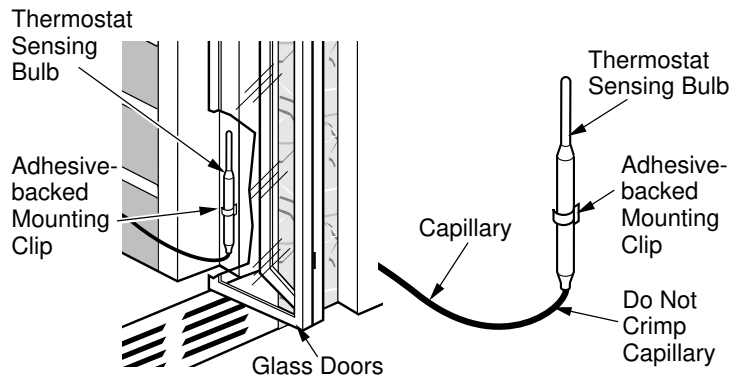

Figure 51 - Installing Thermostat Sensing Bulb behind Glass Doors

Figure 52 - Positioning the Thermostat Sensing Bulb in the Vertical Position with the Capillary at the Bottom

ILLUSTRATED PARTS BREAKDOWN

Variable Manually-Controlled

CGD3018N, CGD3924N
 CGD3930N, CCL3018N
 CCL3924N

Smoky Mountain Oak Logs

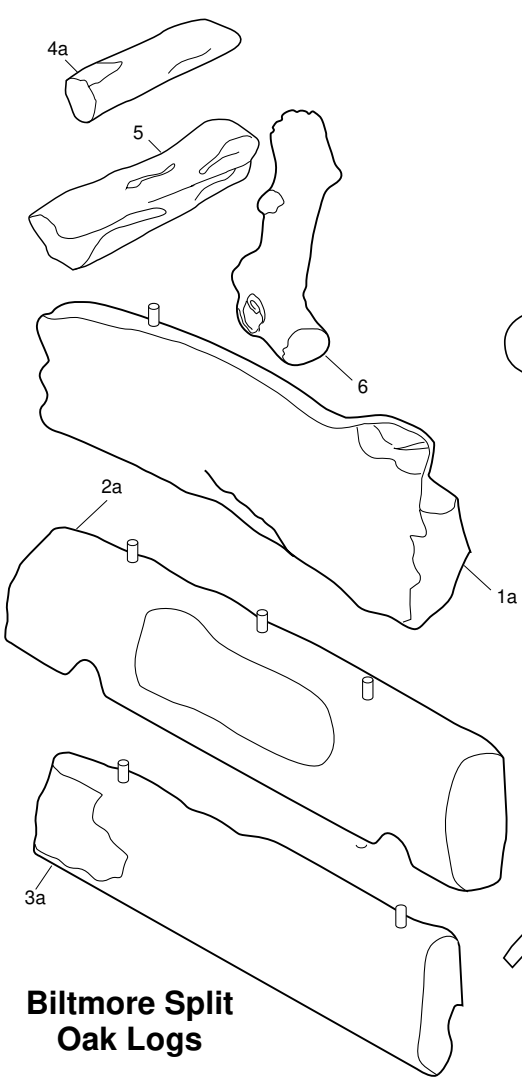
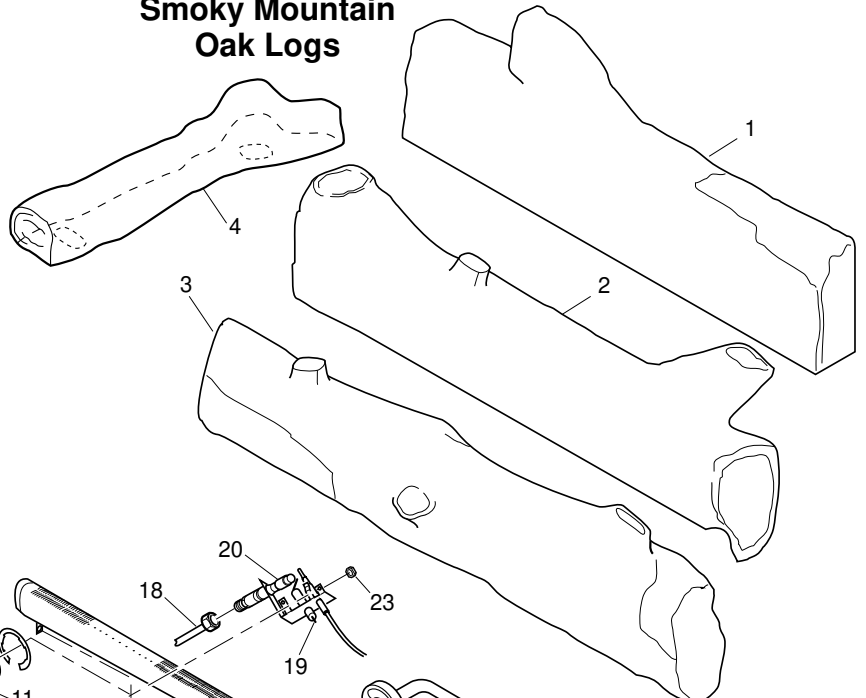

Biltmore Split Oak Logs

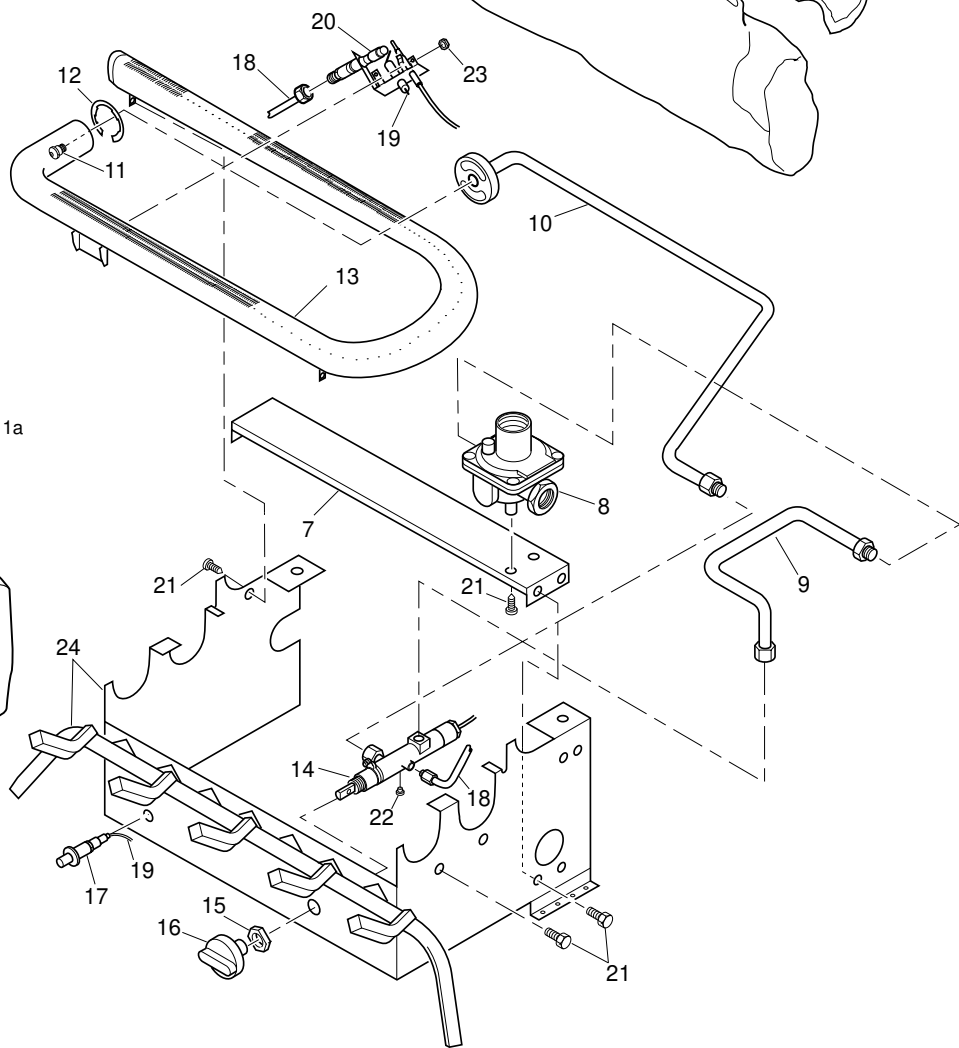

PARTS LIST

This list contains replaceable parts used in your heater. When ordering parts, follow the instructions listed under *Replacement Parts* on page 36 of this manual.

Variable Manually-Controlled

KEY NO.	PART NUMBER			DESCRIPTION	QTY.
	CCL3018N CGD3018N	CCL3924N CGD3924N	CGD3930N		
1	103008-02	103008-01	103008-03	Back Log (#1)	1
1a	105925-04	105925-03	—	Back Log (#1)	1
2	103009-02	103009-01	103009-03	Middle Log (#2)	1
2a	105924-04	105924-03	—	Middle Log (#2)	1
3	103010-02	103010-01	103010-03	Front Log (#3)	1
3a	105923-04	105923-03	—	Front Log (#3)	1
4	103011-02	103011-01	103011-01	Crossover Log (#4)	1
4a	105926-04	105926-03	—	Left Back Crossover Log (#4)	1
5	105927-04	105927-03	—	Left Top Crossover Log (#5)	1
6	105928-04	105928-04	—	Right Bottom Crossover Log (#6)	1
7	102844-02	102844-01	102844-01	Lower Bracket	1
8	098867-14	098867-14	098867-14	Gas Regulator	1
9	102798-01	102798-01	102798-01	Inlet Tube	1
10	102779-03	102779-01	102779-01	Outlet Burner Tube	1
11	099056-26	099056-16	099056-16	Burner Orifice Injector	1
12	102843-01	102843-01	102843-01	Burner Clip	1
13	102980-01	102772-01	102772-01	Burner	1
14	102568-07	102568-05	102568-05	Control Valve	1
15	098508-01	098508-01	098508-01	Valve Retainer Nut	1
16	098354-01	098354-01	098354-01	Control Knob	1
17	102445-01	102445-01	102445-01	Piezo Ignitor	1
18	099387-08	099387-08	099387-08	Pilot Tube	1
19	098271-10	098271-10	098271-10	Ignitor Cable	1
20	104285-01	104285-01	104285-01	ODS Pilot	1
21	M11084-38	M11084-38	M11084-38	Hex Screw, #8-18 x .38	8
22	098276-01	098276-01	098276-01	Hex Head Plug, 1/8 NPT	1
23	098249-01	098249-01	098249-01	Nut, M5	2
24	102775-04CK	102775-01CK	102775-03CK	Painted Base Assembly	1
PARTS AVAILABLE — NOT SHOWN					
	100563-01	100563-01	100563-01	Warning Plate	1
	101055-02	101055-02	101055-02	Lighting Instructions Plate	1
	100565-01	100565-01	100565-01	Warning Plate Fastener	1
	100639-01	100639-01	100639-01	Caution Decal	1
	101449-04	101449-04	101449-04	Control Position Decal	1
	101137-02	101137-02	101137-02	Hardware Kit	1
	GA6060	GA6060	GA6060	Lava Rock	1

ILLUSTRATED PARTS BREAKDOWN

Thermostatically-Controlled
Smoky Mountain Oak Models

CGD3018NT
CGD3924NT
CGD3930NT

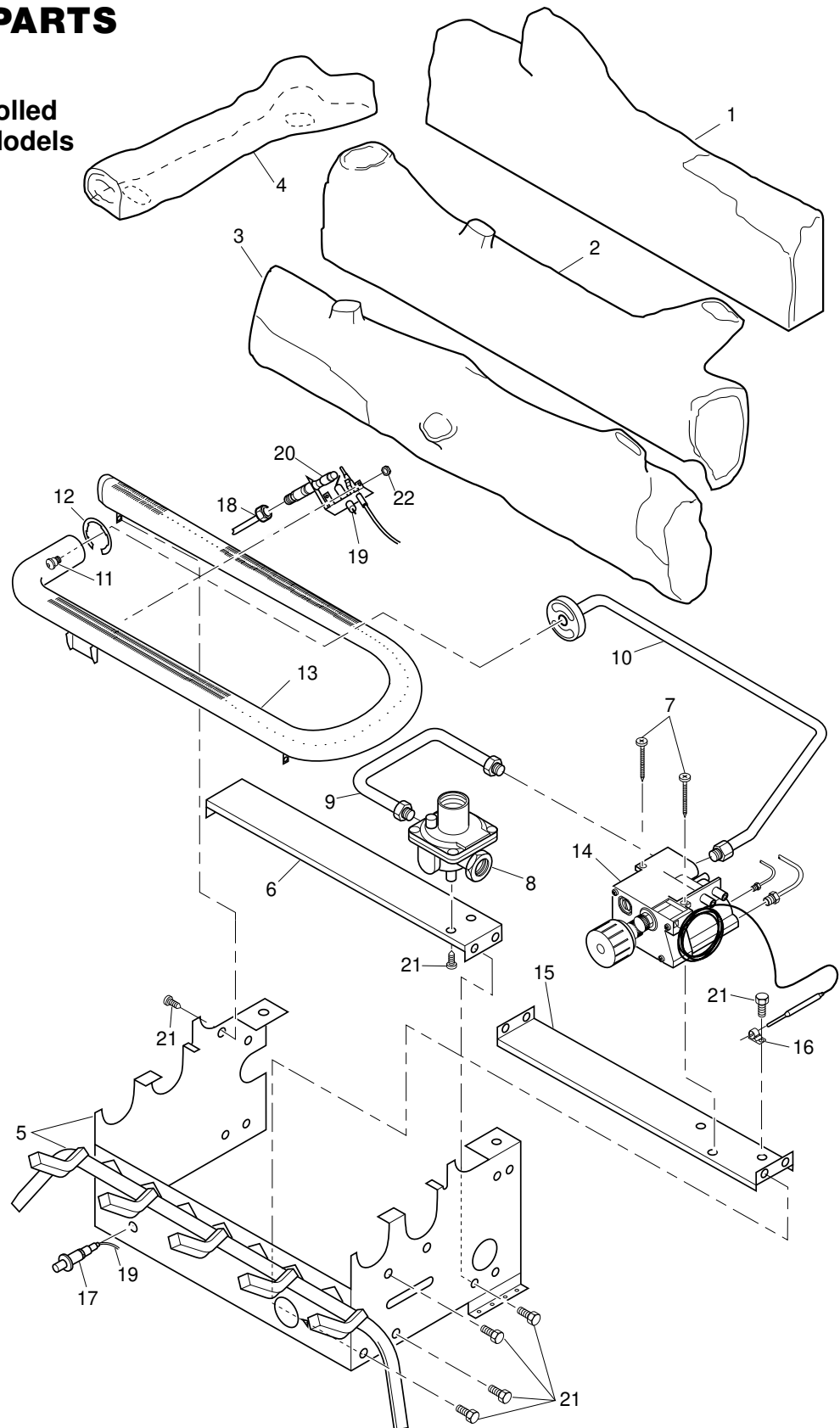

For more information, visit www.desatech.com

PARTS LIST

This list contains replaceable parts used in your heater. When ordering parts, follow the instructions listed under *Replacement Parts* on page 36 of this manual.

Thermostatically-Controlled Smoky Mountain Oak Models

KEY NO.	CGD3018NT PART NUMBER	CGD3924NT PART NUMBER	CGD3930NT PART NUMBER	DESCRIPTION	QTY.
1	103008-02	110090-03	103008-03	Back Log (#1)	1
2	103009-02	110090-02	103009-03	Middle Log (#2)	1
3	103010-02	110090-01	103010-03	Front Log (#3)	1
4	103011-02	110090-04	103011-01	Crossover Log (#4)	1
5	102775-09CK	102775-05CK	102775-07CK	Painted Base Assembly	1
6	102844-02	102844-01	102844-01	Lower Bracket	1
7	099211-01	099211-01	099211-01	Hex Screw, 10-16 x 2.50	2
8	098867-14	098867-14	098867-14	Gas Regulator	1
9	102810-03	102810-03	102810-03	Inlet Tube	1
10	102983-03	102983-01	102983-01	Outlet Burner Tube	1
11	099056-26	099056-16	099056-16	Burner Orifice Injector	1
12	102843-01	102843-01	102843-01	Burner Clip	1
13	102980-01	102772-01	102772-01	Burner	1
14	101329-21	101329-20	101329-20	Thermostat Gas Valve Assembly	1
15	102979-02	102979-01	102979-01	Thermostat Bracket	1
16	098544-01	098544-01	098544-01	Thermobulb Clip	1
17	102445-01	102445-01	102445-01	Piezo Ignitor	1
18	099387-09	099387-09	099387-09	Pilot Tube	1
19	098271-10	098271-10	098271-10	Ignitor Cable	1
20	104285-01	104285-01	104285-01	ODS Pilot	1
21	M11084-38	M11084-38	M11084-38	Hex Screw, #8-18 x .38	12
22	098249-01	098249-01	098249-01	Nut, M5	2
PARTS AVAILABLE — NOT SHOWN					
	100563-01	100563-01	100563-01	Warning Plate	1
	101054-01	101054-01	101054-01	Lighting Instructions Plate	1
	100565-01	100565-01	100565-01	Warning Plate Fastener	1
	100639-01	100639-01	100639-01	Caution Decal	1
	101137-02	101137-02	101137-02	Hardware Kit	1
	GA6060	GA6060	GA6060	Lava Rock	1

ILLUSTRATED PARTS BREAKDOWN

Thermostatically-Controlled Biltmore Split Oak
Model

CCL3018NT

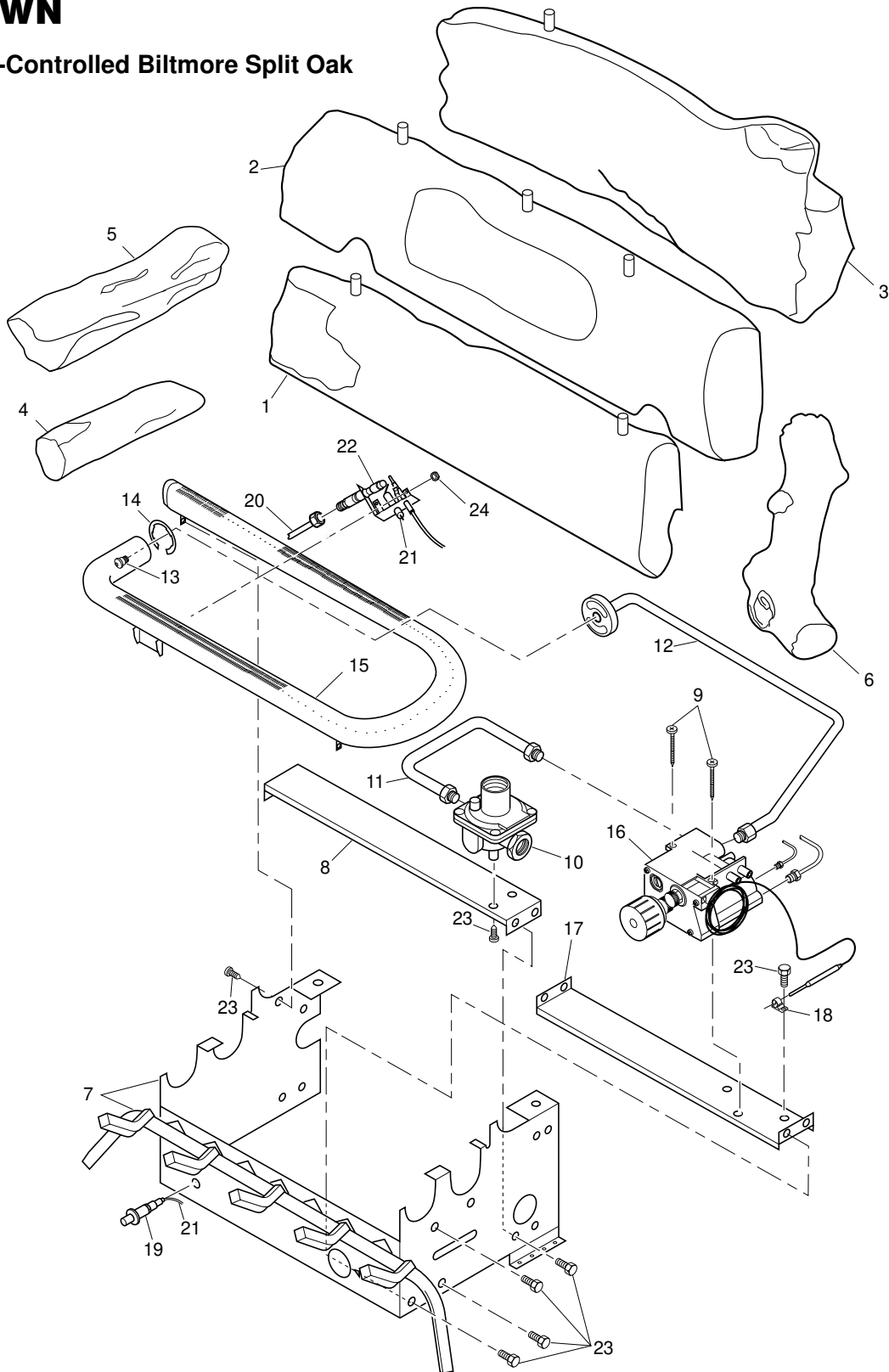

For more information, visit www.desatech.com

PARTS LIST

This list contains replaceable parts used in your heater. When ordering parts, follow the instructions listed under *Replacement Parts* on page 36 of this manual.

Thermostatically-Controlled Biltmore Split Oak Model

KEY NO.	CCL3018NT PART NUMBER	DESCRIPTION	QTY.
1	105923-04	Front Log (#1)	1
2	105924-04	Middle Log (#2)	1
3	105925-04	Back Log (#3)	1
4	105926-04	Left Back Crossover Log (#4)	1
5	105927-04	Left Top Crossover Log (#5)	1
6	105928-04	Right Bottom Crossover Log (#6)	1
7	102775-09CK	Painted Base Assembly	1
8	102844-02	Lower Bracket	1
9	099211-01	Hex Screw, 10-16 x 2.50	2
10	098867-14	Gas Regulator	1
11	102810-03	Inlet Tube	1
12	102983-03	Outlet Burner Tube	1
13	099056-26	Burner Orifice Injector	1
14	102843-01	Burner Clip	1
15	102980-01	Burner	1
16	101329-21	Thermostat Gas Valve Assembly	1
17	102979-02	Thermostat Bracket	1
18	098544-01	Thermostat Clip	1
19	102445-01	Piezo Ignitor	1
20	099387-09	Pilot Tube	1
21	098271-10	Ignitor Cable	1
22	104285-01	ODS Pilot	1
23	M11084-38	Hex Screw, #8-18 x .38	12
24	098249-01	Nut, M5	2
PARTS AVAILABLE — NOT SHOWN			
	100563-01	Warning Plate	1
	101054-01	Lighting Instructions Plate	1
	100565-01	Warning Plate Fastener	1
	100639-01	Caution Decal	1
	101137-02	Hardware Kit	1
	GA6060	Lava Rock	1

ILLUSTRATED PARTS BREAKDOWN

Thermostatically-Controlled
Biltmore Split Oak Model

CCL3924NT, CCL3930NTA

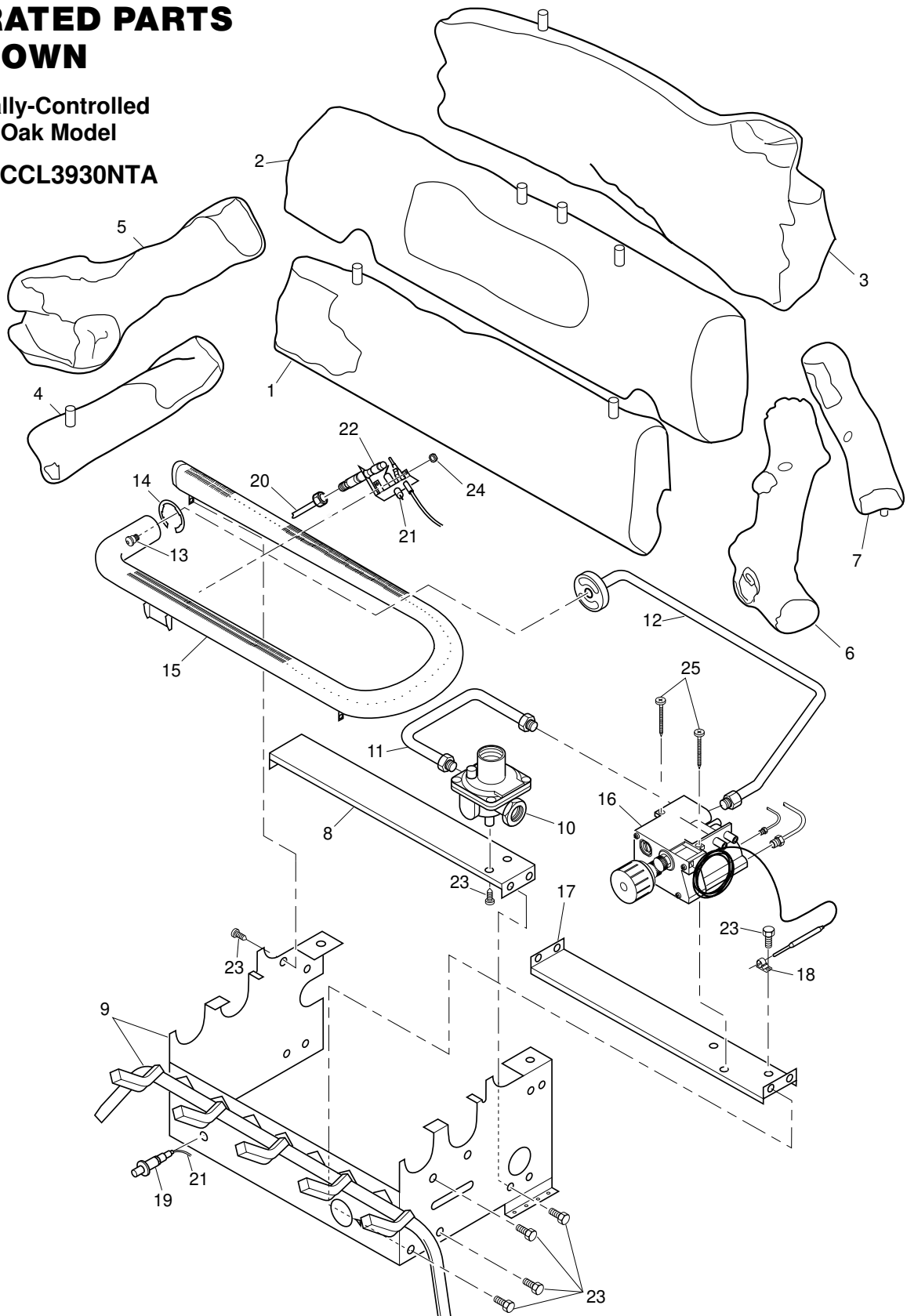

For more information, visit www.desatech.com

PARTS LIST

This list contains replaceable parts used in your heater. When ordering parts, follow the instructions listed under *Replacement Parts* on page 36 of this manual.

Thermostatically-Controlled Biltmore Split Oak Model

KEY NO.	PART NUMBER		DESCRIPTION	QTY.
	CCL3924NT	CCL3930NTA		
1	105923-03	105923-02	Front Log (#1)	1
2	105924-03	105924-02	Middle Log (#2)	1
3	105925-03	105925-02	Back Log (#3)	1
4	105926-03	105926-02	Left Back Crossover Log (#4)	1
5	105927-03	105927-03	Left Top Crossover Log (#5)	1
6	105928-04	105928-02	Right Bottom Crossover Log (#6)	1
7	—	105929-02	Right Top Crossover Log (#7)	1
8	102844-01	102844-01	Lower Bracket	1
9	102775-05CK	102775-07CK	Painted Base Assembly	1
10	098867-14	098867-14	Gas Regulator	1
11	102810-03	102981-01	Inlet Tube	1
12	102983-01	102983-01	Outlet Burner Tube	1
13	099056-16	099056-16	Burner Orifice Injector	1
14	102843-01	102843-01	Burner Clip	1
15	102772-01	102772-01	Burner	1
16	101329-20	101329-20	Thermostat Gas Valve Assembly	1
17	102979-01	102979-01	Thermostat Bracket	1
18	098544-01	098544-01	Thermostat Clip	1
19	102445-01	102445-01	Piezo Ignitor	1
20	099387-09	099387-09	Pilot Tube	1
21	098271-10	098271-10	Ignitor Cable	1
22	104285-01	104285-01	ODS Pilot	1
23	M11084-38	M11084-38	Hex Screw, #8-18 x .38	12
24	098249-01	098249-01	Nut, M5	2
25	099211-01	099211-01	Hex Screw, 10-16 x 2.50	2
PARTS AVAILABLE — NOT SHOWN				
	100563-01	100563-01	Warning Plate	1
	101054-01	101054-01	Lighting Instructions Plate	1
	100565-01	100565-01	Warning Plate Fastener	1
	100639-01	100639-01	Caution Decal	1
	101137-02	101137-02	Hardware Kit	1
	GA6060	GA6060	Lava Rock	1
	—	102030-01	Auxiliary Thermostat Mounting Clip	1

ILLUSTRATED PARTS BREAKDOWN

Variable Manually-Controlled
Seasonal Oak Models
CRL2718N, CRL3124N

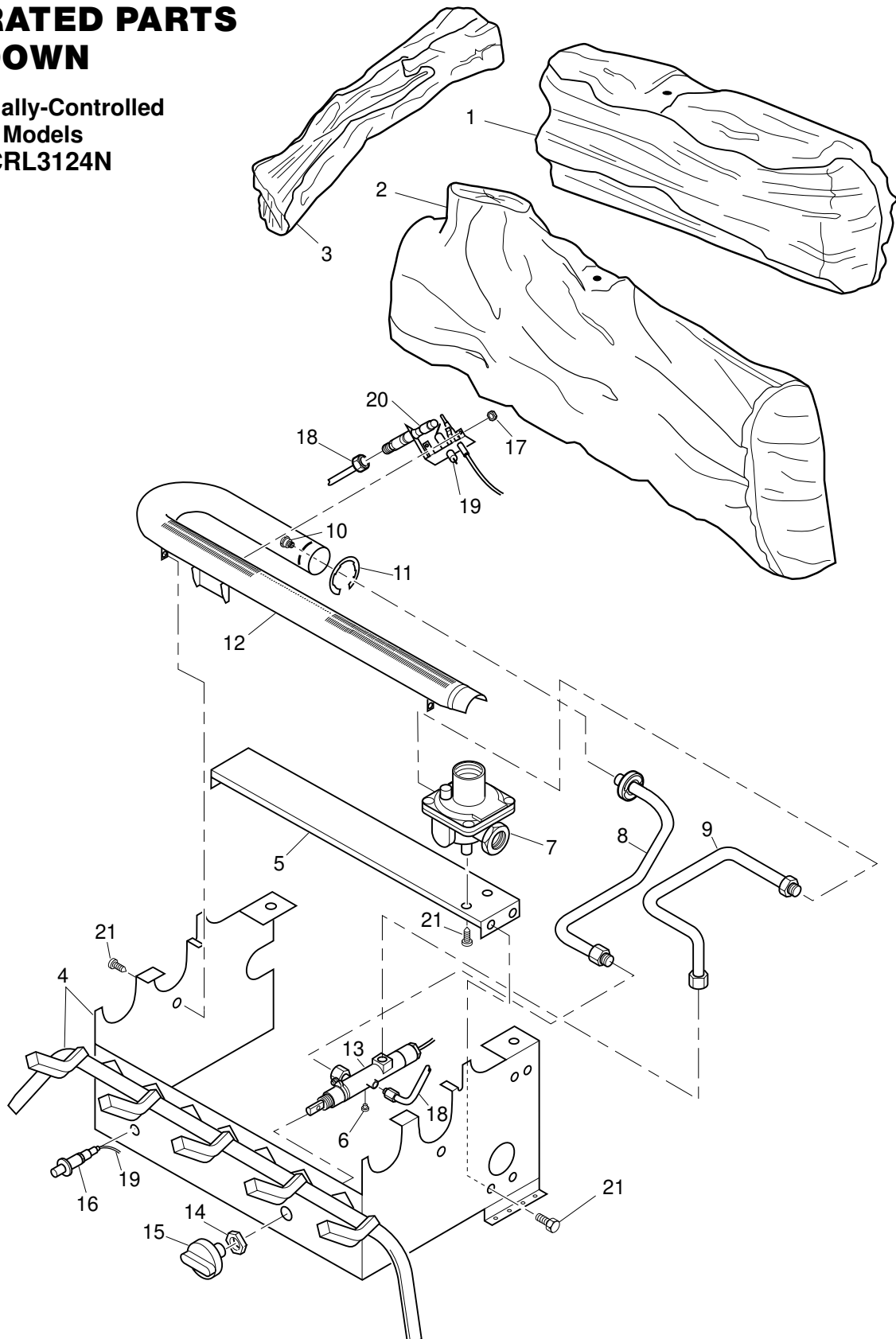

For more information, visit www.desatech.com

PARTS LIST

This list contains replaceable parts used in your heater. When ordering parts, follow the instructions listed under *Replacement Parts* on page 36 of this manual.

Variable Manually-Controlled Mountain Oak Models

KEY NO.	PART NUMBER		DESCRIPTION	QTY.
	CRL2718N	CRL3124N		
1	110243-01	110242-01	Back Log (#1)	1
2	110243-02	110242-02	Front Log (#2)	1
3	110242-03	110242-03	Crossover Log (#3)	1
4	102775-02CK	102775-01CK	Painted Base Assembly	1
5	102844-01	102844-01	Lower Bracket	1
6	098279-01	098279-01	Hex Head Plug, 1/8" NPT	1
7	098867-14	098867-14	Gas Regulator	1
8	102780-01	102780-01	Outlet Burner Tube	1
9	102798-01	102798-01	Inlet Tube	1
10	099056-20	099056-18	Burner Orifice Injector	1
11	102843-01	102843-01	Burner Clip	1
12	102963-01	102773-01	Burner	1
13	102568-07	102568-07	Control Valve	1
14	098508-01	098508-01	Valve Retainer Nut	1
15	098354-01	098354-01	Control Knob	1
16	102445-01	102445-01	Piezo Ignitor	1
17	098249-01	098249-01	Nut, M5	2
18	099387-08	099387-08	Pilot Tube	1
19	098271-10	098271-10	Ignitor Cable	1
20	104285-01	104285-01	ODS Pilot	1
21	M11084-38	M11084-38	Screw, Hex Head (#8-18 x .38)	8
PARTS AVAILABLE — NOT SHOWN				
	100563-01	100563-01	Warning Plate	1
	101055-02	101055-02	Lighting Instructions Plate	1
	100565-01	100565-01	Warning Plate Fastener	1
	100639-01	100639-01	Caution Decal	1
	101449-04	101449-04	Control Position Decal	1
	101137-02	101137-02	Hardware Kit	1
	GA6060	GA6060	Lava Rock	1

REPLACEMENT PARTS

Note: Use only original replacement parts. This will protect your warranty coverage for parts replaced under warranty.

PARTS UNDER WARRANTY

Contact authorized dealers of this product. If they can't supply original replacement part(s), contact your nearest Parts Central (see page 39) or call DESA International's Technical Service Department at 1-866-672-6040 for referral information.

When calling DESA International, have ready

- your name
- your address
- model and serial numbers of your heater
- how heater was malfunctioning
- type of gas used (propane/LP or natural gas)
- purchase date

Usually, we will ask you to return the part to the factory.

PARTS NOT UNDER WARRANTY

Contact authorized dealers of this product. If they can't supply original replacement part(s), contact your nearest Parts Central (see page 39) or call DESA International at 1-866-672-6040 for referral information.

When calling DESA International, have ready

- model number of your heater
- the replacement part number

SERVICE HINTS

When Gas Pressure Is Too Low

- pilot will not stay lit
- burners will have delayed ignition
- heater will not produce specified heat

You may feel your gas pressure is too low. If so, contact your local natural gas supplier.

TECHNICAL SERVICE

You may have further questions about installation, operation, or troubleshooting. If so, contact DESA International's Technical Service Department at 1-866-672-6040. When calling please have your model and serial numbers of your heater ready.

You can also visit DESA International's Technical Service web site at www.desatech.com.

ACCESSORIES

Purchase these fireplace accessories from your local dealer. If they can not supply these accessories, call DESA International's Sales Department at 1-866-672-6040 for referral information. You can also write to the address listed on the back page of this manual.

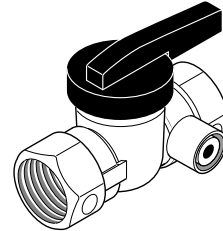

EQUIPMENT SHUTOFF VALVE - GA5010

For all models. Equipment shutoff valve with 1/8" NPT tap. Fits 1/2" NPT pipe.

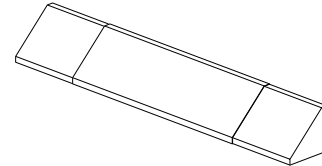

FIREPLACE HOOD

Black - GA6050

Brass - GA6052

Antique Brass - GA6053

For all models. Helps deflect heat away from mantel or wall above fireplace.

INFORMATION VIDEO - 108917-01

For all models. A care and maintenance video is available by calling 1-866-672-6040.

DAMPER CLAMP - GA6080 (Not Shown)

Permanently opens chimney flue damper for vented operation. For use only with non-thermostat accessories.

LAVA ROCK - GA6060 (Not Shown)

For all models. Order when additional rock is desired. (2 lb. bag)

OWNER'S REGISTRATION FORM

In order to provide better customer service for this and future purchases, we recommend that you register your product with us. You can register online at www.desatech.com. If access to our website is not available to you, please complete this Owner's Registration Form and mail to the address on the back of this owner's manual. Please provide the following product information:

Brand: _____ (Comfort Glow, Vanguard, etc.)
 Model: _____ (EFP33PR, VTGH33NR, etc.)
 Date Purchased: _____ *Note: Keep receipt for warranty verification.*
 Serial Number: _____ 7 or 9 digit number located on product or identification tag.
 First Name: _____ Last Name: _____
 Address: _____
 City: _____ State: _____ Zip: _____ Country: _____
 Home Phone: (____) _____ - _____
 E-Mail: _____

Please answer the following questions to register your product with DESA International:

1. Where will the product be used?
 Living/Family Room Office/Warehouse Utility Shed/Outbuilding Garage Bedroom Bathroom Other
2. If you bought this product yourself, did you plan to purchase this type of product before going into the store? Yes No
3. Who selected the product? Male Female Both
4. What is the population of your area? Under 10,000 10,000 to 25,000 25,000 to 50,000 50,000 to 100,000
 100,000 to 250,000 Over 250,000
5. What is your primary source of heat? Propane (LP Gas) Fuel Oil Wood Natural Gas Electric Other
6. How was the product installed? Professional Installer Self Other
7. Cost of product excluding sales tax? \$ _____
8. Cost to install product? \$ _____
9. Type of store where product was purchased? Hardware Propane Dealer Natural Gas/Utility Co. Home Center/Builder's Supply
 Fireplace or Hearth Shop Farm Store Other
10. What motivated you to buy this product? Sudden Cold Weather Replace Older Model D.I.Y. Home Project
 Emergency Back-Up Heat Heater was on Sale Energy Savings/High Efficiency Construction Project Other
11. How did you learn about this product brand? Advertising Relative or Friend Store Display Other _____
12. Level of Education of Purchaser: Some High School Completed High School Completed College Completed Graduate School
13. Age of Purchaser: Under 20 20 - 29 30 - 39 40 - 49 50 - 59 60 or Over
14. Buyer's total annual household income: Under \$15,000 \$15,000 to \$19,999 \$20,000 to \$34,999 \$35,000 to \$49,999
 \$50,000 to \$74,999 \$75,000 to \$99,999 \$100,000 and Over
15. Store where product was purchased:
 Name: _____
 City: _____ State: _____

16. In choosing this product, how important were the following:

	Not Important	Somewhat Important	Very Important
Availability	<input type="radio"/>	<input type="radio"/>	<input type="radio"/>
Price	<input type="radio"/>	<input type="radio"/>	<input type="radio"/>
Brand Name	<input type="radio"/>	<input type="radio"/>	<input type="radio"/>
Overall Quality	<input type="radio"/>	<input type="radio"/>	<input type="radio"/>
Heat Output	<input type="radio"/>	<input type="radio"/>	<input type="radio"/>
Made in USA	<input type="radio"/>	<input type="radio"/>	<input type="radio"/>
Warranty	<input type="radio"/>	<input type="radio"/>	<input type="radio"/>
Local Service	<input type="radio"/>	<input type="radio"/>	<input type="radio"/>
Value for Price	<input type="radio"/>	<input type="radio"/>	<input type="radio"/>
Prior Brand Experience	<input type="radio"/>	<input type="radio"/>	<input type="radio"/>
Controls Location	<input type="radio"/>	<input type="radio"/>	<input type="radio"/>
Thermostat, Remote, or Manual Operation	<input type="radio"/>	<input type="radio"/>	<input type="radio"/>
Ease of Operation	<input type="radio"/>	<input type="radio"/>	<input type="radio"/>
Special Features	<input type="radio"/>	<input type="radio"/>	<input type="radio"/>
Salesperson's Recommendation	<input type="radio"/>	<input type="radio"/>	<input type="radio"/>
Friend/Relative's Recommendation	<input type="radio"/>	<input type="radio"/>	<input type="radio"/>
Portability	<input type="radio"/>	<input type="radio"/>	<input type="radio"/>
Quiet Operation	<input type="radio"/>	<input type="radio"/>	<input type="radio"/>

TAPE

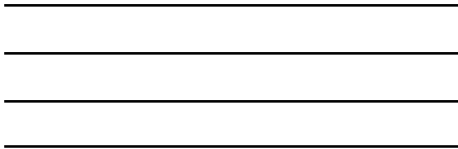

Postage
Required

DESATM
INTERNATIONAL
2701 Industrial Drive
P.O. Box 90004
Bowling Green, KY 42102-9004

TAPE

PARTS CENTRAL

These Parts Centrals are privately owned businesses. They have agreed to support our customer's needs by providing original replacement parts and accessories.

Baltimore Electric

1348 Dixwell Avenue
Hamden, CT 06514-0322
1-800-397-7553
203-248-7553
Parts Department

Portable Heater Parts

342 N. County Rd. 400 East
Valparaiso, IN 46383-9704
All States
219-462-7441
1-888-619-7060
sales@portableheaterparts.com
techservice@portableheaterparts.com

FBD

1349 Adams Street
Bowling Green, KY 42103-3414
270-846-1199
1-800-654-8534
Fax: 1-800-846-0090
franktalk@aol.com

Master Parts Dist.

1251 Mound Ave NW
Grand Rapids, MI 49504-2672
616-791-0505
1-800-446-1446
Fax: 616-791-8270
www.nbmc.com

Washer Equipment Co.

1715 Main Street
Kansas City, MO 64108-2195
KS, MO, AR
816-842-3911
www.washerparts.com

East Coast Energy Products

707 Broadway
W. Long Branch, NJ
07764-1542
732-870-8809
1-800-755-8809
www.njplaza.com/ecep

Halco Enterprises

208 Carter Drive, Unit 21
West Chester, PA 19382-4500
610-430-7717
1-800-368-0803
www.halcoenterprises.com

Laportes Parts & Service

2444 N. 5th Street
Hartsville, SC 29550-7704
843-332-0191
Parts Department

Cans Unlimited, Inc.

P.O. Box 645
Taylor, SC 29687-0013
All States
803-879-3009
1-800-845-5301
cuissales@aol.com

WARRANTY INFORMATION

KEEP THIS WARRANTY

Model _____
Serial No. _____
Date Purchased _____

Always specify model and serial numbers when communicating with the factory.

We reserve the right to amend these specifications at any time without notice. The only warranty applicable is our standard written warranty. We make no other warranty, expressed or implied.

LIMITED WARRANTY COMFORT GLOW VENT-FREE NATURAL GAS LOG HEATERS

DESA International warrants this product to be free from defects in materials and components for two (2) years from the date of first purchase, provided that the product has been properly installed, operated and maintained in accordance with all applicable instructions. To make a claim under this warranty the Bill of Sale or cancelled check must be presented.

This warranty is extended only to the original retail purchaser. This warranty covers the cost of part(s) required to restore this heater to proper operating condition and an allowance for labor when provided by a DESA Authorized Service Center. Warranty part(s) MUST be obtained through authorized dealers of this product and/or DESA International who will provide original factory replacement parts. Failure to use original factory replacement parts voids this warranty. The heater MUST be installed by a qualified installer in accordance with all local codes and instructions furnished with the unit.

This warranty does not apply to parts that are not in original condition because of normal wear and tear, or parts that fail or become damaged as a result of misuse, accidents, lack of proper maintenance or defects caused by improper installation. Travel, diagnostic cost, labor, transportation and any and all such other costs related to repairing a defective heater will be the responsibility of the owner.

TO THE FULL EXTENT ALLOWED BY THE LAW OF THE JURISDICTION THAT GOVERNS THE SALE OF THE PRODUCT; THIS EXPRESS WARRANTY EXCLUDES ANY AND ALL OTHER EXPRESSED WARRANTIES AND LIMITS THE DURATION OF ANY AND ALL IMPLIED WARRANTIES, INCLUDING WARRANTIES OF MERCHANTABILITY AND FITNESS FOR A PARTICULAR PURPOSE TO TWO (2) YEARS ON ALL COMPONENTS FROM THE DATE OF FIRST PURCHASE; AND DESA INTERNATIONAL'S LIABILITY IS HEREBY LIMITED TO THE PURCHASE PRICE OF THE PRODUCT AND DESA INTERNATIONAL SHALL NOT BE LIABLE FOR ANY OTHER DAMAGES WHATSOEVER INCLUDING INDIRECT, INCIDENTAL OR CONSEQUENTIAL DAMAGES.

Some states do not allow a limitation on how long an implied warranty lasts or an exclusion or limitation of incidental or consequential damages, so the above limitation on implied warranties, or exclusion or limitation on damages may not apply to you.

This warranty gives you specific legal rights, and you may also have other rights that vary from state to state.

For information about this warranty write:

DESATM
INTERNATIONAL
2701 Industrial Drive
P.O. Box 90004
Bowling Green, KY 42102-9004
www.desatech.com



107123 01

NOT A UPC

107123-01
Rev. F
10/02

For more information, visit www.desatech.com