

# 5 Series OptiHeat

VAPOR INJECTION TECHNOLOGY

504W11 Geothermal Hydronic Heat Pump  
3 to 5 Tons NEW Series

Installation Information

Water Piping Connections

Electrical Data

Startup Procedures

Preventive Maintenance





## Table of Contents

---

Model Nomenclature .....	4
General Installation Information .....	5
Field Connected Water Piping .....	6-7
Hydronic Section .....	8-9
Accessories and Options .....	10-11
Electrical Data .....	12-13
Wiring Schematics .....	14-15
Unit Startup .....	16
Aurora Base Control .....	17-22
Reference Calculations .....	23
Legend and Notes .....	23
Water Pressure Drop .....	23
Pressure Drop .....	24
Operating Limits .....	25
Physical Data .....	25
Flow Rates .....	25
Thermistor and Compressor Resistance .....	26
Operating Parameters .....	26-27
Antifreeze Correction .....	28
Troubleshooting Guideline for Refrigerant Circuit .....	28
Heating and Cooling Cycle Analysis .....	29
Troubleshooting Form .....	30
Troubleshooting .....	31
Preventive Maintenance .....	32
Service Parts .....	33
Revision Guide .....	35

# Model Nomenclature

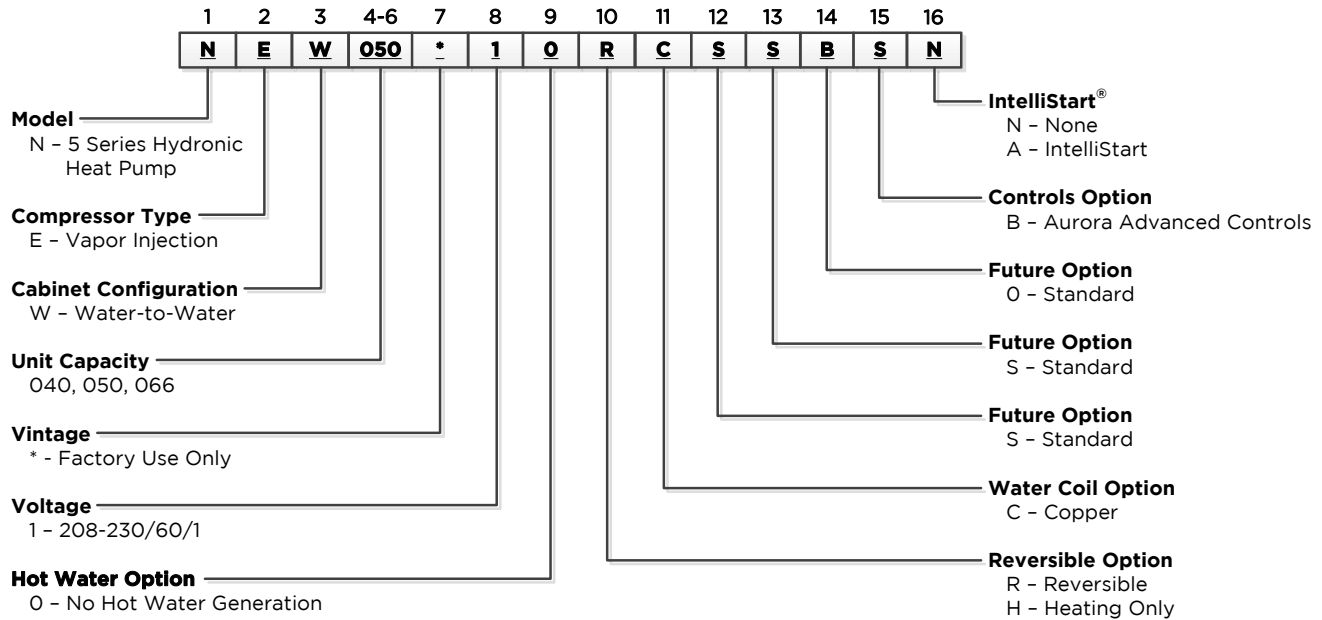

Rev.: 06 August 2014D

Voltage	NEW		
	040	050	066
208-230/60/1	••	•	•

- - Voltage available in this size
- - Voltage and soft start available in this size



All 5 Series product safety listed under UL1995 thru ETL and performance listed with AHRI in accordance with standard 13256-1. The 5 Series is also ENERGY STAR® rated.

## General Installation Information

### Safety Considerations

Installing and servicing air conditioning and heating equipment can be hazardous due to system pressure and electrical components. Only trained and qualified service personnel should install, repair or service heating and air conditioning equipment. When working on heating and air conditioning equipment, observe precautions in the literature, tags and labels attached to the unit and other safety precautions that may apply.

Follow all safety codes. Wear safety glasses and work gloves. Use quenching cloth for brazing operations. Have fire extinguisher available for all brazing operations.

**NOTE:** Before installing, check voltage of unit(s) to ensure proper voltage.



**WARNING: Before performing service or maintenance operations on the system, turn off main power switches to the unit. Electrical shock could cause serious personal injury.**



**WARNING: This heat pump is capable of producing hot water up to 150°F. All exposed piping surfaces shall be insulated to prevent serious personal injury that can occur from touching water piping.**

### Application

Units are not intended for heating domestic (potable) water or swimming pools by direct coupling. If used for this type of application, a secondary heat exchanger must be used.

### Moving and Storage

Move units in the normal "Up" orientation as indicated by the labels on the unit packaging. When the equipment is received, all items should be carefully checked against the bill of lading to ensure that all crates and cartons have been received in good condition. Examine units for shipping damage, removing unit packaging if necessary to properly inspect unit. Units in question should also be internally inspected. If any damage is observed, the carrier should make the proper notation on delivery receipt acknowledging the damage. Units are to be stored in a location that provides adequate protection from dirt, debris and moisture.



**WARNING: To avoid equipment damage, do not leave the system filled in a building without heat during cold weather, unless adequate freeze protection levels of antifreeze are used. Heat exchangers do not fully drain and will freeze unless protected, causing permanent damage.**

### Unit Location

Provide sufficient room to make water and electrical connections. If the unit is located in a confined space, provisions must be made for unit servicing. Locate the unit in an indoor area that allows easy removal of the access panels and has enough space for service personnel to perform maintenance or repair. These units are not approved for outdoor installation and, therefore, must be installed inside the structure being conditioned. Do not locate units in areas subject to freezing conditions.



**WARNING: Do not store or install units in corrosive environments or in locations subject to temperature or humidity extremes (e.g. attics, garages, rooftops, etc.). Corrosive conditions and high temperature or humidity can significantly reduce performance, reliability, and service life.**

### Mounting Units

Prior to setting the unit in place, remove and discard both compressor hold down shipping bolts located at the front of each compressor mounting bracket. Units should be mounted level on a vibration absorbing pad slightly larger than the base to provide isolation between the unit and the floor. It is not necessary to anchor the unit to the floor. Allow access to the front, back, top and side access panels for servicing.

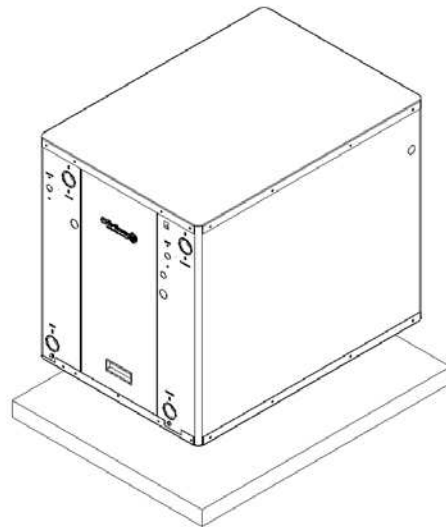

**Vibration Pad Mounting**

## Field Connected Water Piping

### General

Each unit is equipped with captive FPT water connections to eliminate 'egg-shaping' from use of a backup wrench. For making the water connections to the unit, a Teflon tape thread sealant is recommended to minimize internal fouling of the piping. Do not over tighten connections. All supply and return water piping should be insulated to prevent excess condensation from forming on the water lines.

**NOTE: Units are factory run-tested using propylene glycol. Prior to connecting piping to unit, thoroughly flush heat exchangers.**

The piping installation should provide service personnel with the ability to measure water temperatures and pressures. The water lines should be routed so as not to interfere with access to the unit. The use of a short length of high pressure hose with a swivel type fitting may simplify the connections and prevent vibration. Optional stainless steel hose kits are available as an accessory item.

Before final connection to the unit, the supply and return hose kits must be connected, and the system flushed to remove dirt, piping chips and other foreign material. Normally, a combination balancing and close-off (ball) valve is installed at the return, and a rated gate or ball valve is installed at the supply. The return valve can be adjusted to obtain the proper water flow. The valves allow the unit to be removed for servicing.

The proper water flow must be delivered to each unit whenever the unit heats or cools. To assure proper flow, the use of pressure/temperature ports is recommended to determine the flow rate. These ports should be located adjacent to the supply and return connections on the unit.

The proper flow rate cannot be accurately set without measuring the water pressure drop through the refrigerant-to-water heat exchanger (See Pressure Drop Table for water flow and pressure drop information). Normally about 3 GPM flow rate per ton of cooling capacity (2.25 GPM per ton minimum) is needed. Both source as well as load fluid piping must be at least as large as the unit connections on the heat pump (larger on long runs).

Never use flexible hoses of a smaller inside diameter than that of the water connection on the unit and limit hose length to 10 ft. per connection. Check carefully for water leaks.



**CAUTION: Water piping exposed to outside temperature may be subject to freezing.**

### Open Loop Well Water Systems

Always maintain water pressure in the heat exchanger by placing water control valves at the outlet of the unit. Use a closed bladder type expansion tank to minimize mineral deposits. Ensure proper water flow through the unit by checking pressure drop across the heat exchanger and comparing it to the figures in the pressure drop table. Normally, about 2 GPM flow rate per ton of cooling capacity is needed in open loop systems, (1.5 GPM per ton minimum if entering source temperature is above 50°F [10°C]).

Some water control valves draw their power directly from the unit's 24V transformer and can overload and possibly burn out the transformer. Check total VA draw of the water valve(s) and ensure it is under 40 VA.

Discharge water from a heat pump can be disposed of in various ways depending on local building codes (i.e. recharge well, storm sewer, drain field, adjacent stream or pond, etc.). Most local codes restrict the use of sanitary sewer for disposal. Consult your local building and zoning departments to ensure compliance in your area.

### Typical Open Loop Installation

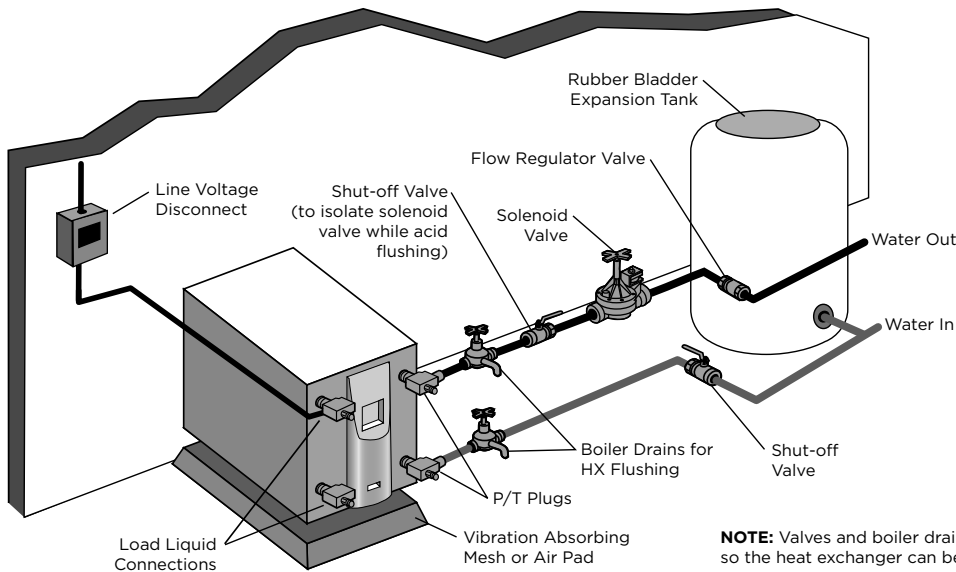

**NOTE: Valves and boiler drains must be installed so the heat exchanger can be acid flushed.**

## Field Connected Water Piping cont.

### Earth Coupled Systems with Flow Center

Once piping is completed between the unit, flow center and the earth loop, final purging and charging of the loop is needed. A flush cart (at least a 1.5 HP or 1.12 kW pump) is needed to achieve adequate flow velocity in the loop to purge air and dirt particles from the loop itself. Antifreeze solution is used in most areas to prevent freezing. Maintain the pH in the 7.6-8.2 range for final charging.

Flush the system adequately to remove as much air as possible. Then, pressurize the loop to a static pressure of 50-75 psi [345-517 kPa]. This is normally adequate for good system operation. Ensure that the flow center provides adequate flow through the unit by checking pressure drop across the heat exchanger and by comparing it to the figures shown in the Pressure Drop tables. Usually, 3 GPM/ton [0.054 L/s/kW] L/s/kW or minimum 2.25 GPM/ton [0.04 L/s/kW] of cooling capacity is needed in closed loop earth-coupled applications

### Typical Closed Loop Earth Coupled Installation

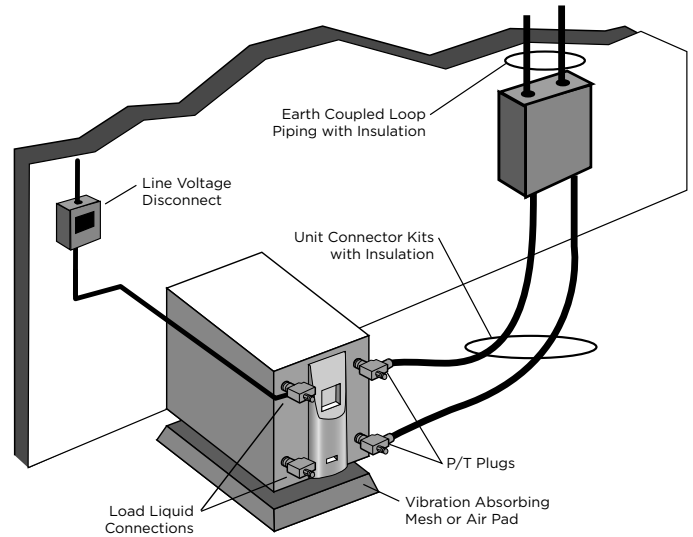

## Hydronic Section

General guidelines are shown below for component selection and design/installation criteria for the piping system. Local codes supersede any recommendations in this manual.

### Shut Off/Flow Regulation Valves

Use full port ball valves or gate valves for component isolation. If valves are going to be used frequently, ball valves are recommended. Globe valves are designed for flow regulation. Always install globe valves in the correct direction (fluid should enter through the lower body chamber).

### Check valves

Swing check valves must be installed in the horizontal position with the bonnet of the valve upright. Spring check valves can be mounted in any position. A flow check valve is required to prevent thermo-siphoning (or gravity flow) when the circulator pump is off or when there are two circulators on the same system.

### Storage (Buffer) Tank

A buffer tank is required for all hydronic heating systems using 504W11 5 Series OptiHeat heat pumps. The tank should be sized to provide 2 gallons of storage capacity for every one thousand Btuh's of nominal heat pump capacity.

### Pressure Relief Valve

Most codes require the use of a pressure relief valve if a closed loop heat source can be isolated by valves. Even if local code does not require this device, WaterFurnace recommends its installation. If the pressure relief valve in the buffer tank is not already rated at 30 psi (207 kPa) maximum pressure, one must be installed. The pressure relief valve should be tested at start up for operation. Note that the waste pipe must be at least the same diameter as the valve outlet (never reduce), and valves may not be added to this pipe. The bottom of the pipe must terminate at least 6" (15 cm) above the floor. If the piping is connected to a drain, there must be an air gap.

### Backflow Prevention Check Valves

Most codes require backflow prevention check valves. Note that a single check valve is not equal to a backflow prevention check valve. Even if local code does not require this device, WaterFurnace recommends its installation. This is particularly important if the system will use antifreeze.

### Pressure Reducing Valves or Feed Water Valves

This valve lowers the pressure from the make-up water line to the system. Most are adjustable and directional. A "fast fill" valve is required for initial filling of the system. Some have screens, which must be cleaned after the initial filling. If there is a restriction in the screen, the system could go to

0 psi (0 kPa), potentially causing pumps(s) failure. A valve should be installed on each side of the pressure reducing valve for servicing. Both valves should have tags reading "Do not shut this valve under normal operation - service valve only."

### Expansion Tanks

Expansion tanks are required on hydronic systems to help absorb the pressure swings as the temperature in the system fluctuates.

### Elbows/Tees

Long radius elbows or two 45° elbows will lower pressure drop. Standard tees have a greater restriction on the "T" portion than tees designed with angled outlet ports.

### Antifreeze

Antifreeze is required if any of the piping system is located in areas subject to freezing.

### Dielectric Unions

Dielectric unions are recommended whenever connecting two dissimilar metals together to prevent electro-galvanic corrosion.

When using the various types of hydronic heat distribution systems, the temperature limits of the geothermal system must be a major consideration. In new construction, the distribution system can easily be designed with the temperature limits in mind. In retrofits, care must be taken to address the operating temperature limits of the existing distribution system. The maximum storage tank temperature for the 504W11 5 Series OptiHeat is 150°F (65°C). Typical in floor radiant systems require much lower temperatures, typically 100°-115°F, which is ideal for the 504W11 5 Series OptiHeat.

Open the screw 2 turns only in the end of the pump motor (if Grundfos® pumps are used) to allow trapped air to be discharged and to ensure the motor housing has been flooded.



## Hydronic Section cont.

If using a Geothermal Storage tank there will be two red wires exiting out the top of the tank. These red wires extend internally down to the thermistor/tank thermostat section of the tank. Remove the bottom tank control cover to expose the red wires as well as the yellow tank thermistor wires. If using HydroZone control, connect the two red wires to the two yellow wires using wire nuts. Next, connect the two red wires from the top of the Geothermal Storage tank to "TS" and "GND" on the HydroZone. For other field installed controllers, these two red wires will need wired to the appropriate sensor input terminals. Another option for connection is to connect the thermostat on the Geothermal Storage tank directly to "R" and "Y1" on the ABC board.

Adequate rate of flow (GPM) is very important to system performance and long term reliability. Follow the guidelines for recommended flow in the 504W11 OptiHeat recommendations table.

### WaterFurnace Geothermal Storage Tank Thermostat and Thermistor

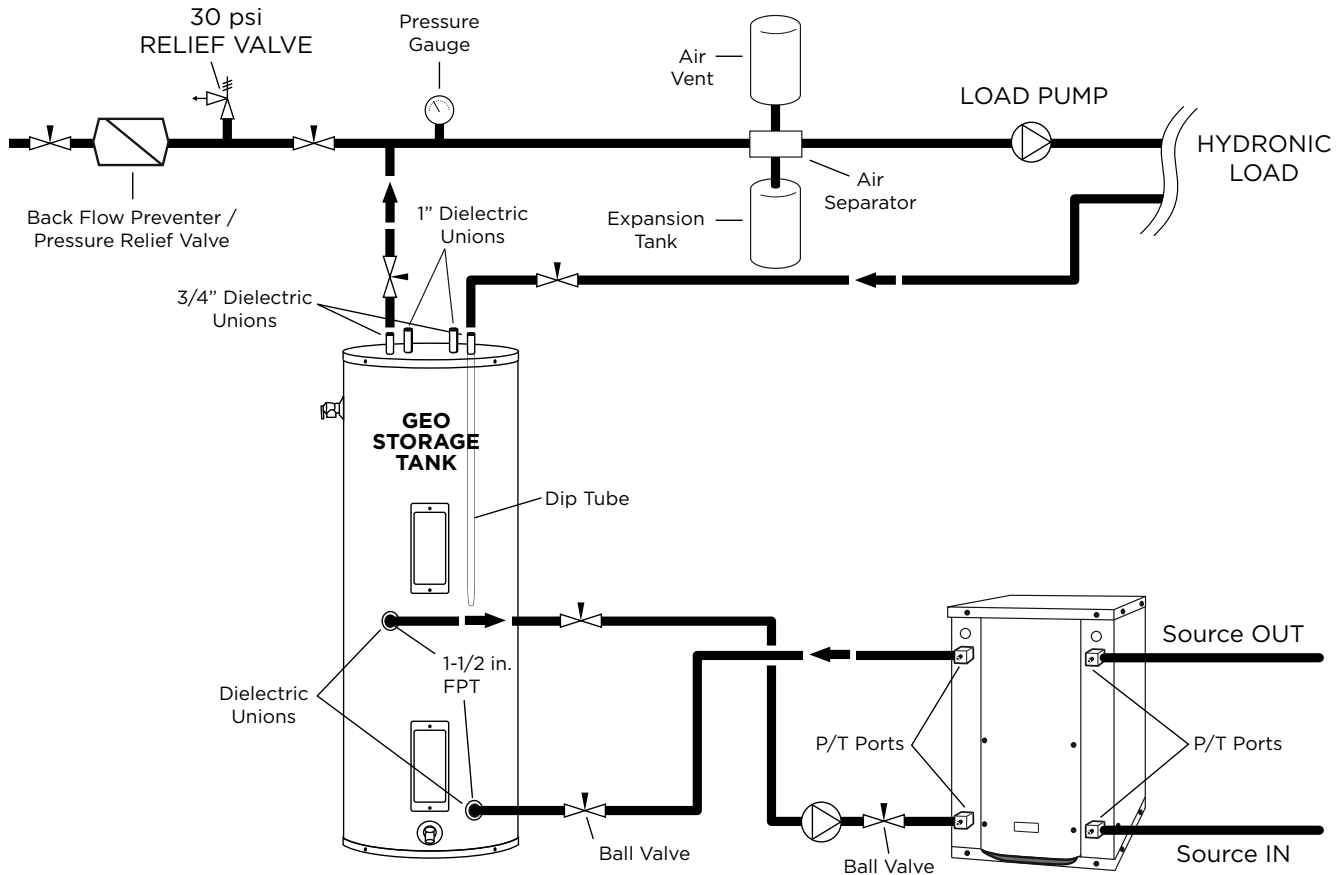
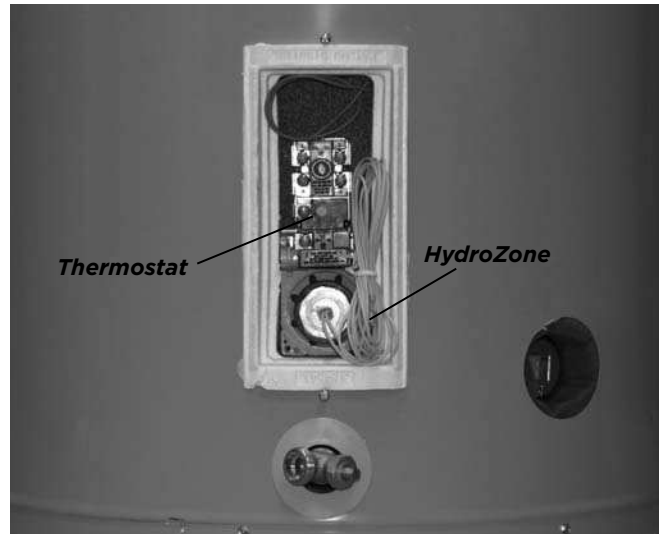

## Accessories and Options

### IntelliStart (Model 040 only)

IntelliStart is a single phase compressor soft starter which reduces the normal start current (LRA) by 60-70%. It should be used in applications that require low starting amps, reduced compressor start-up noise, off-grid, and improved start-up behavior. IntelliStart is available as a factory installed option or a field installed kit. IntelliStart is available on 208-230/60/1 voltage.

### Water Connection Kits (Field Installed)

Water connection kits are available to facilitate loop side and load side water connections.

- **MA4FPT** - Forged brass 1" MPT x 1" FPT square street elbow with P/T plug for NEW040 water side connections
- **MA5FPT** - Forged brass 1.25" MPT x 1.25" FPT square street elbow with P/T plug for NEW050-NEW066 water side connections
- **2-HVAC-1x24** - 1 inch x 24 inch stainless steel braided hose kit
- **2-HVAC-1 1/4x24** - 1 1/4 inch x 24 inch stainless steel braided hose kit

### Earth Loop Pump Kit (Field Installed)

A specially designed one or two-pump module provides all liquid flow, fill and connection requirements for independent single unit systems (230/60/1 only). The one-pump module (FC1-FPT or FC1-GL) is capable of 25 feet of head at 12.0 GPM, while the two-pump module (FC2-FPT or FC1-GL) is capable of 50 feet of head at 12.0 GPM.

### Load-side Pump Kit (Field Installed)

Four (4) load pump kits are available to provide all liquid flow requirements for independent single unit systems (230/60/1 only). WaterFurnace part number **24S516-10** (Grundfos UPS15-42RU) is a composite body pump. **EWPK2** (Grundfos UP26-64BF) is bronze body pump. WaterFurnace part number EWPK1 and EWPK3 come with a cast iron body pump (Grundfos UP26-99F) that can be used for hydronic heating applications.

Calculate the system pressure drop then refer to the pump curves in figure 8 to select the proper pump. All four (4) of the WaterFurnace pump kits can be used for hydronic heating applications as long as they meet the flow requirements. If the flow requirements are outside the pump curve, an alternate pump will need to be obtained to maintain the necessary flow.

- **24S516-10** - UPS15-42RU composite PPS, 3/4 inch union sweat connection
- **EWPK1** - UP26-99F cast iron volute, 1 inch FPT flange connection
- **EWPK2** - UP26-64BF bronze volute, 1 inch FPT flange connection
- **EWPK3** - UP26-99F cast iron volute, 1-1/4 inch FPT flange connection

### HydroZone Tank Controller

Tank controller (**HZC**) that adds outdoor reset with warm weather shutdown, setpoint control, process control, and management of four compressor outputs for our water-to-water systems.

### HZAB

This is used in conjunction with the HydroZone to control the Geo-Storage tank electric heating element.

**Figure 8:** UP26-64BF and UP26-99F Single and Two Pump Curve

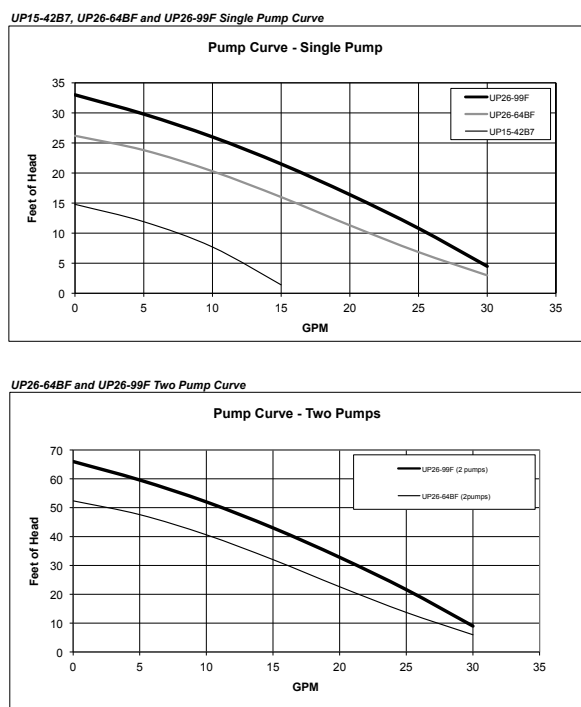

## Accessories and Options cont.

### Geo Storage Tank Dimensions

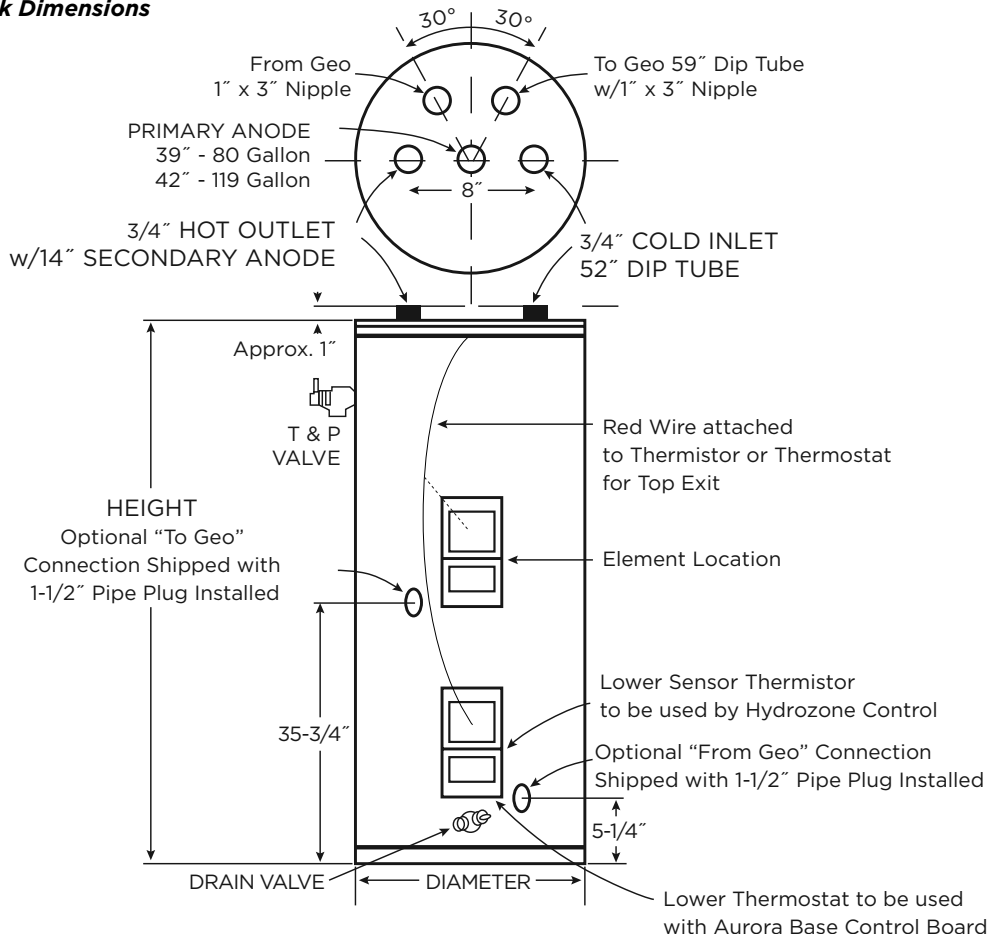

MODEL NUMBER	GALLON CAPACITY	ELEMENT WATTAGE (240 VOLT)	NUMBER OF ELEMENTS	R VALUE	DIMENSIONS IN INCHES		APPROX. SHIPPING WEIGHT (lbs.)
					HEIGHT	DIAMETER	
GEO-STORAGE-80	80	4500	1	16	63-1/4	24	204
GEO-STORAGE-120	119	4500	1	16	63-1/4	28	311

## Electrical Data

Model	Rated Voltage	Voltage Min/Max	Compressor				Load Pump	Source Pump	Total Unit FLA	Min Ckt Amp	Maximum Fuse/HACR
			MCC	RLA	LRA	LRA*					
<b>040</b>	208-230/60/1	198/254	27.7	17.8	135.0	47.0	1.8	5.4	25.0	29.5	45
<b>050</b>	208-230/60/1	198/254	37.8	24.2	178.0	-	1.8	5.4	31.4	37.5	60
<b>066</b>	208-230/60/1	198/254	40.3	25.8	178.0	-	1.8	5.4	33.0	39.5	60

Notes: All fuses type "D" time delay (or HACR circuit breaker in USA).  
 Source pump amps shown are for up to a 1/2 HP pump  
 Load pump amps shown are for small circulators.  
 \*LRA with IntelliStart installed

7/08/14

### 504W11 OptiHeat Control Box

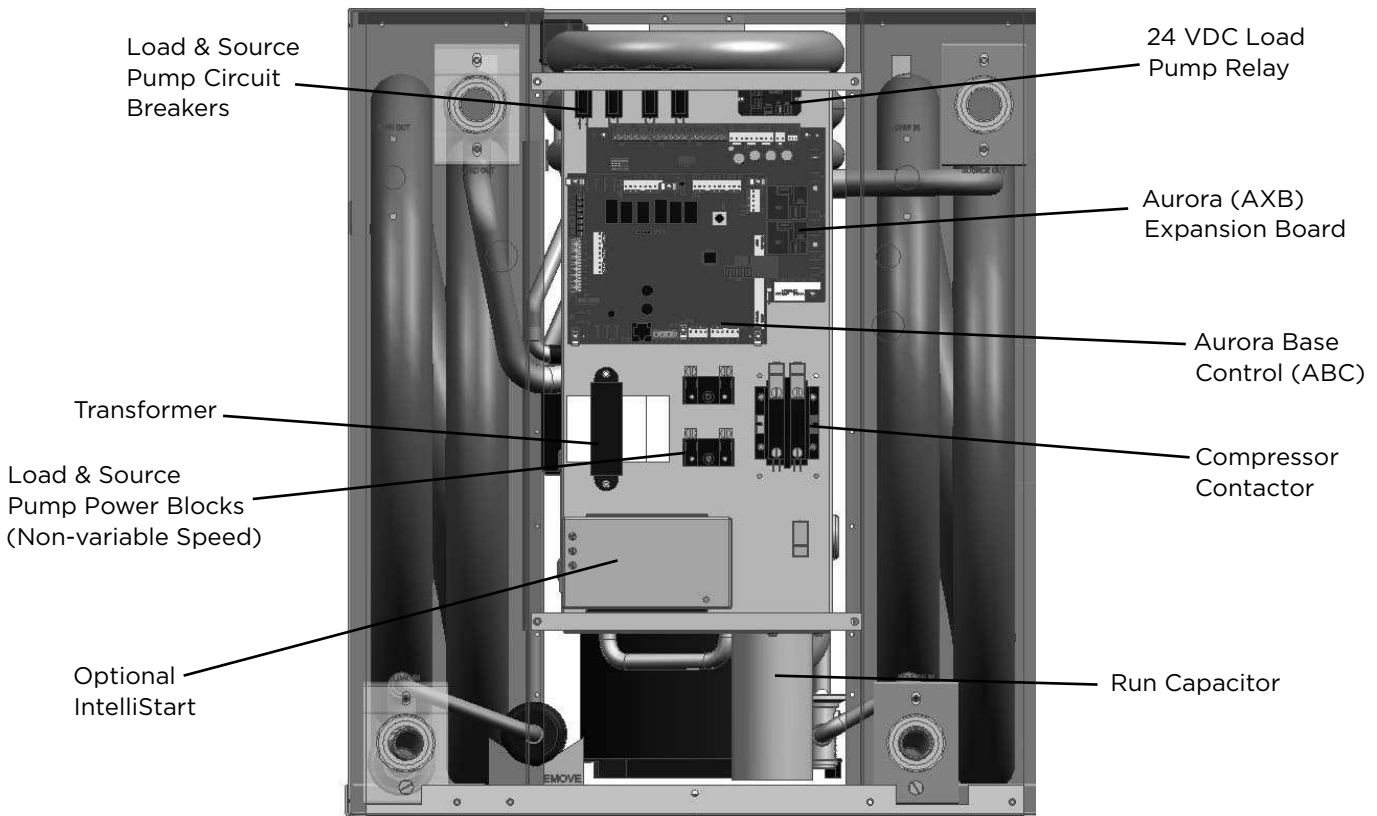

## Electrical Data cont.

### 208 Volt Operation

All 208-230 volt units are factory wired for 230 volt operation. To convert the unit from a 230V unit to a 208V unit follow these steps:

1. Remove the blue transformer wire from terminal L2 on the compressor contactor and secure the wire taking care to insulate the end with electrical tape.
2. Locate the red transformer wire and connect it to the L2 terminal of the compressor contactor.

### Electrical

Be sure the available power is the same voltage and phase as that shown on the unit serial plate. Line and low voltage wiring must be done in accordance with local codes or the National Electric Code, whichever is applicable. Refer to the Electrical Data table for wire and fuse or circuit breaker sizing information.

### Flow Center Pump Connection (208-230/60/1)

Two internal terminal block connections with 1/4-inch spade connectors are provided; one for the load pump and one for the source pump. The source pump directly connects to the 5A circuit breakers for the source pump. The load pump directly connects to the 5A circuit breakers for the load pump. This section is not used for variable speed pumps.

### 5 Series 504W11 OptiHeat Control Box Relocation

The 5 Series 504W11 control box can be installed on the rear of the unit. To relocate the control box, follow the procedures below.

1. Remove all power sources to the unit.
2. Remove the unit's top panel.
3. Cut all plastic wire ties to the following:
  - a) High pressure switch (black wires)
  - b) Low pressure switch (blue wires)
  - c) Freeze sensing
  - d) Load temperature sensor
  - e) Compressor wires
4. Remove the four screws from the control box.
5. Relocate the control box to opposite end of the unit.
6. Using the screws removed in step 4 above, reattach the control box.
7. Secure all wires so they do not come in contact with refrigerant lines.
8. Replace the top of the unit.
9. Replace both access panels.
10. Reapply power sources.

## Unit Startup

### Before Powering Unit

Check the following:

- High voltage wiring is correct and matches the nameplate.
- Fuses, breakers and wire size are correct.
- Piping is completed and water system has been cleaned and flushed.
- Air is purged from the closed loop system.
- Isolation valves are open and loop water control valves or loop pumps are wired.
- Service/access panels are in place.

# Wiring Schematics

## Aurora Advanced EVI Water-Water 208-230/60/1

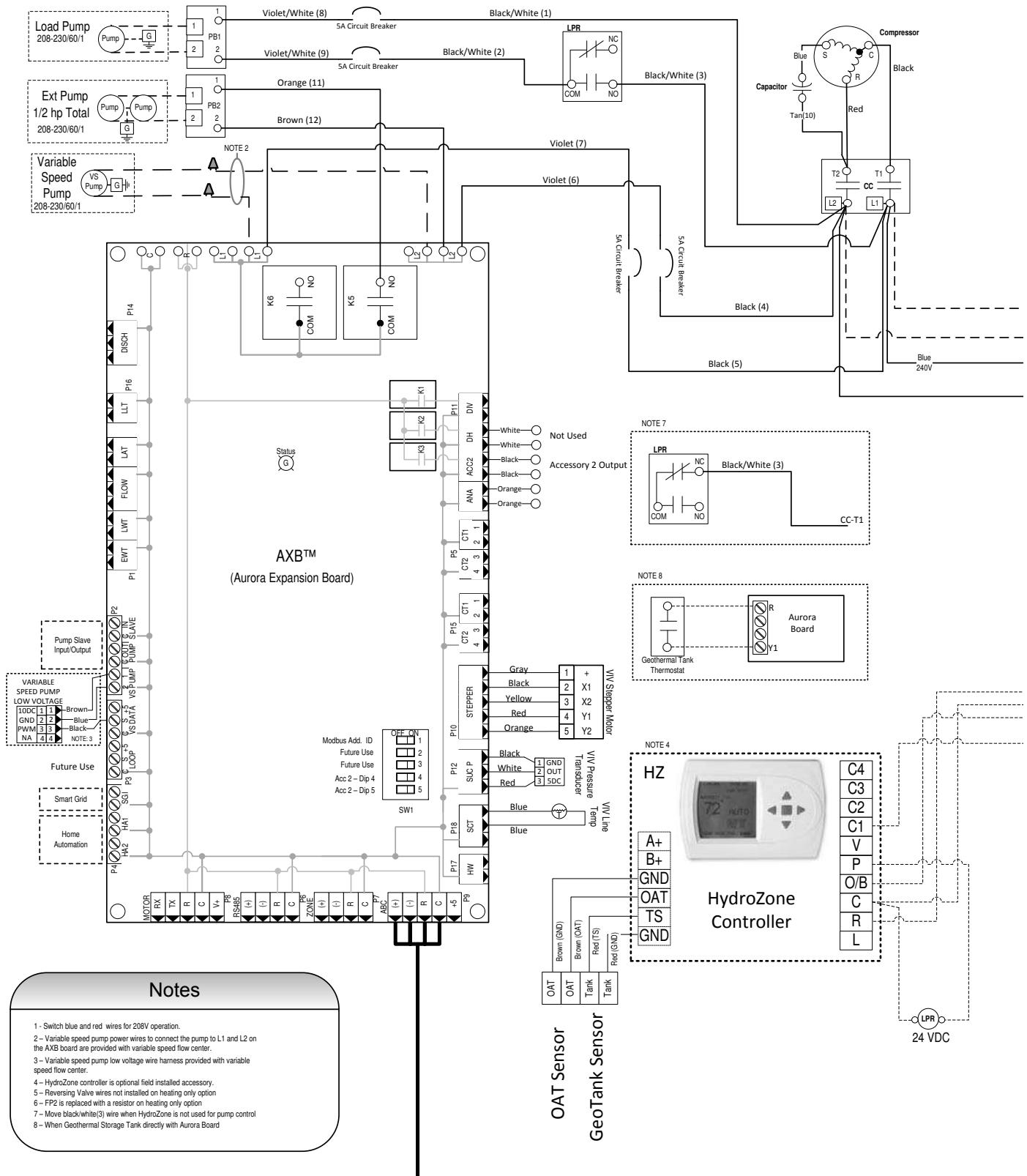

# Wiring Schematics cont.

## Aurora Advanced EVI Water-Water 208-230/60/1

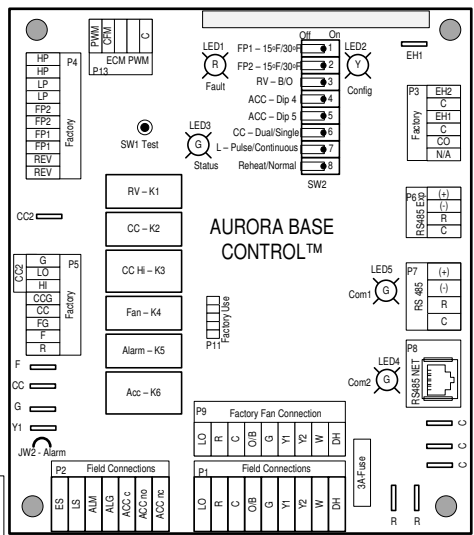
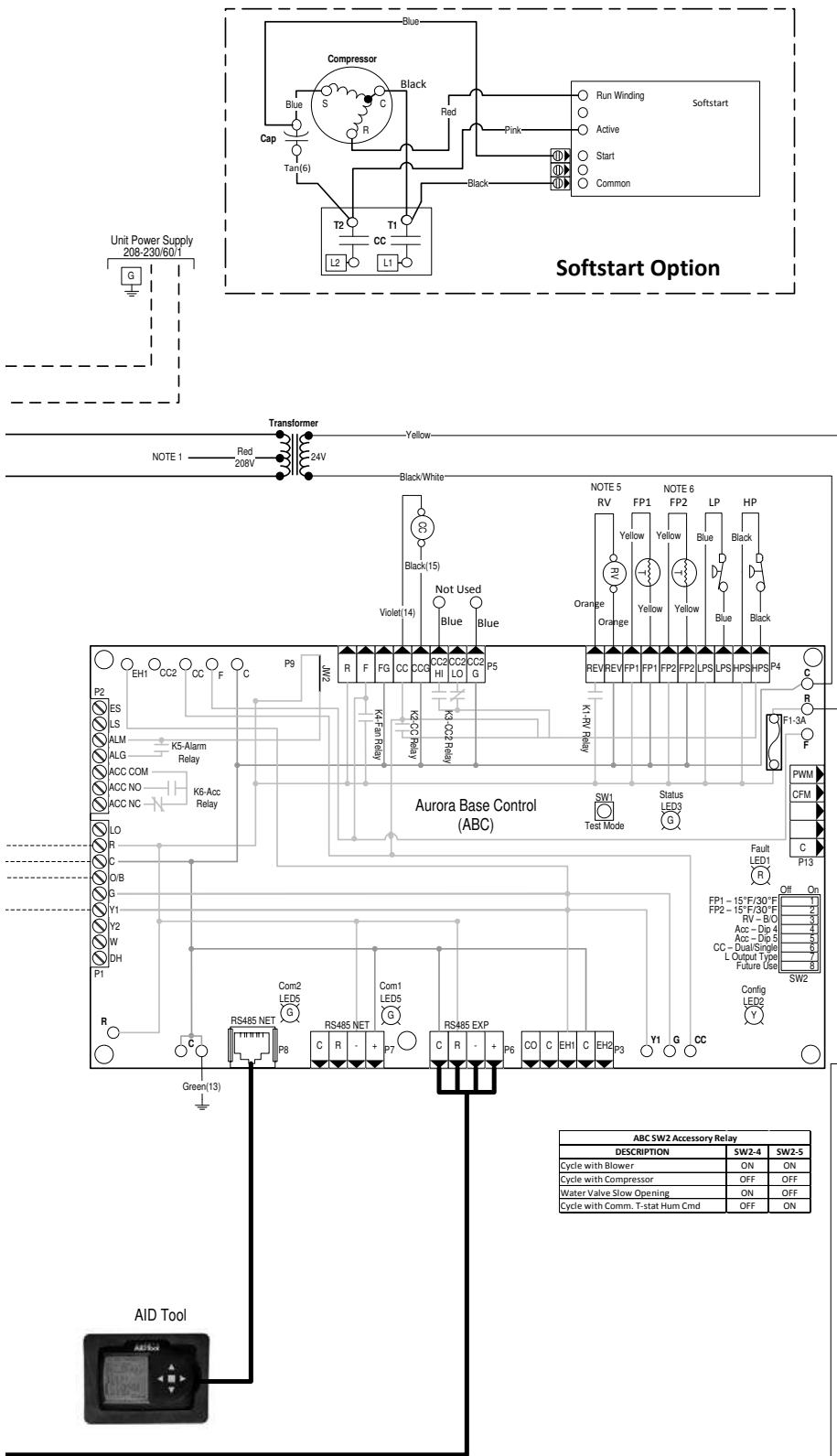

**Aurora LED Flash Codes**

Slow Flash	1 second on and 1 second off
<b>Fast Flash</b>	100 milliseconds on and 100 milliseconds off
<b>Flash Code</b>	100 milliseconds on and 400 milliseconds off with a 2 second pause before repeating
<b>Random Start Delay (Alternating Colors)</b>	<b>Configuration LED (LED2, Yellow)</b>
Status LED (LED1, Green)	Fast Flash No Software Override OFF
Configuration LED (LED2, Yellow)	Fast Flash DIP Switch Override Slow Flash
Fault LED (LED3, Red)	Fast Flash

Normal Mode	OFF	Normal Mode	ON
Input Fault Lockout	Flash Code 1	Control is Non-Functional	Slow Flash
High Pressure Lockout	Flash Code 2	Test Mode	Off Flash
Low Pressure Lockout	Flash Code 3	Lockout Active	Fast Flash
Future Use	Flash Code 4	Dehumidification Mode	Flash Code 2
Freeze Detection - FP1	Flash Code 5	Future Use	Flash Code 3
Reserved	Flash Code 6	Future Use	Flash Code 4
Condensate Overflow Lockout	Flash Code 7	Load Shed	Flash Code 5
Over/Under Voltage Shutdown	Flash Code 8	ESD	Flash Code 6
Future Use	Flash Code 9	Future Use	Flash Code 7
Future Use	Flash Code 10		
FP1 and FP2 Sensor Error	Flash Code 11		

**Aurora Timing Events**

Event	Normal Mode	Test Mode
Random Start Delay	5 to 80 seconds	1 second
Compressor On Delay	5 seconds	< 1 second
Compressor Minimum On Time	2 minutes	5 seconds
Compressor Short Cycle Delay	4 minutes	15 seconds
Fault Recognition Delay - High Pressure	Less than 1 second	Less than 1 second
Start-Up Bypass - Low Pressure	2 minutes	30 seconds
Fault Recognition Delay - Low Pressure	30 seconds	30 seconds
Start-Up Bypass - Low Water Coil Limit	2 minutes	30 seconds
Fault Recognition Delay - Low Water Coil Limit	30 seconds	30 seconds
Fault Recognition Delay - Condensate Overflow	30 seconds	30 seconds
HydroZone Call Recognition Time	2 seconds	2 seconds
Water Valve Slow Open Delay	90 seconds	90 seconds

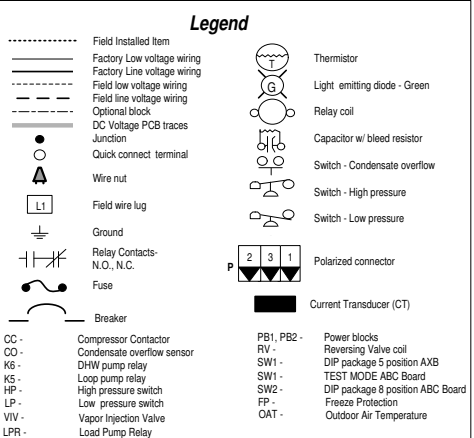

## The Aurora ‘Base’ Control System

### Aurora ‘Base’ Control

The Aurora ‘Base’ Control (ABC) System is a complete residential and commercial comfort system that brings all aspects of the HVAC system into one cohesive module network. The ABC features microprocessor control and HP, LP, freeze detection, over/under voltage faults.

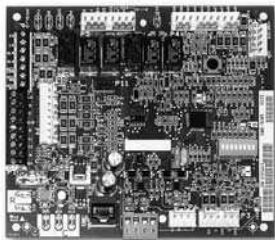

Aurora uses the Modbus communication protocol to communicate between modules. Each module contains the logic to control all features that are connected to the module. The Aurora ‘Base’ Control (ABC) has two Modbus channels. The first channel is configured as a master for connecting to devices such as an expansion board, or other slave devices. The second channel is configured as a slave for connecting the Aurora Interface Diagnostics Tool (AID Tool).

### Aurora ‘Advanced’ Control

The Aurora ‘Advanced’ Control expands on the capability of the Aurora ‘Base’ Control (ABC) System by adding the Aurora Expansion Board (AXB). The additional features include loop pump slaving and variable speed pump capability. The AXB also features a second field configurable accessory relay, and two home automation inputs that are AID configurable for different types of alarms from sump pumps to home security. The Smart Grid input is AID configurable with many options to react to Utility controlled relay operation for ON Peak optimization.

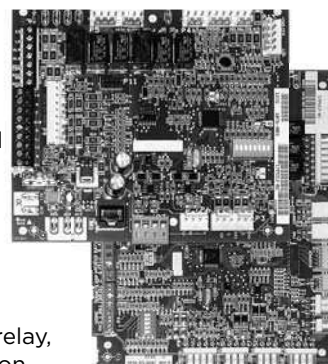

Aurora Control Features	Description	Aurora ‘Advanced’
<b>Microprocessor Compressor Control</b>	Microprocessor control of compressor for timings with FP1, HP, LP, Condensate, assignable Acc relay	•
<b>Advanced Microprocessor Features</b>	Smart Grid, Home Automation Alarm Inputs, and Accessory2 Relay (HRV/ERV)	•
<b>Advanced Speed Pump Control</b>	Microprocessor and separate power relay for loop pump and inline circuit breakers and loop pump slaving.	•
<b>Variable Speed Pump</b>	Capable of setup, monitoring and controlling a variable speed flow center.	•
<b>Smart Grid/Utility Input</b>	Allows simple input to externally enable of occupied/unoccupied mode for basic utility time of use programs.	Dry Contact x1
<b>Home Automation Alarm Input</b>	Allows simple input to signal sump, security, or smoke/CO sensor alarms from other home automation or security systems. The two inputs can be field configured to a number of options and logic.	Dry Contactx2
<b>HAN/Smart Grid Com (AWL and Portal) Kit</b>	Allows direct communication of the Aurora to Smart Meters, Home Automation Network and Internet.	Optional AWL

Service Device	Description	Aurora ‘Base’	Aurora ‘Advanced’
 <p><b>Aurora Interface and Diagnostics (AID) Tool</b></p>	Allows setup, monitoring and troubleshooting of any Aurora Control.  <b>NOTE:</b> Although the ABC has basic compatibility with all Aurora, new product features may not be available on older AID Tools. To simplify the basic compatibility ensure the version of AID is at least the same or greater than the ABC software version.	For Service (Ver. 1.xx or greater)	For Service (Ver. 2.xx or greater)



## The Aurora 'Base' Control System cont.

### Aurora 'Base' Control

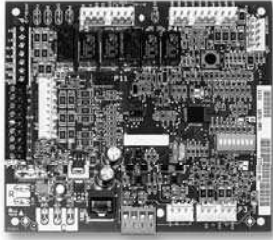

**NOTE:** Refer to the Aurora Base Control Application and Troubleshooting Guide and the Instruction Guide: Aurora Interface and Diagnostics (AID) Tool for additional information.

### Control Features

- Random start at power up
- Anti-short cycle protection
- High and low pressure cutouts
- Loss of charge
- Water coil freeze detection
- Over/under voltage protection
- Load shed
- Emergency shutdown
- Diagnostic LED
- Test mode push button switch
- Alarm output
- Accessory output with N.O. and N.C.
- Modbus communication (master)
- Modbus communication (slave)

### Field Selectable Options via Hardware

**DIP Switch (SW1)** – Test/Configuration Button (See SW1 Operation Table)

#### Test Mode

The control is placed in the test mode by holding the push button switch SW1 for 2 - 5 seconds. In test mode most of the control timings will be shortened by a factor of sixteen (16). LED3 (green) will flash at 1 second on and 1 second off. Additionally, when entering test mode LED1 (red) will flash the last lockout one time. Test mode will automatically time out after 30 minutes. Test mode can be exited by pressing and holding the SW1 button for 2 to 5 seconds or by cycling the power. **NOTE:** Test mode will automatically be exited after 30 minutes.

#### Reset Configuration Mode

The control is placed in reset configuration mode by holding the push button switch SW1 for 50 to 60 seconds. This will reset all configuration settings and the EEPROM back to the factory default settings. LED3 (green) will turn off when entering reset configuration mode. Once LED3 (green) turns off, release SW1 and the control will reset.

#### DIP Switch (SW2)

**SW2-1 (Source)** FP1 Selection – Low water coil temperature limit setting for freeze detection. On = 30°F; Off = 15°F.

**SW2-2 (Load)** FP2 Selection – On = 30°F; Off = 15°F

**SW2-3** RV – O/B - thermostat type. Heat pump thermostats with “O” output in cooling or “B” output in Heating can be selected. On = O; Off = B.

**SW2-4** Access Relay Operation (P2) and 2-5

Access Relay Operation	SW2-4	SW2-5
Cycle with Blower		n/a
Cycle with Compressor	OFF	OFF
Water Valve Slow Opening	ON	OFF
Cycle with Comm. T-stat Hum Cmd		n/a

**Cycle with Blower** - (Not used on water-to-water)

**Cycle with Compressor** - The accessory relay will cycle with the compressor output.

**Water Valve Slow Opening** - The accessory relay will cycle and delay both the blower and compressor output for 90 seconds.

**SW2-6** CC Operation – selection of single or dual capacity compressor. On = Single Stage; Off = Dual Capacity

**SW2-7** Lockout and Alarm Outputs (P2) – selection of a continuous or pulsed output for both the LO and ALM Outputs. On = Continuous; Off = Pulsed

**SW2-8** *Future Use*

#### Alarm Jumper Clip Selection

From the factory, ALM is connected to 24 VAC via JW2. By cutting JW2, ALM becomes a dry contact connected to ALG.

### Field Selectable Options via Software

(Selectable via the Aurora AID Tool)

### Safety Features

The following safety features are provided to protect the compressor, heat exchangers, wiring and other components from damage caused by operation outside of design conditions.

**Fuse** – a 3 amp automotive type plug-in fuse provides protection against short circuit or overload conditions.

**Anti-Short Cycle Protection** – 4 minute anti-short cycle protection for the compressor.

**Random Start** – 5 to 80 second random start upon power up.

## The Aurora 'Base' Control System cont.

**Fault Retry** - in the fault condition, the control will stage off the outputs and then "try again" to satisfy the thermostat Y input call. Once the thermostat input calls are satisfied, the control will continue on as if no fault occurred. If 3 consecutive faults occur without satisfying the thermostat Y input call, then the control will go to Lockout mode.

**Lockout** - The Alarm output (ALM) and Lockout output (L) will be turned on. The fault type identification display LED1 (Red) shall flash the fault code. To reset lockout conditions with SW2-8 On, thermostat inputs "Y1", "Y2", and "W" must be removed for at least 3 seconds. To reset lockout conditions with SW2-8 Off, thermostat inputs "Y1", "Y2", "W", and "DH" must be removed for at least 3 seconds. Lockout may also be reset by turning power off for at least 30 seconds or by enabling the emergency shutdown input for at least 3 seconds.

**High Pressure** - fault is recognized when the Normally Closed High Pressure Switch, P4-9/10 opens, no matter how momentarily. The High Pressure Switch is electrically in series with the Compressor Contactor and serves as a hard-wired limit switch if an overpressure condition should occur.

**Low Pressure** - fault is recognized when the Normally Closed Low Pressure Switch, P4-7/8 is continuously open for 30 seconds. Closure of the LPS any time during the 30 second recognition time restarts the 30 second continuous open requirement. A continuously open LPS shall not be recognized during the 2 minute startup bypass time.

**Loss of Charge** - fault is recognized when the Normally Closed Low Pressure Switch, P4-7/8 is open prior to the compressor starting.

**Freeze Detection (Source Coax)** - set points shall be either 30°F or 15°F. When the thermistor temperature drops below the selected set point, the control shall begin counting down the 30 seconds delay. If the thermistor value rises above the selected set point, then the count should reset. The resistance value must remain below the selected set point for the entire length of the appropriate delay to be recognized as a fault. This fault will be ignored for the initial 2 minutes of the compressor run time.

**Freeze Detection (Load Coax)** - uses the FP2 input to protect against ice formation on the coax. The FP2 input will operate exactly like FP1.

**Over/Under Voltage Shutdown** - An over/under voltage condition exists when the control voltage is outside the range of 18 VAC to 30 VAC. If the over/under voltage shutdown lasts for 15 minutes, the lockout and alarm relay will be energized. Over/under voltage shutdown is self-resetting in that if the voltage comes back within range of 18 VAC to 30 VAC for at least 0.5 seconds, then normal operation is restored.

### Operation Description

**Power Up** - The unit will not operate until all the inputs and safety controls are checked for normal conditions. The unit has a 5 to 80 second random start delay at power up. Then the compressor has a 4 minute anti-short cycle delay after the random start delay.

**Standby** In standby mode, Y1, Y2, W, DH, and G are not active. Input O may be active. The blower and compressor will be off.

### Heating Operation

**Heating, 1st Stage (Y1)** - The compressor is energized 10 seconds after the Y1 input is received.

### Cooling Operation

In all cooling operations, the reversing valve directly tracks the O input. Thus, anytime the O input is present, the reversing valve will be energized.

**Cooling, 1st Stage (Y1, O)** - The compressor is energized 10 seconds after the Y1 input is received.

**Emergency Shutdown** - Four (4) seconds after a valid ES input, P2-7 is present, all control outputs will be turned off and remain off until the emergency shutdown input is no longer present. The first time that the compressor is started after the control exits the emergency shutdown mode, there will be an anti-short cycle delay followed by a random start delay. Input must be tied to common to activate.

**Load Shed** - The LS input disables all outputs with the exception of the blower output. When the LS input has been cleared, the anti-short cycle timer and random start timer will be initiated. Input must be tied to common to activate.

# The Aurora 'Base' Control System cont.

## Aurora 'Base' Control LED Displays

These three LEDs display the status, configuration, and fault codes for the control. These can also be read in plain English via the Aurora AID Tool.

### Status LED (LED3, Green)

Description of Operation	Fault LED, Green
Normal Mode	ON
Control is Non-functional	OFF
Test Mode	Slow Flash
Lockout Active	Fast Flash
Dehumidification Mode	Flash Code 2
(Future Use)	Flash Code 3
(Future Use)	Flash Code 4
Load Shed	Flash Code 5
ESD	Flash Code 6
(Future Use)	Flash Code 7

## Aurora Interface and Diagnostics (AID) Tool

The Aurora Interface and Diagnostics (AID) Tool is a device that is a member of the Aurora network. The AID Tool is used to troubleshoot equipment which uses the Aurora control via Modbus RTU communication.



The AID Tool provides diagnostics, fault management, ECM setup, and system configuration capabilities to the Aurora family of controls. An AID Tool is recommended, although not required, for ECM airflow settings. The AID Tool simply plugs into the exterior of the cabinet in the AID Tool port.

## ABC Control Board Layout

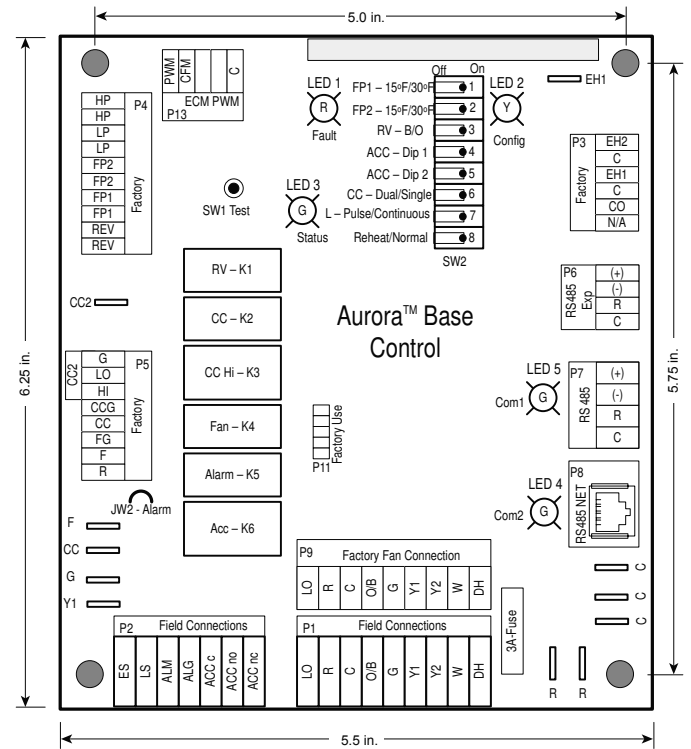

## The Aurora ‘Base’ Control System cont.

### Aurora ‘Advanced’ Control Features

The Aurora ‘Advanced’ Control system expands on the capability of the Aurora ‘Base’ Control (ABC) by adding the Aurora Expansion Board (AXB). All of the preceding features of the Aurora ‘Base’ Control are included. The following control description is of the additional features and capability of the Aurora advanced control.

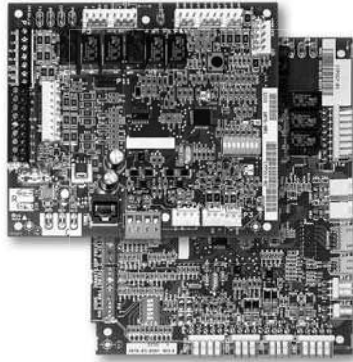

It is highly recommended the installing/servicing contractor obtain an Aurora Interface and Diagnostic Tool (AID) and specialized training before attempting to install or service an Aurora ‘Advanced’ control system.



The additional AXB features include the following:

#### AXB DIP Switch

**DIP 1 - ID:** This is the AXB ModBus ID and should always read On.

#### DIP 2 & 3 - Future Use

**DIP 4 & 5 - Accessory Relay2:** A second, DIP configurable, accessory relay is provided that can be cycled with the compressor 1 or 2 , blower, or the Dehumidifier (DH) input. This is to complement the Accessory 1 Relay on the ABC board.

Position	DIP 4	DIP 5	Description
1	ON	ON	Cycles with Fan or ECM (or G)
2	OFF	ON	Cycles with CC1 first stage of compressor or compressor spd 1-12
3	ON	OFF	Cycles with CC2 second stage of compressor or compressor spd 7-12
4	OFF	OFF	Cycles with DH input from ABC board

### Variable Speed Pump

This input and output are provided to drive and monitor a variable speed pump. The VS pump output is a PWM signal to drive the variable speed pump. The minimum and maximum level are set using the AID Tool. 75% and 100% are the default settings respectively. The VS data input allows a separate PWM signal to return from the pump giving fault and performance information. Fault received from the variable speed pump will be displayed as E16.

### Modulating Water Valve

This output is provided to drive a modulating water valve. Through advanced design the 0-10VDC valve can be driven directly from the VS pump output. The minimum and maximum level are set in the same way as the VS pump using the AID Tool. 75% and 100% are the default settings respectively.

### Loop Pump Slaving

This input and output are provided so that two units can be slaved together with a common flow center. When either unit has a call for loop pump, both unit’s loop pump relays and variable speed pumps are energized. The flow center then can simply be wired to either unit. The output from one unit should be routed to the input of the other. If daisy chained up to 16 heat pumps can be wired and slaved together in this fashion.

### Advanced Communication Ports

Communication ports P6 and P8 will provide future expansion via dedicated protocols. These are for future use.

### Smart Grid-On Peak (SG) Input

The ‘On Peak’ input was designed to allow utilities to utilize simple radio controlled switches to control the On Electric Peak behavior of the 5 and 7 Series Geothermal Heat Pumps. With a closed contact signal, this input will limit the operation and thus the power consumption of the unit by one of the below selections. The AID Tool will allow configuration of this input for the action of:

- No Action
- Disable compressor operation until removed
- Go to On Peak thermostat settings until removed [Requires Com T-Stat] (Future Release)
- Compressor limited to 50% or low cap until removed [dual capacity or variable speed only] (Future Release)
- Disable compressor operation for 1/2 hr (can be removed immediately) (Future Release)

Then Flash Code 7 on the Green LED for the ‘On Peak’ mode. And On Peak will display on communicating thermostats.

### Home Automation 1 and 2 Inputs

The Home automation inputs are simple closed contact inputs that will trigger an AID Tool and thermostat alert for the homeowner. These would require optional sensors and or equipment for connection to the AXB board. With two inputs two different sensors can be selected. The selected text will then be displayed on the AID Tool and communicating thermostats. These events will NOT alter functionality or operation of the heat pump/accessories and is for homeowner/service notification only.

## The Aurora ‘Base’ Control System cont.

### Home Automation 1 - E23 HA1

With a closed dry contact signal, this input will cause an alarm and Alert Code 23 to indicate on the stat or flash on ABC. The AID Tool will allow configuration of this input between the following selections:

- No Action
- Home Automation Fault [no lockout info only]
  - Output from home automation system
- Security Alarm [no lockout info only]
  - Output from home security
- Sump Alarm Fault [no lockout info only]
  - Switch output from sump sensor
- Smoke/CO Alarm Fault [no lockout info only]
  - Switch output from Smoke/CO sensor
- Dirty Filter Alarm [no lockout info only]
  - Output from dirty filter sensor

### Home Automation 2 - E24 HA2

With a closed dry contact signal, this input will cause an alarm and Alert Code 24 to indicate on the stat or flash on ABC. The AID Tool will allow configuration of this input between the following selections:

- No Action
- Home Automation Fault [no lockout info only]
  - Output from home automation system
- Security Alarm [no lockout info only]
  - Output from home security
- Sump Alarm Fault [no lockout info only]
  - Switch output from sump sensor
- Smoke/CO Alarm Fault [no lockout info only]
  - Switch output from Smoke/CO sensor
- Dirty Filter Alarm [no lockout info only]
  - Output from dirty filter sensor

### Aurora ‘Advanced’ Control LED Displays

These three LEDs display the status, configuration, and fault codes for the control. These can also be read in plain English via the Aurora AID Tool.

#### Status LED (LED3, Green)

Description of Operation	Fault LED, Green
Normal Mode	ON
Control is Non-functional	OFF
Test Mode	Slow Flash
Lockout Active	Fast Flash
Dehumidification Mode	Flash Code 2
Load Shed	Flash Code 5
Emergency Shutdown	Flash Code 6
On Peak Mode	Flash Code 7
(Future Use)	Flash Code 8
(Future Use)	Flash Code 9

#### Fault LED (LED1, Red)

Red Fault LED	LED Flash Code *	Lockout	Reset/Remove	Fault Condition Summary	
Normal - No Faults	Off	-			
ABC Basic Faults	Fault-Input	1	No	Auto	Tstat input error. Autoreset upon condition removal.
	Fault-High Pressure	2	Yes	Hard or Soft	HP switch has tripped (>600 psi)
	Fault-Low Pressure	3	Yes	Hard or Soft	Low Pressure Switch has tripped (<40 psi for 30 continuous sec.)
	Fault-Freeze Detection FP2	4	Yes	Hard or Soft	Freeze protection sensor has tripped (<15 or 30 degF for 30 continuous sec.)
	Fault-Freeze Detection FP1	5	Yes	Hard or Soft	Freeze protection sensor has tripped (<15 or 30 degF for 30 continuous sec.)
	Fault-Condensate Overflow	7	Yes	Hard or Soft	Condensate switch has shown continuity for 30 continuous sec.
	Fault-Over/Under Voltage	8	No	Auto	Instantaneous voltage is out of range. **Controls shut down until resolved.
	Fault-FP1 & 2 Snsr Error	11	Yes	Hard or Soft	If FP1 or 2 Sensor Error
ABC & AXB Advanced Faults	Fault-Compressor Monitor	10	Yes	Hard or Soft	Open Crkt, Run, Start or welded cont
	Non-CriticAXBSnsrErr	13	No	Auto	Any Other Sensor Error
	CriticAXBSnsrErr	14	Yes	Hard or Soft	Sensor Error for EEV or HW
	Alert-HotWtr	15	No	Auto	HW over limit or logic lockout. HW pump deactivated.
	Fault-VarSpdPump	16	No	Auto	Alert is read from PWM feedback.
	Not Used	17	No	Auto	IZ2 Com Fault. Autoreset upon condition removal.
	Non-CritComErr	18	No	Auto	Any non-critical com error
	Fault-CritComErr	19	No	Auto	Any critical com error. Auto reset upon condition removal
	Alarm - Low Loop Pressure	21	No	Auto	Loop pressure is below 3 psi for more than 3 minutes
	Alarm - Home Automation 1	23	No	Auto	Closed contact input is present on Dig 2 input - Text is configurable
Alarm - Home Automation 2	24	No	Auto	Closed contact input is present on Dig 3 input - Text is configurable	

**NOTES:**

\*All codes >11 use long flash for tens digit and short flash for the ones digit. 20, 30, 40, 50 etc. are skipped!

Alert' is a noncritical sensor or function that has failed. Normal operation of the heat pump is maintained but service is desired at some point.

## Reference Calculations

<p><b>Heating Calculations:</b></p> $\text{LWT} = \text{EWT} - \frac{\text{HE}}{\text{GPM} \times \text{C}^*}$ $\text{HE} = \text{C}^* \times \text{GPM} \times (\text{EWT} - \text{LWT})$	<p><b>Cooling Calculations:</b></p> $\text{LWT} = \text{EWT} + \frac{\text{HR}}{\text{GPM} \times \text{C}^*}$ $\text{HR} = \text{C}^* \times \text{GPM} \times (\text{LWT} - \text{EWT})$
--	--

**NOTE:** \* C = 500 for pure water, 485 for brine.

## Legend and Notes

### Abbreviations and Definitions

ELT = entering load fluid temperature to heat pump	kW = kilowatts
SWPD = source coax water pressure drop	EST = entering source fluid temperature to heat pump
LLT = leaving load fluid temperature from heat pump	HE = heat extracted in MBTUH
PSI = pressure drop in pounds per square inch	LST = leaving source fluid temperature from heat pump
LGPM = load flow in gallons per minute	HC = total heating capacity in MBTUH
FT HD = pressure drop in feet of head	COP = coefficient of performance, heating [HC/kW x 3.413]
LWPD = load coax water pressure drop	EER = energy efficiency ratio, cooling
LWT = leaving water temperature	TC = total cooling capacity in MBTUH
EWT = entering water temperature	HR = heat rejected in MBTUH
Brine = water with a freeze inhibiting solution	

### Notes to Performance Data Tables

The following notes apply to all performance data tables:

- Three flow rates are shown for each unit. The lowest flow rate shown is used for geothermal open loop/well water systems with a minimum of 50°F EST. The middle flow rate shown is the minimum geothermal closed loop flow rate. The highest flow rate shown is optimum for geothermal closed loop systems and the suggested flow rate for boiler/tower applications.
- Entering water temperatures below 40°F assumes 15% antifreeze solution.
- Interpolation between ELT, EST, and GPM data is permissible.
- Operation in the gray areas is not recommended.

# Water Pressure Drop

## Model 040

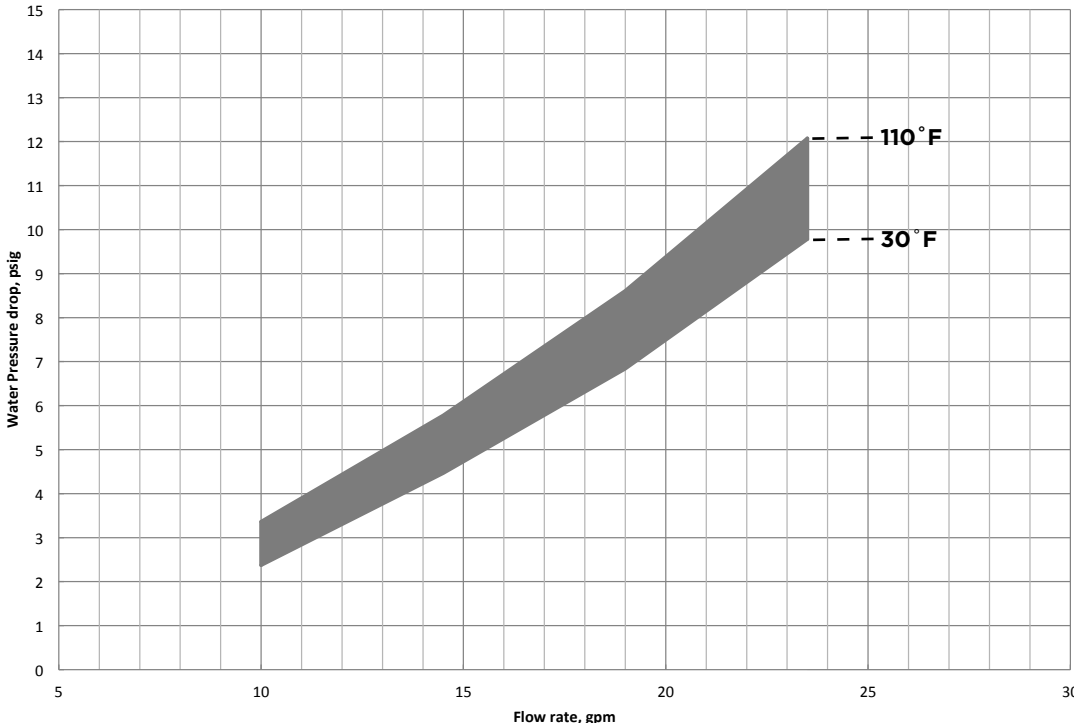

## Model 050

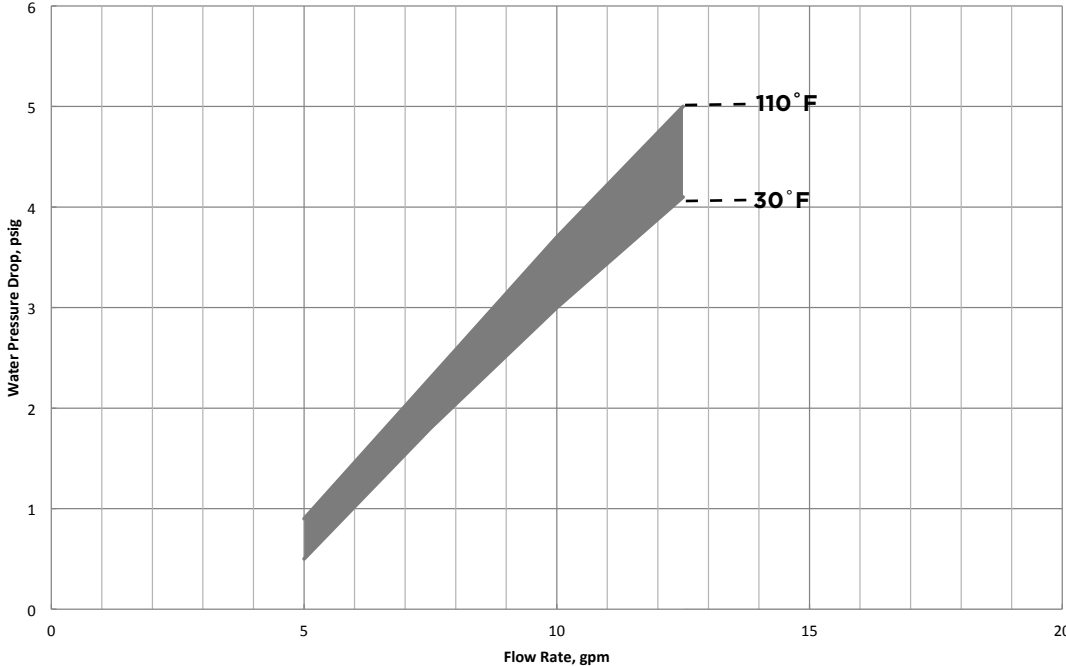

## Water Pressure Drop cont.

### Model 066

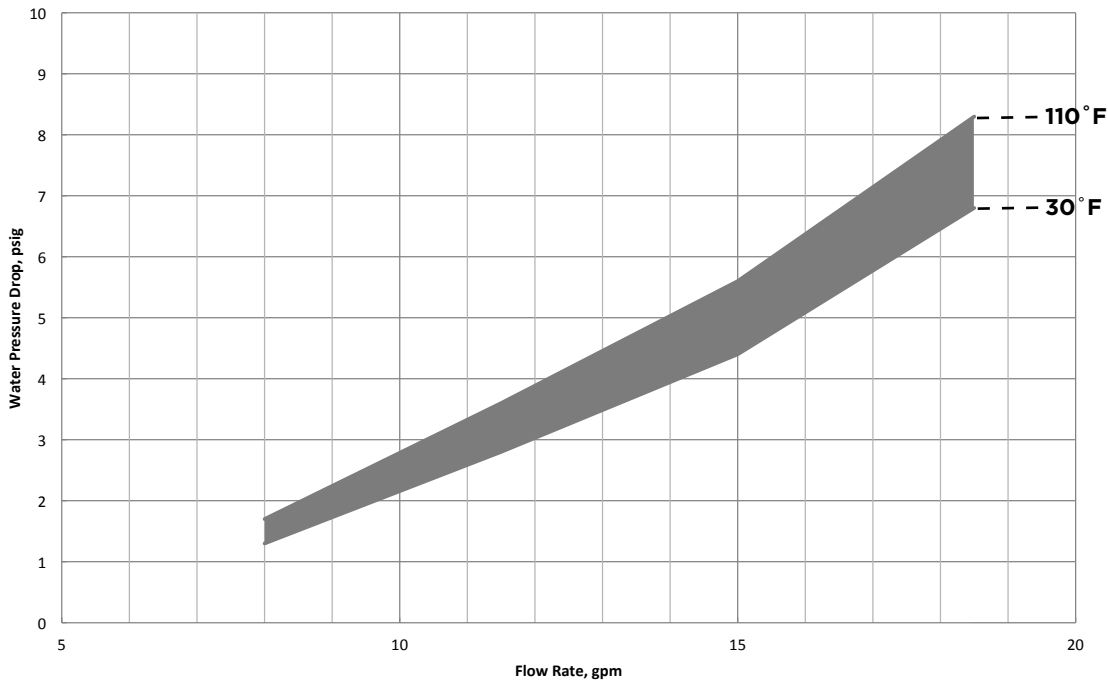

## Pressure Drop

Model	GPM	Pressure Drop (psi)						
		30°F	50°F	70°F	90°F	110°F	130°F	150°F
040	5.0	0.9	0.6	0.6	0.5	0.5	0.4	0.3
	7.5	2.3	2.1	2.0	1.9	1.8	1.6	1.5
	10.0	3.7	3.5	3.3	3.2	3.0	2.8	2.7
	12.5	5.0	4.7	4.4	4.2	4.1	3.9	3.7
050	8.0	1.7	1.4	1.4	1.3	1.3	1.2	1.1
	11.5	3.6	3.4	3.2	3.0	2.8	2.6	2.5
	15.0	5.6	5.4	5.0	4.6	4.4	4.3	4.1
	18.5	8.3	8.1	7.6	7.2	6.8	6.6	6.4
066	10.0	3.2	3.0	2.8	2.7	2.5	2.4	2.3
	14.5	5.5	5.3	5.1	4.9	4.7	4.6	4.5
	19.0	7.9	7.6	7.3	7.1	6.8	6.6	6.5
	23.5	11.5	11.3	11.0	10.8	10.3	10.1	9.9

7/8/14



## Operating Limits

Operating Limits	Cooling		Heating	
	°F	°C	°F	°C
<b>Source Side Water Limits</b>				
Minimum Entering Water	30	-1.1	20	-6.7
Normal Entering Water	85	29.4	60	15.6
Maximum Entering Water	110	43.3	90	32.2
<b>Load Side Water Limits</b>				
Minimum Entering Water	50	10.0	60	15.6
Normal Entering Water	60	15.6	100	37.8
Maximum Entering Water	90	32.2	140	60

**NOTES:** Minimum/maximum limits are only for start-up conditions, and are meant for bringing the space up to occupancy temperature. Units are not designed to operate at the minimum/maximum conditions on a regular basis. The operating limits are dependant upon three primary factors: 1) entering source temperature, 2) entering load temperature, and 3) flow rate (gpm). When any of the factors are at the minimum or maximum levels, the other two factors must be at the normal level for proper and reliable unit operation. Consult the Capacity Tables for each model to determine allowable normal operating conditions. Units are not designed for outdoor installation.

## Physical Data

Model	040	050	066
Compressor (1 each)	Scroll		
Factory Charge R410A, oz [kg]	94 [2.66]	108 [3.06]	142 [4.02]
Coax & Piping Water Volume - gal [l]	1.0 [3.94]	1.4 [5.25]	1.6 [6.13]
Weight - Operating, lb [kg]	305 [138.3]	340 [154.2]	360 [163.3]
Weight - Packaged, lb [kg]	320 [145.1]	355 [161.0]	375 [170.0]

7/8/14

## Flow Rates

### Source/Load Flow Rates

MODEL	MINIMUM OPEN LOOP FLOW RATE	MINIMUM CLOSED LOOP FLOW RATE	NORMAL SOURCE FLOW RATE	MAXIMUM FLOW RATE
040	5.0	8.0	10.0	12.0
050	8.0	12.0	15.0	17.0
066	10.0	14.0	19.0	21.0

7/8/14

## Thermistor and Compressor Resistance

### Thermistor Resistance

Thermistor Temperature (°F)	Microprocessor Resistance (Ohms)
5	75757-70117
14	57392-53234
23	43865-40771
32	33809-31487
41	26269-24513
50	20570-19230
59	16226-15196
68	12889-12093
77	10310-9688
86	8300-7812
95	6723-6337
104	5480-5172
113	4490-4246
122	3700-3504
131	3067-2907
140	2554-2424
149	2149-2019

7/8/14

### Compressor Resistance Chart

Model	208-230/60/1	
	Run	Start
040	0.46	0.85
050	0.36	0.97
066	0.36	0.97

Note: Table values have a +/- 7% tolerance

7/8/14

## Operating Parameters

### Heating Mode

Entering Load Temp (°F)	Entering Source Temp (°F)	Suction Pressure (psig)	Discharge Pressure (psig)	Superheat (°F)	Subcooling (°F)	Total Subcooling (°F)
60	30	67-82	208-235	7-14	6-14	20-30
	50	95-113	216-245	7-14	6-12	15-25
	70	124-144	225-255	8-19	5-15	6-16
	90	143-167	230-275	14-26	8-12	8-12
80	30	69-84	293-323	10-12	7-18	7-18
	50	98-125	302-335	12-14	8-16	25-35
	70	121-148	311-346	14-18	8-16	15-25
	90	150-179	319-363	14-26	8-16	8-16
100	30	77-85	378-411	10-12	7-15	45-55
	50	100-126	388-425	12-14	7-15	30-45
	70	133-152	398-438	14-18	3-12	25-35
	90	170-191	408-452	14-22	3-12	14-25
120	30	74-87	464-500	6-16	5-17	55-65
	50	106-128	474-515	5-17	5-15	40-50
	70	135-156	485-530	6-16	4-15	30-40
	90	180-195	500-545	8-14	3-9	20-30
130	30	74-87	520-560	6-16	5-17	55-65
	50	106-128	540-590	5-17	5-15	40-50
	70	140-160	550-600	6-16	3-9	30-40
	90	185-200	560-615	8-14	2-8	20-30
140	30	74-87	595-615	6-16	5-17	55-65
	50	106-128	600-625	5-17	5-15	40-50
	70	140-160	600-630	6-16	2-6	30-40
	90			Operation not recommended		

7/8/2014

## Operating Parameters cont.

### Cooling Mode

Entering Load Temp (°F)	Entering Source Temp (°F)	Suction Pressure (psig)	Discharge Pressure (psig)	Superheat (°F)	Subcooling (°F)
50	30	86-99	135-160	12-22	2-15
	50	92-107	191-214	10-19	4-15
	70	98-115	248-268	5-15	6-16
	90	101-119	335-367	6-15	8-16
	110	105-122	425-465	8-16	10-19
70	30	89-106	131-163	15-20	3-6
	50	103-125	194-223	11-15	6-9
	70	118-143	257-273	11-15	9-12
	90	125-151	344-381	8-12	12-14
	110	135-155	280-315	8-16	10-19
90	30	92-113	128-166	15-20	3-6
	50	115-143	197-233	11-15	6-9
	70	129-158	266-294	11-15	9-12
	90	145-165	350-390	20-30	8-19
	110	160-180	360-400	25-35	7-16
110	30	96-121	125-170	55-65	2-20
	50	127-161	200-243	41-52	4-18
	70	158-200	275-315	21-38	8-19
	90	155-175	360-400	30-40	5-15
	110	170-195	460-500	25-35	5-15

Notes: Operating parameters at 3 gpm/ton source and load flow.

7/8/2014

Consult the Capacity Tables for each 504W11 OptiHeat model for normal allowable operating conditions. Some of the conditions shown above are outside of the compressor operational limits for specific models.

## Antifreeze Correction

Catalog performance can be corrected for antifreeze use. Please use the following table and note the example given.

Antifreeze Type	Antifreeze % by wt	Heating		Cooling		Pressure Drop
		Load	Source	Load	Source	
EWT - °F [°C]		<b>80 [26.7]</b>	<b>30 [-1.1]</b>	<b>50 [10.0]</b>	<b>90 [32.2]</b>	<b>30 [-1.1]</b>
Water	0	1.000	1.000	1.000	1.000	1.000
Ethylene Glycol	10	0.990	0.973	0.976	0.991	1.075
	20	0.978	0.943	0.947	0.979	1.163
	30	0.964	0.917	0.921	0.965	1.225
	40	0.953	0.890	0.897	0.955	1.324
	50	0.942	0.865	0.872	0.943	1.419
Propylene Glycol	10	0.981	0.958	0.959	0.981	1.130
	20	0.967	0.913	0.921	0.969	1.270
	30	0.946	0.854	0.869	0.950	1.433
	40	0.932	0.813	0.834	0.937	1.614
	50	0.915	0.770	0.796	0.922	1.816
Ethanol	10	0.986	0.927	0.945	0.991	1.242
	20	0.967	0.887	0.906	0.972	1.343
	30	0.944	0.856	0.869	0.947	1.383
	40	0.926	0.815	0.830	0.930	1.523
	50	0.907	0.779	0.795	0.911	1.639
Methanol	10	0.985	0.957	0.962	0.986	1.127
	20	0.969	0.924	0.929	0.970	1.197
	30	0.950	0.895	0.897	0.951	1.235
	40	0.935	0.863	0.866	0.936	1.323
	50	0.919	0.833	0.836	0.920	1.399



**WARNING:** Gray area represents antifreeze concentrations greater than 35% by weight and should be avoided due to the extreme performance penalty they represent.

## Troubleshooting Guideline for Refrigerant Circuit

The chart below will assist in determining if measurements taken at the unit are within factory specifications and aid in accurate diagnosis (SYMPTOM) and repair. The chart is general in nature and represents whether a symptom would result in normal, high, or low readings from the typical operating range.

Symptom	Head Pressure	Suction Pressure	Compressor Amp Draw	Superheat	Subcooling	Water Temp. Differential
Under Charged System (Possible Leak)	Low	Low	Low	High	Low	Low
Over Charged System	High	High	High	Normal	High	Normal
Low Water Flow Evaporator	Low/Normal	Low/Normal	Low	Low	High	High
Low Water Flow Condensor	High	High	High	High	Low	High
High Water Flow Evaporator	Normal	Low	Normal	High	Normal	Low
High Water Flow Condensor	Low	Low	Low	Low	High	Low
Restricted TXV (Check Service Advisory)	High	Low	Normal/Low	High	High	Low
Insufficient Compressor (Possible Bad Valves)	Low	High	Low	High	Normal/High	Low
TXV - Bulb Loss of Charge	Low	Low	Low	High	High	Low
Scaled Coaxial Heat Exchanger Evaporator	Low	Low	Low	Normal/Low	High	Low
Scaled Coaxial Heat Exchanger Condensor	High	High	High	Normal/Low	Low	Low
Restricted Filter Drier	Check temperature difference (delta T) across filter drier.					

## Cooling Cycle Analysis

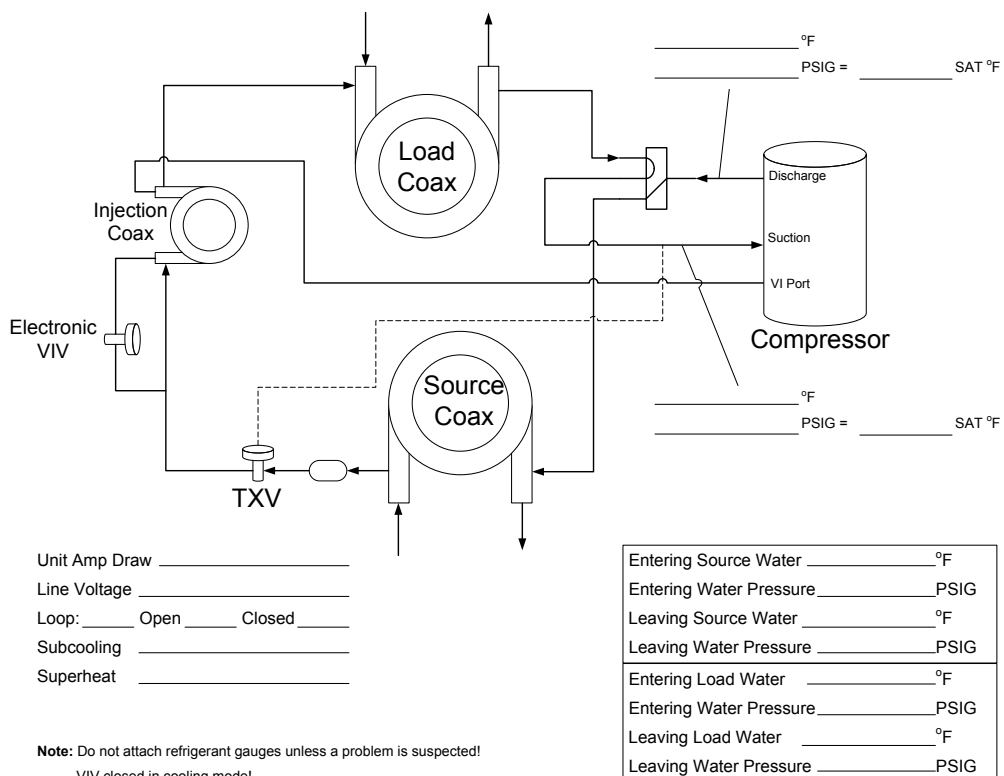

## Heating Cycle Analysis

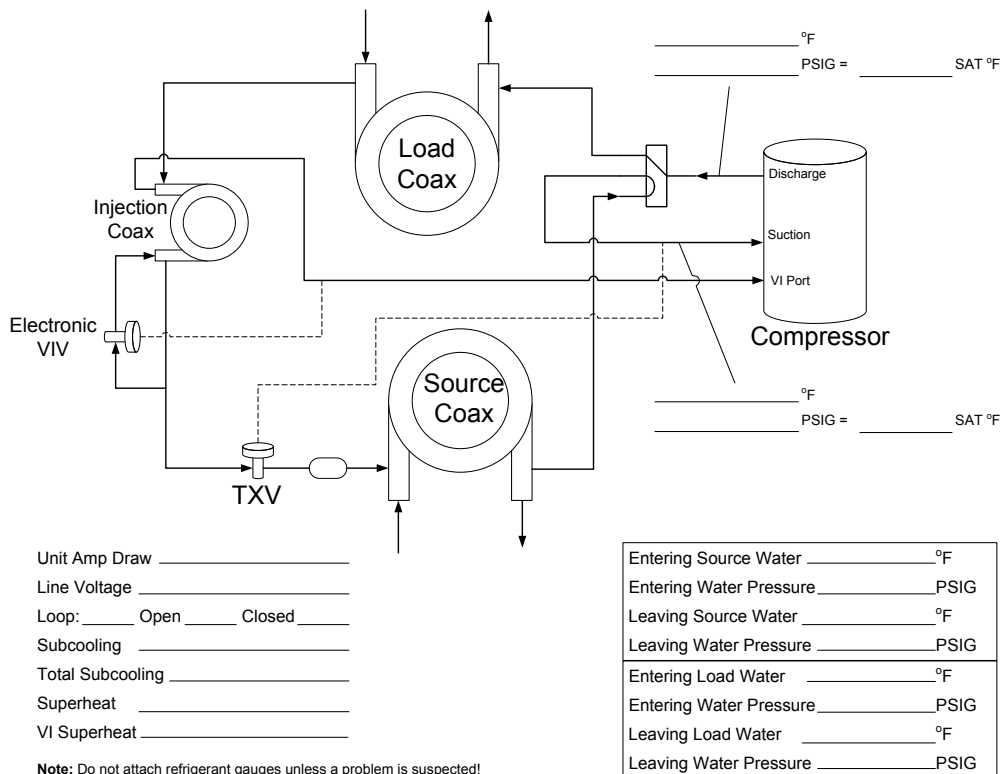

## 5 Series 504W11 OptiHeat Startup and Troubleshooting Form

Company Name: \_\_\_\_\_ Company Phone No: \_\_\_\_\_  
 Technician Name: \_\_\_\_\_ Date: \_\_\_\_\_  
 Model No: \_\_\_\_\_ Serial No: \_\_\_\_\_  
 Owner's Name: \_\_\_\_\_ Open or Closed Loop: \_\_\_\_\_  
 Installation Address: \_\_\_\_\_ Installation Date: \_\_\_\_\_

Check One

Start up/Check-out for new installation       Troubleshooting      Problem: \_\_\_\_\_

1. FLOW RATE IN GPM (SOURCE/LOAD SIDE HEAT EXCHANGER)

Water In Pressure:	a. _____ PSI	a. _____ PSI
Water Out Pressure:	b. _____ PSI	b. _____ PSI
Pressure Drop = a - b	c. _____ PSI	c. _____ PSI
Convert Pressure Drop to Flow Rate (refer to <i>Pressure Drop</i> table)	d. _____ GPM	d. _____ GPM

2. TEMPERATURE RISE OR DROP ACROSS SOURCE SIDE HEAT EXCHANGER

	COOLING	HEATING
Water In Temperature:	e. _____ °F	e. _____ °F
Water Out Temperature:	f. _____ °F	f. _____ °F
Temperature Difference:	g. _____ °F	g. _____ °F

3. TEMPERATURE RISE OR DROP ACROSS LOAD SIDE HEAT EXCHANGER

	COOLING	HEATING
Water In Temperature:	h. _____ °F	h. _____ °F
Water Out Temperature:	i. _____ °F	i. _____ °F
Temperature Difference:	j. _____ °F	j. _____ °F

4. HEAT OF REJECTION (HR) / HEAT OF EXTRACTION (HE) CALCULATION

HR or HE = Flow Rate x Temperature Difference x Brine Factor\*  
 d. (above) x g. (above) x 485 for Methanol or Environol, 500 for water\*  
 Heat of Extraction (Heating Mode) = \_\_\_\_\_ btu/hr  
 Heat of Rejection (Cooling Mode) = \_\_\_\_\_ btu/hr  
 Compare results to Capacity Data Tables

Note: Steps 5 through 8 need only be completed if a problem is suspected

5. WATTS

	COOLING	HEATING	HYDRONIC
Volts:	m. _____ VOLTS	m. _____ VOLTS	m. _____ VOLTS
Total Amps (Comp. + Fan):	n. _____ AMPS	n. _____ AMPS	n. _____ AMPS
Watts = m. x n. x 0.85	o. _____ WATTS	o. _____ WATTS	o. _____ WATTS

6. CAPACITY

Cooling Capacity = HR. - (o. x 3.413)      p. \_\_\_\_\_ btu/hr  
 Heating Capacity = HE. + (o. x 3.413)      p. \_\_\_\_\_ btu/hr

7. EFFICIENCY

Cooling EER = p. / o.      q. \_\_\_\_\_ EER  
 Heating COP = p. / (o. x 3.413)      q. \_\_\_\_\_ COP

8. SUPERHEAT (S.H.) / SUBCOOLING (S.C.)

	COOLING	HEATING	HYDRONIC
Suction Pressure:	r. _____ PSI	r. _____ PSI	r. _____ PSI
Suction Saturation Temperature:	s. _____ °F	s. _____ °F	s. _____ °F
Suction Line Temperature:	t. _____ °F	t. _____ °F	t. _____ °F
Superheat = t. - s.	u. _____ °F	u. _____ °F	u. _____ °F
Head Pressure:	v. _____ PSI	v. _____ PSI	v. _____ PSI
High Pressure Saturation Temp.:	w. _____ °F	w. _____ °F	w. _____ °F
Liquid Line Temperature*:	x. _____ °F	x. _____ °F	x. _____ °F
Subcooling = w. - x.	y. _____ °F	y. _____ °F	y. _____ °F

\* Note: Liquid line is between the source heat exchanger and the expansion valve in the cooling mode; between the load heat exchanger and the expansion valve in the heating mode.

## Troubleshooting

Should a major problem develop, refer to the following information for possible causes and corrective steps:

### Compressor Won't Run

1. The fuse may be blown or the circuit breaker is open. Check electrical circuits and motor windings for shorts or grounds. Investigate for possible overloading. Replace fuse or reset circuit breakers after the fault is corrected.
2. Supply voltage may be too low. Check voltage with a volt meter.
3. Remote control system may be faulty. Check aquastat for correct wiring, setting and calibration. Check 24-volt transformer for burnout.
4. Wires may be loose or broken. Replace or tighten.
5. The low pressure switch may have tripped due to one or more of the following:
  - a. Fouled or plugged coaxial heat exchangers
  - b. Low or no water flow (source side heating, load side cooling)
  - c. Water too cold (source side heating)
  - d. Low refrigerant
6. The high pressure switch may have tripped due to one or more of the following:
  - a. Fouled or plugged coaxial heat exchanger
  - b. Low or no water flow (source side cooling, load side heating)
  - c. Water too warm (source side cooling)
7. Check the capacitor.
8. The compressor overload protection may be open. If the compressor dome is extremely hot, the overload will not reset until cooled down. If the overload does not reset when cool, it may be defective. If so, replace the compressor.
9. The internal winding of the compressor motor may be grounded to the compressor shell. If so, replace the compressor.
10. The compressor winding may be open. Check continuity with an ohm meter. If the winding is open, replace the compressor.

### Insufficient Cooling or Heating

1. Check aquastat for improper location.
2. Check for restriction in water flow.
3. Check subcooling for low refrigerant charge.
4. The reversing valve may be defective and creating a bypass of refrigerant. If the unit will not cool, check the reversing valve coil.
5. Check thermal expansion valve for possible restriction of refrigerant flow.

### Noisy Unit Operation

1. Check compressor for loosened mounting bolts. Make sure compressor is floating free on its isolator mounts.
2. Check for tubing contact with the compressor or other surfaces. Readjust it by bending slightly.
3. Check screws on all panels.
4. Check for chattering or humming in the contactor or relays due to low voltage or a defective holding coil. Replace the component.
5. Check for proper installation of vibration absorbing material under the unit. Unit must be fully supported, not just on corners.
6. Check for abnormally high discharge pressures.
7. Check that compressor shipping bolt has been removed.

## Preventive Maintenance

1. Keep all air out of the water lines. An open loop system should be checked to ensure that the well head is not allowing air to infiltrate the water line. Lines should always be airtight.
2. Keep the system under pressure at all times. In open loop systems, it is recommended that a water control valve be placed in the discharge line to prevent loss of pressure during off cycles. Closed loop systems must have a positive static pressure.

**NOTES:** If the installation is performed in an area with a known high mineral content in the water, it is best to establish a periodic maintenance schedule to check the water-to-refrigerant heat exchanger on a regular basis. Should periodic cleaning be necessary, use standard cleaning procedures which are compatible with either the cupronickel or copper water lines. Generally, the more water flowing through the unit, the less chance there is for scaling. Low GPM flow rates produce higher temperatures through the coil. To avoid excessive pressure drop and the possibility of copper erosion, do not exceed GPM flow rate as shown on the specification sheets for each unit.

### Cleaning Procedure

1. Close the inlet and outlet water valves to isolate the heat pump from the well system, water heater or loop pumps.
2. Disconnect piping and remove solenoid valve, pumps, etc. from the inlet and outlet connections on the heat pump.
3. Connect plastic hoses from the circulating pump\* to the outlet of the water-to-refrigerant heat exchanger to be de-limed (refer to the Cleaning Connections illustration).
4. Connect a plastic hose from the circulating pump inlet to the bottom of a plastic five (5) gallon pail (refer to the Cleaning Connections illustration).
5. Connect a plastic hose from the inlet line of the water-to-refrigerant heat exchanger to the plastic pail. Secure tightly to ensure that circulating solution does not spill (refer to the Cleaning Connections illustration).
6. Partially fill the plastic pail with clear water (about two-thirds full) and prime the circulating pump. Circulate until lines are full.
7. Start the circulating pump and slowly add a commercial scale remover\*\* to the water as recommended by the scale remover manufacturer's directions.
8. Be sure the pump circulation is opposite to the normal water flow through the water-to-refrigerant heat exchanger.
9. Maintain re-circulation until all scale and other material has been dissolved and flushed from the heat exchanger.
10. Upon completion of the procedure. Safely dispose of the solution.
11. Rinse the pump and plastic pail. Refill with clear water.
12. Start the pump circulation and flush the system until all acid residue has been removed from the system. Refill the plastic pail until only clear water is circulated.
13. Turn off the circulating pump and disconnect all hoses and fittings.
14. Replace solenoid valves, pumps, hoses and other devices in their original locations. On closed loop systems, be sure to purge between the flow center and unit to avoid getting air into the loop.
15. Put the heat pump back into operation. Check for proper operating temperature.

### Cleaning Connections

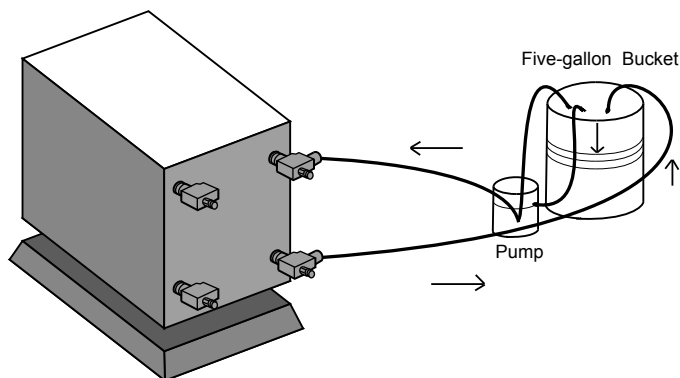

**WARNING:** This process involves a caustic solution and may be harmful to people and animals. Wear protective equipment (glasses, rubber gloves, apron, etc.)

**NOTES:** \*Virginia Chemical Co. makes a Pump model H460.

\* W.W. Granger Co. sells a Pump #2P-017 made by Little Giant.

\*\*Virginia Chemical Co. makes a liquid ice machine cleaner which should be used on water-to-refrigerant heat exchangers serving a domestic hot water system. Calci-Solve by NYCO is available for use on other heat exchangers



## Service Parts - Residential

Part Description		040	050	066
		208-230/60/1		
Refrigeration Components	Compressor 208-230/60/1	34P663-01	34P664-01	34P665-01
	Compressor Capacitor 208-230/60/1	16P002D25	16P002D41	
	Compressor Sound Jacket	92P526-01		
	Thermal Expansion Valve	33P605-10	33P605-15	33P605-07
	VI Expansion Valve	33P617-01		
	VI Expansion Valve Solenoid	33P617-02		
	Filter Drier for 'Reversible Models'	36P500B01	36P500B02	
	Filter Drier for 'Heating Only' Models	36P510-01		
	Reversing Valve with Coil	33P503-05	33P526-05	
	Source Coaxial Heat Exchanger (copper)	62P597-01	62P598-01	62P599-01
	Load Coaxial Heat Exchanger (copper)	62P597-01	62P598-01	62P599-01
	VI Coaxial Heat Exchanger	62P617-01		62P596-01
Safety / Sensor	High Pressure Switch	35P513-01		
	Low Pressure Switch	35P506B01		
	Freeze Detection Sensor	12P505-08		
Electrical	Compressor Contactor - 208-230/60/1	13P004A03		
	Transformer - 208-230v	15P501-02		
	Load Pump Relay	13P711-01		
	Pump Power Block	12P500A01		
	Pump Circuit Breaker	19P583-01		
	VI Pressure Transducer	35P554-01		
	VI Temperature Sensor	12P555-09		
	IntelliStart Soft Starter	IS1B16-32SN	not available	
Grounding Lug	12P004A			
Cabinet	Rear Access Panel	40P749-01	40P749-01	40P749-01
	Front Access Panel	40P749-01	40P749-01	40P749-01
	Top Panel	42C548-01	42C548-01	42C548-01

7/8/14

## Notes

---

## Revision Guide

---

<b>Pages:</b>	<b>Description:</b>	<b>Date:</b>	<b>By:</b>
All	Literature Creation	5 Feb 2015	MA





Manufactured by  
WaterFurnace International, Inc.  
9000 Conservation Way  
Fort Wayne, IN 46809  
[www.waterfurnace.com](http://www.waterfurnace.com)

Product: **5 Series 504W11 OptiHeat**  
Type: Geothermal Hydronic Heat Pump  
Size: 3-5 Tons  
Document: Installation Manual

IM2508WN 05/15