

N72.30905

NASA TECHNICAL NOTE



NASA TN D-6974

NASA TN D-6974

**CASE FILE
COPY**

**APOLLO EXPERIENCE REPORT —
LUNAR MODULE COMMUNICATIONS SYSTEM**

*by Reinhold H. Dietz, Donald E. Rhoades,
and Louis J. Davidson*

*Manned Spacecraft Center
Houston, Texas 77058*

NATIONAL AERONAUTICS AND SPACE ADMINISTRATION • WASHINGTON, D. C. • SEPTEMBER 1972

1. Report No. NASA TN D-6974		2. Government Accession No.		3. Recipient's Catalog No.	
4. Title and Subtitle APOLLO EXPERIENCE REPORT LUNAR MODULE COMMUNICATIONS SYSTEM				5. Report Date September 1972	
				6. Performing Organization Code	
7. Author(s) Reinhold H. Dietz, Donald E. Rhoades, and Louis J. Davidson, MSC				8. Performing Organization Report No. MSC S-324	
9. Performing Organization Name and Address Manned Spacecraft Center Houston, Texas 77058				10. Work Unit No. 914-13-00-00-72	
				11. Contract or Grant No.	
12. Sponsoring Agency Name and Address National Aeronautics and Space Administration Washington, D. C. 20546				13. Type of Report and Period Covered Technical Note	
				14. Sponsoring Agency Code	
15. Supplementary Notes The MSC Director waived the use of the International System of Units (SI) for this Apollo Experience Report, because, in his judgment, the use of SI Units would impair the usefulness of the report or result in excessive cost.					
16. Abstract The development of the lunar module communications system is traced from the initial concept to the operational system used on manned lunar missions. Included are the problems encountered during the development, the corrective actions taken, and recommendations for similar equipment in future programs. The system was designed to provide communications between the lunar module and the Manned Space Flight Network, between the lunar module and the command and service module, and between the lunar module and the extravehicular crewmen. The system provided the equipment necessary for voice, telemetry, and television communications; ranging information; and various communications links.					
17. Key Words (Suggested by Author(s)) * Communications * PCM Telemetry * Apollo * PRN Ranging * S-Band * Up-Data-Link Commands * VHF * Spacecraft Antennas				18. Distribution Statement	
19. Security Classif. (of this report) None		20. Security Classif. (of this page). None		21. No. of Pages 69	22. Price \$3.00

CONTENTS

Section	Page
SUMMARY	1
INTRODUCTION	1
Concept	2
Communications Functions	4
PROGRAM PLAN AND MANAGEMENT	6
Program Plan	7
Program Management	8
SYSTEM DESIGN AND ANALYSIS	11
System Requirements	12
System Analysis	14
System Design	14
System Operations	18
Developmental-Flight-Instrumentation Communications	24
Portable Life-Support System Communications	25
DEVELOPMENT	27
System Development	27
Electronic Replaceable Assembly Development	33
TEST PROGRAM	36
Test Philosophy and System Tests	37
Ground-Vehicle Tests	39
Flight-Vehicle Tests	41
SYSTEM RELIABILITY AND PERFORMANCE	44
SIGNIFICANT MODIFICATIONS AND PROBLEMS	45

Section	Page
Steerable Antenna	45
S-Band Power Amplifier	48
S-Band Transceiver	49
The VHF Transceiver	50
Digital Up-Link Assembly	51
Erectable Antenna	51
Signal-Processor Assembly	52
FLIGHTS	53
Apollo 5/LM-1	53
Apollo 9/LM-3	53
Apollo 10/LM-4	54
Apollo 11/LM-5	55
RECOMMENDATIONS FOR FUTURE MANNED-SPACECRAFT PROGRAMS	56
Management Recommendations	56
Procurement Recommendations	57
Testing Recommendations	57
Operations Recommendations	58
Design Recommendations	58
CONCLUDING REMARKS	59
REFERENCE	60

TABLES

Table		Page
I	FUNCTIONAL AND PERFORMANCE REQUIREMENTS	11
II	REAL-TIME TELEMETRY MEASUREMENTS	22
III	COMMUNICATIONS LINKS	23
IV	FAILURE SUMMARY FOR MAJOR SECTIONS OF THE LM COMMUNICATIONS SYSTEM	45

FIGURES

Figure		Page
1	Lunar module inflight communications links	4
2	Lunar-surface communications	5
3	Program order of key milestones and events	7
4	Lunar module communications and management structure	9
5	Aft-equipment-bay cold rails and ERA arrangement	12
6	Lunar module communications-system antenna locations	18
7	Simplified block diagram of LM communications system	19
8	Apollo S-band modes	20
9	Extravehicular-communications-system modes of operation	
	(a) Dual mode	21
	(b) Primary backup mode	21
	(c) Secondary backup mode	21
10	Developmental-flight-instrumentation communications between LM and MSFN	24
11	Lunar module communications DFI equipment	25
12	Block diagram of LM communications system (subcontractor proposal of October 1963)	29

Figure		Page
13	Block diagram of LM communications system after CCA-61	31
14	System packaging after CCA-61	32
15	Lunar module communications system	33
16	Communications-system qualification history	38

ACRONYMS

AGC	automatic gain control
AM	amplitude modulation
ASPO	Apollo Spacecraft Program Office
CCA	contract-change authorization
CCB	Configuration Control Board
CSM	command and service module
CTS	communications test station
DCA	digital-command assembly
DFC	dual-feed coupler
DFI	developmental flight instrumentation
DFT	design-feasibility test
DL&E	design limit and endurance
DSKY	display and keyboard
DUA	digital up-link assembly
DVT	design-verification test
EMI	electromagnetic interference
EMU	extravehicular mobility unit
ERA	electronic replaceable assembly
EV	extravehicular
EVA	EV activity
EVCS	EV communications system
FM	frequency modulation
g. e. t.	ground elapsed time
GORP	ground-operations requirements plan

GSE	ground-support equipment
JPL	Jet Propulsion Laboratory
KSC	John F. Kennedy Space Center
LGC	LM guidance computer
LM	lunar module
LRP	LM replaceable package
LTA	LM test article
MSC	Manned Spacecraft Center
MSFN	Manned Space Flight Network
OCP	operational checkout procedure
PCM	pulse code modulation
PCMTEA	PCM and timing-electronics assembly
PCS	parts, components, subassemblies
PLSS	portable life-support system
PM	phase modulation
PMO	Program Management Office
PMP	premodulation processor
PP	preproduction
PRN	pseudorandom noise
PTT	push to talk
RAT	reliability-assurance test
RF	radio frequency
SN	serial number
SPA	signal-processor assembly
SSC	space-suit communicator
TCRD	test and checkout requirements document

T/R	transmit/receive
TV	television
UHF	ultrahigh frequency
VHF	very high frequency
VOX	voice-operated keying

APOLLO EXPERIENCE REPORT
LUNAR MODULE COMMUNICATIONS SYSTEM

By Reinhold H. Dietz, Donald E. Rhoades,
and Louis J. Davidson
Manned Spacecraft Center

SUMMARY

The lunar module communications system was designed to be compatible with existing lunar module systems and to maintain the high standard of reliability and versatility imposed upon the command and service module communications system. The lunar module communications system was to provide essential communications between the lunar module and the Manned Space Flight Network on earth, between the lunar module and the command and service module when the latter was in lunar orbit, and between the lunar module and the extravehicular crewmen on the lunar surface. Space and weight restrictions were more critical for the lunar module than for the command and service module; therefore, the command and service module equipment could not be used in the lunar module on a direct-interchange basis, and new designs were required. The system was to provide voice and telemetry from the lunar module crewmen and systems and was to act as the communications relay between crewmen on the lunar surface and the other communications units within the space-flight network. The system was to supply ranging information essential to the rendezvous of the lunar module with the command and service module after lift-off from the lunar surface. This system was developed successfully within the period imposed by program objectives. The developmental phases closely approximated those of the command and service module equipment. Qualification tests were designed to ensure satisfactory operation under all environmental conditions encountered on Apollo missions of any duration. Developmental problems generally were associated with the environmental and mission-life requirements. Modifications to circuit design, packaging, and manufacturing techniques were incorporated to correct these problems. The experience gained from the development of this system produced many recommendations for future programs in the areas of management, procurement, testing, operations, and design.

INTRODUCTION

The lunar module (LM) communications system was designed to provide communications between the LM and the Manned Space Flight Network (MSFN), between the LM and the command and service module (CSM), and between the LM and the extravehicular (EV) crewmen on the lunar surface. In this document, the development of the LM communications system is reviewed from the initial concepts to the operational

system used on the Apollo 11 mission. The experiences outlined in this document have resulted in information and insights useful for future design and development of near-space and deep-space communications systems. In this regard, particular note should be made of the section entitled "Recommendations for Future Manned-Spacecraft Programs."

Concept

The LM communications system was designed to provide the following types of communications between the spacecraft, the EV crewmen, and the MSFN.

1. Precision deep-space tracking and ranging
2. High-bit-rate telemetry
3. Voice
4. Biomedical (electrocardiogram) data
5. Extravehicular mobility unit (EMU) data
6. Television (TV)
7. Keyed continuous wave (emergency key)

As mission planning evolved, concepts for the LM communications system changed. Additional communications requirements developed, such as the following.

1. High-capacity up-data-link system
2. Telemetry between the LM and the CSM
3. Up-link-voice backup
4. Voice-relay and conference capability
5. Additional channels for biomedical and EMU data
6. Ranging data between spacecraft using the communications systems

The LM communications system functioned at short ranges (e. g. , LM to CSM) and at lunar ranges (e. g. , LM to MSFN). The frequencies for these two ranges were determined early in the program. The VHF band was selected for short-range communications, and the S-band was selected for lunar-distance communications. The VHF frequencies presented few developmental difficulties; data-channel requirements were low, and prior experience could be used.

Experience accumulated by the Jet Propulsion Laboratory (JPL) in its unmanned lunar and planetary programs led to serious consideration of S-band frequencies for

lunar-distance communications. The S-band selection for lunar-distance communications was a compromise among equipment availability, frequency allocations, circuit losses, and antenna gains at the allocated frequencies. A window with high propagation of the carrier wave and low galactic-noise levels was selected in the S-band.

The unified S-band system that was selected was similar to the system being developed for the CSM and allowed transmission of all data on one carrier. Two sub-carriers were used on both the up-link frequency and the down-link frequency to multiplex voice and data. The use of one carrier for all communications functions minimized the system weight, volume, heat-dissipation, and power-consumption requirements.

The deep-space tracking and ranging function of the LM communications system required data of sufficient accuracy and resolution for the descent and ascent operations of the LM. Again, the unified S-band system was selected for this function. The initial range measurement was calculated by accurately measuring the transmission time of a pseudorandom-noise (PRN) code and subtracting the time delays of the communications system. The PRN code could be turned off, and continued range computation could be obtained by Doppler-count integration.

During the early phases of the program, the method of providing voice, data, and ranging functions between the LM and the CSM and between the LM and the EV crewmen went through several iterations (including one receiver and one transmitter, two receivers and three transmitters, and two receivers and two transmitters) as a result of changing mission requirements. The VHF-communications method that was selected consisted of two VHF/amplitude-modulation (AM) receivers and two VHF/AM transmitters, each using two frequencies. Voice, data, and ranging information were modulated on the VHF carrier by keying the carrier on and off at the respective data rates.

In the final concept, the LM communications system included an S-band receiver, an S-band power amplifier, a two-channel VHF transceiver, a signal-processor assembly (SPA), a portable TV camera, a digital up-link assembly (DUA), a pulse-code-modulation and timing-electronics assembly (PCMTEA), an antenna system, and the necessary switches and RF cables. The communications system had the following characteristics.

1. While the crewmen were in the LM, a hardwire umbilical cord routed the received voice signal to the headset and the voice and biomedical data to the communications system for transmission.
2. Transducers, which were located at various places on the LM and within the various systems, provided LM systems data to the LM communications system. The transducer outputs were converted to a data format that was suitable for transmission to the MSFN.
3. During lunar-stay operations, a TV camera could be connected directly to the communications system and could provide transmissions in either black and white or color. Also, voice and EMU-data transmissions from EV crewmen were processed and routed by the communications system.

4. The S-band link was used for voice and data transmissions from the MSFN to the LM and for voice, biomedical, EMU, pulse-code-modulation (PCM) telemetry, emergency-key, and TV transmissions from the LM to the MSFN. In addition, the S-band transceiver acted as a transponder for the PRN ranging code. The retransmitted PRN ranging code, which was coherent with the received code, allowed the MSFN to determine the LM range accurately. The coherent-phase relation between the carrier transmitted and received from the spacecraft allowed measurement of the range rate at the MSFN by means of a two-way Doppler measurement.

5. The VHF link was operated in either a simplex mode or a duplex mode. Normal LM/CSM inflight voice communications were performed using simplex operations, whereas the LM/extravehicular-activity (EVA) voice and EMU-data communications were performed using duplex operation. In addition, low-bit-rate PCM-data transmission by VHF was available from the LM to the CSM during those portions of the mission when the line of sight between the LM and the MSFN was lost.

6. Conference capabilities were provided among the LM, the CSM, and the MSFN and among the LM, the EV crewmen, and the MSFN using both S-band and VHF equipment.

Communications Functions

Operation of the LM communications system during the inflight and lunar-stay phases of a mission is described in the following paragraphs and is shown in figures 1 and 2.

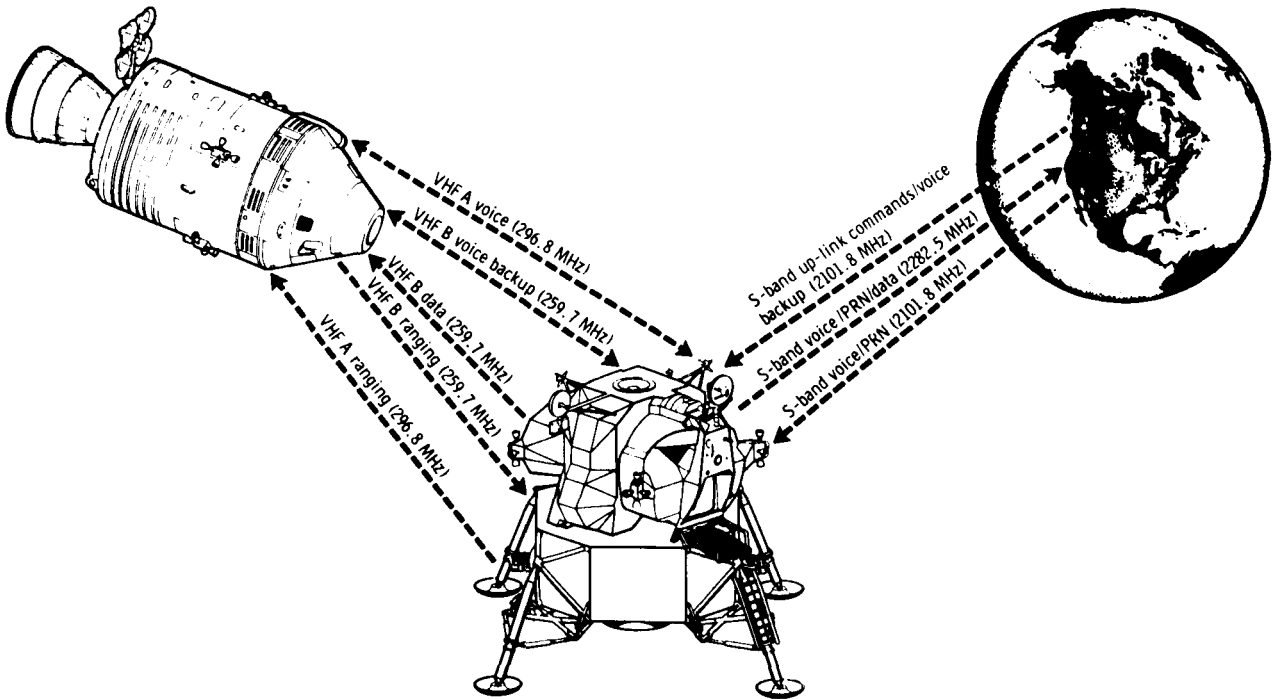

Figure 1. - Lunar module inflight communications links.

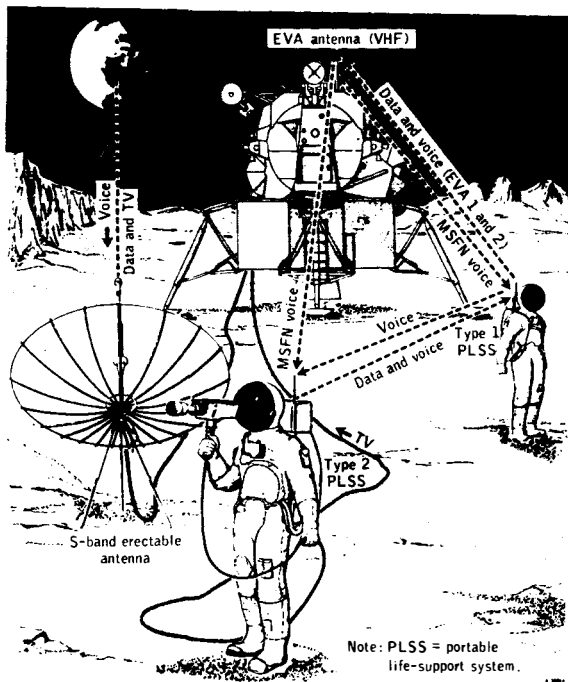

Figure 2. - Lunar-surface communications.

Inflight communications on the earth side of the moon. - The S-band equipment was used for inflight communications between the LM and the MSFN when the LM was in line of sight with the MSFN. The communications system transmitted voice, biomedical data, PCM telemetry data, and the retransmitted PRN ranging code. The communications system received voice, data, and the PRN ranging code from the MSFN.

The VHF voice communications between the LM and the CSM were accomplished by simplex operation of one channel (designated VHF A) of the two-channel VHF transceiver. The second channel (VHF B) was available as a backup. The VHF ranging was accomplished by receiving the ranging code on the VHF B receiver and retransmitting the ranging code from the VHF A transmitter. This mode was used in operations on both the earth side and the far side of the moon.

A three-way voice conference among the CSM, the LM, and the MSFN could be provided by real-time relay switching, which was available on the LM, on the CSM, and at the MSFN.

Inflight communications on the far side of the moon. - During the phase of the mission when the LM and the CSM were not in line of sight with the MSFN, S-band communications with the MSFN were not possible. However, communications between the CSM and the LM were possible.

In addition to the two-way VHF voice link, a one-way data link existed from the LM to the CSM. The LM VHF B transmitter was used to transmit low-bit-rate data. A data-storage unit (basically, a tape recorder with record and playback capabilities) on board the CSM was used to record the data. The tape-recorder speed during this phase of the mission allowed 2 hours of recording time. When the CSM was in line of sight with the MSFN, the tape-recorder speed was increased by a factor of 32, and the recorded LM data were transmitted to the MSFN in 2 to 3 minutes.

Lunar-surface communications. - Before egressing from the LM, the commander or LM pilot deployed the VHF antenna used for communications between the LM and the EV crewmen. After leaving the LM, the EV crewmen erected and positioned the S-band erectable antenna, which was stored in a cylindrical container located in quad area number 1 of the descent stage.

The VHF link was used for voice and data transfer between the LM and the EV crewmen. Operation was duplex: voice transmissions from the LM to the EV crewmen were on VHF A, and voice and EMU-data transmissions from the EV crewmen to the LM were on VHF B. If a malfunction occurred in the VHF equipment, duplex operation would continue with voice transmission from the LM to the EV crewmen on VHF B and with voice transmission from the EV crewmen to the LM on VHF A. Because EMU-data transmission on VHF A does not exist, the EMU data would be lost during this backup mode.

The S-band link was used for voice, data, and TV transmissions between the LM and the MSFN. The signals were combined and transmitted by frequency modulation (FM) of the 2282.5-megahertz carrier.

During EVA, communications with the CSM were by MSFN relay. The time required for a radio transmission between the earth and the moon is approximately 1.2 to 1.5 seconds. Of course, the relay operation could occur only when the MSFN and the CSM were in line of sight.

PROGRAM PLAN AND MANAGEMENT

Reliability, weight, schedule, and cost were the primary considerations involved in the formulation and management of the program. To ensure successful completion of the program, activities were planned and coordinated to provide the maximum flow of data from the design and analysis phase through the hardware development and qualification phase to final delivery. Major milestones during design and analysis were the conceptual-design freeze and the development and testing of prototype hardware. After the conceptual-design freeze, prototype models were manufactured and subjected to environmental design-limit and endurance qualification tests. Simultaneously, integrated tests were planned for the major components of the system. After completion of the prototype qualification tests and before the integrated tests, the qualified flight equipment was scheduled for delivery to the contractor. The original program plan is outlined in figure 3. Details of the test philosophy and plan are in the section entitled "Test Program."

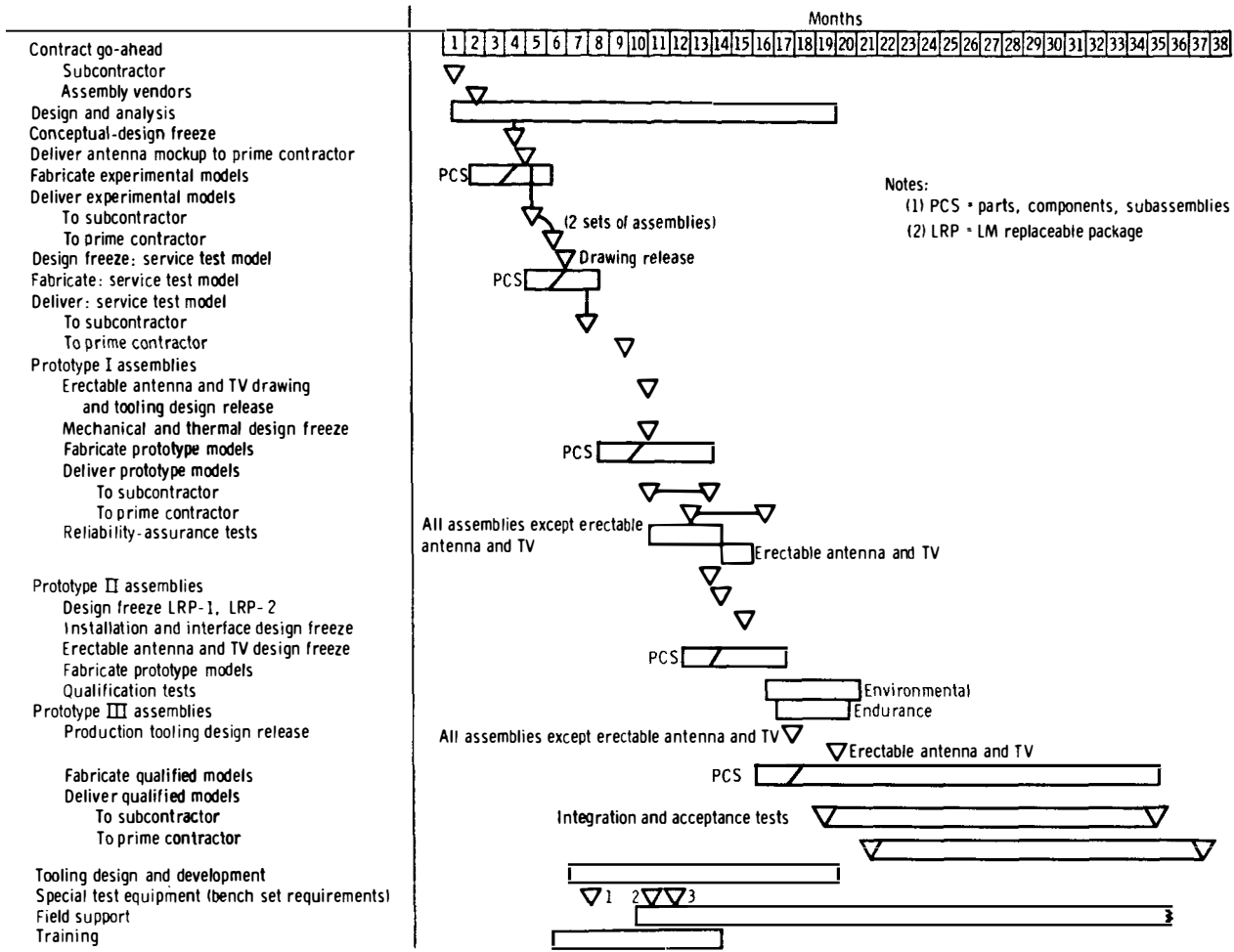

Figure 3. - Program order of key milestones and events.

Program Plan

The original program plan was modified because more data were gathered than were anticipated during design-feasibility tests (DFT's) and integration tests. These data, combined with schedule and cost trade-offs, resulted in the elimination of some test models and test programs at the vendor level. Other tests were added — such as the LM compatibility tests at the prime-contractor facility, the vehicle environmental tests (both thermal vacuum and vibration) at the NASA Manned Spacecraft Center (MSC), and the LM/CSM/MSFN RF-compatibility tests at MSC.

The program plan also included provisions for reliability, weight, electromagnetic-interference (EMI), design and development, spares, and program control.

Reliability control. - To attain the reliability goals, the basic design was optimized, and possible modes or sources of failure in the design were determined and corrected. After the design phase, equipment failures that were produced in the test

phases were analyzed to determine their effect on the equipment reliability, and the modifications necessary to correct the problems were incorporated. (For further details on system reliability, see the section entitled "System Reliability and Performance.")

Weight control. - During the early phases of LM development, weight minimization was a concept that greatly influenced the system design. Preliminary designs and weight estimates were examined to ensure that the weights and sizes of parts and components were minimized and to ensure that materials and packaging techniques were consistent. However, weight restrictions were eased as the payload capacity of the Saturn V launch vehicle became better defined and as some system equipment was improved. The most notable system change in this category was the pressurization of two electronic replaceable assemblies (ERA's) in the system. (See the section entitled "System Design and Analysis.")

Control of EMI. - The EMI-control plan included basic EMI-suppression techniques and cabling control and grounding control methods. Vendors were required to submit detailed EMI test plans for approval before testing. Equipment changes were monitored to determine their effects on EMI. In addition to the EMI requirements at the black-box level, EMI-compatibility tests of the LM/CSM/EVA equipment were planned and conducted.

Design and development control. - The design and development control plan included provisions for continuing review of all new design concepts, drawings, and specifications with representatives from the subcontractor engineering, reliability, and manufacturing organizations. Individual part serialization that permitted traceability of all processes, tests, inspections, and fabrication was required.

Spares control. - In the spares-control method that was developed during the Apollo Program, a replaceable-functional-assembly concept was used. During early system development, the spares plan included the use of the results of reliability failure analyses, maintenance analyses, and the past history of related hardware programs to determine the number of spares needed. Spares were located at the NASA John F. Kennedy Space Center (KSC) and the contractor facilities; a parts spare, which permitted quick-repair capability, was located at the subcontractor facilities.

Program control. - Program control is discussed in the following section.

Program Management

The program-management plan provided for MSC monitoring and control at all levels of the program. Flexibility and quick reaction were important because requirements constantly changed during critical program phases. The system-management structure is shown in figure 4.

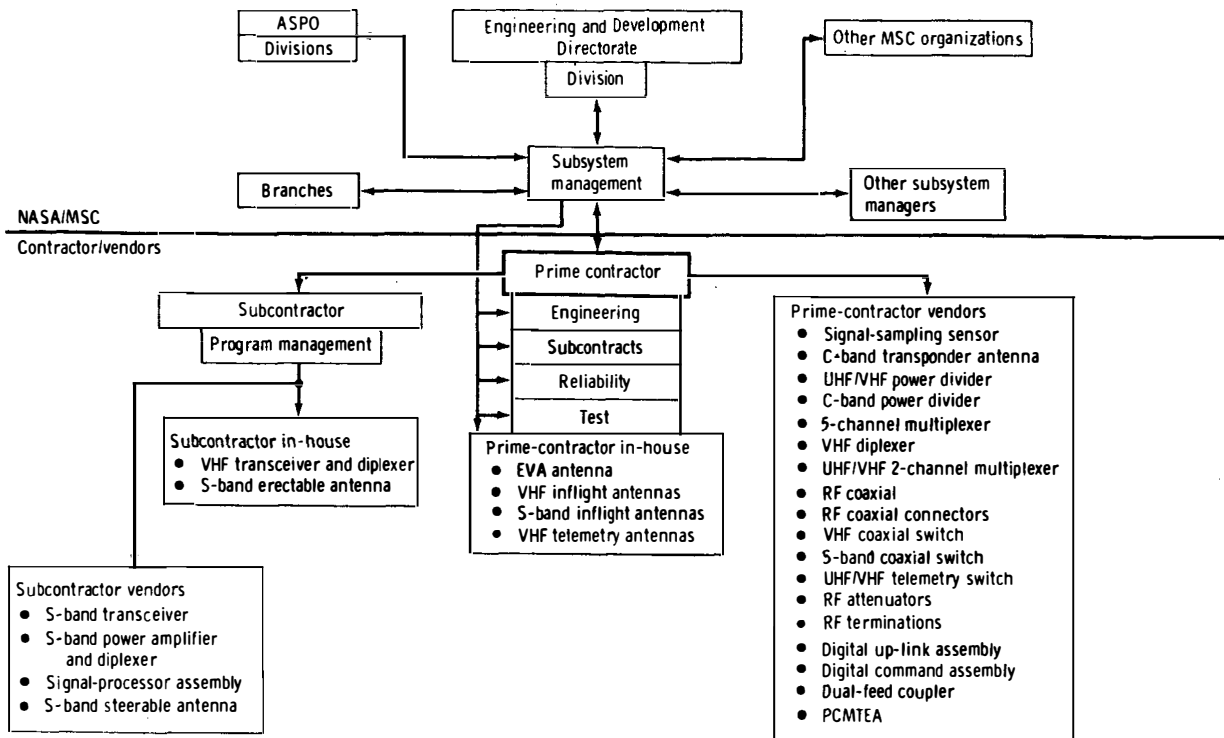

Note: ASPO - Apollo Spacecraft Program Office

Figure 4. - Lunar module communications and management structure.

Manned Spacecraft Center. - At MSC, management of the various subsystems was assigned to subsystem managers within the Engineering and Development Directorate. Each subsystem manager was responsible to the Manager of the Apollo Spacecraft Program Office (ASPO) for the successful management of schedules, costs, performance, reliability, weight, and other program aspects that are considerations in the timely delivery of quality hardware. The subsystem manager accomplished the tasks by associating with the actual engineering, manufacturing, and test efforts at both the prime-contractor and subcontractor facilities. Official direction to the contractor was given through the established ASPO channels.

The subsystem manager also participated in the preparation of specifications, test plans, and qualification and reliability criteria and in consultation and analyses, as required. In addition, coordination was required among the directorate and division and the individual project engineers in the branches. Coordination also was required with other subsystem managers and functional organizations within MSC.

During all phases of the program, many problems arose that required technical resolution between MSC and the contractor. The subsystem manager was responsible for the resolution of these technical problems with the contractor engineering subsystem manager. Work packages — which consisted of task delineation, manpower assignments, and schedules — were monitored at both the contractor and vendor facilities. Contract negotiations also were reviewed to ensure proper task direction and accomplishment within the guidelines set by MSC.

Prime contractor. - Management of the LM program was the responsibility of the prime contractor, who in turn assigned a major part of the communications system management to a subcontractor. Operational communications (except for the DUA, PCMTEA inflight and EVA antennas, cables, and connectors) were contracted to the subcontractor.

Establishing an organization similar to that of MSC, the prime contractor assigned responsibility for subsystem management within the engineering division. The subsystem manager was responsible to the project office for the development of the subsystem. Close association and cooperation were required with vendors and with manufacturing, ground-support, reliability, and vehicle-testing groups. During the conception, design, development, testing, and delivery of the communications equipment, primary emphasis was placed on working with the subcontractors. After the equipment was delivered, emphasis shifted to in-house coordination. After delivery of the LM to KSC, management emphasis shifted to monitoring the progression of the subsystem through KSC. During the various flight missions, system performance was monitored closely for adequacy of mission support and possible corrective action. During all phases of the program, technical actions were coordinated through the MSC subsystem manager. If changes to the subsystem were proposed after the design freeze, the engineering subsystem manager obtained project-management approval for submission of the changes to MSC for final approval.

Subcontractor. - The subcontractor Program Management Office (PMO) controlled the entire LM contract effort, including all prime contractor/subcontractor and subcontractor/subcontractor vendors contractual agreements. The PMO support groups prepared standards, policies, and general procedures for documentation, test programs and procedures, training, field support, engineering standards, and the reliability program. These standards, policies, and procedures were imposed upon all subcontractor vendors (including subcontractor in-house activities) and were used during the subsystem-integration activity at the subcontractor facility.

As the program developed, difficulties were experienced in maintaining efficient coordination between the PMO and the subcontractor in-house activities. These activities were of considerable importance to the subcontractor LM-communications effort and included system integration, VHF-transceiver development, and erectable-antenna development. By mid-1966, the PMO for communications was relocated within the subcontractor organization to reduce duplication of effort and to improve efficiency.

For each communication ERA, the project-engineering groups (within the PMO) developed requirements in conjunction with the prime contractor. The engineering groups reviewed and approved system specifications, set schedule milestones, approved cost estimates, employed management techniques to monitor and guide the progress of the program continuously, and took appropriate action to ensure the meeting of all objectives. They were responsible for all technical agreements with the prime contractor. All technical information flowed through the PMO project-engineering groups to the prime contractor. The project-engineering groups provided the technical and managerial link throughout the communications-system development from inception to final system delivery and acceptance by NASA. However, detailed design and development effort was not a PMO project-engineering function. The detailed design, procurement, production, and test implementation were the responsibility of in-house engineering groups and subcontractor vendor engineering groups.

SYSTEM DESIGN AND ANALYSIS

Past experience with Project Mercury and the Gemini Program demonstrated the feasibility of manned-spacecraft communications. The complexity of lunar missions, the public investment and interest, and the national and international significance of the flights increased the need for a reliable, comprehensive, and flexible communications system. The basic functional and performance requirements, as they evolved for the first lunar landing, are shown in table I.

TABLE I. - FUNCTIONAL AND PERFORMANCE REQUIREMENTS

Function	Performance required
Two-way voice	
LM/MSFN	Normal voice: 90-percent word intelligibility (design goal) Backup voice: 70-percent word intelligibility
LM/CSM	Normal voice: 90-percent word intelligibility; maximum range of 550 n. mi.
LM/EVA	Normal voice: 90-percent word intelligibility; maximum range of 1 n. mi.
EVA/EVA	Normal voice: 90-percent word intelligibility; maximum range of 0.5 n. mi.
Data-voice relay	Capability to relay data and voice from EVA to MSFN Capability to relay voice from CSM to MSFN
PCM telemetry	Maximum bit error rate of 1 in 10^6 bits (design goal), both high bit rate and low bit rate; capability to transmit low-bit-rate data to CSM; maximum range of 320 n. mi.
Biomedical data	Capability to transmit analog electrocardiogram from LM and relay through LM from EVA
Trajectory determination	Determination of trajectory by phase-coherent turnaround of PRN ranging code and integration of two-way RF Doppler data
VHF ranging	Capability to turnaround range tones to a range of 200 n. mi.
Up-link data and voice	Capability to receive discrete commands and complex digital information Probability of accepting an incorrect message: 10^{-26} Probability of rejecting a correct message: 10^{-3} Voice: 70-percent word intelligibility
Television	Capability to transmit video information with 500-kHz bandwidth
Emergency key	Copy accuracy: 70 percent at 25 characters/min

System Requirements

Environmental requirements depended upon equipment location. Except for the electronics package in the S-band steerable antenna, which was located outside the LM, the majority of the electronic equipment was in the aft equipment bay (fig. 5). In the original design concept, the pressure environment of the aft equipment bay was planned to be either atmospheric pressure or absolute vacuum (except during the short period when earth orbit was being achieved). However, as the LM design developed, the aft equipment bay was found to maintain a partial pressure that was in the corona region for electronic equipment. This finding brought about a revision of system requirements and necessitated extensive redesign in three of the ERA's.

Thermal requirements were based on operation of the ERA's on the water-glycol-cooled mounting rails in the aft equipment bay. The thermal requirements for ERA design were based on the cold-rail temperature, which varied between 35° and 135° F.

Vibration requirements were not well defined until LM vibrational tests were performed on a ground-test spacecraft with excitation levels based on data obtained

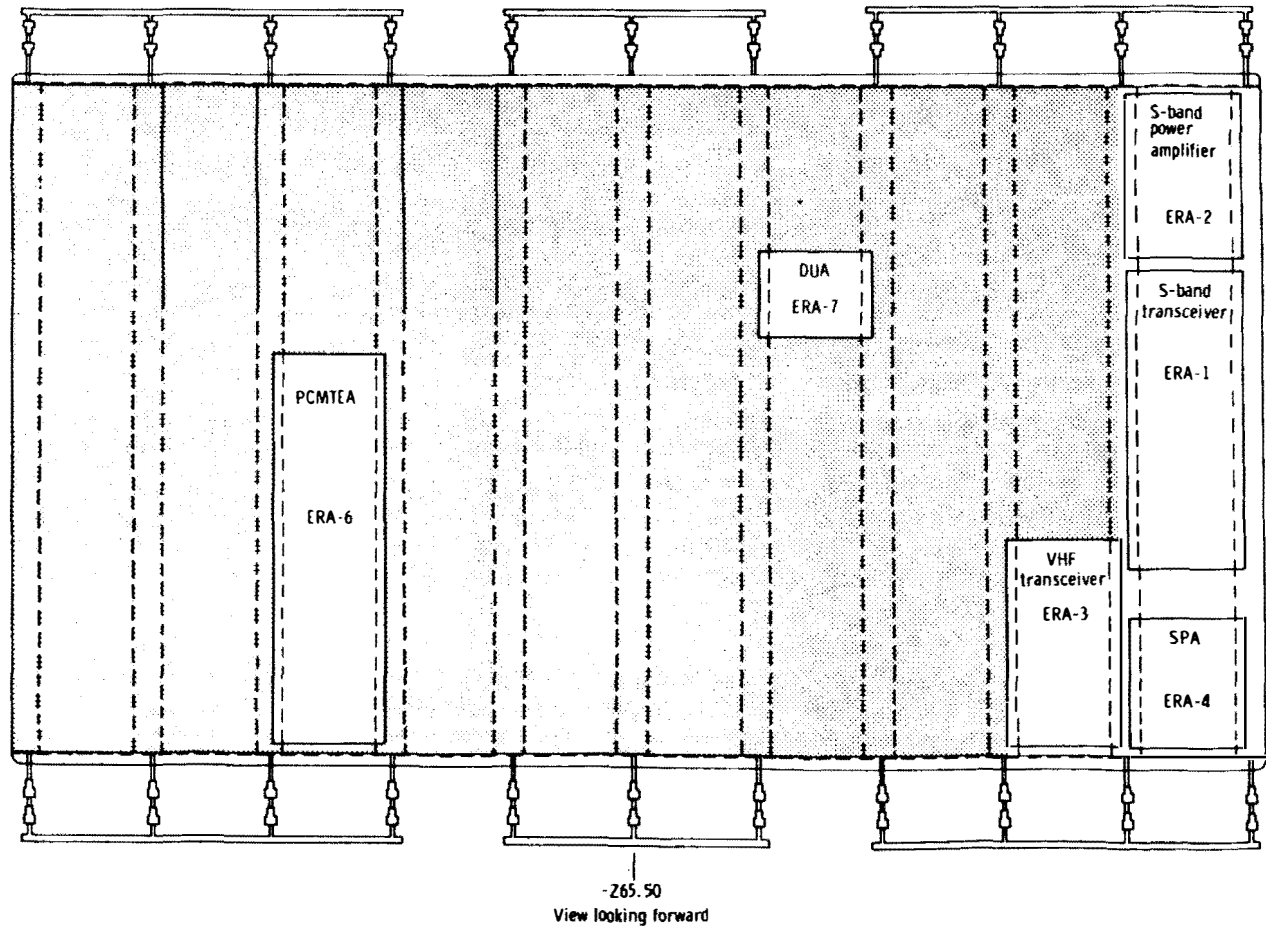

Figure 5. - Aft-equipment-bay cold rails and ERA arrangement.

during Saturn-development missions. Additional environmental requirements were established for humidity, fungus, sand and dust, explosion, shock, and acceleration.

More than any other factor, weight restrictions dictated the basic design of the LM communications system. Weight is directly related to power utilization and thus affects the electrical design. A 75-watt input to an ERA operating continuously for 24 hours would require batteries weighing approximately 40 pounds (assuming an approximately 45-W-hr/lb battery). This weight of 40 pounds would influence engine-thrust, fuel, and structural requirements, and the weight of the equipment in the LM ascent stage would be multiplied almost tenfold. As a result of the emphasis on weight reduction, the LM communications system was less than one-half as heavy and required one-fourth less power than the comparable portions of the CSM communications system.

Because of LM weight restrictions, the power budget was critical. Therefore, efficiency in power use was also a major factor influencing the system design.

When the LM contract was awarded, the CSM contract had been in effect for approximately 2 years, and the resulting knowledge was applied in the LM program. Therefore, the prime contractor was requested to use the same vendors for comparable ERA's. The vendors also were requested to retain the same basic design concepts and manufacturing techniques that were used for the CSM equipment. However, because of the more stringent weight and power restrictions, commonality was not generally maintained. For example, weight and power requirements made an amplatron-tube design more attractive than the traveling-wave-tube design used in the CSM. The amplatron-tube power amplifier weighed 16.8 pounds and required 72 watts; the CSM power amplifier weighed 32 pounds and required 90 or 167 watts, depending on mode selection. As a result of these increased requirements, only four ERA's were supplied by common vendors, and design concepts were not common with the concepts used in the CSM equipment.

The initial system requirements for functional switching of communication modes differed considerably from the system requirements that were finally used. As conceived, mode switching was to be accomplished with a selector switch. This procedure simplified the crew switching functions but provided less flexibility and required more complicated electrical switching. After crew review, greater flexibility in manual crew switching was incorporated in the design. This flexibility was implemented; however, it increased the complexity of mode switching and required a better understanding of the system by the crew. Redundancy became a requirement to increase system reliability and also required manual crew switching in most cases.

Electromagnetic-interference requirements were imposed to ensure compatible operation of the communications system with other equipment. Conducted and radiated EMI from the ERA's and associated components, as well as susceptibility of the system to EMI, was designed to be at the minimum levels imposed by EMI specifications.

Other operational requirements included interface compatibility with the electrical power system, the instrumentation system, the displays and controls, the environmental control system, the LM guidance computer (LGC), and crew personal equipment.

System Analysis

A basic tool for designing and analyzing the design of a communications system is the study of RF signal compatibility between communication points. In the following paragraphs, the techniques used in design of the LM communications system are described. A detailed discussion of S-band design analysis may be found in reference 1.

The VHF design analyses were of importance to the communications-system development. In addition to the standard parameters analyzed in other Apollo communications links, the VHF link between the LM and the CSM required consideration of polarization loss. Polarization purity of the LM circularly polarized antennas was poor as a result of the omnidirectional-coverage requirement, the limited size of the antennas, and the proximity of the irregular LM structure. The polarization impurity was a significant factor in determining the coupling between the LM antennas and the linearly polarized CSM antennas.

The polarization characteristics of the vehicle antennas must be known in reference to the vehicle coordinate axes. These characteristics can be determined from any four of the six interdependent polarization components radiated by an antenna. However, all polarization components were measured to simplify performance of manual calculations, if desired, during a mission.

If the vehicle radiation data, the look angle of each vehicle, and the relative attitudes of the vehicles about their common line of sight are known, the polarization loss can be calculated, and the performance characteristics of the communications link can be estimated. The adequacy of the communications link was evaluated by estimating the performance in the design-reference mission.

A support contractor used computer software to analyze each mission. The program was used to analyze the LM and CSM trajectories and vehicle-antenna radiation data to provide analyses of receiver signal strength compared to signal threshold for voice, data, and ranging. In the mission analysis report, proper antenna use was recommended for the various mission phases, and the expected performance quality was predicted. The report also provided circuit-margin profiles for each combination of LM and CSM antennas. The circuit-margin profiles enabled the MSC to determine the effects of any selection of antenna combinations desired.

The design and operation of the LM communications system are discussed in following subsections. Also, the developmental flight instrumentation (DFI) and the portable life-support system (PLSS) communications systems are described.

The transition from the original system configuration to the qualification-test configuration is discussed in the section entitled "Development." Major configuration changes after initial qualification are discussed in the section entitled "Significant Modifications and Problems."

System Design

The operational communications system was composed of seven ERA's, RF components, and antennas. These are described in the following paragraphs.

The S-band transceiver (ERA-1). - The S-band transceiver consisted of two identical phase-locked receivers, two phase modulators with driver and multiplier chains, and a frequency modulator. The nominal power output was 0.75 watt. The receivers and phase modulators provided the ranging, voice, biomedical data, emergency keying, and telemetry transmit and receive functions. The frequency modulator provided transmission of TV, telemetry, biomedical data, and voice communications. The S-band operating frequencies were 2282.5 megahertz for transmission and 2101.8 megahertz for reception.

The S-band power amplifier (ERA-2). - The S-band power amplifier consisted of two selectable amplitrons (each having a power supply) and an input-output isolator. When power amplification was required, the selected S-band power amplatron amplified the S-band transceiver output to a nominal value (measured at the ERA-diplexer output) of 18.6 watts through the primary amplatron or 14.8 watts through the secondary amplatron.

The VHF transceiver (ERA-3). - The VHF transceiver consisted of two receivers, two transmitters, and a diplexer. One transceiver provided a 296.8-megahertz channel (channel A) and the other a 259.7-megahertz channel (channel B) for simplex or duplex voice communications. Channel B also transmitted PCM data at the low bit rate and received biomedical data from an EV crewman. Channel B also received VHF ranging data, which then were retransmitted on VHF A to the CSM. The transmitter used a keyed on-off carrier AM and delivered an average of 3.8 watts RF at the diplexer output.

The SPA (ERA-4). - The SPA provided the interface between the various communications electronics and processed voice, telemetry, and biomedical signals. The SPA consisted of audio centers for the two crewmen and a premodulation processor (PMP). The PMP provided signal modulation and mixing, mode switching, and relay capability for transmissions from the CSM through the LM to the MSFN. The PCM data were routed to the PMP biphasic modulator, which controlled the phase of the 1.024-megahertz telemetry subcarrier. The 1.024-megahertz telemetry and the 1.250-megahertz voice and biomedical subcarriers were generated from the 512-kilohertz clock PCMTEA signal.

A speech-processing network linked to the narrowband phase modulation (PM) input of the S-band equipment provided backup-voice transmission capabilities. Received voice signals were routed through the PMP to the headset volume-control circuits in the audio centers. The VHF channel B input had high-pass and low-pass filters to separate voice and EMU data.

The PMP received hardline biomedical data selected by manual control from each crewman for S-band transmission. The PM mixing network and the FM mixing network processed the outputs of the 1.024- and 1.250-megahertz subcarriers, which were a composite of voice, biomedical data, telemetry data, and EMU data. Backup-voice, FM video, PM ranging, and emergency-key signals were not processed through the mixing networks but were supplied directly to the selected S-band modulator for base-band modulation.

An audio center for each crewman provided individual selection, isolation, and amplification of audio signals received and transmitted by the communications system. Each audio center contained a microphone amplifier, a headset amplifier, a voice

circuit, diode switches, volume-control circuits, and isolation pads. Audio signals were routed to and from the VHF A, VHF B, and S-band systems and to and from the intercom bus through the audio centers. The intercom bus, which was common to both audio centers, provided hardline communications between the crewmen.

The S-band steerable antenna (ERA-5). - The S-band steerable antenna was a 26-inch-diameter parabolic dish with sleeved dipoles over a ground plane; it provided a gain of 20.5 decibels on the transmit frequency. The antenna operated either manually or automatically and provided a coverage of 174° in azimuth and 330° in elevation. Once the antenna was positioned manually within the RF capture cone, which had a coverage of approximately 25° , it could be operated in the automatic-tracking mode. The steerable antenna transmitted and received communications data between the LM and the MSFN while the LM was in lunar orbit, during descent, and after landing. During EVA on the lunar surface, the erectable antenna was erected and placed in operation by the EV crewmen. The steerable antenna provided a backup link with the MSFN during this portion of the mission. During pre-ascent checkout, the steerable antenna was activated again and operated throughout the lunar ascent and during rendezvous and docking of the LM and the CSM.

The PCMTEA (ERA-6). - The PCMTEA processed signals from the various LM systems by using a preset format and the PCMTEA programer. After formatting and processing, the programer shifted the signals out of the register in a nonreturn-to-zero or split-phase serial format. The signals then were routed to the SPA for further processing on the appropriate communications channel.

The DUA (ERA-7). - The DUA received MSFN digital commands, which were modulated on the 70-kilohertz subcarrier and which allowed the MSFN to control the LGC. The DUA demodulated, decoded, and applied the commands to the LGC. The digital commands were parallel to those available from the LGC on the LM display and keyboard (DSKY). The DUA also provided capability for backup up-link voice on the same subcarrier.

With the exception of the S-band steerable antenna (ERA-5), all ERA's were mounted on cold rails in the LM aft equipment bay. The arrangement of the aft-equipment-bay cold rails and the ERA's is shown in figure 5. The cold rails, which were cooled by a glycol-water solution, maintained the ERA temperatures within the specified operating ranges by heat transfer from the flanges by which the ERA was mounted to the rails. The S-band steerable antenna was mounted at the end of a tripod boom, which was located on the LM starboard side (looking forward). Thermal paint and heaters controlled the steerable-antenna temperature.

In addition to the ERA's, the LM communications system consisted of RF coaxial lines, coaxial connectors, RF switches, and the following antennas.

The S-band erectable antenna was used for S-band communications between the LM and the MSFN after lunar landing. The erectable antenna was a manually unfolding assembly that consisted of a reflector, a feed assembly, an aiming device, a tripod, and an RF connection. The assembly was transported in quad area number 1 of the descent stage.

When erected, the antenna was a 10-foot-diameter parabolic reflector illuminated with RF energy by a pylon-mounted feed system; it provided a transmit gain of 34.0 decibels. The reflector, which was supported on an extendable tripod, was a flexible membrane attached to 21 folding, radial, spring-loaded parabolic ribs. The spring-loaded release was actuated by the EV crewman to unfurl the reflector after he had opened the tripod and pointed it approximately. The feed pylon was of trombone construction, and the tripod was hinged and collapsible.

Two S-band inflight antennas were used as backups to the steerable antenna. A spiral cut in the cone of each antenna produced right-hand circular polarization. The radiation pattern provided a minimum gain of -3 decibels (with respect to a circularly polarized isotropic radiator) over 85 percent of the spacecraft spherical area. This requirement was accomplished by manual switching between the two antennas.

Two VHF inflight antennas were used for communications with the CSM. The antenna was designed to produce right-hand circular polarization. The radiation pattern provided approximately 4π -steradian coverage with a minimum gain of -6 decibels (with respect to the CSM linearly polarized VHF antenna) when the antenna assembly was terminated in a free-space environment. This requirement was accomplished by manual switching between the two antennas.

The EVA antenna was deployed after lunar landing by use of a T-handle located in the LM cabin. The EVA antenna was a pencil-cone antenna consisting of an 8-inch monopole and a 12-inch, 10-radial modified ground plane with an included angle of 40° . The radiation pattern provided omnidirectional azimuthal coverage with a minimum gain of -3 decibels at 0° elevation. These gain magnitudes are with respect to a vertically polarized isotropic antenna with the EVA antenna in the erected position and terminating in a free-space environment. The EVA antenna was linearly polarized in a vertical plane.

The erectable antenna, the 30-foot cable, and the TV equipment were stowed in the descent stage. The remaining antennas were on the ascent stage of the LM and are shown in figure 6.

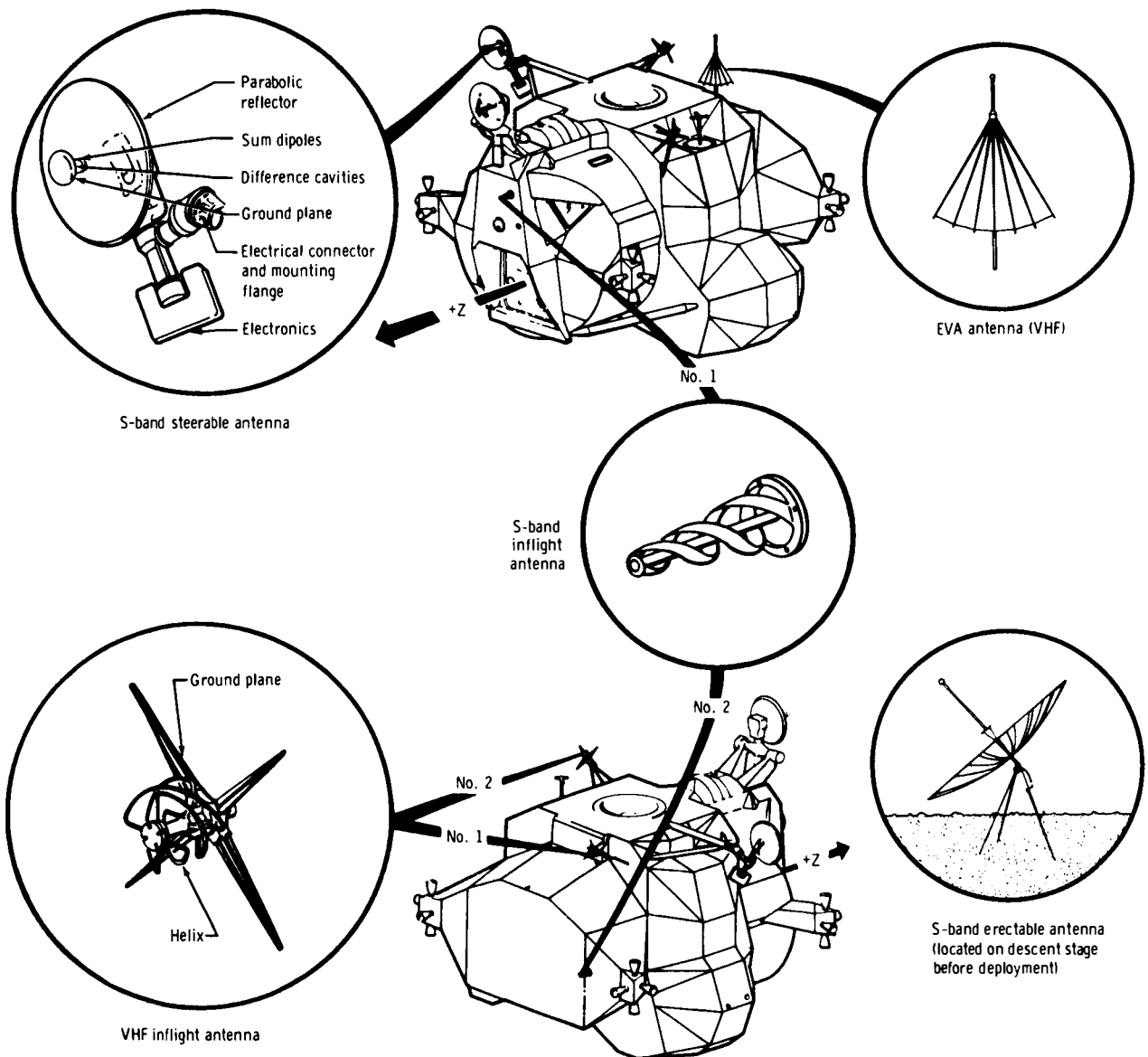

Figure 6. - Lunar module communications-system antenna locations.

System Operations

The relationships between the seven ERA's and the various antennas are shown in figure 7.

Audio inputs from the commander or LM pilot were hardlined to the respective audio centers located in the SPA. If a VHF transmitter was selected, the audio center routed the voice input to the correct VHF modulator and provided keying of the transmitter. After amplification to a peak power of approximately 7.6 watts, the signal was routed through the VHF diplexer to the selected VHF antenna. Any received RF signals

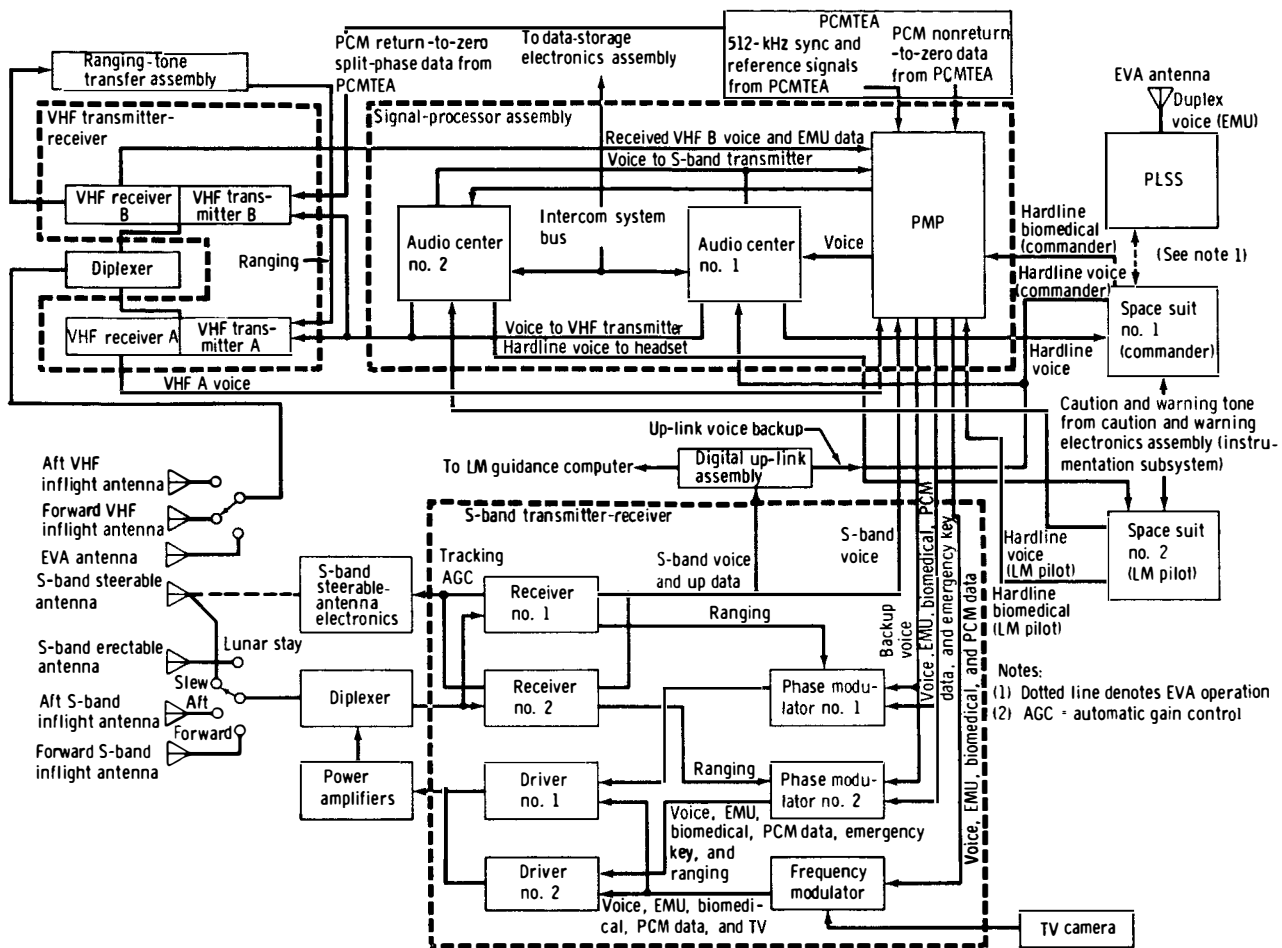

Figure 7. - Simplified block diagram of LM communications system.

were routed through the VHF diplexer to the receiver section. The detected output of the receiver was routed to the PMP in the SPA, which further amplified and routed the signal to the audio centers. The transmit/receive selector switches and volume controls on the crewmen's control panels controlled headset audio signals. The VHF communication modes between the LM and the CSM are shown in figure 1.

If the S-band equipment was selected, the audio input to the audio center was amplified and routed to the PMP, in which the 1.250-megahertz carrier was frequency modulated. The 1.250-megahertz SPA-subcarrier output was routed to the S-band transceiver, where the carrier was phase modulated or frequency modulated. The output was amplified in the S-band power amplifier and passed through the S-band diplexer to the selected S-band antenna. Normally, the steerable antenna was selected during in-flight operations. The steerable antenna had a gain of approximately 20 decibels. The erectable antenna, which had a gain of approximately 34 decibels, was the primary antenna used during the lunar stay. The two S-band inflight antennas were available as backups to the steerable antenna. Any received RF signal was routed through the S-band diplexer to the receiver section of the S-band transceiver. The detected PRN ranging code was applied internally to the transmitter modulator from the receiver. The

detected-voice subcarrier was processed in the PMP; then, the detected audio signal was routed to the audio centers for amplification and headset selection. The S-band communication modes between the LM and the MSFN are shown in figure 8.

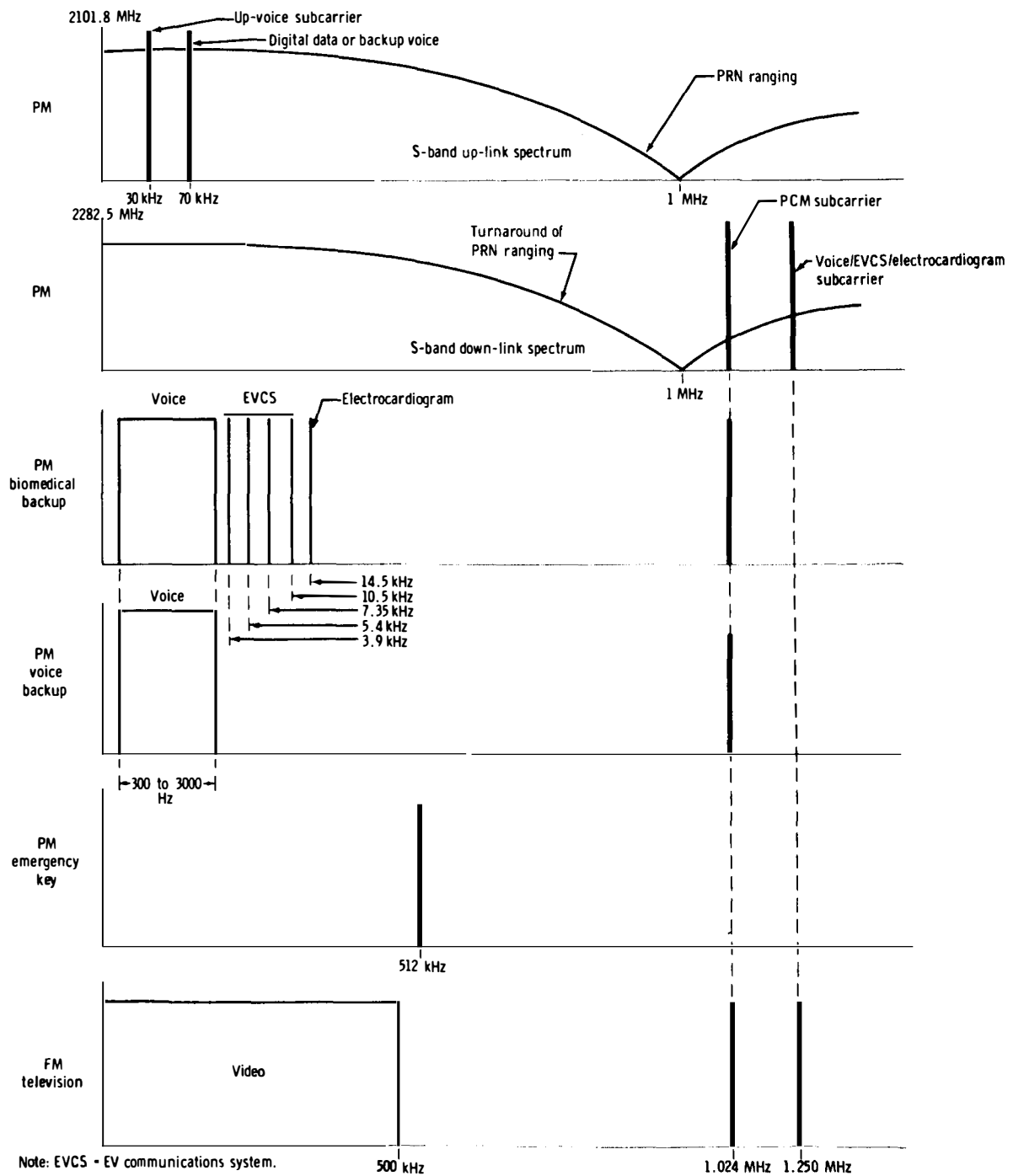
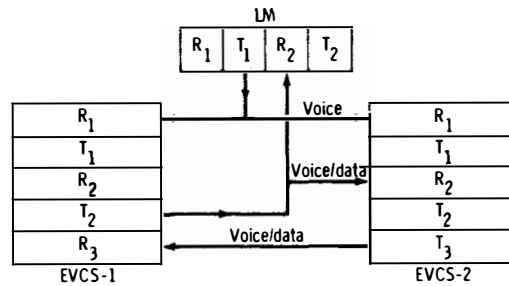

Figure 8. - Apollo S-band modes.

During lunar stay, both the VHF EVA antenna and the S-band erectable antenna were used. Video signals from the TV camera were routed directly to a frequency modulator in the S-band transceiver for transmission to the MSFN by the erectable antenna. The MSFN voice signal was received in the LM and relayed to EV communications system unit 1 (EVCS-1) and EVCS-2 by VHF A. During EV communications to the MSFN, EVCS-2 voice and data were transmitted to EVCS-1 over an FM link and were combined with EVCS-1 voice and data. Then, the combined signal was transmitted by VHF B to the LM where it was processed and relayed to the MSFN. The LM PCM data and TV signals could be transmitted simultaneously with the EVCS voice and data. Lunar-surface communications links are shown in figure 2. Detailed operational modes of the EVCS units are shown in figure 9.

$R_1, T_1 = 296.8$ MHz, channel A
 $R_2, T_2 = 259.7$ MHz, channel B
 $R_3, T_3 = 279.0$ MHz, channel C



(a) Dual mode.

$R_1, T_1 = 296.8$ MHz, channel A
 $R_2, T_2 = 259.7$ MHz, channel B
 $R_3, T_3 = 279.0$ MHz, channel C

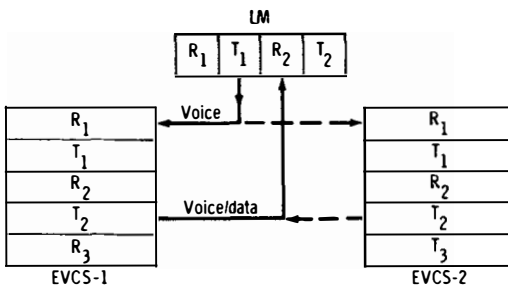

(b). Primary backup mode.

$R_1, T_1 = 296.8$ MHz, channel A
 $R_2, T_2 = 259.7$ MHz, channel B
 $R_3, T_3 = 279.0$ MHz, channel C

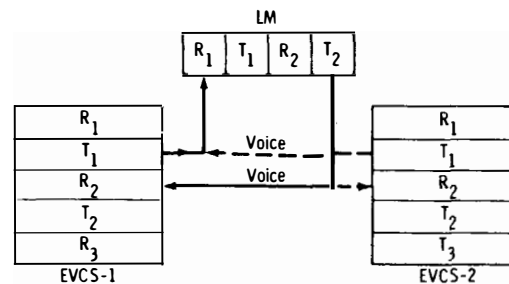

(c) Secondary backup mode.

Figure 9. - Extravehicular-communications-system modes of operation.

Signals from system sensors were applied to the PCMTEA for conversion to a PCM-data format. During LM/MSFN line of sight, the PCM nonreturn-to-zero data were routed to the PMP for modulation and transmission on the S-band. Behind the moon, low-bit-rate split-phase PCM data were transmitted to the CSM on VHF and were recorded. Real-time telemetry measurements on LM communications equipment are listed in table II.

All voice signals on the LM intercom bus could be recorded by the data-storage electronics assembly (a voice tape recorder) in the instrumentation system.

TABLE II. - REAL-TIME TELEMETRY MEASUREMENTS

Measurement	Range			Sample/sec	Bit rate	
	Low	Norm	High		High	Low
DUA up-link verify word	--	--	--	50	X	--
S-band steerable-antenna temperature	-67° F	--	+153° F	1	X	X
Static phase error	-15°	0°	+15°	10	X	X
S-band transmitter RF power	.5 W	.75 W	1 W	1	X	X
S-band receiver AGC	0 V dc	--	4.2 V dc	1	X	X
EVCS data	--	--	--	(Analog)	--	--
Electrocardiogram	--	--	--	(Analog)	--	--
PCMTEA internal oscillator failure-detect signal (3)	--	--	--	(Event)	X	X
PCM calibration voltage (85 percent)	0 V	4.25 V	5.0 V	10	X	X
PCM calibration voltage (15 percent)	0 V	.75 V	5.0 V	10	X	X

Digital up-link commands, which modulated the 70-kilohertz subcarrier, were received by the S-band transceiver and routed to the DUA for decoding. These commands were parallel to the LGC inputs and allowed the MSFN to provide data to the LGC. Capability for up-link backup-voice transmissions also was provided on the 70-kilohertz subcarrier. The backup-voice signal was routed to the commander's audio center by a path that was separate from the normal-voice-processing path. The LM/MSFN/CSM/EVA communications links are listed in table III.

TABLE III. - COMMUNICATIONS LINKS

Link	Data	Band	Mission phase	Purpose
MSFN/LM/MSFN	PRN ranging code	S-band	In flight	Ranging and tracking by MSFN
MSFN/LM	Voice	S-band	In flight and lunar stay	
MSFN/LM	Digital up link	S-band	In flight and lunar stay	Update LGC and backup voice
LM/MSFN	Voice, biomedical, PCM, telemetry	S-band	In flight	Commands, electrocardiogram, and LM status
LM/CSM/LM	Voice	VHF	In flight	
LM/CSM	Low-bit-rate split-phase data	VHF	In flight, far side	Future transfer CSM/MSFN
LM/EVA/LM	Voice	VHF	Lunar stay	
EVA/LM	EMU data	VHF	Lunar stay	PLSS status and electrocardiogram information relayed in real time to MSFN
CSM/LM/CSM	Ranging tones	VHF	In flight	Rendezvous radar backup
LM/MSFN	Voice, biomedical, EMU, TV, and PCM telemetry	S-band	Lunar stay	
LM/CSM/MSFN	Voice	VHF/S-band	In flight	Conference
LM/MSFN/CSM	Voice	S-band	In flight and lunar stay	Conference
EVA/LM/MSFN	Voice	VHF/S-band	Lunar stay	Conference
CSM/MSFN/LM/EVA	Voice	VHF/S-band	Lunar stay	Conference

Developmental-Flight-Instrumentation Communications

During the earth-orbital LM developmental flights, DFI was required. These flights were instrumented more heavily than the lunar operational flights and required more transmission channels. All developmental flights were in earth orbit; thus, VHF/UHF could be used for data transmission. A C-band radar was used to track the spacecraft. Telemetry transmitters and C-band-radar transponders were supplied to the prime contractor as Government-furnished equipment. The remainder of the equipment, supplied by the prime contractor, was as follows.

1. Digital-command assembly (DCA)
2. Dual-feed coupler (DFC)
3. Signal-sampling sensor
4. Five-channel multiplexer
5. VHF/UHF two-channel multiplexer
6. VHF/UHF power divider
7. VHF/UHF telemetry switch
8. C-band power divider
9. RF coaxial cable
10. RF coaxial terminations and connectors
11. VHF telemetry antennas (two in the LM, two in the spacecraft-LM adapter)
12. Four C-band transponder antennas

The LM/MSFN DFI communications links are shown in figure 10. Lunar modules 1 and 3 were the only lunar modules that used these frequencies. With the exception of the DCA, which was modified and renamed the DUA, all equipment in the DFI communications system was removed after the LM-3 flight.

A block diagram of the DFI equipment is shown in figure 11. The DFC was an active device at the output of the PCMTEA. The DFC had two isolated-output PCM signals that allowed simultaneous transmission of operational telemetry data on the S-band and VHF links.

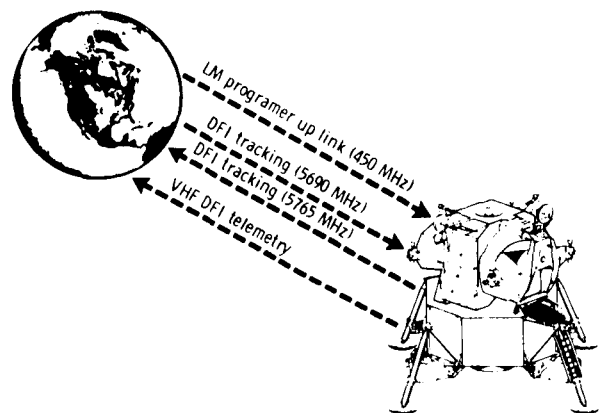

Figure 10. - Developmental-flight-instrumentation communications between LM and MSFN.

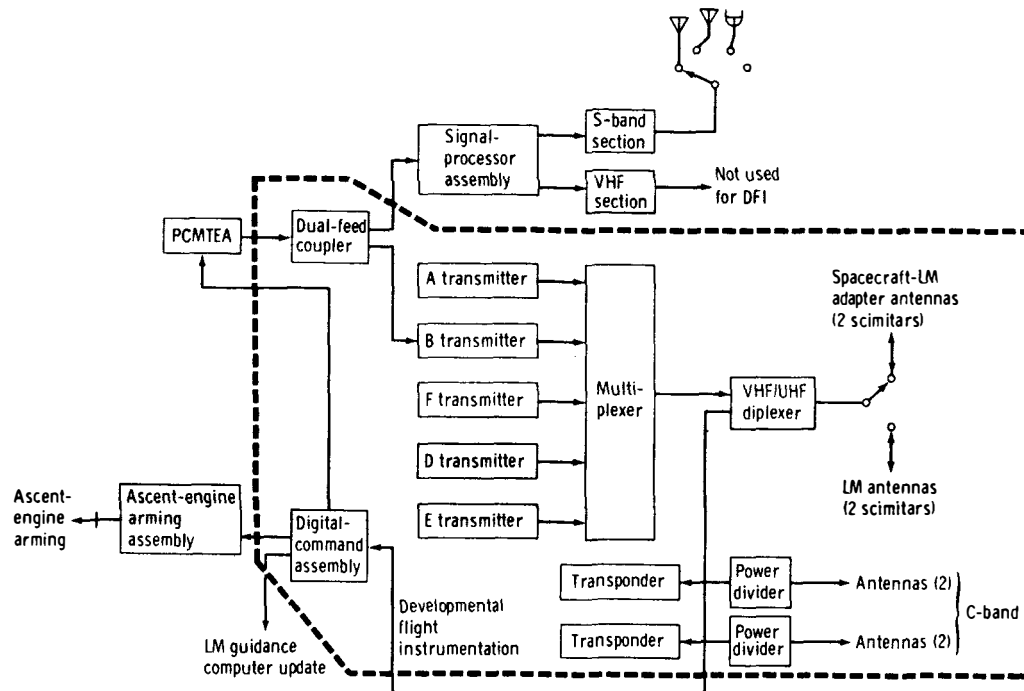

Figure 11. - Lunar module communications DFI equipment.

Transmitter B (of the five VHF DFI transmitters) accepted the DFC output; transmitters A, F, D, and E accepted various DFI modulation-packed outputs. The transmitter outputs were routed through a multiplexer, a diplexer, and the VHF/UHF scimitar-antenna system.

Two C-band transponders and four C-band antennas provided the MSFN with ranging data during the earth-orbital missions. The PCM VHF DFI down link and the C-band ranging were prime functions of the system; S-band PCM transmissions and the S-band ranging were secondary functions.

The DCA on the developmental vehicles received up-link commands from the 450-megahertz receiver. The DCA provided the MSFN with capabilities for commands and updating of the LGC and allowed ascent-engine arming for the final burn after crew egress.

Portable Life-Support System Communications

Early in the Apollo Program, the need was recognized for a crew communications system for use during EVA. Feasibility studies and production of breadboard hardware were begun, and provisions for integrating a personal communications system into the life-support system were made. In 1963, a PLSS-development contract was awarded. The PLSS was to provide all the life-support requirements of the EV crewman and was to include the personal communications system, which was later to be termed the space-suit communicator (SSC).

Space-suit communicator. - The SSC was the first system developed for lunar-surface communications. The SSC provided duplex-voice communications between one EV crewman and the spacecraft. The CSM or the LM was used as a relay station for communications to the MSFN. A completely redundant duplex-voice communications system was provided as a backup. The following channels of FM/AM telemetry data were processed and transmitted with the voice communications.

1. Electrocardiogram
2. PLSS-oxygen pressure
3. Suit pressure
4. Suit-water inlet temperature
5. Suit-water temperature differential
6. PLSS-feedwater pressure
7. PLSS-battery current or voltage

The SSC had solid-state components and was of a welded-cordwood construction. The SSC weighed approximately 4.5 pounds and used 10 watts at 15 to 20 volts. The RF output power was 75 milliwatts. After successful use on the Apollo 9 flight, the SSC was replaced by the EVCS.

The EVCS. - Early in 1967, the Apollo Program requirement that provided for a single EV crewman to work on the lunar surface was changed to include two crewmen. The SSC had allowed only one crewman to transmit voice and space-suit telemetry to earth through the LM relay, and the SSC could not be modified reasonably to provide simultaneous voice and telemetry from two crewmen. Therefore, a new approach to EV communications was sought. Ultimately, a satisfactory system was devised by use of a relay technique. In essence, the first EVCS transmitted voice and data to the second EVCS. Then, the combined EVCS-1 and EVCS-2 voice and data were relayed to the LM by the second EVCS. The system parameters and tolerances were chosen carefully because of extensive use of relay techniques. The EVCS concept was developed by the MSC to satisfy the following program requirements.

1. No changes were to be made in the existing LM communications system.
2. Continuous telemetry data were to be relayed simultaneously to the MSFN from each of the two EV crewmen.
3. Duplex-voice communications were to be transmitted between the MSFN and at least one of the crewmen.
4. Uninterruptible voice communications were to be transmitted between the crewmen.
5. The required range was to be 1 mile from the LM and 0.5 mile between crewmen.

6. The telemetry channels would be increased to a minimum of 13.
7. Program schedules would be met.

Modes and manner of EVCS operation on the lunar surface are shown in figures 2 and 9. Exactly 2 years after the award of the EVCS contract (July 1967), the first lunar landing was performed (July 1969). Because the EVCS was to be used first on Apollo 11, a thorough test program was pursued to ensure 100-percent reliability for mission success.

Six prototype units were built with commercial parts in the contractor's model shop. These units were used to support the MSC evaluation tests, crew training, PLSS qualification, and the prequalification tests. A structural problem, which was discovered in the telemetry model during prequalification tests, was corrected for the qualification and flight EVCS models. One qualification model was fabricated with high-reliability parts and passed the qualification program. The flight models were identical to the qualification model.

Each EVCS was acceptance tested at the contractor's facilities. Acceptance tests included base-line ambient, thermal, vibration, and final bench tests. The units were shipped to the MSC, where a preinstallation acceptance test was performed before the units were installed in the PLSS. Then, the PLSS assembly was tested in several manned and unmanned vacuum-chamber runs. Interface tests with the associated spacecraft were performed at KSC to evaluate the total communications link.

A method was required for operationally checking the PLSS communications system before egress from the LM. Because the RF radiation characteristics inside the LM were unknown, a hardline connection between the PLSS and the LM VHF transceiver was proposed in the latter part of 1964. The hardline was used (before opening the hatch) to check the communications modes that would be used on the lunar surface. The hardline consisted of a panel connector with a short coaxial adapter cable to connect the PLSS VHF directly to the vehicle VHF. Subsequently, tests verified that the PLSS communications system could radiate inside the LM, and the hardline was not used during a mission.

DEVELOPMENT

In this section, the development of the LM communications system from the original system concept to the configuration of the system established at the time of the original qualification tests is discussed. Many changes were made to the system. Minor changes at the subassembly level are too numerous to mention. Therefore, only changes of major importance at the system and ERA level are discussed.

System Development

The communications subcontractor submitted the original system proposal to the prime contractor in August 1962. The technical proposal suggested a 10-watt VHF/AM transmitter operating in the region of 225 to 300 megahertz through a diplexer to an

omnidirectional antenna. The same omnidirectional antenna also was to be used for the signal received from the CSM, and this signal was routed to a single LM receiver through a diplexer. The anticipated nominal range was 450 nautical miles (1000 nautical miles for emergency use). During lunar stay, another transceiver that used an LM voice FM/VHF transmitter with a carrier frequency of 72.9 megahertz was proposed. The transmitter power was 2 watts, which was routed through another diplexer to an omnidirectional antenna. The link was proposed for EV use only and had an expected range of 3 miles. The EV signal was to be received on the LM omnidirectional antenna at a frequency of 121.5 megahertz. Voice, biomedical, and environmental data would be received on the FM receiver.

The S-band section of the system consisted of two S-band PM transceivers; one of the transceivers was used as a standby during descent and on the lunar surface. Voice, telemetry, or both could be transmitted to the MSFN through a low-power exciter and a 2-foot-square, gimballed, quad-helix antenna. Emergency-voice capability that used an omnidirectional antenna, either of the two redundant 20-watt amplatron power amplifiers, and the 85-foot-diameter earth-antenna system was proposed. On the lunar surface, a 10-foot-diameter erectable antenna used with either power amplifier permitted simultaneous transmission of TV, voice, and telemetry to earth.

A control console accepted dual voice inputs, 32- or 16-kbps nonreturn-to-zero data, portable TV, closed-circuit TV, tape-recorder output, and S-band and VHF signals. The console provided intercom capability between the crewmen in the LM. The outputs from the console provided voice, high- or low-bit-rate data, or TV to the S-band system and voice to the VHF sections. The console relayed VHF EV signals to the MSFN on the S-band and provided visual displays in the LM.

By June 1963, the communications system had evolved to a concept that contained (1) one ERA with a VHF transceiver, an SPA with two audio centers, and a signal conditioner and (2) a second ERA containing an S-band PM transceiver, a combination S-band PM/FM transmitter, and a single-amplatron-tube S-band power amplifier. A test program that required the second-tier vendors to supply subassemblies to the subcontractor for integration and testing was developed.

The prime contractor and subcontractor both evaluated infinite speech-clipping for use in VHF operations, and the subcontractor investigated light intensifiers for TV. (Television was contractor-furnished equipment at this time.)

In July 1963, engineering analyses were made of such concepts as using an S-band up-data link and an S-band system for rendezvous, leaving S-band equipment and the VHF lunar-stay antenna on the lunar surface, increasing the gain of the steerable antenna, eliminating the erectable antenna, using wire wrapping instead of soldering, and eliminating the transmission of taped data. For various reasons, most of the concepts were not accepted.

On October 7, 1963, the subcontractor submitted a formal technical proposal to the prime contractor. The contract for the LM communications system was awarded to the subcontractor on February 13, 1964. A block diagram of the proposed system is shown in figure 12. The proposal retained the two-ERA concept and included the steerable-antenna electronics in the S-band ERA. The VHF omnidirectional antennas remained, but a VHF lunar-stay antenna was added for communications with the CSM.

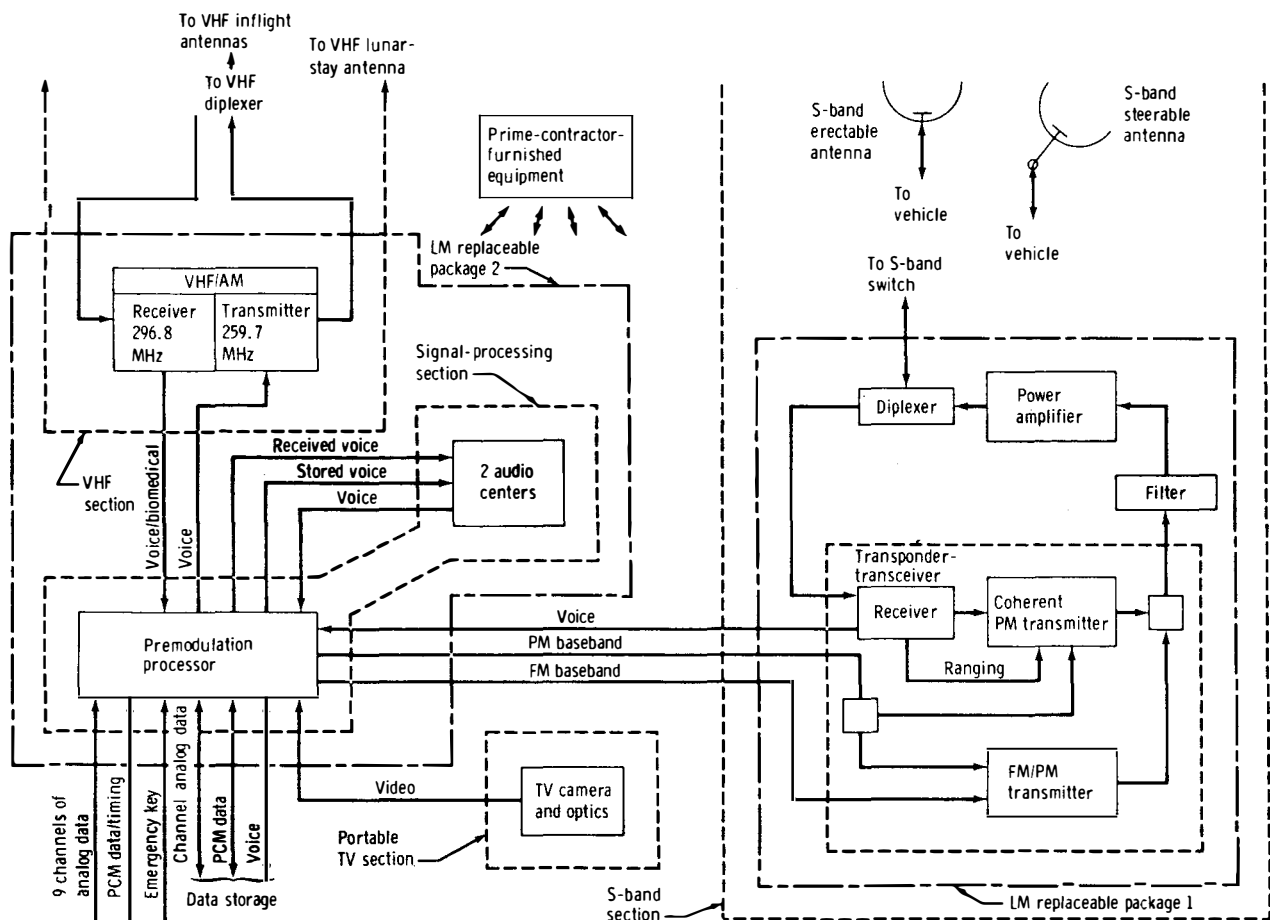

Figure 12. - Block diagram of LM communications system (subcontractor proposal of October 1963).

The VHF-transmitter and VHF-receiver frequencies were changed so that voice and data from EV crewmen were received on 296.8 megahertz. Voice transmission was on 259.7 megahertz. The SPA received and processed voice, PCM and analog data from the LM tape recorder, and video from the TV camera.

The subcontractor awarded a contract to its vendor for the infrared earth-tracker steerable antenna on July 6, 1964. The infrared sensor proved impractical because of plume effects, structures in the field of view, and the sun in the field of view; RF tracking was substituted in March 1965.

In addition to the S-band steerable antenna for inflight use, a 10-foot-diameter erectable antenna for communications to the MSFN from the lunar surface was included. The S-band electronics included a PM transceiver and a PM/FM transmitter.

As the LM program developed, changes in the requirements for the Block II CSM interface, mission planning, reliability, and quality affected the LM communications system. Also, engineering analyses continued with the objective of developing a better

communications system. These activities resulted in the major contract-change authorization 61 (CCA-61), which contained the following significant changes and additions.

1. Addition of a relay capability for CSM/LM/MSFN voice
2. Addition of a voice-conference capability among the CSM, the LM, and the MSFN
3. Addition of LM low-bit-rate PCM-transmission capability to the CSM
4. Increase of the range requirement for VHF voice to a maximum of 550 nautical miles
5. Addition of a second VHF transmitter and receiver
6. Addition of a third VHF low-power transmitter
7. Addition of a VHF EVA antenna and designation of the existing VHF omnidirectional antennas for inflight use only
8. Addition of a VHF triplexer
9. Designation of voice and telemetry to the MSFN as essential to mission success
10. Addition of low-bit-rate telemetry by the S-band without the power amplifier for power conservation
11. Provision for a pregress EV checkout
12. Provision for redundancy in the S-band section, including a redundant PM modulator and power supply and a redundant amplatron tube and power supply
13. Modification of the emergency-voice capability from FM to PM
14. Modification of various voice-processing circuits in the SPA

A block diagram of the system, showing the equipment changes that resulted, is shown in figure 13. The two-ERA concept remained the same; however, the size of the packaging envelope increased as a result of adding the redundant channels (fig. 14).

Because of the many changes that had taken place, schedules became critical. The need dates at the prime-contractor facility remained relatively stable, but the delivery dates on the communications equipment were being extended. During a program review, it was determined that ERA's could be available approximately 4 months earlier and that costs could be reduced if each vendor packaged his assembly into a functional ERA. Because of these program advantages, the functional ERA concept was adopted.

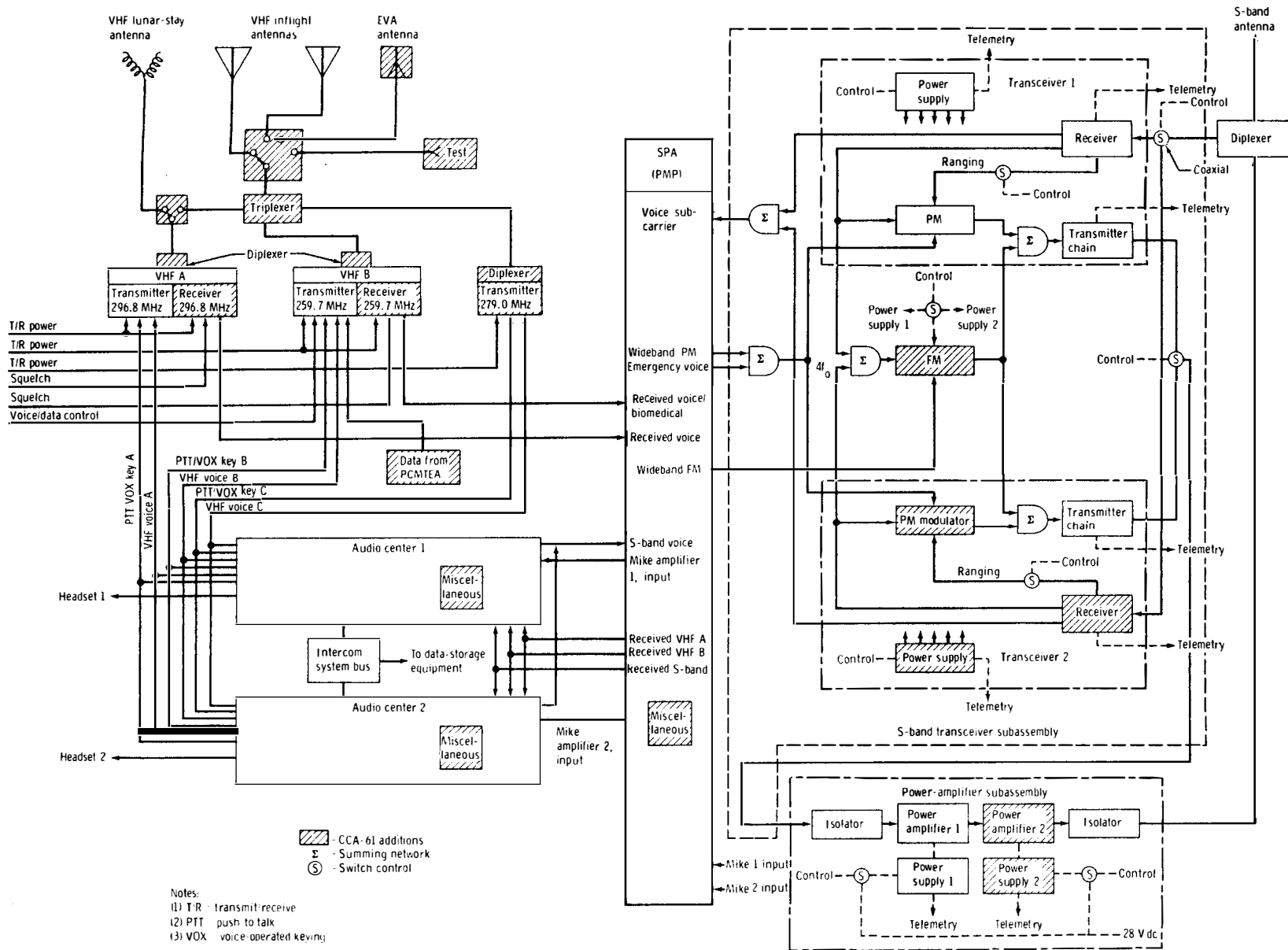

Figure 13. - Block diagram of LM communications system after CCA-61.

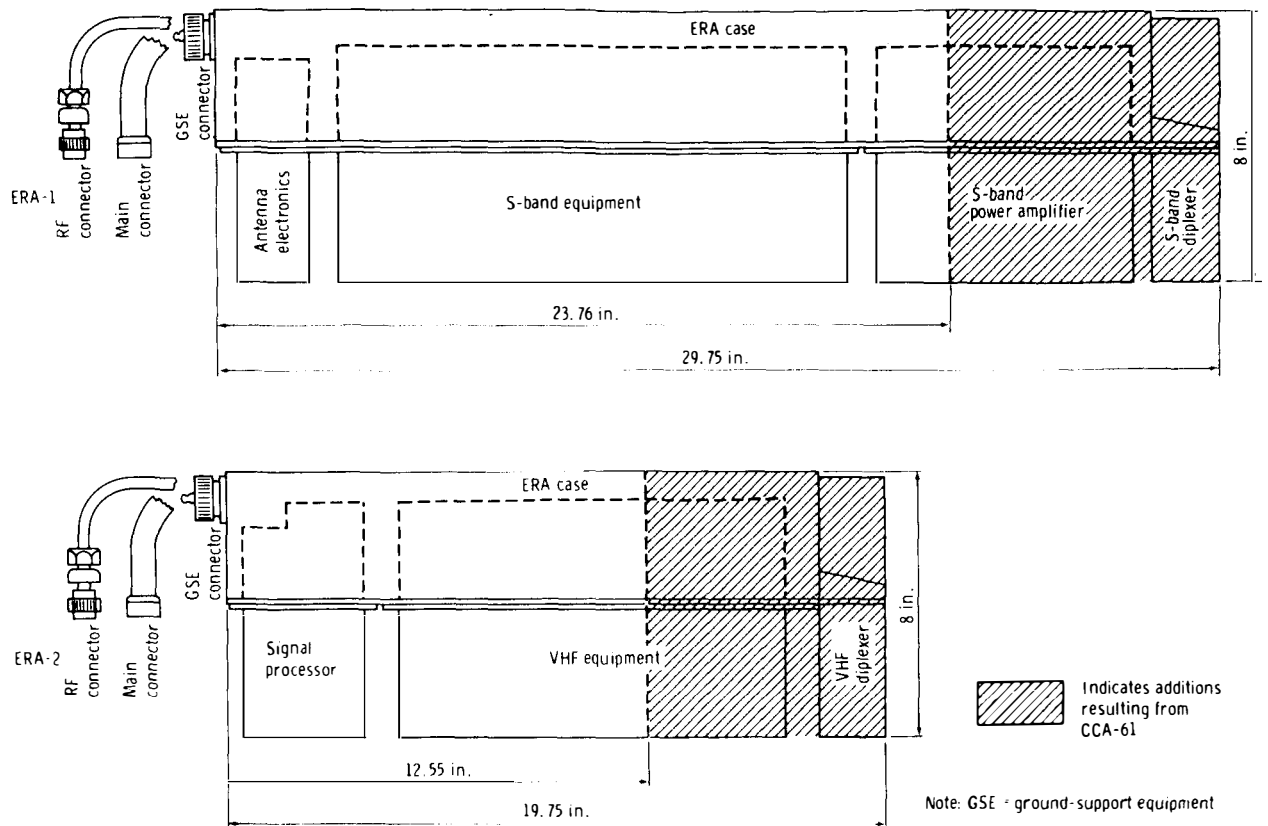

Figure 14. - System packaging after CCA-61.

Using the two-ERA approach, vendors would develop functional assemblies and perform design-verification and qualification testing. Subassemblies then would be delivered to the subcontractor to be integrated into the two ERA's. The subcontractor then would perform development and qualification tests. Flight ERA's would undergo acceptance tests at the subcontractor facility and be delivered to the prime contractor for installation on flight spacecraft.

Under the functional ERA concept, qualification testing would be performed by each vendor. Then, the flight articles would be acceptance tested and shipped directly to the prime contractor. The effect of this change improved program schedules in the test program and in the manufacture of the flight hardware.

As the system design evolved, the testing philosophies and concepts changed accordingly. These changes affected equipment, manufacturing, and vendor-facilities planning. Qualification tests on the ERA's began in June 1966. By that time, the system design had incorporated the following significant changes.

1. The two-ERA concept was changed to a functional ERA concept.
2. The steerable-antenna electronics were moved onto the antenna.

3. The third VHF transmitter was eliminated.
4. The VHF lunar-stay antenna was eliminated.

A block diagram of the system at the beginning of qualification tests on the ERA's is shown in figure 15.

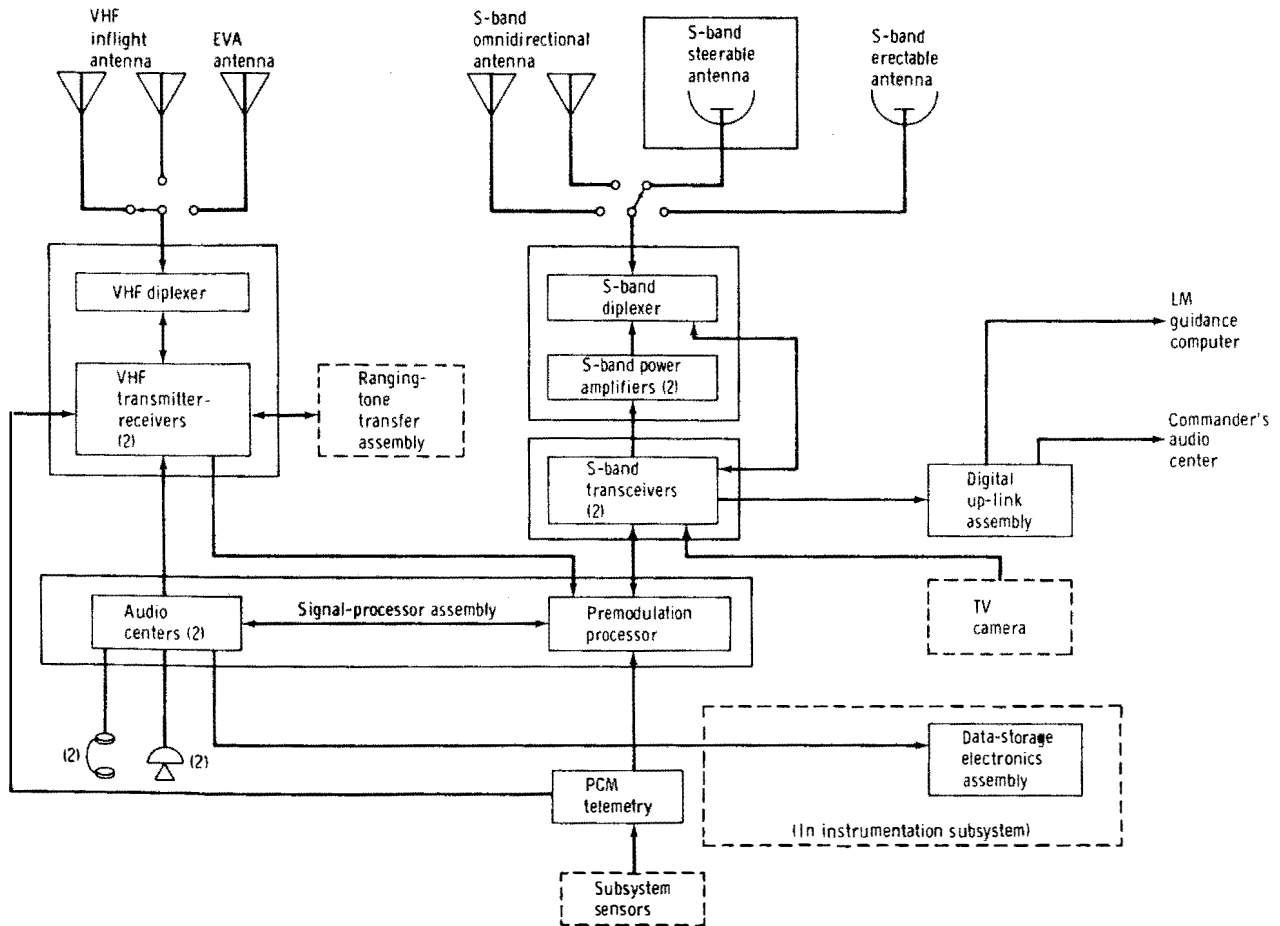

Figure 15. - Lunar module communications system.

Electronic Replaceable Assembly Development

The S-band transceiver. - In the original conception, the S-band transceiver had a completely solid-state design with a phase-locked receiver, a PM transmitter, and an FM transmitter. The design made maximum use of functionally proven circuits and components with demonstrated reliability. Circuits and components from the CSM transponder were used when possible. The proposed transponder and the CSM transponder differed principally in packaging and the primary power source (28 volts dc on the LM). Emphasis was placed on minimizing the size and weight of the LM unit. The

PM and FM/PM transmitters had a 0.75-watt output, which was sufficient to drive the amplifron power amplifier to full output power. The PM transmitter operated in a coherent mode and received excitation from the phase-locked receiver. The noncoherent FM/PM transmitter was primarily for the transmission of TV and emergency voice. Except for the modulators, the PM and FM/PM transmitters were identical.

Redundancy was provided in the functional concept by adding a coherent-transponder phase modulator, an additional power supply, an additional input switch, and an additional receiver. After the redundancy modification, the most significant change was that of repackaging to a pressurized ERA to eliminate a chronic corona problem.

The S-band steerable antenna. - The proposed design of the steerable antenna used an array of six right-hand circularly polarized helical elements in a hexagonal pattern around a central helical element. Because of vibrational problems, this design was changed to the current design, which is a 26-inch-diameter parabolic dish.

Also proposed was a design for an antenna using an infrared earth tracker. The design was changed to one for an antenna using an RF tracker to increase accuracy and to eliminate tracking of other infrared bodies (for example, the vehicle, the moon, or the sun). The RF tracking system was reconsidered after the invention of a new feed system and because of the higher reliability, the wider acquisition angle for a single-beamwidth antenna, the potential use in earth orbit, and the lower weight.

The original-design antenna included a stow-latch mechanism, which consisted of a pin in the main-gear assembly that was to be removed during flight by a pyrotechnic device. After the restriction of the use of pyrotechnic devices, the design was changed, and a meltable solder ring was used in conjunction with a spring-loaded pin in the gear assembly.

The S-band power amplifier. - The S-band power amplifier was a package that incorporated a QKS 997A amplifron tube, a solid-state dc-to-dc converter, and associated RF circuitry (such as circulators and RF filters). An RF output of 20 watts was expected, with a total dc input of 52 watts. Control circuitry was incorporated as a part of the dc-to-dc converter. Reliability was ensured by the use of components that were carefully selected and screened and by the use of conservative circuit and thermal designs. The amplifron tube was chosen because of the following characteristics.

1. High efficiency (requiring less dc power and cooling)
2. Ruggedness
3. Simplicity
4. The RF feedthrough when the tube was turned off (thus allowing control of the tube by dc switching to the power supply and eliminating RF switching)
5. Redundancy (which retained the fail-safe condition of RF feedthrough with both tubes off and which could be obtained by using two tubes in series)

The amplatron tube was developed for the JPL. It was expected that, by late 1963, a fully space-qualified tube would be available. Vibrational problems were encountered with the original amplatron tube (QKS 997), and development of the QKS 1300 began. However, early amplatrons of this type exhibited unstable operating characteristics and very limited life. Some of these problems were isolated in the power-supply control circuitry and in the cathode-mount design. In 1965, a product-improvement program began; the program included a quality-control audit to determine whether materials, processes, and techniques were consistent with good manufacturing practices and LM requirements. Failures then could be traced to the design rather than to inconsistent manufacturing procedures. Four subsequent design changes and strict quality control improved amplatron performance. Redundancy was included in the subassembly with the addition of a second amplatron, a power supply, and the required controls. Subsequently, the most significant change was the pressurization of the ERA to eliminate a chronic corona problem.

The DUA. - The DUA was developed from the DCA described in the section entitled "System Design and Analysis." The DCA demodulator and decoder were combined with a 70-kilohertz discriminator to form the DUA-data section. An audio amplifier and associated circuitry also were added to accommodate up-link voice on the 70-kilohertz subcarrier. The DUA received signals from the output of the existing S-band transceiver.

The PCMTEA. - The PCMTEA was redesigned in 1966 as a result of the LM weight-reduction program. A 35-percent reduction in channel capacity resulted in reduction of the system weight from 35 to 23 pounds. Power requirements were reduced from 15 to 11 watts, and the overall package length was reduced from 31.7 to 20.6 inches.

Other changes that occurred during this redesign included a change from pigtail to face-mounted connectors, elimination of an electromechanical elapsed-time indicator, provision for external power for the ground-support-equipment (GSE) buffer-signal outputs, and elimination of a redundant power supply for the system-timing circuits.

The VHF transceiver. - The most significant design features of the LM VHF transceiver were its small size and low power consumption. Two design techniques were used to incorporate the design requirements and still have a lightweight, efficient unit. One of these was to provide audio-input clipping of approximately 40 decibels. This was changed to 20 decibels to provide maximum signal audio power without loss of intelligibility. Secondly, the carrier was modulated by keying the transmitter on and off at the audio rate, a technique which allowed the use of transistors (with an efficiency of approximately 85 percent) in the RF power output stages. Heavy modulation and power-amplifier transformers were not required. With this modulation technique, the transmitter would be off during pauses between words. Therefore, a noise-suppression oscillator (operating above the audio range at 30 kilohertz) was added to keep the transmitter on during word pauses; this feature stabilized the automatic gain control (AGC) in the CSM receiver. The resulting system provided the efficiency required and was compatible with standard AM equipment.

The SPA. - Originally, the SPA was based on the design of similar equipment in the CSM. The SPA consisted of two units: a PMP and an audio center. In mid-1964, additional communications-system requirements resulted in the addition of the

following: a VHF-receive channel and two additional VHF-transmit channels in the audio center, band-pass filters to separate EV-crewman voice and data, four individual volume controls (one for each received signal in the audio center), a transmit/receive control, and voice-operated-keying (VOX) circuits for the additional VHF equipment. In December 1964, the hardwire intercom between the LM and the CSM was removed, and the load impedances of the PM mixing and emergency-key circuits were revised to make the circuits compatible with the S-band equipment.

At the end of 1964, the SPA packaging was changed when the functional ERA concept began, and both the PMP and the audio center functions were combined into a single assembly constructed from five major subassemblies. Other changes that resulted from breadboard testing at the second-tier vendor's facility and from updating of interface requirements were the substitution of a dc-to-dc converter for three smaller individual power supplies, the addition of EMI filters, the deletion of the TV signal, the deletion of one VHF-transmit channel, a change in the PM- and the FM-output levels, the potting of a filter to prevent shorting, the addition of 6-dB/octave preemphasis to the EV-data channel, and the elimination of potential single-point failures.

During qualification tests, the SPA case developed a crack during vibration. The problem was resolved with wraparound braces riveted to each corner of the box. Other failures that occurred during the initial qualification test and the corrective actions that were taken were as follows.

1. Distortion in the 14.5-kilohertz-baseband PM output required the addition of isolation in the voice-biomedical amplifier-mixer.
2. The headset-amplifier output for both channels of the audio center was out of tolerance and required a gain change.
3. The 1.250-megahertz subcarrier was out of tolerance during temperature tests and required the addition of temperature compensation.
4. The sidetone output was out of tolerance and required a resistor change.

Other qualification-test failures were related primarily to manufacturing or testing errors and component quality-control problems that were resolved for the subsequent production units.

TEST PROGRAM

The Apollo test program was extensive. The objectives were to corroborate and demonstrate all design and reliability parameters in accordance with the specified operational requirements. The objectives were accomplished by using the results of the many test phases from component tests through vendor, contractor, and launch-facility tests to the flight tests. The various test methods and test programs that were used in the development of the system are described in the following paragraphs.

Test Philosophy and System Tests

The LM testing program involved testing from the level of a component part to testing of the entire vehicle. The tests were accomplished in many phases and included the following basic types.

1. Developmental
2. Qualification
3. Acceptance
4. Ground vehicle
5. System compatibility
6. Flight vehicle

The testing was extensive at all levels. The program initially involved breadboard models and breadboard tests at the second-tier vendors' facilities followed by the building and supplying of experimental models that were integrated into the two ERA's at the subcontractor's facilities. Service test models were produced for environmental testing at the second-tier vendors' facilities. Then, the models were shipped to the subcontractor for integration and further environmental testing. The environmental test was the design-verification test (DVT). Whereas other systems retained DVT at the second-tier vendors' facilities, in communications, DVT related to the subcontractor system-integration tests (eventually dropped after prototype integration). The DFT's (which, for communications, meant testing at the second-tier vendor's facility) were retained with the rigor of the DVT program. In this context, DFT for communications is synonymous with DVT on other subsystem test programs.

Prototype models were developed for the reliability-assurance tests (RAT's) that were to be followed by a twofold qualification-test program. The RAT program was designed to determine the probability of failure, to provide information for failure-effects analysis, and to provide backup information for reliability assessment. Eventually, the program was found to be too extensive. Also, the program became nonapplicable because the subcontractor no longer integrated flight equipment.

In the latter part of 1964, program changes that generally reflected the final test effort were implemented. In addition to the overall program change from the two ERA's to the functional ERA concept, many tests (such as sand and dust, salt-fog, fungus, and explosion tests) were largely eliminated. Breadboard tests and developmental tests were consolidated into the DFT at the second-tier vendors' facilities; therefore, no breadboard or experimental models were delivered to the subcontractor. The DFT program then included, in the following order, an operational, a nonoperational vibration, an operational, an operational vibration, a thermal vacuum, a shock, an operational, an EMI, a voltage overstress, a thermal vacuum overstress, and a vibration overstress test.

Continuing program changes resulted in further test-program modification. The subcontractor test-integration effort was defined; and, eventually, preproduction unit 1

(PP-1) and PP-2 tests were reduced in scope and then deleted because the hardware did not reflect the functional ERA concept. The PP-4 and PP-6 integration tests were retained, but they were reduced in scope. The integration tests were terminated before the production-equipment tests. Even so, the preproduction integration tests provided valuable system-performance information. The analyses of the integration effort were useful, especially the interface analysis. The ambient operational tests of the EMI testing were valuable because the results of these tests were used for system analyses. In retrospect, the need for tests other than thermal or thermal vacuum tests on a system basis is questionable when the results derived are compared with cost.

In early 1968, CCA-726 imposed a high-level-vibration test during ERA acceptance to screen workmanship defects. A reevaluation was made on each ERA to determine whether the equipment was qualified for the new acceptance-test levels. Although the original vibration levels were within the new requirements, the vibration frequencies (except for the PCMTEA) did not conform to the new test levels in all cases. This meant that these ERA's would have to be requalified. However, the many design changes that had occurred since the original qualification had resulted in additional qualification-testing requirements for each ERA (with the exception of the DUA, for which requirements were established after CCA-726 went into effect). Thus, the CCA-726 requirements and the design changes were qualified in a single delta-qualification program. A diagram of the qualification-test history just discussed is shown in figure 16.

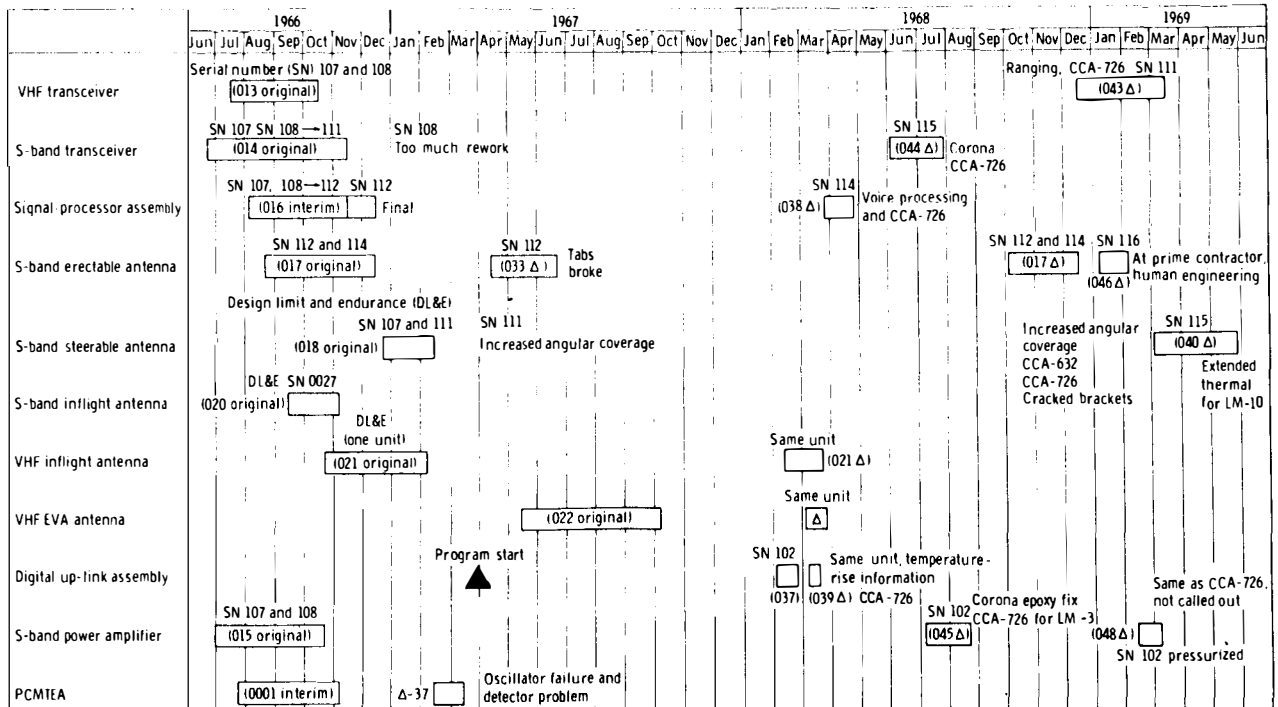

Numbers in bars are the equipment control numbers (certification test requirement)
 Numbers above bars are the serial numbers of the units tested

Figure 16. - Communications-system qualification history.

The tests performed after delivery of the ERA's to the prime contractor were as follows.

1. Preinstallation tests were used to check incoming equipment before installation on the spacecraft to ensure proper operation after shipment.
2. Vehicle system tests were used to demonstrate the integrity of the equipment after installation.
3. Vehicle integration tests were used to determine the physical, functional, and operational compatibility of all systems.
4. The KSC tests ensured system and vehicle flight readiness.

Assemblies and components procured or developed by the prime contractor, such as coaxial cables and antennas, were qualified as assemblies and integrated into the spacecraft at the prime-contractor facility. The Government-furnished equipment, such as the TV camera and the PLSS radio, were qualified at the vendor's facility and integrated into the spacecraft at KSC.

The following special tests were conducted as part of the Apollo test program for communications.

1. Extensive RF-compatibility tests, which included operational hardware, were performed at MSC among the LM, MSFN, CSM, and EV equipment.
2. RF-compatibility tests among the LM, MSFN, CSM, and EV equipment were performed on LM-4 at prime-contractor facilities using simulated MSFN, CSM, and EV equipment.
3. Special system tests were performed at MSC. The tests included compatibility tests between ERA's and crew equipment, noise-level measurements, and compatibility tests between proposed hardware changes and the existing system.
4. Antenna tests — which included determination of antenna characteristics, patterns, and operation, and investigation of potential problems — were performed at MSC.
5. Flyover tests to evaluate communications-system/MSFN compatibility were performed at the NASA Goddard Space Flight Center.

Ground-Vehicle Tests

The LM test article 1 (LTA-1). - The LTA-1 was an electronic-equipment-integration test vehicle. In addition to a preproduction communications system (without a steerable antenna), LTA-1 contained the electrical and electronics packages of the other systems. Electromagnetic-interference tests performed on the LTA-1 disclosed no resultant interference on the communications ERA's. The LTA-1 also served as a training vehicle for the test and checkout personnel and was used to evaluate procedures that were used on subsequent ground and flight vehicles.

The LM test article 3 (LTA-3). - The LTA-3 contained mass representations of the communications-system ERA's. The mass representations were instrumented so that ERA vibration levels could be measured when the vehicle was subjected to launch- and boost-vibration inputs. The vibration levels were used to determine the vibration-test levels for acceptance tests and qualification tests of the ERA's.

The LM test article 8 (LTA-8). - The LTA-8 was the thermal vacuum test vehicle. Following a complete factory test program at the prime-contractor facility, the vehicle was delivered to MSC for the thermal vacuum test program that was performed in chamber B of the Space Environment Simulation Laboratory. The LTA-8 contained a complete communications system.

The factory testing of LTA-8 included the following operational checkout procedures (OCP's): OCP-38026 and OCP-38027, VHF and S-band voltage/standing-wave ratio and insertion-loss measurements; OCP-38036, S-band steerable-antenna verification; OCP-38037, communications-system functional verification; OCP-61015, final engineering acceptance test/electromagnetic-compatibility systems verification, plugs in; and OCP-61018, final engineering acceptance test/electromagnetic-compatibility systems verification, plugs out.

Several difficulties were encountered with LTA-8, and OCP-61018 was performed twice before the system was accepted and shipped to MSC. None of the problems that necessitated the retest were attributed to the communications system.

The MSC testing included OCP-B-38029, OCP-B-90000, OCP-B-90001, and OCP-B-90002. The communications-system verification test (OCP-B-38029) was performed satisfactorily, and the communications-link verifications (on the VHF and S-band) were within the prescribed tolerances. The following two major problem areas delayed test completion.

1. The LM steerable-antenna slew test delayed completion of OCP-B-38029 for 1 week because of erratic operation of the steerable antenna. The trouble was isolated in the panel 12 pitch-and-yaw control knobs, which were improperly aligned on the control shaft.

2. More than 110 procedural deviations occurred during the test. Most of the deviations were attributed to incorrect switching sequences.

Manned-rating test OCP-B-90000 revealed the only major communications problems encountered during the manned-rating tests: the S-band down link could not be acquired at the communications test station when the test chamber was at a pressure of less than 2×10^{-3} psia. Because of the fatigued condition of the astronauts, no further communications tests were conducted at that pressure. However, the prime contractor reran the manned-rating tests at ambient conditions and could not re-create this problem. Subsequent investigation indicated that corona caused the anomaly. However, the transducer monitors inside the S-band power amplifiers and transceivers gave no indication of a corona problem. The S-band power amplifier was replaced, and the problem did not recur in subsequent vacuum tests.

The thermal vacuum tests (OCP-B-90001 and OCP-B-90002) revealed only a steerable-antenna slew problem that appeared when the steerable antenna was subjected

to a brief manual-slew test (five positions in pitch and yaw). The crew reported that the antenna did not respond properly to the pitch-and-yaw control knobs. After ice was found throughout the chamber and on the antenna, the prime contractor reported that the anomaly was caused by gimbal freezeups. However, failure investigation at the second-tier vendor facilities revealed that an unsoldered transistor caused the problem. Two other thermal vacuum tests were run on LTA-8; however, the communications system was used only as a heat load.

Lunar module 2. - System tests and integrated tests were conducted on LM-2, which was used as backup for the Apollo 5/LM-1 mission, at the prime contractor facilities. The factory tests were the same as those previously listed for LTA-8. After acceptance at the phase III customer-acceptance readiness review and the successful launch of Apollo 5, LM-2 was shipped to Houston for ground testing.

In late 1968, the decision was made to use LM-2 as a lunar-landing drop-test vehicle. The two major objectives of the simulated-lunar-landing drop test were to demonstrate that the operational systems functioned successfully during a simulated lunar landing and to demonstrate that the systems required for a launch from the lunar surface and rendezvous with the CSM could operate successfully after a simulated lunar landing. The communications-system testing verified the ability of the system to maintain phase lock of the S-band system using the steerable antenna throughout lunar-landing impact. No equipment problems were encountered.

Flight-Vehicle Tests

The previously described factory test program used on the LTA vehicles was used for LM-1, LM-3, and LM-4. During system functional verification, difficulties were experienced because of interference caused by simultaneous testing of other systems. Conflicts were encountered continually in cooling requirements and PCM-bit-rate requirements. The conflicts contributed to the test-flow changes that were initiated for LM-5. The insertion losses and voltage/standing-wave ratios for LM-5 were measured during vehicle construction. The system verification was performed in OCP-62000-COMM (the communications section of the combined system preacceptance test for the vehicle). This verification and the test procedures for all systems were performed with a control procedure that eliminated many system conflicts.

During the testing of these vehicles, the greatest concerns were the availability of flight hardware for testing and the condition of the communications test station (CTS). The vehicles were tested during a period when many modifications were taking place in the ERA's (for example, pressurization of the S-band transceiver and power amplifier, voice-improvement changes in the SPA, addition of VHF ranging, and steerable-antenna modifications). As a result, many OCP's and final engineering acceptance tests were performed with interim equipment; the installation and checkout of the flight equipment were done at KSC. Many test discrepancies were attributed to the CTS. The number of discrepancies was lowered by the improved calibration procedure, which was partially employed for LM-5, and by the addition of a third CTS (shipped from MSC after the LTA-8 tests), which reduced the loading of the other two units.

Lunar module 1. - The testing methods used on LM-1 at KSC were derived basically from the prime-contractor ground-operations requirements plan (GORP) and consisted

of tests that were very similar to those performed at the prime-contractor facility. The test procedures were modified to include interface and compatibility testing with the Merritt Island launch area ground station. The LM-1 also served as the training vehicle for KSC test personnel.

Lunar module 3. - The GORP was eliminated for LM-3 testing, and an expanded test and checkout requirements document (TCRD) was developed from the prime-contractor TCRD; the expanded TCRD included interface testing with the MSFN, the CSM, and the PLSS. The test-specification and criteria document was used in conjunction with the TCRD to establish the test requirements in greater detail and to establish the specifications and tolerances of the test measurements. The following major test procedures and problems were associated with LM-3.

1. TCP-KL-0010. Resistors used to form an EMI filter in the ground-return line of the VHF transceivers were found defective as a result of a GSE-interface problem at the subcontractor's facility. The unit was returned to the subcontractor for removal of the filter, which was added to the vehicle wiring.

2. TCP-KL-0013. Communications problems that arose during the altitude-chamber test were not attributed to the spacecraft system.

3. TCP-KL-0033. The combined-systems test at the Vehicle Assembly Building was completed with no significant anomalies encountered in the communications equipment. Frequency clearance was restricted by the Apollo 8 (CSM-103) simulated-mission-countdown-demonstration test. The LM-3 communications system passed all test sequences. During the up-link/down-link combinations-mode checks, S-band and VHF voice intelligibility was satisfactory in all cases.

4. TCP-KL-0005. During the flight-readiness test, both the VHF and the S-band systems performed satisfactorily. The reception of PLSS voice and data relayed through the LM and the MSFN station at KSC was extremely good at the Mission Control Center, Houston, Texas. As expected, baseband voice caused PCM bit errors that affected both high- and low-bit-rate telemetry.

5. TCP-KL-0007. The communication sequences of the countdown-demonstration test were conducted successfully with no discrepancy reports against the LM communications system.

Lunar module 4. - The tests for LM-4 were modified to reduce the number of tests performed before the altitude-chamber test. The following test procedures and problems were associated with LM-4.

1. TCP-KL-0039. The communication sequences of the system functional test were conducted successfully. A special test procedure (number 86), which provided a complete retest of the VHF transceiver after ranging modification, was conducted successfully. The system functional test was not intended to simulate the LM-4 mission. For instance, strong up-link and down-link signal levels were used, and only one LM down-link mode was verified. However, the test was designed to verify that all systems were in the proper operational condition and to detect any degradation caused by vehicle shipment from the prime contractor and subsequent installation at KSC. The LM-4 communications equipment operated satisfactorily.

2. TCP-KL-0013. The altitude-chamber tests consisted of an unmanned run, a first manned run, and a second manned run. Simulated missions were conducted to determine vehicle safety and system capability in a high-altitude environment. During the first manned run, the test was aborted because of problems in the environmental-control system. However, the communications system performed normally during the test.

3. TCP-KL-0033. The communications sequences of the combined-systems test were conducted successfully. No discrepancies were found in the LM communications system.

Lunar module 5. - The tests for LM-5 followed the same general guidelines as those for LM-4. However, tests were performed on the erectable antenna, which was not used on LM-4. The following major test procedures and problems were associated with LM-5.

1. TCP-KL-0039. Interim discrepancy report 12 was prepared when the unlocked AGC voltage was measured at 0.53 volt. (The test limit is a maximum of 0.50 volt.) The secondary-transceiver unlocked AGC voltage was measured at 0.61 volt. Later, the information in the interim discrepancy report was transferred to vehicle discrepancy report 123, which was prepared against the transceiver. Tests on both primary and secondary transceivers indicated normal AGC curves in the phase-locked condition. After additional tests on the signal-to-noise ratio and the antenna AGC showed that the phase-locked primary transceiver was normal, the discrepancy report was closed. No interim discrepancy reports were prepared during VHF test sequences.

2. TCP-KL-0013. The unmanned test was completed without difficulties. The first manned test with the backup crew was aborted because of problems with the water boiler. However, the LM pilot had noticed audio feedthrough in the intercom tests before cessation of the test. The first manned test was rerun, and the commander commented that minor feedthrough during the intercom-system test presented no difficulties. During the second manned run (with the prime crew), minor feedthrough again presented no difficulties to the crew. The audio feedthrough was caused by SPA diodes that did not completely inhibit the audio signals. The problem was corrected on all units except the unit on LM-5.

The second manned run was repeated because of the water-boiler problem encountered in the first run. Interim discrepancy report 39 was prepared when the LM pilot's umbilical push-to-talk switch did not function normally. The attitude-control push-to-talk switch then was used, and its operation was normal. Although the umbilical push-to-talk switch problem could not be repeated during tests made after repressurization, the umbilical subsequently was replaced.

3. TCP-KL-0033 and TCP-KL-1222. The combined-systems and CSM/LM interface tests were combined because of scheduling difficulties imposed by additional work required on the water-glycol system and the CSM schedule for TCP-KL-1222. TCP-KL-0033 proceeded until the communications-system checkout was adequate to support TCP-KL-1222; then, TCP-KL-1222 was performed. After completion of TCP-KL-1222, TCP-KL-0033 was completed.

During TCP-KL-1222, interim discrepancy report 3 was prepared because voice transmission interfered with VHF ranging acquisition. The SPA feedthrough diodes had permitted voice to enter the VHF ranging channel.

4. TCP-KL-0005. The VHF and S-band equipment was tested during communications turn-on in the flight-readiness test. The PLSS was tested by verifying communications between EVCS-1 and EVCS-2 and by demonstrating dual EVCS communications to the LM. After the PLSS tests, all communication points (LM, CSM, EVCS-1, EVCS-2, and MSFN) were actuated, and successful transmissions were performed on all channels. Television reception was tested with down-link simulation of the received signal strength. The last test sequence was a VHF ranging test that simulated different LM to CSM distances. The mission-simulation portion of TCP-KL-0005 was accomplished with good results.

5. TCP-KL-0007. Three problems were encountered during the communications sequences of the countdown-demonstration test. One problem involved the commander's umbilical cable, and the other two problems involved the S-band steerable antenna. During the calibration of the antenna control knobs, difficulties developed with the setscrews; the setscrews were replaced, and the knobs were calibrated. Also, following arming of the antenna, the access door to the electronics package was damaged. The electronics package subsequently was repaired and reinstalled.

SYSTEM RELIABILITY AND PERFORMANCE

The basic approach toward the attainment of the reliability goals was to optimize the basic design by determining possible failure modes or sources in the design and by correcting or eliminating potential sources of failure. The major considerations included planning and implementing a comprehensive reliability program plan; reliability training and indoctrination; design reviews; parts selection; application and control; reliability apportionment and estimates; configuration analyses; failure-mode-prediction analyses; circuit- and failure-effect analyses; maintainability analyses; and failure reporting and analyses.

The quality program was guided by NASA Quality Assurance Publication NPC 200-2 entitled "Quality Program Provisions for Space System Contractors," which required that material, component, and part suppliers follow the guidelines of NPC 200-3 entitled "Inspection System Provisions for Suppliers of Space Materials, Parts, Components, and Services." The quality-assurance provisions of NPC 200-2 were demanding and detailed. The provisions emphasized an organized approach to quality assurance through all phases of contract performance, including preliminary-engineering design, development, fabrication, processing, assembly, inspection, test, checkout, packaging, shipping, storage, maintenance, field use, flight preparations, flight operations, and flight analysis. The quality-program system provided for prompt detection of deficiencies, system incompatibilities, marginal quality, and trends or conditions that could result in unsatisfactory quality. Considerable emphasis was placed on planning, determination of quality characteristics, documentation, traceability, material purchase, fabrication control, and corrective action.

As a general indication of performance during the development of the communications system, the number of failures for each ERA is shown in table IV. Failures decreased from a maximum during acceptance tests to a minimum during vehicle tests. The value of the reliability and quality assurance has been demonstrated by the absence of any equipment failures during the operational flights.

TABLE IV. - FAILURE SUMMARY FOR MAJOR SECTIONS OF THE
LM COMMUNICATIONS SYSTEM

Section	Number of test failures				
	Qualification	Development verification	Acceptance	Preinstallation	Vehicle
S-band transceiver	15	0	74	5	2
S-band power amplifier	17	1	186	14	2
S-band steerable antenna	11	0	112	0	7
Signal-processor assembly	36	13	127	2	2
VHF transceiver	25	4	68	5	3
Digital up-link assembly	0	0	10	0	1
PCMTEA	92	10	53	0	5

SIGNIFICANT MODIFICATIONS AND PROBLEMS

Modifications and problems that occurred in the LM communications system after the original qualification tests are discussed in this section.

Steerable Antenna

Antenna coverage, CCA-726, and structural cracks. - A change in program requirements to increase the steerable-antenna coverage resulted in a major redesign. The mounting configuration on the LM was modified, the electronics box was rotated,

the gimbal limits in the yaw axis were increased, and the servosystem-loop gain was increased. These design changes necessitated requalification of the antenna. Shortly before the requalification program was scheduled to begin, CCA-726 was issued, and the vibration-test levels were increased. During requalification, structural failures occurred in the antenna-electronics-package mounting. The cracks, which were concealed by thermal paint, were not discovered until several antennas had been delivered to the prime contractor. As a result of the failures, new housings were designed for antennas in production, and antennas that had been installed were retrofitted on the vehicle with fiber-glass and epoxy braces.

"Mule" failures. - During requalification tests, a failure occurred in one of the antenna "mules" (a two-layered printed-circuit board). This mule was replaced; however, a second mule failure occurred. Mule failures occurred on other antennas at both the manufacturer and prime-contractor facilities. Investigation revealed that the failures resulted from thermal or structural stresses (or both) occurring between solder joints and potting material. Electronics packages were built with improved techniques for assembling, soldering, and potting; improved inspection; and improved handling procedures. Mission-simulation tests were performed to verify that the new units were flightworthy.

Intermodulation products. - During testing of an early production antenna at MSC, intermodulation products on the S-band up-link signal, which was used to position the steerable antenna, caused severe tracking errors that could have made tracking impossible under normal mission conditions. Extensive tests at MSC revealed that the intermodulation products could be reduced to an acceptable level by reducing the modulation indices on certain up-link modes without seriously altering the up-link quality. The modulation indices were changed at all ground stations before the first steerable antenna was flown.

Integrated circuits. - A failure that occurred in the steerable antenna during second-tier vendor testing was attributed to a μ A702 integrated circuit. During the failure analysis, an internal aluminum leadwire that had opened because of corrosion was located. Further tests and analyses indicated that the problem was limited to the integrated circuits in glass flatpacks with aluminum internal leads (μ A702 and μ A710). The following two failure mechanisms were occurring.

1. Aqueous corrosion was caused by contaminant on the wires and moisture that either was entering the package through a leak or was being sealed within the package. Further analysis indicated that the sealing of moisture within the package was improbable.

2. Glass-splattering that occurred when the glass-to-metal seal was made accounted for the contamination seen in some of the integrated circuits. This reaction between the glass and the aluminum inside the integrated circuit occurred with no additional outside factors. These failures began with integrated circuits bonded after March 22, 1967, and continued through final manufacture of that type of circuit in 1969.

Because of the extensive use of the μ A702 integrated circuit throughout the LM, an ad hoc team was established to make a comprehensive review of pertinent data. This team made the following determinations.

1. Twelve corrosion-induced failures occurred in the vendor's stock of 2246 integrated circuits, which had an average shelf life of 0.8 year. The failure rate was 0.75 failure/million hours.

2. Of the 421 integrated circuits (installed in the LM), which had an average age of 1.6 years, no corrosion-induced failures occurred. One failure was assumed, and the resultant failure rate was 0.17 failure/million hours. The installed integrated circuits had a lower failure rate because they were protected from handling and were conformal coated or potted; thus, a moisture barrier was provided. The circuits at the vendor had been subjected to environments designed to accelerate the failure rate and had received additional handling during tests.

Based on this information, the failure rate for assembled hardware was designated as $\lambda = 0.17$ failure/million hours. This failure rate was acceptable for parts of this type.

These data were presented to the MSC Configuration Control Board (CCB) on December 12, 1969, and the assembled hardware was declared flightworthy.

The ad hoc team assessed the possibility of increasing the reliability of unassembled spacecraft hardware (for example, the S-band steerable antenna and other vendor spare parts). The team concluded that a screening process could be developed for the 3H glass flatpacks. The screening process consisted of environmental exposures (thermal cycling and mechanical shock) and a leak test after lead processing. The possibility of using a different integrated circuit also was investigated. This investigation led to consideration of the 3F integrated circuit. The same internal parts were used, but the circuit was encased in a ceramic package that had an inherently better hermetic seal. The 3H integrated circuits were retained on the basis of good field experience, confidence in the screening processes, and lack of comparable experience with the 3F device. However, the 3F integrated circuit was developed as a backup. For increased reliability, unassembled hardware was built with screened 3H integrated circuits.

Wire wrap-ups. - Wire wrap-ups were used instead of rotary joints to transfer the control- and power-circuit inputs and outputs across the antenna axes of rotation. During early production, a number of electrical short circuits developed in the wrap-ups because of minute metal filings embedded in the surface of the wrap-ups. Stringent quality control and inspection during the fabrication and assembly processes eliminated the problem. In 1968, a second wrap-up problem occurred during acceptance testing of flight antennas because of procedures for gimbal assembly that allowed incorrect installation of the wrap-ups. The antennas at the prime contractor and KSC were cycle tested in an attempt to induce failures in antennas with incorrectly installed wrap-ups; one antenna was found to have this problem. The assembly procedure was corrected for the remainder of the antennas in production.

Stow position. - An error during production resulted in two antennas with an incorrect stow position in the Y-axis. However, because of schedule problems, the antennas were used with the incorrect stow position (based on the satisfactory results of a thermal analysis).

Heat shield. - The antenna vendor had production delays because of low heat-shield yield during early production. The delays resulted from the tight tolerances required and the learning process at the heat-shield vendor. Also, a design change was required because of heat-shield binding on the antenna support boom when the antenna was installed on the vehicle. The problem was solved by increasing the heat-shield diameter.

Circuit breaker and loss of up link. - As a result of the increased-coverage design change, current limiting was removed from the drive motors to provide increased capability. During vehicle testing on LM-4, the antenna tracked an RF signal into the antenna gimbal stops. The dc circuit breaker opened when the condition occurred because the motors drew maximum current in an attempt to continue tracking. Also, if up-link lock was lost, the antenna slewed to the stops. (See the section entitled "S-Band Transceiver" for a discussion of this problem.) The breaker did not open; but current, which could overheat the motors, was drawn. These problems were corrected with operational procedure changes; if the antenna tracked into the stops and opened the breaker or if up-link lock was lost and the antenna slewed into the stops, the normal signal was reacquired or the antenna was turned off.

Manual signal acquisition. - An analysis was performed on the tolerance buildup that would affect manual acquisition. Several factors had large tolerances that could prevent manual signal acquisition if the tolerances added unfavorably. The knobs located on panel 12 in the LM were calibrated to reduce the tolerances. The calibration was performed with the antenna stowed and the drive motors nulled (which was verified audibly by the use of a stethoscope). The knobs then were set to the stowed positions indicated on the panel. During calibration, the knobs had a tendency to slip on the synchroshafts. Each knob was modified to use two setscrews and helicoil inserts that provided added strength on the threaded surfaces.

Antenna blockage. - Because of the difficulties encountered on LM-5 in establishing automatic tracking, an investigation of the RF blockage diagrams used for preflight predictions was conducted. The results of the investigation indicated that, following the increased-coverage design change, a blockage diagram in use did not show several areas where blockage occurred. The diagram was revised in all affected documents.

Heater checkout. - The antenna required cooling below the thermostat-trip level (-40° F) to turn on the internal heaters. During checkout of the antenna on the vehicle, proper operation of the electronics-box heaters could not be verified. The integrity of the copper path was verified by applying voltage to the heater inputs. For LM-5 and subsequent vehicles, the internal temperature of the electronics box was telemetered to the ground for real-time monitoring.

S-Band Power Amplifier

The S-band power amplifier had many corona problems. Seventeen corona failures of the power amplifiers occurred between July 15 and September 12, 1967. There

were four types of corona: ac corona, which could be recognized by a visible glow, was experienced on all units tested; RF corona, which was indicated by a sharp loss of output power with no change in input current; dc arc in the high-voltage module near the power connector, which was indicated by a loss of output power and probable loss of input current; and dc arc in the potted high-voltage power supply, which was indicated by a decrease in output power and input current. All the corona types occurred at critical pressure, but the ac and RF coronas were self-extinguishing. The other corona types in the high-voltage module were destructive.

The ac corona resulted from an ac field outside the potted high-voltage module. To bring a ground plane against the potting, a grounded 2-mil-thick nickel strip was welded against the potted module, and an epoxy overcoat was applied. This modification prevented the ac field from penetrating into the airspace outside the module.

To eliminate the RF corona that occurred in the output isolator, the distance between two vanes within the isolator was widened. The unit subsequently was tested with 30 watts of input power (normal is approximately 1 watt) and operated properly.

One of the dc arcs, which was caused by current leakage from cracks in the potting, was isolated to the high-voltage leads at the connector. The problem was corrected by removing the potting, applying a primer, and repotting. The primer helped the plotting adhere to the mold and solder joint.

The other dc arc in the high-voltage power supply resulted from cracks and voids in the potting that allowed arcing to ground. The outside walls of the module were coated with epoxy, which was intended to prevent air molecule transfer.

Because of the short time allowed for the corrective actions that were taken, discrete engineering analyses to determine the actual cause and location of the corona were not possible. For example, the many problems that developed during testing of the epoxy coat resulted in an extensive redesign of the heat sink for the high-voltage power supply and in corona screening of all components. In September 1968, a post-qualification review was performed, and corona anomalies were noted in the test results. The failures were a result of corona breakdown in the amplatron-tube potting.

On November 18, 1968, the CCB requested special corona tests on amplatron tubes and S-band power amplifiers. The tests analyzed corona conditions that resulted from possible potting voids in the amplatron tubes. In January 1969, as a result of the tests, the CCB authorized pressurization of the power amplifier as the most reliable method of eliminating corona.

Two measurement points in the power amplifier, the forward-power output and the reflected-power output, were never accurate; and the forward-power output was used only to indicate high power or low power. Because of space restrictions in the pressurized case, the measurement points were deleted.

S-Band Transceiver

Corona and pressurization. - In September and October 1967, four failures occurred in the S-band transceiver because of corona in the RF multiplier chain. The

prime contractor recommended that the multiplier chain be foamed and that the circuits be sealed with combinations of epoxy and foam and an overcoating of 0.004-inch aluminum foil. Long-term thermal vacuum tests were performed to evaluate effects of temperature, vacuum, and humidity on the sealing materials. The tests provided information on the leak rate and time-to-failure for this type of seal.

The delta-qualification test of the seal began in May 1968. On May 18 and 19, 1968, a corona failure occurred in both transceiver channels. On May 29, 1968, this problem was presented to management, and it was decided that the S-band transceiver case would be pressurized for LM-3 and subsequent lunar modules.

Noisy AGC tracking signal. - During a steerable-antenna test on LM-4 when up-link lock was lost, the steerable antenna drove into the gimbal stops. This problem was caused by the AGC circuit in the transceiver going to full gain and amplifying noise that was routed to the steerable-antenna tracking-circuit input. To correct the problem, a level detector that would disable the AGC tracking signals at loss of signal was needed. However, because of cost and schedule impacts, the modification was not made; and the existing system was used after introducing a procedural change that prevented overheating of the servodrive electronics.

Telemetry-point noise. - During the flight of LM-1, the telemetered measurement of transmitter output power varied considerably. The cause of the apparent power variation was noise at the telemetry measurement point. On subsequent missions, a filter added to the measurement point eliminated the problem.

Control of PM/FM. - It was discovered during system testing that the transceiver reverted to the PM mode from the FM mode when power to the control circuits was interrupted. The assembly remained in the PM mode until the modulate switch was recycled through "PM" back to "FM." Because the automatic restoration of FM was desirable but not a mandatory requirement, no modifications were made.

The VHF Transceiver

The VHF ranging. - The most significant modification to the VHF transceiver was the addition of VHF ranging capability, a new requirement that established a backup to the rendezvous radar. The ranging modification increased power-supply ripple to the receiver and affected sensitivity. An additional filter capacitor was added to solve the problem.

Corona. - When it was determined that the aft equipment bay in the LM would be at a partial pressure during flight, a corona test at this pressure was added to the acceptance test. Failures, in the form of low RF in the multiplier section of the transmitter, were experienced on some units. A Teflon barrier was added between critical components to resolve the problem.

Voice-clipping level. - Compatibility testing indicated that the clipping level in the VHF modulator was too high. The LM cabin noise was higher than anticipated, and the clipping reduced the signal-to-noise ratio to an unusable level. The new clipping level of 20 decibels was selected as a compromise between noise reduction and maximum range capability.

The EMI filter. - A GSE-interface problem caused an EMI filter in the receiver power return to burn out. In the first analysis, the filter was considered unnecessary for the vehicle frequencies present, and the filter was removed. However, later vehicle testing indicated that the filter was necessary. Because of VHF delivery schedules and the cost involved, the filter was replaced in the circuit as a box outside the transceiver ERA.

Digital Up-Link Assembly

Up-link voice. - Shortly after the DUA program began in March 1967, the DUA was modified to provide a redundant up-link-voice path. This change eliminated the single-point failure for up-link voice in the SPA 30-kHz discriminator. The modification included an audio amplifier in the DUA and the required panel controls. The DUA voice output was fed directly into the crewmen's headsets; however, the audio level was not adequate. Therefore, the audio from the DUA was routed to the commander's microphone input and was amplified by the commander's audio center to a usable level.

Integrated circuits. - A reliability notice was issued to all users of a specific type of integrated circuit to inform them that certain lots of this type circuit had been found defective. Upon investigation, it was discovered that integrated circuits from these suspect lots had been used in the DUA. New integrated circuits were procured, and the suspect units were replaced.

Power-off pulse. - During testing, it was discovered that transient pulses appeared on the output lines when the DUA power was turned off. The pulses caused an "up-link-too-fast" PCM indication and fed erroneous information into the LGC. A procedural change that cleared the LGC when the DUA was turned on (either by up-link commands or from the DSKY in the LM) solved the problem.

Erectable Antenna

Lifting bar. - The original erectable-antenna design for lifting the antenna package onto its tripod contained provisions that were based on a crewman-stoop-reach capability (hand above surface) of 18 inches. As backpack size and weight increased, the safe stoop-reach capability was revised. Therefore, a rigid bar was placed on the erectable-antenna package that could accommodate a stoop-reach range of 0 to 36 inches.

Sharp rib tips. - The ribs of the antenna were made of thin (0.010 inch) aluminum channel. The cross section of the rib tip was rectangular, and the thin wall material made the edges sharp. The resulting danger to a crewman's suit and gloves was alleviated by coating the rib tip with urethane.

Gear train force. - During testing, it was discovered that the force required to change the gear train from azimuth to elevation was greater than a suited crewman could provide. The spring force was decreased.

Signal-Processor Assembly

Cable and connectors. - The wire bundle of the original 199-pin connector in the SPA was too stiff to withstand the flexing and handling that was necessary during the life of the unit. Therefore, the original connector was replaced by two 85-pin connectors. Most of the shielded wires were routed into one of the connectors, and the shields were terminated several inches from the connector. However, flexing between the shield-termination point and the connector caused the wires to break. The units were returned to the vendor for replacement of the entire pendant cable, which was then potted to form a rigid joint between the cable and the connector.

"Hot-mike" intercom. - Because of problems experienced with previous VOX communications systems, the crewmen requested that a positive hands-off intercom be provided. The SPA was changed to provide continuous "hot-mike" intercom with simultaneous push-to-talk capability for VHF and S-band transmissions.

S-band squelch. - During EV operations, the LM could relay received S-band communications to the crewmen on the lunar surface. If the up-link signal were lost, noise in the discriminator output would become very high. This noise would be relayed to the crew, and there was no way to turn it off without returning to the vehicle or turning off the PLSS receiver. Because neither of these methods was desirable, an S-band squelch was added to the SPA. This addition provided means for detecting loss of the 30-kilohertz subcarrier and cutting off the S-band audio path automatically by means of a diode switch.

Redundant power supply. - Original fail-safe requirements were based upon a short occurring at any power-supply output for 5 seconds. The requirements were changed to provide protection from a short of an indefinite period. Considerable redesign of the power supplies and control lines resulted. A single-point-failure study revealed that all amplifiers for received signals (S-band and VHF) were supplied power from one regulated power supply. To eliminate the single-point failure, a redundant power supply was added with the supply voltage coming from a completely different source.

Linear volume controls. - Because of a misunderstanding concerning the SPA/LM interface, the volume controls for the individual received signals were extremely nonlinear and responded more like switches than volume controls. The problem could be solved either by changing the controls on the vehicle to a linear type or by adding 16 resistors in the SPA to compensate for the nonlinearity. Because of cost and schedule, the SPA was changed.

Initiation of VOX AGC. - After compatibility testing at MSC, several problems with SPA design that were related to use in the LM were uncovered. During VOX operation of the microphone amplifier, the AGC did not begin to react to the signal until after the VOX actuation had occurred. As a result, the amplifier output appeared with maximum gain, which caused a pop at the beginning of each transmission. Design was changed so that AGC began simultaneously with VOX.

Gain reduction in hot-mike operations. - During hot-mike operation when no voice input existed, the microphone amplifier was at full gain and made the cabin noise very

objectionable. A design change provided for a 12-decibel gain reduction during this mode of operation. By pressing the push-to-talk switch, the gain was returned to normal.

The VHF-receive AGC amplifiers. - The VHF-receive AGC amplifiers caused considerable noise buildup during no-voice periods because the amplifiers operated at maximum gains (as in the hot-mike mode). The AGC amplifiers were replaced with linear amplifiers to alleviate this problem.

Miscellaneous changes. - Other changes included separation of the keying supply lines and addition of a redundant ground-return line to eliminate single-point failures; deletion of two transient-suppression diodes to eliminate an undesired feedthrough signal on the intercom bus; and a change to a more reliable GSE connector.

FLIGHTS

Apollo 5/LM-1

The LM-1 communications system included all S-band and signal-processing equipment that was necessary to verify MSFN communications compatibility with tracking and ranging data, RF up link (with simulated up voice and up data), and the transmission of PCM data.

The operational communications system performed normally throughout the mission. The S-band system was activated when the LM was separated from the S-IVB stage of the launch vehicle; reception of low-power primary-transceiver signals was verified. The secondary transceiver and the power amplifier were activated at 01:34:00 ground elapsed time (g. e. t.), and the high-power mode was employed throughout the remainder of the mission. The S-band down link consisted of the S-band carrier (2282.5 megahertz), PRN ranging, the turned-around up-link subcarriers (30 and 70 kilohertz), and S-band PCM telemetry. The S-band PCM telemetry was used during the entire mission in the high-bit-rate mode (51.2 kbps).

The S-band equipment also operated normally with respect to PRN ranging and tracking and up-link signals (with simulated up voice and up data). The capability of the turned-around up-voice channel was demonstrated by modulating the 30-kilohertz up-voice subcarrier with a 1-kilohertz tone at selected MSFN sites. The S-band up-data channel performance was demonstrated successfully when transmitting a 70-kilohertz unmodulated signal to the spacecraft transceiver from selected sites. Three stations were evaluated for S-band up-data-command capability.

No VHF equipment was flown on LM-1.

Apollo 9/LM-3

The LM-3 communications system performed normally during the Apollo 9 mission. In relation to the communications system, the purpose of the mission was to demonstrate VHF and S-band performance readiness for the Apollo 10 lunar flight.

The communications system included all S-band, VHF, and signal-processing equipment necessary (1) to transmit and receive voice, tracking data, and ranging data and (2) to transmit telemetry, TV, and emergency keying. Voice communications between the LM and the MSFN were provided by both the S-band and VHF transceivers, and voice communications between the LM and the CSM and EV crewman were provided by the VHF transceivers. Telemetry, ranging, and tracking data were transmitted to the MSFN by the S-band equipment.

Television signals of excellent quality were received during the two TV transmissions from the LM. Voice quality was good throughout the rendezvous phase of the mission. However, procedural errors or improper equipment configuration prevented communications between the Mission Control Center and the LM on several occasions.

Excellent voice transmissions were received from each of the crewmen during EVA. However, the crew did not receive Mission Control Center transmissions relayed through the Texas, Merritt Island, Bermuda, and Navy Vanguard stations because of improper equipment configurations at the network sites.

The MSFN relay, S-band backup-voice, keying, and steerable-antenna checkouts were deleted during LM activation. The VHF B and the secondary S-band backup-voice tests were accomplished successfully.

When the PLSS was first used, voice and EMU-data transmissions were poor and erratic. This difficulty was caused by the PLSS antenna, which had been left in the stowed position. Voice and data transmissions were good after the antenna was deployed.

The LM-pilot push-to-talk switches located on the PLSS umbilical and on the attitude-control assembly were inoperative at approximately 89 hours g. e. t. The LM pilot used the VOX mode for transmission during the remainder of the LM operations. The problem was attributed to a break in the common wire to the parallel push-to-talk switches.

Apollo 10/LM-4

The LM-4 communications-system performance was normal during the Apollo 10 mission. In relation to the communications system, the purpose of the mission was to demonstrate the system VHF and S-band performance at lunar distances and within 50 000 feet of the lunar surface. Also, the steerable antenna was to be used for the first time during flight. To test the system for the lunar-landing mission, the full-up-PM mode and the relay and backup modes were to be demonstrated. The following equipment and modes were tested and verified: high-power and low-power S-band transmission, high-bit-rate and low-bit-rate FM and PM, omnidirectional and steerable antennas, basic up-link and down-link modes, backup modes, and PRN ranging.

During lunar revolution 4, the relay tests were deleted because of lack of time. During revolution 10, additional communications tests (including tests of S-band and VHF-simplex and VHF-duplex modes) were made. For the rest of the mission, the "basic" communications configuration was used; during revolution 14, the MSFN S-band-relay mode was verified.

During the initial LM checkout, MSFN voice was received by the LM, but the MSFN could not receive voice from the LM because the "voice/off/down-voice backup" switch had been left in the off position. The switch was positioned to "down-voice backup," and the LM-voice reception was loud and clear at the MSFN.

During revolution 10 while a VHF communications checkout was being conducted (94:47 g. e. t.), the CSM did not receive VHF voice from the LM on duplex B or simplex A. Analysis indicated that the LM-pilot audio circuit breaker was open during the VHF-communications checkout. Thus, keying power to the VHF A transmitter was interrupted, and voice communication from the LM on channel A was impossible.

During revolution 12 with the communications system in the basic mode (using the S-band steerable antenna), S-band voice and data were lost at 99:08 g. e. t., and the S-band steerable antenna drove into the stops. After repositioning, the antenna reacquired good voice and data.

When the LM was 50 000 feet above the lunar surface, the S-band antenna would not track, and voice communications were intermittent. Crew debriefing revealed that the S-band antenna possibly could have been either in the manual-slew position or off. Because the S-band automatic-tracking mode of the steerable antenna had been demonstrated before and after descent, antenna failure was considered unlikely.

Apollo 11/LM-5

The communications system for LM-5 was basically the same as the system on LM-4 except that EV equipment and the S-band erectable antenna were added for lunar-surface operations and that feedthrough diodes were not removed from the SPA.

The performance of the communications system was normal. All prepreparation S-band and VHF tests were completed successfully. However, some difficulties were experienced with the steerable antenna during the descent to the lunar surface. Prior to a scheduled 180° roll maneuver, the signal strength dropped below the tracking level, and the antenna broke lock several times. After the maneuver was completed, new look angles were used, and the antenna acquired the up-link signal and tracked normally throughout landing. The problem was attributed to vehicle blockage and possible multi-path reflections from the lunar surface.

During EVA on the lunar surface, the LM relay provided good voice and EMU data. Occasional breakup of the LM pilot's voice occurred in the EVCS-relay mode. The probable cause was that the sensitivity of the VOX on the commander's audio center was set inadvertently at less than the maximum sensitivity specified. During EVA, the MSFN received an intermittent echo of the up-link transmissions, probably because of signal coupling between the headset and the microphone. Television transmission was good throughout EVA. The LM-voice and LM-data communications were normal during the lift-off and throughout the ascent.

RECOMMENDATIONS FOR FUTURE MANNED-SPACECRAFT PROGRAMS

As a result of approximately 7 years of experience in the development of communications systems for lunar-orbit and lunar-surface operations, the procedures and techniques used during this period can be evaluated for usefulness on future programs. Some procedures and techniques can and should be used; others should not. These recommendations are outlined in the following paragraphs.

Management Recommendations

The management of the system should be totally in one division. Support from other divisions with special technical capabilities and from outside contractors should be encouraged. The preliminary-design reviews and the critical-design reviews should be continued.

More emphasis should be placed on interface requirements. Engineering evaluations should be made to determine interface effects early in the program: for example, evaluation should be made of cabin noise and its effect on communications; of airflow to determine its effect on communications; and of pressure environments that could cause corona. Early evaluations may save many redesigns and retests later in the program.

No schedule benefits will be obtained through greatly reduced reliability and quality requirements. A poor reliability- and quality-assurance program offers apparent schedule and cost advantages, but these advantages soon vanish in the maze of equipment failures and rework efforts that result in unanticipated cost increases and delays.

Ground-support-equipment procurement should be under the control of system engineering at the contractor facility and particularly under the control of the cognizant engineer responsible for the related flight hardware.

Contracts to the second-tier vendor level should be avoided when possible because of the reduction in program visibility and the increase in turnaround response time.

To establish requirements for a system design, all affected organizations (such as flight operations, flight crew support, flight crews, and training) should be represented in the initial design phases of a program. This procedure would reduce the number of changes necessary during later program phases and would reduce cost and schedule impacts.

Quality control and process control should be emphasized strongly, particularly at the component level. Time and money spent on these controls at the beginning of a program will alleviate later schedule slippage and cost increases. (An example is the large number of quality problems regarding integrated circuits and transistors that occurred late in the Apollo Program. In some cases, the quality problems caused equipment retrofitting and schedule slippage.)

Procurement Recommendations

Each procurement activity by the contractor and subcontractors should use a specific design specification for each item purchased and a separate, general environmental-control specification. Each design specification then can reference particular parameters of the environmental-control specification.

To establish packaging uniformity, a packaging specification should be used. The packaging specification should be updated and enforced as a standard mechanical-packaging document. To ensure that assemblies are not damaged during shipment, handling specifications and transportation specifications should be used. Shipping containers should provide protection from all environments during shipment from vendor to contractor.

Design specifications should be more stringent at the black-box level than at the system level so that (after adding all worst-case specification tolerances) end-to-end system requirements will always be met.

The system-engineering requirements should be specified to the vendor as soon as possible, and the vendor should be responsible for the assembly-engineering specification. A system input-output specification is needed before a contract is issued.

Throughout the LM program, continual compatibility problems occurred between flight equipment and GSE. A single vendor for both types of equipment is recommended, and contracts should contain a compatibility requirement.

All signal and control interfaces should be examined by a CCB or a configuration-control panel.

Calibration data should be defined as a function of temperature and voltage range, and the calibration range should be a minimum of five data points.

Processing techniques, inspections, traceability to parts level, and requirements on wire quality should be specified during procurement of integrated circuits.

Testing Recommendations

Time is not saved nor is equipment confidence gained in a qualification-test program that uses qualification hardware not built to production-model requirements. The EVCS-qualification program was very uneventful because of the high quality of the test model. Qualification-test models had to be modified on some of the LM ERA's because the original models were not of final flight configuration.

Heavy emphasis should be placed on early procurement of long-leadtime components so that qualification testing can be early and meaningful enough to support the program. As early in the program as possible, the system should be tested for environmental compatibility (for example, EMI, vibration, and thermal vacuum compatibility). Environmental tests should be performed on the complete spacecraft, insofar as practical. Preinstallation testing should be performed on all flight hardware.

Protective devices should be included in all test equipment that supplies power and signals to flight equipment. Undetectable incipient damage to flight hardware may result if adequate protection is not provided. Protective devices should be provided for exposed equipment such as antennas. Calibrated tools should be provided for all hand operations.

Every effort should be made to ensure commonality between the contractor tests and KSC tests, especially when the tests are identical. Test techniques and equipment differed during the Apollo tests, and correlation of test results was practically impossible.

The Apollo Program experience should be used when qualifying hardware. When the Apollo Program first began, the test programs were numerous and included many environmental tests that later were eliminated. On communications systems, the most meaningful environmental tests were the thermal vacuum, vibration, and shock tests.

Operations Recommendations

Vendor drawings and other documentation should be available during flight operations for real-time troubleshooting or anomaly investigations. Switching of communications modes (at the expense of flexibility) is recommended to prevent a recurrence of the confusion that was caused by improper switch positioning on the LM-3 and LM-4 flights.

Design Recommendations

The communications systems should be pressurized for corona-free operations. Although other corona-suppressing techniques are lighter in weight, variations in workmanship, manufacturing reliability, and quality- and process-control problems can cause repeated rework and redesign. The resulting excessive costs and program impacts could be eliminated if the equipment is pressurized initially.

Do not use inflexible design techniques (for example, cordwood circuits or printed wiring) for critical ERA's (for example, the SPA). Design for flexibility (for example, point-to-point wiring) so that changes can be incorporated with minimum cost and schedule impact.

High-reliability systems should not use electromechanical devices. The first and only EVCS field failure was caused by an RF relay. When the EVCS preliminary-design review was conducted, relays were selected over pin diodes for RF switches. This selection was largely because of contractor-derived trade-offs, which were suspected at the time; but, because of schedule commitments, these trade-offs could not be studied further.

As for system design where a relay technique is employed, total system studies must be performed to ensure that parameters (such as total loop gain, total loop noise, and total VOX time constants) are acceptable. Automatic volume controls should be designed carefully.

Do not braze electronic case structures. For example, SPA and steerable-antenna electronics-box failures occurred because of a marginal braze structural design.

Cases for electronic equipment should be "hogged" out of solid billets. Initially, this process would seem more costly, but (because the strength-to-weight ratio is best) program costs will be less because there will be no crack failures to repair.

Do not use elapsed-time indicators on flight equipment. Experience has shown that test time did not approach operating life and that adequate records were kept on limited-life equipment.

Do not use the "pigtail concept." Bulkhead connectors should be used to improve ERA handling and EMI characteristics.

The effect of cable capacitance on signal performance may sometimes be overlooked. Therefore, close monitoring of this parameter is recommended.

Use coaxial connectors with hex coupling nuts so that they can be torqued easily. Torque all coaxial connectors during installation on the vehicle.

Provide inflight telemetry on critical parameters that normally are not received at the ground station (for example, VHF AGC measurements or communications parameters between spacecraft). This provision would have been extremely helpful in postflight evaluations of communications-system performance.

Give serious consideration to inertial guidance control of any automatic earth-tracking antenna for primary-system tracking. This method would require less crew participation. Circuit complexity also could be reduced, depending on mission requirements.

To reduce the tape budget for onboard voice tape recorders, use VOX control on the recorder.

Use remote multiplexing techniques with digital interfaces to minimize airframe wiring. Use reprogrammable or easily replaceable format generators to minimize changes to airframe wiring caused by measurement requirement changes.

Protect all signal and power inputs against overvoltages up to the maximum voltages permitted by the current state of the art.

CONCLUDING REMARKS

Development of the lunar module communications system began approximately 2 years after the command and service module communications-system development. Although a commonality concept was planned to reduce the impact of the schedule difference, commonality generally proved unfeasible because of the lunar module weight and power restrictions. Also, because of the schedule difference, many of the early developmental and qualification-test programs had to be eliminated or reduced. In fact, the

entire packaging concept was changed and the attendant integration effort was reduced to alleviate schedule problems.

New requirements following the accident involving the first manned command module resulted in significant modifications to the system. Qualification of the system had been accomplished before this time; but, as a consequence of the design changes, delta-qualification tests had to be performed. Delta-qualification tests also were necessary because of the change in workmanship acceptance and related qualification-test vibration levels.

The success of the extravehicular-communications-system program can be attributed to close technical liaison between the Manned Spacecraft Center and the vendor and to a realistic but thorough reliability and quality program that allowed quick reaction and flexibility.

The successful development of the lunar module communications system into an operational system was difficult in many areas, relatively easy in other areas, but challenging in all areas. The missions through the completion of Apollo 11 demonstrated effectivity of the system, compatibility of the system with other lunar module systems and with command and service module and Manned Space Flight Network communications systems, and capability of the system to support a lunar-landing mission. No system failures were encountered during the missions through Apollo 11, and the system has exceeded the operational requirements.

Manned Spacecraft Center
National Aeronautics and Space Administration
Houston, Texas, June 14, 1972
914-13-00-00-72

REFERENCE

1. Rosenberg, Harold R.: Apollo Experience Report — S-Band Systems Signal Design and Analysis. NASA TND-6723, 1972.



NASA 451

POSTMASTER: If Undeliverable (Section 158
Postal Manual) Do Not Return

"The aeronautical and space activities of the United States shall be conducted so as to contribute . . . to the expansion of human knowledge of phenomena in the atmosphere and space. The Administration shall provide for the widest practicable and appropriate dissemination of information concerning its activities and the results thereof."

— NATIONAL AERONAUTICS AND SPACE ACT OF 1958

NASA SCIENTIFIC AND TECHNICAL PUBLICATIONS

TECHNICAL REPORTS: Scientific and technical information considered important, complete, and a lasting contribution to existing knowledge.

TECHNICAL NOTES: Information less broad in scope but nevertheless of importance as a contribution to existing knowledge.

TECHNICAL MEMORANDUMS: Information receiving limited distribution because of preliminary data, security classification, or other reasons.

CONTRACTOR REPORTS: Scientific and technical information generated under a NASA contract or grant and considered an important contribution to existing knowledge.

TECHNICAL TRANSLATIONS: Information published in a foreign language considered to merit NASA distribution in English.

SPECIAL PUBLICATIONS: Information derived from or of value to NASA activities. Publications include conference proceedings, monographs, data compilations, handbooks, sourcebooks, and special bibliographies.

TECHNOLOGY UTILIZATION PUBLICATIONS: Information on technology used by NASA that may be of particular interest in commercial and other non-aerospace applications. Publications include Tech Briefs, Technology Utilization Reports and Technology Surveys.

Details on the availability of these publications may be obtained from:

SCIENTIFIC AND TECHNICAL INFORMATION OFFICE

NATIONAL AERONAUTICS AND SPACE ADMINISTRATION

Washington, D.C. 20546