

## Quality Assurance Project Plan for the Portneuf River Monitoring Project



**Prepared by:**

Three Rivers RC&D Council, Inc.  
1551 Baldy Avenue, Suite 42  
Pocatello, Idaho 83201

**In cooperation with:**

Idaho Department of Environmental Quality  
Pocatello Regional Office  
444 Hospital Way, # 300  
Pocatello, Idaho 83201

and

Rapid Creek Research, Inc.  
220 East 37<sup>th</sup> Street, Suite C  
Boise, Idaho 83714

this page intentionally blank

## Acknowledgements

### Authors

James T. Brock  
Andrew M. Ray

### Editors

Paula Jones  
Irene Nautch

### Contributors

Lynn VanEvery  
Greg Mladenka  
Michelle Byrd  
Katy Flanagan  
Candice Hurt

### Reviewers

1. Richard Inouye, PhD, Department of Biological Sciences, Idaho State University;
2. Mark Masarik, US Environmental Protection Agency
3. Greg Mladenka, Water Quality Scientist, Idaho Department of Environmental Quality;
4. Chikashi Sato, PhD, College of Engineering, Idaho State University;
5. Dan Sharp, Environmental and Floodway Engineer, City of Pocatello;
6. Robert VanKirk, PhD, Department of Mathematics, Idaho State University;
7. John Welhan, PhD, Research Hydrogeologist Idaho Geologic Survey and Idaho State University, Department of Geosciences.

Cover Photo Courtesy of Katy Flanagan (©2003 Mountain Visions)

**A. PROJECT MANAGEMENT**

**A.1. APPROVALS**

Roger Chase, Mayor  
City of Pocatello

\_\_\_\_\_ Date \_\_\_\_\_

Mark Dietrich, Regional Administrator  
Idaho Department of Environmental Quality

\_\_\_\_\_ Date \_\_\_\_\_

Mark Masarik, Project Officer  
US Environmental Protection Agency – Region X

\_\_\_\_\_ Date \_\_\_\_\_

Kent Rudeen, Chairperson  
Three Rivers RC&D Council

\_\_\_\_\_ Date \_\_\_\_\_

James T. Brock, Quality Assurance Manager  
Rapid Creek Research, Inc.

\_\_\_\_\_ Date \_\_\_\_\_

## A.2. TABLE OF CONTENTS

<b>A.</b>	<b>PROJECT MANAGEMENT</b>	<b>3</b>
<b>A.1.</b>	<b>APPROVALS</b>	<b>4</b>
<b>A.2.</b>	<b>TABLE OF CONTENTS</b>	<b>5</b>
	LIST OF TABLES	7
	LIST OF FIGURES	7
<b>A.3.</b>	<b>DISTRIBUTION LIST</b>	<b>8</b>
<b>A.4.</b>	<b>PROJECT ORGANIZATION</b>	<b>10</b>
<b>A.5.</b>	<b>PROBLEM DEFINITION, BACKGROUND AND OBJECTIVES</b>	<b>15</b>
<b>A.6.</b>	<b>PROJECT DESCRIPTION</b>	<b>17</b>
<b>A.6.1</b>	<b>DESCRIPTION OF WORK TO BE PERFORMED</b>	<b>17</b>
<b>A.6.2</b>	<b>SCHEDULE OF WORK</b>	<b>19</b>
<b>A.7.</b>	<b>DATA QUALITY OBJECTIVES AND CRITERIA</b>	<b>20</b>
<b>A.8.</b>	<b>SPECIAL TRAINING REQUIREMENTS / SAFETY</b>	<b>22</b>
<b>A.8.1</b>	<b>TRAINING</b>	<b>22</b>
<b>A.8.2</b>	<b>SAFETY GUIDELINES FOR FIELD ACTIVITIES</b>	<b>22</b>
<b>A.9.</b>	<b>DOCUMENTATION AND RECORDS</b>	<b>23</b>
<b>B.</b>	<b>DATA GENERATION AND ACQUISITION</b>	<b>24</b>
<b>B.1.</b>	<b>SAMPLING PROCESS DESIGN</b>	<b>24</b>
<b>B.2.</b>	<b>SAMPLING METHODS</b>	<b>27</b>
<b>B.2.1</b>	<b>INSTRUMENTATION</b>	<b>27</b>
<b>B.2.2</b>	<b>WATER SAMPLING</b>	<b>29</b>
<b>B.2.3</b>	<b>DISCHARGE</b>	<b>30</b>
<b>B.3.</b>	<b>SAMPLE HANDLING AND CUSTODY</b>	<b>31</b>
<b>B.4.</b>	<b>ANALYTICAL METHODS</b>	<b>32</b>
<b>B.5.</b>	<b>QUALITY CONTROL</b>	<b>33</b>
<b>B.5.1</b>	<b>FIELD QUALITY CONTROL</b>	<b>34</b>
<b>B.5.2</b>	<b>QUALITY CONTROL OF CONTINUOUS MONITORING SYSTEMS</b>	<b>34</b>
<b>B.5.3</b>	<b>LABORATORY QUALITY CONTROL</b>	<b>36</b>
<b>B.5.4</b>	<b>PROCEDURE FOR EXCEEDANCE OF A QUALITY CONTROL LIMIT - FIELD COMPONENT</b>	<b>36</b>
<b>B.5.5</b>	<b>PROCEDURE FOR EXCEEDANCE OF A QUALITY CONTROL LIMIT - LAB</b>	<b>37</b>
<b>B.6.</b>	<b>INSTRUMENT / EQUIPMENT TESTING, INSPECTION, AND MAINTENANCE</b>	<b>37</b>
<b>B.6.1</b>	<b>SONDE CARE AND MAINTENANCE</b>	<b>38</b>
<b>B.6.2</b>	<b>GAGING STATION LEVEL</b>	<b>39</b>
<b>B.7.</b>	<b>INSTRUMENT/EQUIPMENT CALIBRATION AND FREQUENCY</b>	<b>39</b>
<b>B.8.</b>	<b>INSPECTION / ACCEPTANCE OF SUPPLIES AND CONSUMABLES</b>	<b>40</b>
<b>B.9.</b>	<b>NON-DIRECT MEASUREMENTS</b>	<b>40</b>
<b>B.10.</b>	<b>DATA MANAGEMENT</b>	<b>41</b>
<b>B.10.1</b>	<b>FIELD NOTES</b>	<b>41</b>
<b>B.10.2</b>	<b>INSTRUMENT LOG</b>	<b>42</b>
<b>B.10.3</b>	<b>WATER QUALITY DATA HANDLING PROCEDURES</b>	<b>42</b>
<b>C.</b>	<b>ASSESSMENT AND OVERSIGHT</b>	<b>46</b>
<b>C.1.</b>	<b>ASSESSMENT AND RESPONSE ACTIONS</b>	<b>46</b>
<b>C.2.</b>	<b>REPORTS TO MANAGEMENT</b>	<b>48</b>

<b>D.</b>	<b>DATA VALIDATION AND USABILITY .....</b>	<b>48</b>
<b>D.1.</b>	<b>DATA REVIEW, VERIFICATION, AND VALIDATION .....</b>	<b>48</b>
<b>D.2.</b>	<b>VERIFICATION AND VALIDATION METHODS.....</b>	<b>51</b>
<b>D.3.</b>	<b>RECONCILIATION WITH USER REQUIREMENTS .....</b>	<b>52</b>
	<b>REFERENCES .....</b>	<b>54</b>
<b>APPENDIX A</b>	<b>STATE OF IDAHO SURFACE WATER QUALITY CRITERIA.....</b>	<b>56</b>
<b>APPENDIX B</b>	<b>CALIBRATION PROCEDURES FOR YSI SONDES.....</b>	<b>62</b>
<b>APPENDIX C</b>	<b>CALIBRATION PROCEDURES .....</b>	<b>66</b>
<b>APPENDIX D</b>	<b>CALIBRATION WORKSHEET.....</b>	<b>66</b>
<b>APPENDIX E</b>	<b>LIST OF CALIBRANTS AND SUPPLIERS.....</b>	<b>67</b>
<b>APPENDIX F</b>	<b>CURRICULUM VITAE.....</b>	<b>68</b>

## LIST OF TABLES

Table 1. Summary of responsibilities associated with the Portneuf River Monitoring Project.....	12
Table 2. Key Personnel Contact Information and Responsibilities.....	13
Table 3. Anticipated schedule of work to be performed.....	21
Table 4. Summary of document and handling procedures.....	23
Table 5. Locations of monitoring stations.....	25
Table 6. Frequency of sampling for continuous stations.....	26
Table 7. Responsibility for laboratory analyses.....	32
Table 8. Laboratory Analyses of Portneuf River samples.....	33
Table 9. Example data file produced from the Portneuf monitoring station Network.....	45
Table 10. Data grading procedure for continuous monitoring data.....	46
Table 11. Rating continuous water quality records.....	49
Table 12. A comparison of manufacturer’s specifications, USGS allowable limits, and rejection criteria for data from continuous water quality monitoring.....	50
Table 13. Schedule for data evaluation, validation, publication and final archiving of data.....	52

## LIST OF FIGURES

Figure 1. Organizational chart for the Portneuf Monitoring Coalition.....	11
Figure 2. Portneuf River Basin showing flow and water quality monitoring stations.....	18
Figure 3. Systems diagram of continuous quality stations in Portneuf monitoring network.....	28
Figure 4. Field Site Inspection Form.....	42
Figure 5. QA review procedure for water chemistry data.....	43
Figure 6. Quality assurance procedure for continuous monitoring data....	44

### A.3. DISTRIBUTION LIST

1. **Ed Bala**, Idaho Transportation Department, 5151 South 5<sup>th</sup> Avenue, Pocatello, ID 208.239.3300, [Ebala@itd.state.id.us](mailto:Ebala@itd.state.id.us)
2. **James Brock**, Rapid Creek Research, 220 East 37<sup>th</sup> Street, Boise, ID 83714, 208.395-0395, [jtbrock@rcresearch.com](mailto:jtbrock@rcresearch.com)
3. **Kurt Cates**, USDA-Natural Resources Conservation Service, Fort Hall Indian Reservation, P.O. Box 306 Fort Hall, Idaho 83203.
4. **Scott Engle**, USDA-Natural Resources Conservation Service, Portneuf Soil and Water Conservation District, 1551 Baldy Ave., Suite 2, Pocatello, ID 83201 208.237.4628 ex. 112, [scott.engle@id.usda.gov](mailto:scott.engle@id.usda.gov)
5. **Steve Ernst**, Bannock County Planning & Development Services, 130 North 6<sup>th</sup> Avenue, Pocatello, ID 208.236.7230, [stevee@co.bannock.id.us](mailto:stevee@co.bannock.id.us)
6. **Kim Gower**, JR Simplot Company, P. O. Box 912, 1130 W Highway 30 Pocatello, ID 83204, 235-5606, [kgower@simplot.com](mailto:kgower@simplot.com)
7. **Robert Hartman**, FMC Corporation, PO Box 4111, Pocatello, ID 83205, 208.236-8658, [rob\\_hartman@fmc.com](mailto:rob_hartman@fmc.com)
8. **Brent Hokanson**, City of Pocatello Water Pollution Control Facility, Box 4169, Pocatello, ID 83204, 208.234.6256, [bhokanson@pocatello.us](mailto:bhokanson@pocatello.us)
9. **Candice Hurt**, City of Pocatello Water Pollution Control Facility, Box 4169, Pocatello, ID 83204, 208.234.6256, [churt@cityofpocatello.org](mailto:churt@cityofpocatello.org)
10. **Richard Inouye**, Department of Biological Sciences, Box 8007, ISU, Pocatello, ID, 208.282.2933, [inourich@isu.edu](mailto:inourich@isu.edu)
11. **Lee Leffert**, USDA Forest Service Caribou-Targhee National Forest, 1405 Hollipark Dr., Idaho Falls, ID 83403, 557-5783, [lleffert@fs.fed.us](mailto:lleffert@fs.fed.us)
12. **Justin Krajewski**, Idaho Soil Conservation Commission, 1551 Baldy Avenue, Suite 2, Pocatello, ID 83201, 208.237.4628, [jkrajews@agri.state.id.us](mailto:jkrajews@agri.state.id.us)
13. **Mark Masarik**, U.S. Environmental Protection Agency-Region X, 1435 N. Orchard, Ste. 100, Boise, ID 83706, 208.378.5761 [Masarik.mark@epa.gov](mailto:Masarik.mark@epa.gov)
14. **Larry Mickelson**, USDA Natural Resources Conservation Service, Caribou Soil Conservation District, 159 East 2<sup>nd</sup> South #4, Soda Springs, ID 83276, 208.547.4801 [larry.mickelson@id.usda.gov](mailto:larry.mickelson@id.usda.gov)
15. **Debra Mignogno**, US Fish and Wildlife Service, Ecological Services 4425 Burley Drive, Chubbuck, ID 83202, 208.237.6975 [debbie\\_mignogno@fws.gov](mailto:debbie_mignogno@fws.gov)
16. **Greg Mladenka**, Idaho Department of Environmental Quality, Pocatello Regional Office, 444 Hospital Way #300, Pocatello, ID 83201, 208.236.6160, [gmladenk@deq.state.id.us](mailto:gmladenk@deq.state.id.us) ;
17. **Andrew Ray**, Department of Biological Sciences, Box 8007, Idaho State University, Pocatello, Idaho 83209. 208.282.4831 [rayandr@isu.edu](mailto:rayandr@isu.edu).
18. **Mike Rowe**, Idaho Department of Environmental Quality, Pocatello Regional Office, 444 Hospital Way #300, Pocatello, ID 83201, 208.236.6160, [mrowe@deq.state.id.us](mailto:mrowe@deq.state.id.us)



19. **Kent Rudeen**, Three Rivers RC&D, 1551 Baldy Avenue, Pocatello, ID, 208.237.5041, [krudeen@dcdi.net](mailto:krudeen@dcdi.net)
20. **Chikashi Sato**, College of Engineering, Box 8060, ISU, Pocatello, ID 83209, 208.282.4839, [satochik@isu.edu](mailto:satochik@isu.edu)
21. **Richard Scully**, Idaho Department of Fish and Game, 1345 Barton Road, Pocatello, ID 208.232.4703 [rscully@idfg.state.id.us](mailto:rscully@idfg.state.id.us)
22. **Dan Sharp**, PO Box 4169, City of Pocatello, Pocatello, ID 83205 208.234.6227, [dsharp@pocatello.us](mailto:dsharp@pocatello.us)
23. **Sue Skinner**, U.S. Environmental Protection Agency- Region X, 444 Hospital Way, Suite 300, Pocatello, ID 83201, 208.478-1680, [skinner.susan@epa.gov](mailto:skinner.susan@epa.gov)
24. **Steve Smart**, City of Chubbuck, 5160 Yellowstone Avenue, Chubbuck, ID 83202, [smarstev@ci.chubbuck.id.us](mailto:smarstev@ci.chubbuck.id.us)
25. **Elise Teton**, Shoshone Bannock Tribes Water Resources Department, Water Quality Program, PO Box 306, Fort Hall, ID 83203; 208.478.3906, [eteton@shoshonebannocktribes.com](mailto:eteton@shoshonebannocktribes.com)
26. **Lynn VanEvery**, Idaho Department of Environmental Quality, Pocatello Regional Office, 444 Hospital Way Suite 300, Pocatello, ID 83201, 208.236.6160, [lvanever@deq.state.id.us](mailto:lvanever@deq.state.id.us)
27. **John Welhan**, Department of Geosciences, Box 8072, ISU, Pocatello, ID 83209, 208.282.4254, [weljohn@isu.edu](mailto:weljohn@isu.edu)
28. **Chris Wilhelm**, Department of Biological Sciences, Box 8007, Idaho State University, Pocatello, Idaho 83209. 208.282.4831, [wilchri@isu.edu](mailto:wilchri@isu.edu)
29. **Scott Henderson**, Portneuf Soil and Water Conservation District, 1551 Baldy, Suite 2, Pocatello, ID 83201, 208-237-4628 ext. 121, [jmbaker@micron.net](mailto:jmbaker@micron.net)

#### **A.4. PROJECT ORGANIZATION**

Three Rivers Resource Conservation and Development Council (Three Rivers RC&D) in cooperation with the Idaho Department of Environmental Quality (IDEQ) and Rapid Creek Research have prepared the Quality Assurance Project Plan (QAPP) for the Portneuf River Monitoring Project on behalf of the Portneuf Monitoring Coalition (PMC). The PMC is a cooperative effort by private industry, educational institutions, scientists, and government agencies at numerous levels (City, County, State, Tribal, and Federal) to monitor water quality and ecological conditions in the Portneuf River. An individual, agency, or other entity may contribute to the work of the PMC by funding part(s) of the project or by participating in the coalition.

The monitoring network grew out of data collection activities initiated in 1998 by the City of Pocatello to monitor the impacts of its wastewater treatment facility (Pocatello WWTF) on the Lower Portneuf. Originally comprised of a pair of stations, one above and the other below the Pocatello WWTF, the system expanded in 2001 with the addition of two more continuous monitoring systems to characterize water quality above and below the Pocatello-Chubbuck urban area.

As the scope of the monitoring program broadened, so did the number of participating stakeholders. With four monitoring stations operational, the City of Pocatello, the City of Chubbuck, and the Water Resources Department, Water Quality Program of the Shoshone-Bannock Tribes joined forces with Idaho DEQ, Idaho State University, and Three Rivers RC&D to apply for a Regional Geographical Initiative (RGI) grant from USEPA Region X. In 2001, this RGI grant initiative was successful with Three Rivers RC&D serving as the administering agency. The formation of the PMC evolved out of the need to coordinate monitoring interests among the various government agencies, the Shoshone Bannock Tribes, the University, and private industry. In 2002, a second RGI grant was funded by EPA. As of July 2004, the monitoring network consists of seven regularly monitored stations.

The goal of the RGI is to provide funding for necessary equipment and personnel and an incentive for organizing agencies and stakeholders in the region to address and solve environmental problems. As such, it does not have a formal organizational structure beyond that involved in administration of the Federal grant. The organizational chart below (Fig. 1) displays the hierarchy of the various project participants. The Greater Portneuf Water Resource Partnership (GPWRP) is a broader based coalition of stakeholders interested in the surface and groundwater resources of the Greater Portneuf Basin and has oversight of several other grant-funded projects.

Table 1 shows contributions and responsibilities of each project participant, with regard to program design, field sampling, laboratory analysis, etc. These are the entities represented in the PMC.

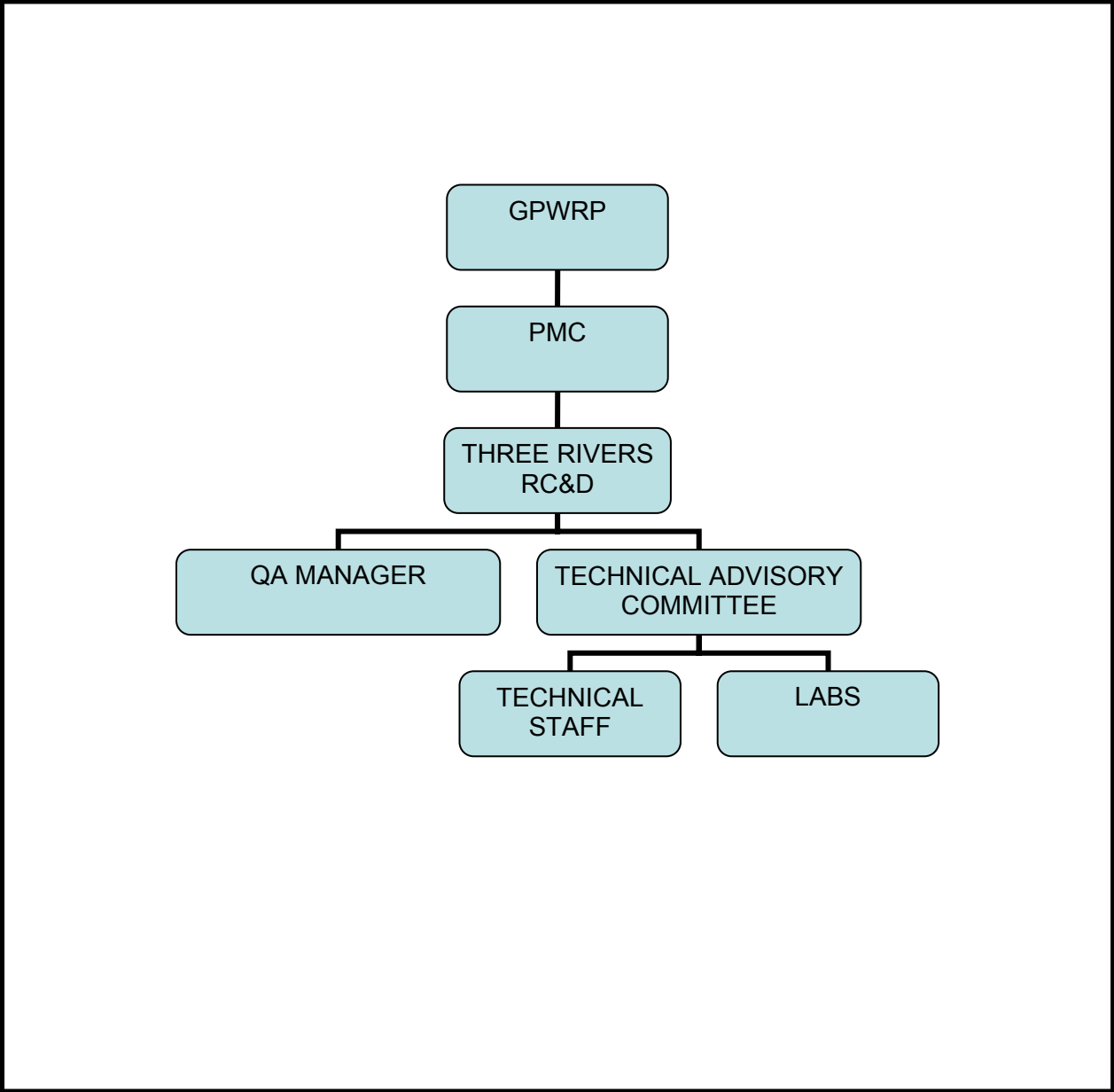

**Figure 1. Organizational chart showing the key entities involved in all major aspects of the Portneuf River Monitoring Project.**

**Table 1. Summary of responsibilities associated with the Portneuf River Monitoring Project**

Agency, University, Corporation or Other Entity	Program Design	Field Sample Collection	Analytical Laboratory Analysis Services	Data Base Entry	Data Review and Analysis	Program Quality Assurance Review	Web Site Maintenance	Program Technical Review	Program Educational Outreach	Program Administration	Program Oversight/Funding
City of Pocatello Water Pollution Control Dept Public Works Dept	■	■	■	■	■	■		■	■		■
Energy Laboratories			■								
Idaho Dept of Environmental Quality	■	■			■	■		■			■
Idaho State University		■	■						■		
J.R. Simplot Co.											■
Rapid Creek Research (1)	■	■		■	■	■	■	■			
Shoshone Bannock Tribes (2)		■			■	■		■	■		
Three Rivers RC&D (3)	■	■		■	■	■		■	■	■	■
US EPA						■					■

- Notes: 1. Contractor to City of Pocatello, Idaho DEQ, Three Rivers RC&D  
 2. Pending approval from Fort Hall Business Council  
 3. RC&D Contractors – Andrew Ray, Chris Wilhelm, Irene Nautch

A multidisciplinary team of technically qualified staff and senior scientists will be used to complete all responsibilities of the Portneuf River Monitoring Project. Key individuals and their primary responsibilities in the Portneuf River Monitoring Project are outlined in Table 2. The project manager acts as the local administrator of work addressing staffing and budgetary considerations associated with monitoring activities. The project manager is also responsible for maintaining the official, approved QAPP, and coordinating with the grant administrator on questions related to project management. The quality assurance (QA) manager supervises all quality assurance procedures while senior staff provides technical oversight for maintenance and management of the continuous monitoring network, water sampling, discharge measurements, data review, report generation, and training of technical staff and volunteers. Technical staff is responsible for water sampling, discharge measurements, and supervision of volunteers involved with field sampling activities. Local water resource professionals (agency and university) participated by providing peer review of earlier drafts of this document (see Section A3).

Numerous members of the Greater Portneuf Water Resource Partnership participate in monitoring discussions and offer field assistance when called upon. However, only those individuals involved in routine activities associated with the monitoring program described herein are included in Table 2.

**Table 2. Key Personnel Contact Information and Responsibilities**

Name	Title and Responsibilities
<b><i>US Environmental Protection Agency</i></b>	
Mark Masarik 208.378.5761 <a href="mailto:masarik.mark@epa.gov">masarik.mark@epa.gov</a>	<i>Project Officer</i> – EPA official who provides technical and programmatic oversight and who is designated in the assistance agreement as EPA’s program contact with the recipient. The PO is responsible for ensuring assistance agreements meet scientific, technical and programmatic requirements.
Roy Araki 206-553-6395 <a href="mailto:araki.roy@epa.gov">araki.roy@epa.gov</a>	<i>Quality Assurance Manager</i> – EPA official who assists in establishing the QA requirements for assistance agreements and in ensuring the requirements are met. the QAM also reviews and approves QAPPs submitted by the grantee.
<b><i>Three Rivers Resource Conservation and Development</i></b>	
Paula A. Jones 208.237.5041 <a href="mailto:Paula.Jones@id.usda.gov">Paula.Jones@id.usda.gov</a>	<i>Project Manager</i> – coordinates project activities and is in regular contact with the project officer, grant administrator, technical advisors/staff and is responsible for maintaining and distributing the official, approved QAPP. The PM establishes relationships with stakeholders of the Portneuf River and works to identify future funding sources to sustain monitoring activities.

Andrew M. Ray 208.282.4831 <a href="mailto:rayandr@isu.edu">rayandr@isu.edu</a>	<i>Water Quality Monitoring Scientist</i> – provides technical oversight and field assistance with all sampling activities. The scientist will coordinate volunteer activities including training sessions and scheduling of sampling activities.
Chris Wilhelm 208.282.4831 <a href="mailto:wilhchri@isu.edu">wilhchri@isu.edu</a>	<i>Water Quality Monitoring Technician</i> – responsible for the maintenance of the continuous monitoring network. The technician assists with field sampling and discharge measurement and supervision of volunteers.
Irene Nautch 208.237.8637 <a href="mailto:irene@allidaho.com">irene@allidaho.com</a>	<i>Data Analyst</i> – acts as the primary editor for technical reports and documents, enters data from field books, reviews trend plots to help identify problems, and reviews chemistry and sonde data for quality assurance.
<b>Rapid Creek Research, Inc.</b>	
James T. Brock 208.395.0395 <a href="mailto:jtbrock@rcresearch.com">jtbrock@rcresearch.com</a>	<i>Quality Assurance Manager, Senior Scientist</i> - supervises all QA/QC procedures for continuous monitoring instrumentation, water sampling and discharge measurements, data review, report generation, and training of technical staff and volunteers on an annual basis. Primary activities of the QA manager, also the senior technical advisor, include data review and analysis, web site maintenance, instrumentation design and maintenance, and oversight of all field sampling activities. The senior scientist also acts as an author and primary reviewer of all technical documents.
<b>Idaho Department of Environmental Quality</b>	
Lynn VanEvery 208.236.6160 <a href="mailto:lvanever@deq.state.id.us">lvanever@deq.state.id.us</a>	<i>Regional Water Quality Manager, Senior Scientist.</i> – provides technical oversight of all field sampling activities and coordinates with the project manager on budgetary and administrative issues. The RWQM also acts as a contributor and primary reviewer of all technical documents.
Greg Mladenka 208.236.6160 <a href="mailto:gmladenk@deq.state.id.us">gmladenk@deq.state.id.us</a>	<i>Water Quality Scientist</i> - provides technical oversight and field assistance with all sampling activities. WQ scientist coordinates all sampling activities with monitoring technicians and assists with volunteer training opportunities and scheduling of sampling activities. The scientist also is a primary reviewer of all technical reports.
<b>City of Pocatello</b>	
Candice Hurt 208.234.6256 <a href="mailto:churt@cityofpocatello.org">churt@cityofpocatello.org</a>	<i>Laboratory Coordinator</i> – provides technical oversight for sample collection and assists with field sampling activities. The laboratory coordinator acts as the Portneuf River Monitoring Project's primary contact for ENERGY Laboratories, Inc. and provides QA oversight for sample handling and custody, and analytical methods.

## **A.5. PROBLEM DEFINITION, BACKGROUND AND OBJECTIVES**

The Portneuf River Monitoring Project enables stakeholders to assess and document the influence of natural and human-caused factors on water quality. This document describes the development and implementation of the Portneuf River Monitoring Project and defines the standards and methods used to ensure consistent sampling procedures and that data generated during field activities are accurate, complete and representative of actual riverine conditions.

The Portneuf River originates in the high country on lands of the Shoshone-Bannock Tribes. After flowing about 100 miles, the Portneuf River joins the Snake River at the Fort Hall Bottoms, which is also on Tribal land. The Cities of Pocatello and Chubbuck (combined population ~ 60,000) comprise the primary human population center in this 1,360 square mile basin; several smaller towns are located in the upper agricultural portion of the drainage.

The Portneuf River has numerous documented water quality problems. It was placed on the U.S. Environmental Protection Agency's (EPA) 303(d) list in 1998. A 303(d) listing means that a water body has been identified as being impaired with respect to attainment of beneficial uses. The listing identified elevated concentrations of bacteria, nutrients, sediment, and substantial flow alteration. In addition, the reach of the river extending downstream from Johnny Creek to the Fort Hall Reservation Boundary was also listed for excessive amounts of oil and grease.

IDEQ also considers 27 water body segments in the Portneuf Basin as impaired and subject to pollutant reductions in the Total Maximum Daily Load (TMDL) program. Parameters of concern include sediment, nutrients, bacteria, flow alteration, temperature, and dissolved oxygen (DO). Sources include agriculture (flow alteration, sediment, nutrients, and bacteria), urban areas (sediment, nutrients, and bacteria), wastewater treatment facilities (nutrients), and groundwater (nutrients), which has been influenced by industrial impacts (IDEQ, 2004). Numeric standards for surface water are defined in Idaho Administrative Code 58.01.02 (see Appendix A). The Portneuf TMDL document approved in 2001 defines criteria for sediment and nutrients. Sediment loads are set at 50 – 80 mg/L total suspended solids, depending on season and location. Total phosphorus and total inorganic nitrogen limits are set at 0.075 and 0.3 mg/L, respectively.

The Portneuf monitoring project is generating information that is essential to the success of TMDL implementation. Extensive monitoring data and information on the quality of water and associated biota provide the foundation for the TMDL program, pollutant loading assessment, effectiveness monitoring of Best Management Practices (BMP), and ultimately de-listing of the 303(d) waters.

## Objectives

The objectives of the monitoring program are to:

- quantify existing conditions allowing trend analysis of water quality and ecosystem health over time,
- develop a better understanding of the magnitude of point and non-point pollutant loadings to the river,
- provide information that will help the City of Pocatello meet National Pollutant Discharge and Elimination System (NPDES) permit regulations and manage storm water and wastewater,
- assess suitability of standards and compliance with water quality objectives that support beneficial uses, reduce monitoring costs and improve data quality,
- help determine when conditions in a water body segment have improved to the point that it can be de-listed,
- provide supplementary information on river flows, both minimum and flood conditions, and
- support development of simulation models, TMDL plans, and potentially serve as the surface water component for protecting the Portneuf regional groundwater aquifer.

These objectives have been discussed and developed by stakeholders of the Portneuf Basin during a series of workshops held to address TMDL issues.

## Limitation of Scope

This Quality Assurance Project Plan has been formulated to describe regular monitoring activities of the Portneuf River Monitoring Project. The Portneuf monitoring activities can be divided into two categories: “core activities” and “special studies.” The core or routine activities include development and maintenance of continuous monitoring stations and regular stations (e.g., monthly collection of sonde data and laboratory samples from established stations) and monitoring of ambient water quality required by the NPDES permit holder, the City of Pocatello Wastewater Treatment Facility.

Several related, but non-core topics of the monitoring program have been explicitly excluded from this QAPP. These ancillary topics are listed below:

- *Water Quality and Quantity Modeling* - Monitoring data from this project may be used to support other activities such as simulation modeling of surface water in the Portneuf Basin. However, simulation modeling is not an integral part of the monitoring program nor is it funded by current RGI project funds. Therefore this QAPP does not address the topic of modeling activities.
- *Special Studies* - Special studies may be conducted by participants of the PMC on an irregular basis as the need and resources (time, personnel, and funds) allow. An example of a special study is the



sampling of a major runoff event, or synoptic sampling of numerous stations during hot weather and drought flows. Sampling and analysis procedures during special studies will generally follow those established for the regular monitoring program, however there may be exceptions based on conditions at the time of the activity. Special studies are not funded by the current RGI grant and are not explicitly described in this QAPP.

Additional information on project elements is provided in Section A6.1.

## **A.6. PROJECT DESCRIPTION**

The purpose of this plan element is to summarize work to be performed, provide a work schedule and map, describe geographic locations to be studied and discuss resource and time constraints.

### **A.6.1 DESCRIPTION OF WORK TO BE PERFORMED**

The Portneuf River Basin, located in southeastern Idaho, has an area of approximately 1,300 square miles, which sustains a river length of approximately 97 miles (Figure 2). The river flows through a region of southeastern Idaho that is characterized by low levels of precipitation, < 30 cm annually, of which most is delivered in the form of snow, and therefore the river is heavily supported hydrologically by melting of the snow pack and aquifer exchange. The average summer discharge is approximately 500 cfs during peak runoff, falling to 50 cfs in summer, a drop of one order of magnitude (Minshall and Andrews, 1973). The major tributary to the Portneuf River is Marsh Creek, with smaller tributaries including Rapid Creek, Mink Creek, and Pocatello Creek (Figure 2).

The Portneuf River Basin supports mixed land uses including agriculture, industrial, and urban. The Portneuf River monitoring network was established to characterize the effects of these mixed uses and their combined impact on river water quality. Figure 2 illustrates the spatial distribution of the seven continuous monitoring stations. Six of the stations are positioned along the length of the Portneuf River and the remaining station is located on Marsh Creek. The geographic location of each station is provided in Section B1 including the geographic locations of the US Geological Survey's gaging stations.

The Portneuf River monitoring program, consisting of six elements, is described briefly below.

**1) Continuous water quality monitors** - The sonde is an electronic device containing up to five different sensors that measure water quality constituents including temperature, specific conductance, DO, pH, and optical turbidity. Measurements are made every ten minutes and hourly means are reported in final data files. Measurements are recorded using a field computer called a data logger. The data logger is linked to an office computer using either

# Portneuf River Basin

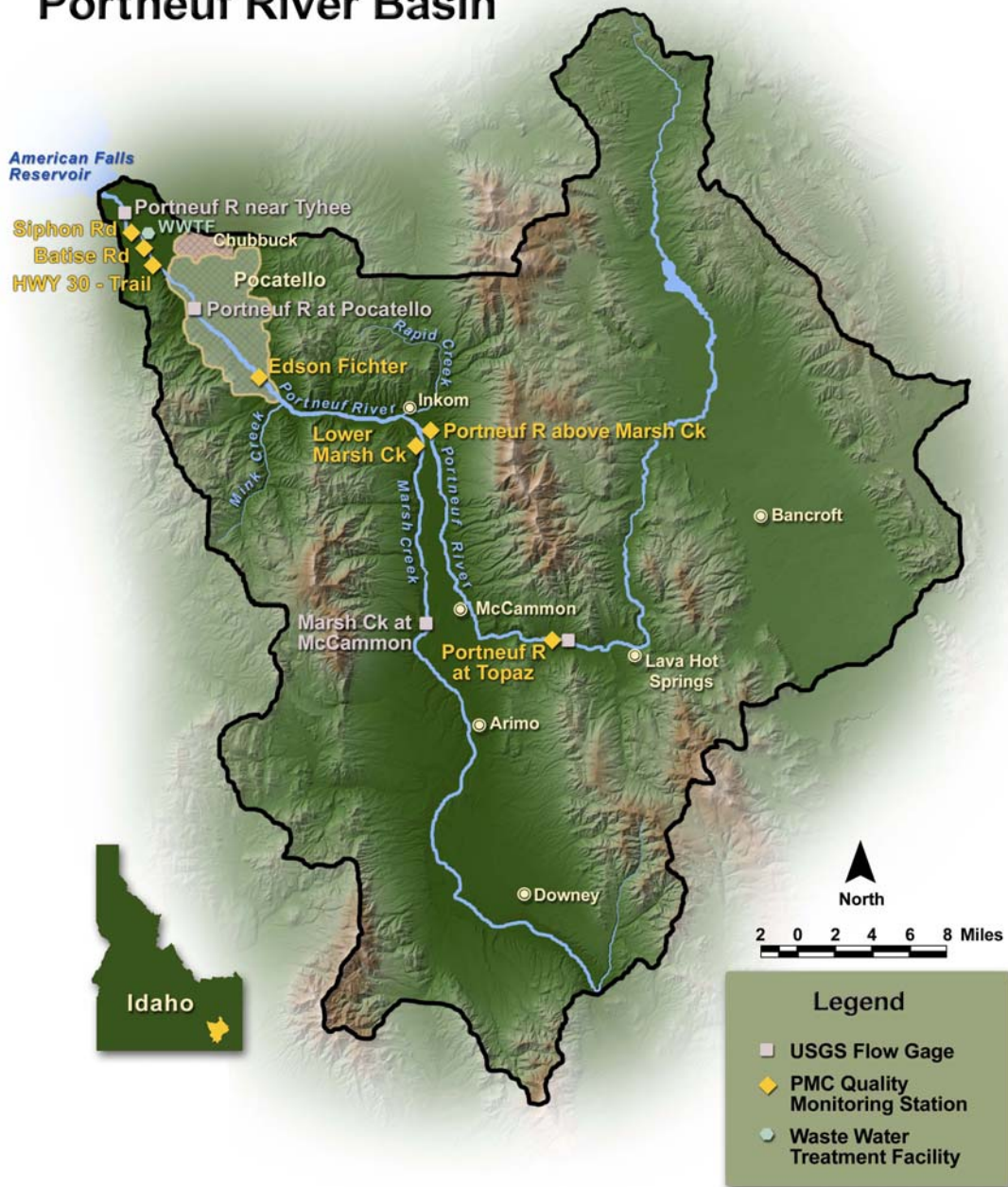

Figure 2. Portneuf River Basin showing flow and water quality monitoring stations.

telephone or radio. A photovoltaic panel provides electrical power to the monitoring station. Trend plots are maintained on a web site, which is updated every few hours.

**2) Water Quality Samples** – Water samples are collected from monitoring stations monthly during ice-free periods (normally March through December) coinciding with NPDES requirements for the Pocatello WWTF. Chemical and physical characteristics of the samples are determined by laboratory analysis. A minimum of 10 samples per site, per year is taken. Batise, Siphon and Pocatello WWTF outfall generally do not freeze over during winter months and are sampled monthly for the entire year. Additional samples are taken during spring runoff or other event driven runoff as resources allow, however these events vary seasonally and yearly. Therefore, sampling activities associated with runoff events are unpredictable.

**3) Discharge** – River discharge is measured at four gaging stations by means of continuous water level recorders that are calibrated by regular field measurements of velocity and depth at flow control points (Fig. 2). These stations supplement the gaging network maintained in the basin by USGS.

**4) Quality Assurance** – A goal of the PMC is to ensure that information collected by the monitoring network will provide a scientifically defensible basis for the PMC and others to make inferences on the integrity of the Portneuf River ecosystem. This document addresses standard practices used for maintaining quality of information collected and provides detailed explanations of requirements necessary for QAPP compliance. Specifically, this QAPP outlines descriptions of procedures for routine cleaning and calibration of sonde sensors, acceptance criteria for calibrated and deployed instrumentation, procedures for collection of water samples, and guidelines for review and acceptance of data generated by the continuous monitoring systems.

**5) Data Presentation and Distribution** – An additional goal of the PMC was to make real time data collected at each monitoring site available to the public, viewable in near real time at [WWW.PORTNEUFIVER.ORG](http://WWW.PORTNEUFIVER.ORG). Having the QAPP guidelines published and implemented during collection and review of water quality information is fundamental to ensuring that sound procedures are in place and resources are expended wisely. Once long term data are screened and verified they are made available on the project web site.

**6) Data Analysis** - This aspect of the project involves preparation of trend charts and calculation of pollutant loadings.

#### **A.6.2 SCHEDULE OF WORK TO BE PERFORMED**

The work to be performed for this project includes collection of monitoring data, construction of two additional stations to augment the program, station

maintenance, data screening, and preparation for publication. Primary tasks and target completion dates are provided in Table 3.

**Table 3. Anticipated schedule of work to be performed.**

<b>Task</b>	<b>Target Completion Date</b>
Sampling and collection of monitoring data	Ongoing, beginning in 2001
Hiring technical staff	November 2001, July 2003
Making all mainstem Portneuf River Stations Operational	December 2003
Making Lower Marsh Creek Station Operational	March 2004
Establishing Volunteer Program	February 2004
Posting of Historic Data onto Web site	July 2004
Local Approval of Final QAPP and submittal to EPA	August 2004
Publishing Monitoring Data through 2002	August 2004
Making Bannock Creek Station Operational	May 2005
Publishing Data through 2003	November 2004
Publishing Data through 2004	March 2005

#### **A.7. DATA QUALITY OBJECTIVES AND CRITERIA**

Data quality objectives for the Portneuf River Monitoring Project are to produce scientifically defensible data that meet monitoring objectives of the participating stakeholders (see Section A5). This involves establishing and meeting goals for precision, accuracy, representativeness, completeness, comparability, bias and sensitivity. In general, our objective is to standardize where possible, and document otherwise (Puckett, 2002).

**Precision** – Precision is a measure of agreement among individual measurements of the same property under identical or substantially similar conditions. Replicate samples (typically duplicates) shall be collected for all constituents at an annual rate of 5% of the total number of samples collected.

**Accuracy** – Accuracy is a measure of agreement between an analytical measurement and a reference of a known value. Field blanks shall be collected at an annual rate of ~5% of the total number of samples collected.

**Representativeness** – The measure of the degree to which data accurately and precisely represent constituent variations at a sampling point is its representativeness. Water flowing past a given location on land is constantly changing in response to a suite of environmental factors. Sampling strategies, equipment, and schedules will be designed to maximize *representativeness* where possible and applicable.

**Completeness** –The quantity of valid data available for use compared to the amount of potential data constitutes a measure of *completeness*. In an ambient water quality monitoring program 90% completeness is a reasonable goal. This can be calculated by dividing the number of samples with acceptable data by the total number of samples planned to be collected and multiplying the result by 100. Some samples collected for chemical analysis are covered under a NPDES Permit. The objective of the monitoring program is to have 100% of samples collected and analyzed to be valid. Monthly sampling will be scheduled during the first two weeks of the month, so if in any case samples are invalid or incomplete, repeat sampling and analysis can be completed prior to the end of the month.

**Comparability** – Comparability is a measure of the confidence with which one data set or method can be compared to another. Standard methods and sampling techniques will be used to assess comparability (APHA, 1998; Shelton, 1994). Our objective is to have continuous monitoring equipment operational  $\geq 80\%$  of the time. Continuous monitoring constituents include water temperature, DO, pH, specific conductance and turbidity.

**Bias** - Inherent in any sampling program are potential sampling biases or prejudices. A goal of this QAPP is to describe guidelines that will eliminate or minimize the amount of sampling bias introduced into the Portneuf River Monitoring Project. Several types of sampling biases exist. However, two primary types are often described, and they are experimenter bias and systematic bias (Dean and Voss, 1999).

Sampling biases can arise from a number of sources, a few of which are listed below,

- failure to adhere to the random or representative sampling techniques.
- intentional omission of subgroups of the sampled population (or portions of the cross-section in reference to river sampling), and
- faulty, poorly calibrated or uncalibrated instrumentation used for measuring.

Senior field staff will advise all technical staff and volunteers of the importance of randomization and representativeness in sample collection



and will address the potential for introducing sampling bias during formal training sessions.

**Sensitivity** – Sensitivity is the capability of a method or instrument to discriminate between measurement responses representing different levels of a variable of interest.

Generally speaking, quality assurance is achieved in the Portneuf Monitoring Project by implementing the following measures:

- development of the Quality Assurance Project Plan (QAPP; this document)
- review of the QAPP by local technical experts and approval by participating stakeholders,
- implementing a quality assurance (QA) program for laboratories including lab and field performance checks.

Any measurements made during the Portneuf Monitoring Project employ only methods and techniques determined to produce measurement data of a known and verifiable quality sufficient to meet the overall objectives of the water quality monitoring investigation.

## **A.8. SPECIAL TRAINING REQUIREMENTS / SAFETY.**

### **A.8.1 TRAINING**

Proper training of field personnel, including volunteers, is a critical aspect of quality control. Field technicians are trained by senior monitoring staff using written standard operating procedures. Personnel are trained in the use of hydrologic equipment that includes, but is not limited to, electronic water testing instruments, field computers, current velocity meters, and depth integrating sediment samplers. A minimum qualification of personnel is training or coursework equivalent to eight semester hours of formal course work in the aquatic sciences. Personnel must be capable of performing activities in a field setting that includes walking or traveling over snow up to 1/2 mile from vehicular access. Computer skills involve basic spreadsheet, data entry, and some statistical analysis capability.

The quality assurance manager evaluates field procedures and instrument calibration at least once per year. Any deficiencies and procedural suggestions that are noted will be documented in writing, with steps taken to rectify the deficiencies. Records will be kept by Three Rivers RC&D.

### **A.8.2 SAFETY GUIDELINES FOR FIELD ACTIVITIES**

Field personnel are trained in standard safety procedures for river monitoring activities. Proper field and laboratory safety procedures are followed with respect

to chemicals (e.g., preservatives), and safety equipment (e.g., safety glasses, protective footwear). Personal flotation devices shall be worn when wading in water deeper than 2 feet. All personnel shall have active Red Cross First Aid training. Records will be kept by Three Rivers RC&D.

**A.9. DOCUMENTATION AND RECORDS**

A fundamental purpose of the monitoring project is to collect, analyze and disseminate data on characteristics of the Portneuf River. Project data include handwritten and computer generated field notes, electronic data files from continuous monitoring equipment, and results of laboratory analyses. Primary data are compiled, edited, entered into computer databases, and made available as archived databases and summary reports.

All field data gathered in the monitoring program shall be recorded either in bound field notebooks or standardized data forms. The primary data entries shall be photocopied on a regular (minimum monthly) basis to provide a backup copy. Hard copies of data shall be maintained at two separate locations, the Pocatello WWTF Laboratory and the IDEQ office.

An information management system for the monitoring program shall be developed to include paper copies of field data notebooks and forms, laboratory analytical data, field instrument calibration notebooks, and electronic data collected from the continuous monitoring equipment.

A summary of how project documents will be tracked, filed, and archived is provided in Table 4.

**Table 4. Summary of document and handling procedures for Portneuf Monitoring Project.**

<b>Description</b>	<b>BackUp</b>	<b>Archived/Storage</b>	<b>Retention Period</b>
Field books or Field Data Forms	Field books and forms photocopied and retained in binder	Note 1	7 years
Computer field notes	Copied weekly	Note 1	7 years
Chain of Custody Forms	Kept with laboratory results	Note 1	7 years
Laboratory Notebooks	Per Laboratory Quality Assurance Plan		7 years
Laboratory Results	Entered to data base.	Note 1	7 years
Continuous Monitoring Data	Copied to off-site server.	Note 1	7 years

Notes: 1. One copy retained at Pocatello WWTF Laboratory, Second at Idaho DEQ in Pocatello.

Three Rivers RC&D is responsible for conducting an annual review and update of the QAPP, and will disseminate updated versions to those on the distribution list.

## **B. DATA GENERATION AND ACQUISITION**

### **B.1. SAMPLING PROCESS DESIGN**

Lotic ecosystems, including the Portneuf River, are variable in both time and space. River characteristics often change radically from their headwaters to tail waters and therefore, multiple sampling locations are required to characterize discharge, chemical and sediment loads. In order to capture the spatial variability of the Portneuf River, the Portneuf River Monitoring Project contains seven continuous monitoring locations; six locations are on the Portneuf River and one location is on Marsh Creek, its major tributary. Depth integrated samples are collected across the width of the channel, thereby addressing the spatial variability that may exist at the sample site,

Permanent monitoring sites are shown in Figure 2, with location information provided in Table 5. Monitoring stations have been situated at key locations to provide data on water quality conditions as follows:

- a) Upper Basin (Portneuf River at Topaz – Portneuf Marsh Valley Canal; Major irrigation diversion)
- b) Upper Basin Main Forks (Portneuf River above Marsh Creek and Marsh Creek below Walker Creek);
- c) Above Pocatello-Chubbuck urban area (Portneuf River at Edson Fichter)
- d) Below Pocatello-Chubbuck urban area, above influence from springs (Highway 30 Trail),
- e) Above Pocatello WWTF (Portneuf River at Batisse Rd)
- f) Below Pocatello WWTF and Springs (Portneuf River at Siphon Rd)
- g) Outfall of Pocatello WWTF (this is monitored as part of the WWTF discharge permit)

All monitoring sites have been georeferenced using Global Positioning Systems (Table 5). Locations have been archived and used to identify the specific sampling location at each station. For all sites located on private property, permanent access agreements have been developed and are on file at Three Rivers RC&D and IDEQ. Remaining sites are on public property and therefore, access to sites is guaranteed.

RGI project funds will be used to install an additional station on Bannock Creek by May 2005. This planned monitoring station at Bannock Creek is adjacent to, but not contained within the Portneuf River basin. This station is included within the Portneuf Monitoring Project because of its proximity to Pocatello and its applicability to the management of loads to American Falls Reservoir.



**Table 5. Locations of monitoring stations in the Portneuf River Monitoring Network**

Station Name	Location	Station No.	River Mile	Latitude North	Longitude West
<b>a. Continuous Quality Monitoring Station</b>					
Portneuf River at Topaz	Portneuf Marsh Valley Canal Diversion		48.9	42.624394013	-112.117096506
Lower Marsh Ck	below Walker Ck			42.782005269	-112.237091747
Portneuf River above Marsh Ck			33.5	42.782320331	-112.230441791
Portneuf River at Edson Fichter	Edson Fichter Nature Area		22.5	42.822078058	-112.403604500
Portneuf River at HWY 30 – Trail	Bridge		13.5	42.906959574	-112.511025319
Portneuf River at Batise Rd.	Bridge		13.4	42.913303741	-112.519835010
Portneuf River at Siphon Rd.	Bridge		11.0	42.935166076	-112.544059610
Pocatello Wastewater Treatment Facility	Outfall		12.9	42.919574248	-112.521173484
Bannock Ck (proposed)					
<b>b. USGS Discharge Gaging Station</b>					
Marsh Creek near McCammon		13075000		42.63	-112.22
Portneuf River at Topaz, ID		13073000	55.5	42.624394013	-112.117096506
Portneuf River at Pocatello, ID	Carson St.	13075500	16.8	42.871676476	-112.466944669
Portneuf River near Tyhee, ID		13075910	9.8	42.944722222	-112.544166667

Notes: 1. Datum is NAD27  
 2. Topaz and Lower Marsh Ck. coordinates require attention (jtb)

A minimum of 10 samples per site, per year is taken. Batise, Siphon and Pocatello WWTF outfall generally do not freeze over during winter months and are normally sampled all year as indicated. At these sites 12 samples are taken per year, while the remainder of the sites are sampled a minimum of 10 times per year. Additional samples are taken during spring runoff or other event driven runoff as resources allow (Table 4), however these events vary seasonally and yearly. Therefore, sampling activities associated with runoff events are unpredictable.

**Table 6. Frequency of sampling for continuous water quality monitoring stations.**

<b>Monitoring Site</b>	<b>Frequency of Sampling</b>	<b>Other Sampling</b>
Portneuf River at Topaz	Monthly, March-Dec.	Spring or event driven runoff
Portneuf River above Marsh Creek	Monthly, March-Dec.	Spring or event driven runoff
Lower Marsh Creek	Monthly, March-Dec.	Spring or event driven runoff
Portneuf River at Edson Fichter	Monthly, March-Dec.	Spring or event driven runoff
Portneuf River at HWY 30 Trail		Spring or event driven runoff
Portneuf River at Batise Rd.	Monthly, Jan.-Dec.	Spring or event driven runoff
WWTF Outfall	Monthly, Jan.-Dec.	Spring or event driven runoff
Portneuf River at Siphon Rd.	Monthly, Jan.-Dec.	Spring or event driven runoff
Bannock Creek *		

\*Proposed station

"Other sampling" refers to additional sampling activities associated with runoff events. Sampling for events has been generalized and may not reflect year-to-year variations in conditions.

Temporal variability is common in stream ecosystems and this is especially true for rivers occurring in arid or semi-arid climates. For example, discharge in the Portneuf River ranges from nearly 500 cfs at high flows to below 50 cfs during base flow (Minshall and Andrews 1973). In addition to seasonal variations, diel changes in dissolved oxygen, pH, and suspended sediments are also common in river ecosystems. Continuous monitoring equipment captures daily, seasonal, and annual changes in several water quality constituents including temperature, dissolved oxygen, pH, specific conductance, and optical turbidity. A combination of traditional sampling and continuous monitoring should adequately characterize water quality and any spatial or temporal variability associated with the constituents of interest.

## **B.2. SAMPLING METHODS**

The project involves standard techniques used to assess water quantity (Nolan and Shields, 2000) and water quality in surface waters (Shelton, 1994). These techniques consist of collection of water samples and data from established ambient monitoring stations with subsequent laboratory analysis.

When sampling problems arise, the sampler is instructed to seek advice from his or her immediate supervisor for guidance in a hierarchical manner. Volunteers will seek the advice of technical staff, which in turn relies on the technical advisors (e.g. senior staff or water quality scientists) for direction. Problems are documented in field notebooks, or on Field Inspection Forms (See Section B10.1). When problems arise in the field during sampling activities, the technical advisor provides oversight and determines whether to continue sampling while providing guidance and implementing corrective actions, or whether to discontinue sampling and contact other members of the PMC and the QA manager. All correspondence involving problems follows this same hierarchical protocol. However, the QA Manager and other members of the PMC are copied on the correspondence to ensure that members of the PMC are kept abreast of problems relevant to the Portneuf River Monitoring Project. Electronic correspondence is encouraged and this provides relevant documentation that can be forwarded to all members of the PMC.

In addition, protocols have been developed to address reoccurring problems. These include topics such as how to record readings when the accumulation of macrophytes on continuous monitoring booms or freezing conditions may affect readings. Both conditions are common. Technical staff has been trained to address these situations independently of a supervisor. In either case, technical staff has been instructed to document conditions on the Field Inspection Forms and use existing protocols that describe corrective actions to be taken.

### **B.2.1 INSTRUMENTATION – CONTINUOUS WATER QUALITY MONITORS AND DISCHARGE**

Water quality is measured continuously at seven Portneuf River monitoring stations using YSI 6-series environmental monitoring systems, including sondes and 650 Multi-parameter Display System (650 MDS) microcomputers. The sonde (French for “probe”) is an electronic device that contains up to five different sensors that measure water quality constituents including temperature, specific conductance, DO, pH, and optical turbidity. The 650 MDS are used for calibration and deployment of sondes (600XL, 6820, and 6920 models; see YSI 6-SERIES Manual for complete descriptions of each model at [www.ysi.com](http://www.ysi.com), manual 069300B) and for field retrieval of logged data.

Each of the seven stations has a Campbell Scientific data logger (CR500 or CR10X) for on-site data storage. Additionally, site telemetry allows data to be transferred at two-hour intervals to a monitoring system computer, which uploads data in raw form to an FTP site where it can be stored indefinitely. The telemetry

system has numerous advantages, including facilitation of review of current performance of monitoring equipment on a daily basis. Malfunctions of probes and sensors can be identified through review of trend charts maintained on the World Wide Web site. In the event of equipment problems with the telemetry system, data can be removed from data loggers using a laptop computer.

River stage is monitored by USGS at three gaging stations located within the Portneuf Basin (see Table 5). In addition, river stage is measured monthly at two PMC sites, Portneuf River at Edson Fichter and Batise Road. River stage will be added to three additional stations (Portneuf Marsh Valley Canal (PMVC), Marsh Creek below Walker Creek, and Portneuf River above Marsh Creek). These PMC stations utilize either stilling wells with floats and shaft encoders, or a pressure transducer (such as that located at the PMVC).

A general systems diagram of a typical continuous quality station is shown in Figure 3. Not all stations include all constituents shown.

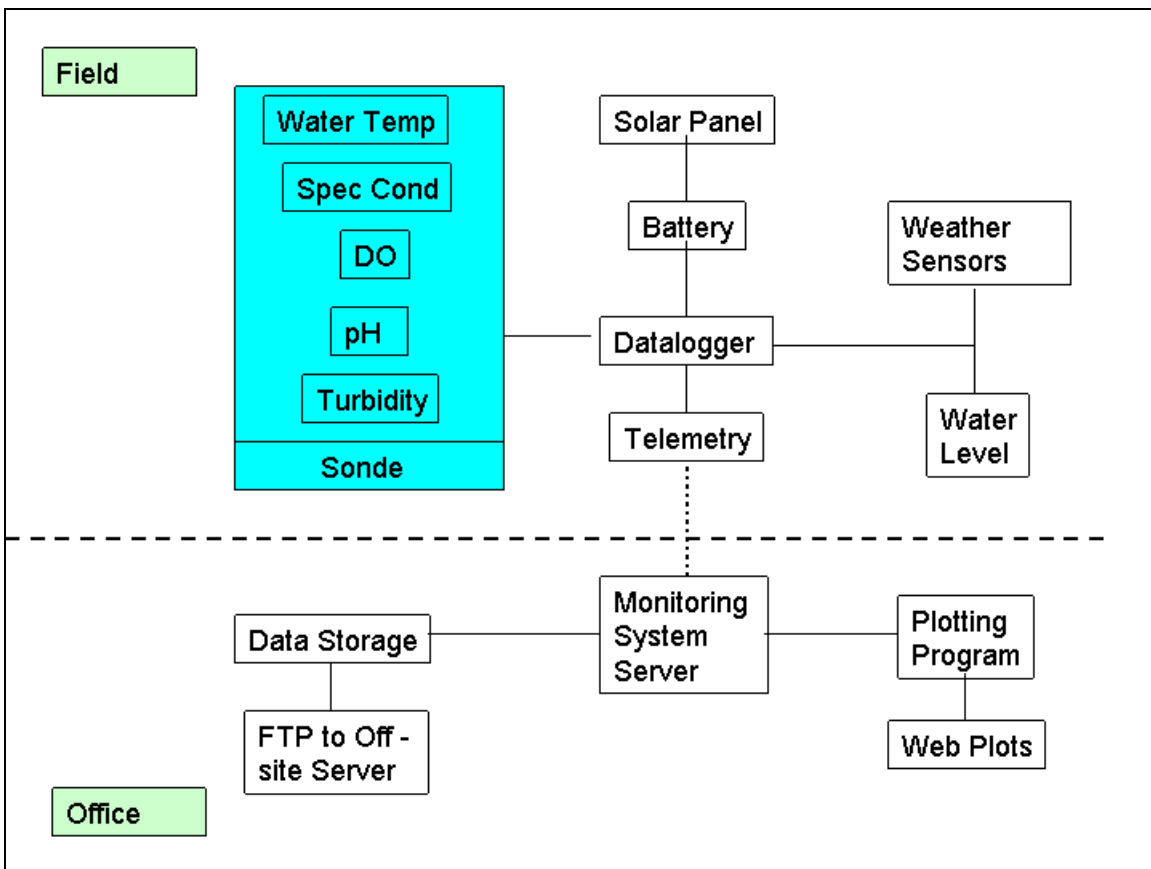

**Figure 3. Systems diagram of continuous quality stations in Portneuf monitoring network.**

## B.2.2 WATER SAMPLING

A regular set of water samples is collected once each month at each monitoring site, with additional samples collected during wet weather/runoff events. This sampling is conducted to provide a basis for estimation of bacterial, nutrient, and sediment loads in the Lower Portneuf River.

Field water quality (e.g., temperature, specific conductivity, DO, pH, and turbidity) is characterized *in situ* using YSI sondes at multiple locations on the cross section (minimum 3), including adjacent to the permanently mounted sonde enclosure during monthly sampling at each station. This profile of field measurements is used as a guide to selecting an adequate number of depth integrated sampling locations for obtaining a representative sample for water chemistry analyses.

Water sampling consists of depth integrated samples collected across the width of the channel. A sample is collected that is representative of the cross sectional chemistry by using six to eight discrete in stream locations at each sampling site. The Equal Width Increment (EWI) method is used for all sampling on the Portneuf. The EWI Method requires equal spacing of a number of verticals across the cross section and an equal transit rate, both upward and downward at all intervals (Shelton 1994).

Samples are collected in wadeable flow conditions using a DH-81 Sampler (Federal Interagency Sedimentation Project, Vicksburg, Mississippi) affixed to a 1 meter wading rod. During high flows, a suspension version (DH-76) of the depth integrated sampler is used. Samples are composited and homogenized in a 14 L polyethylene churn sample splitter. The vertical transit rate is adjusted or a smaller nozzle is used to avoid overflowing the sampler when representing the entire stream depth. Care is taken not to overflow the sample bottle because secondary circulation and enrichment of heavy particles can occur and bias the sample.

Glass Mason jar or Teflon bottles are used with the DH-76 and DH-81 samplers. These bottles and the sample churn are rinsed with deionized water to prevent contamination between subsequent samples. All sample collection and splitting equipment are then triple rinsed with native water prior to sample collection.

From the sample splitter, samples are collected in bottles provided by the laboratory. All bottles must be clearly labeled with a waterproof marker. Minimum information is site identification, date, time, and initials of those taking the samples.

Bacterial samples are collected from a grab sample and introduced directly into a pre-sterilized bottle containing sodium thiosulfate preservative. All samples are

handled and preserved based on laboratory recommendations and following standard water quality sampling procedures (APHA 1998).

Samples for ortho phosphorus analysis are filtered as soon as practicable using a field filtration device, typically a 0.45 µm membrane filter syringe or vacuum filtration apparatus. This filtration is intended to separate soluble from particulate material thereby preserving the sample and arresting microbial activity. Prior to filtration of the sample, the syringe and filter are rinsed initially with deionized water. This filtration step is done either immediately following sample collection or soon thereafter (e.g., within an hour or two). Environmental factors such as subfreezing temperatures or an approaching thunderstorm might prevent immediate filtration in the field. Another factor precluding immediate field filtration, for instance, might be the need to rapidly sample multiple stations during a runoff event.

### **B.2.3 DISCHARGE**

Discharge measurements are made at each of the monitoring stations with the exception of Siphon Road and Topaz, which are covered by the USGS-maintained station for the Portneuf River at Tyhee and Topaz. The Siphon Road Bridge is a poor location for measuring discharge due to back water effects from the impoundment at Tyhee Irrigation Pumping Station. However, it is the lowest downstream location accessible for monitoring before the river enters the Fort Hall Reservation.

Discharge is measured monthly at Batise, Highway 30 Trail, Edson Fichter, Portneuf above Marsh Creek, and Lower Marsh Creek monitoring stations. Discharge measurements are made at uniform stream sections on a permanently placed transect. When excessive growth is observed along the transect macrophytes or algae are removed from the transect and upstream. Prior to discharge measurements at each monitoring station, a measuring tape is stretched perpendicular to the stream flow and used to divide the river into a minimum of 20 increments. This ensures that no more than 5% of the cross sectional area is represented by each velocity measurement. If hydraulic irregularities are observed, additional increments are established to account for noticeable anomalies (Gore 1996).

When wadeable, velocities are measured using an electro-magnetic Marsh McBirney velocity meter affixed to a graduated, stainless-steel, top-set wading rod (Nolan and Shields, 2000). Velocities are measured at a depth of 0.6 times the total depth with the rod resting on the bottom. Measurements are adjusted using the vernier scale converter on the rod. During elevated flows when wading is either unsafe or not possible, measurements are taken using a suspension fish weight, hand winch, and bridge board. When water depths exceed one meter, measurements are taken at 0.2 and 0.8 times the depth, and average velocity is reported. River stage is recorded at the time of depth and velocity

measurements to provide the basis for stage-discharge relationships for each of the aforementioned monitoring stations.

### **B.3. SAMPLE HANDLING AND CUSTODY**

Immediately following collection, water samples are preserved as necessary and placed in ice chests on ice to maintain sample temperature between 0 and 4° C for transport back to the laboratory.

Many chemical constituents may change from the time of sample collection to analysis due to chemical, biological, and physical reactions. Therefore samples for many constituents are stabilized by preservation. Examples of preservation are refrigeration to minimize chemical change by biological activity and addition of acid to minimize transformations and precipitation. Acid is provided by the laboratory in plastic vials that are color coded according to the bottle type. Great care is taken to reduce the possibility of contaminating samples and equipment during the preservation process. Bottles that require no preservation are set aside in the shipping container. Personal protective equipment (e.g., goggles and gloves) is worn when working with acids. Glass containers are placed in padded sleeves to prevent breakage. Chilled bottles are packed in a volume of ice equal to approximately twice the sample volume.

The site name and date of collection are used as a sample identifier. Pertinent data (e.g., station identification, date, time, analyses requested, sample preparation) are entered on Chain of Custody forms. One form is filled out for each group of samples being billed to a particular agency. Table 7 provides information on agencies or entities that are responsible for sample analyses for the various monitoring stations. Example Chain of Custody forms are provided in Appendix B. The chain of custody procedures are intended to ensure that sample integrity is maintained during all phases of sample handling and analysis, and that these procedures are documented with an accurate written record. Chain of Custody forms are completed by technical staff and supervised by the City of Pocatello Laboratory Coordinator.

Samples are generally shipped to the contract laboratory (Energy Laboratories, Inc.) on the same day that they are collected. Samples are shipped under chain of custody in sealed ice chests by overnight courier service. Procedures for receiving, storing, and handling of samples in the laboratory are provided in the respective laboratory's QAPP (City of Pocatello, 2004; Energy Labs, 2004).



**Table 7 Responsibility for laboratory analyses of samples from the Portneuf River Monitoring Project.**

Station	IDEQ	Pocatello WWTF	Pocatello Stormwater	Simplot	Three Rivers RGI Grant
Portneuf at Topaz	•				
Portneuf above Marsh Creek	•				
Lower Marsh Creek					•
Portneuf at Fichter					•
Portneuf Hwy. 30 Trail		•		• <sup>1</sup>	
Portneuf at Batise Rd.		•			
Portneuf at Siphon Rd.		•			
Bannock Creek					• <sup>1</sup>

Notes: 1. Proposed site or responsibility

#### **B.4. ANALYTICAL METHODS**

Constituents are listed in Table 8 and each is followed by the laboratory method of analysis, detection limits, and laboratory conducting the analysis. Energy Laboratories, Incorporated, is located at 1120 South 27th Street, Billings, Montana and the City of Pocatello Water Pollution Control laboratory is located at 10733 North Rio Vista Road, Pocatello, Idaho.

Method detection limits have been evaluated and selected to be consistent with monitoring program objectives. Only standardized laboratory procedures are used in this project. Quality assurance procedures for laboratories are available in their respective quality assurance plans (City of Pocatello, 2004; Energy Laboratories, Inc., 2004). In addition, the laboratory equipment, regulatory citations and instruments needed for the procedures identified in Table 8 are provided in the respective laboratory's QA plan. In the event failures occur, the laboratory coordinator refers to the laboratory's QA plan where appropriate corrective actions are described.

A goal of the PMC is to obtain analytical results from both laboratories (ELI and Pocatello WWTF) within two weeks of sample delivery. This schedule allows sufficient time for re-sampling during the same monthly sampling period in the event that problems arise. Both laboratories have been able to comply with the desired turn around time (approx. 14 days). On average, Pocatello WWTF provides results from their analyses within 72 hours. Results are available in electronic form from ELI within 10 days of sampling. The Portneuf River Monitoring Project's laboratory coordinator is in regular contact with personnel from ELI and in the event of any problems regarding sample storage or sample delivery, re-sampling activities can be initiated within days of the initial sampling.



**Table 8. Laboratory Analyses of Portneuf River samples.**

Analysis	Method	Detection Limit mg/L (except where noted)	Sample Volume (ounces) & Preservative If needed	Sample Holding Time (days)	Laboratoy
Total Alkalinity bicarbonate, carbonate	A2320 B	2	32 <sup>a</sup>	14	ELI
Chloride	E300.0	1	32 <sup>a</sup>	28	ELI
Nitrogen, ammonia	E350.1	0.05	32 <sup>b</sup> ; H <sub>2</sub> SO <sub>4</sub>	28	ELI
Nitrogen, nitrate + nitrite	E353.2	0.05	32 <sup>b</sup> ; H <sub>2</sub> SO <sub>4</sub>	28	ELI
Nitrogen, total Kjeldahl	E351.2	0.05	32 <sup>b</sup> ; H <sub>2</sub> SO <sub>4</sub>	28	ELI
Nitrogen, filter total Kjeldahl	E351.2	0.05	32 <sup>b</sup> ; H <sub>2</sub> SO <sub>4</sub>	28	ELI
Phosphorus, orthophosphorus	E365.2	0.004	8 <sup>e</sup> ; Filter immediately	2	ELI
Phosphorus, total	E365.1	0.004	32 <sup>b</sup> ; H <sub>2</sub> SO <sub>4</sub>	28	ELI
Sulfate	E300.0	1	32 <sup>a</sup>	28	ELI
Solids, total dissolved	A2540 C	10	32 <sup>c</sup>	7	Pocatello WWTF
Solids, total suspended	E160.2	2	32 <sup>c</sup>	7	Pocatello WWTF
Turbidity	A2130; E180.1	0.01 NTU	32 <sup>d</sup>	2	Pocatello WWTF
Fecal coliform	A9222 D	1 count	8 <sup>e</sup>	0.25	Pocatello WWTF
<i>Esherichia coli</i>	A9222 E	1 count	8 <sup>e</sup>	0.25	Pocatello WWTF

A = Standard Methods; E = EPA; ELI =Energy Laboratories, Inc.; WWTF = Wastewater Treatment Facility Lab; Like letters associated with sample volumes indicate that analyses are taken from the same sample container. All sample containers are cooled to 4C. Additional preservative is used where indicated (i.e. H<sub>2</sub>SO<sub>4</sub> to pH<2). Preservation and holding times are taken from 40 CFR Ch. 1 Section 136.3

### **B.5. QUALITY CONTROL**

Obtaining accurate, representative, and defensible analytical data are the main functions of the sampling and analysis program on the Portneuf River. The quality control (QC) program instituted by the PMC can be divided into two components: field and laboratory. Quality of the field data is assessed through routine QC calibration checks of continuous monitoring equipment as well as collection on a regular basis of field QC samples. Laboratory QC samples are analyzed in accordance with the laboratories QA requirements to ensure that analytical results are accurate and defensible.

### **B.5.1 FIELD QUALITY CONTROL**

Quality control samples are collected to document quality of field samples and ensure they are consistent with program objectives. Quality control samples consist of field blanks and replicates.

**Equipment Blanks.** To ensure that equipment used during sampling does not contaminate samples, equipment is filled or pumped with deionized water, transferred to sample bottles, preserved (if appropriate) and analyzed by the lab.

**Field Replicates.** Sample replicates are designed to provide information needed to estimate the precision of results derived from the combination of sample-collection and analytical procedures. Each replicate is an aliquot of native sample water from a splitter and is processed immediately after the primary sample using the same equipment, placed into the same type of bottle, and stored and shipped in the same way. Replicate samples (typically duplicates) will be collected for all parameters at an annual rate of 5% of total samples collected. The duplicate sample results, when combined with laboratory replicates, help to assess the capability of the field crew to implement consistent sampling techniques and procedures.

**Field Blanks.** A field blank is designed to assess potential sample contamination levels that could occur during field sampling and sample processing. Field blanks (deionized water) are taken to the field, transferred to the appropriate container, preserved (if appropriate) and otherwise treated the same as the corresponding sample type during the sampling. Field blanks need only be performed on an as needed basis or during field performance audit. Field blanks will be collected on an annual rate of ~5% of total samples collected. If analysis of field blank reveals concentrations significantly higher than laboratory blanks, the field blank collection frequency will be increased until the source of contamination has been identified.

### **B.5.2 QUALITY CONTROL OF CONTINUOUS MONITORING SYSTEMS**

A variety of procedures are in place to assure the quality of data collected by the continuous monitoring system. These include:

**Time:** Data logger clocks are checked automatically every day and adjusted to be synchronous with the monitoring system server if found to differ by more than 10 seconds.

**Stage Level:** The stage reading of electronic level recorders is checked against manual/visual readings of stage level at the time of manual discharge measurements.

**Sonde Calibration:** A critical part of the PMC's quality assurance program is to ensure that continuous monitoring instruments are providing reliable and accurate measurements of Portneuf River water quality. To ensure that readings generated by data sondes are accurate, both at deployment and retrieval, an independently calibrated sonde is used to compare measurements of the data sonde in the water and only freshly calibrated sondes are deployed for extended periods. If readings from two sondes, both of which must have been calibrated successfully, are consistent (differing by less than 10% for temperature, conductivity, DO, and turbidity or  $\pm 0.2$  pH units for the negative logarithm of the hydronium ion) than the readings can be considered accurate. If any of the parameters exceeds this difference that parameter will be excluded from the dataset to a time when readings were successfully verified using an independent instrument. Rejection criteria for measurements made by the water quality sondes are discussed in Section B.10.3 and D.1.

A goal of the PMC is that sondes will be deployed at all monitoring stations during ice-free periods. Individual sondes are deployed for periods of 7 to 10 days. At the end of a deployment period, the readings from field deployed sondes are subjected to independent verification with a freshly calibrated sonde (i.e. a sonde that has undergone calibration that same day). Consistent readings between the sondes are followed by the retrieval of the resident sonde and deployment of the freshly calibrated sonde. All replacement sondes will have been subjected to laboratory cleaning and calibration prior to any future deployment. One benefit of this type of verification and redeployment is that sondes rotate throughout the monitoring network and the chance that one sonde becomes a permanent resident of any one monitoring station is eliminated. Additionally, these verification and rotation schemes ensure that sonde readings are verified as frequently as sondes are rotated, averaging every seven to ten days.

When inconsistencies are detected between the resident and replacement sonde, the magnitude of discrepancies between readings will be noted. In addition, if diagnostic variables (e.g. DO charge  $< 25$  or  $> 75$ ), indicate the fouling or damage to the sensor, readings taken during that deployment by the sensor in question should be eliminated during the immediate deployment period. In the event of such situations, the recently calibrated sonde can be deployed, but independent verification of readings must be accomplished by comparisons with another freshly calibrated sonde prior to acceptance of the parameter in question. Sondes deployed for longer than 14 days between calibrations will be reviewed carefully and readings be considered reliable only after independent verification from another freshly calibrated sonde.

Probes diverge from calibration for various reasons, including the following:

- aging of the electrode;
- damage or disruption to membranes such as formation of air bubbles;

- fouling of the electrode by accumulated growth of organisms, called biofouling;
- intrinsic drift away from calibration.

A significant amount of time (typically two to four hours, including travel) is required each time a sonde is changed with a freshly calibrated unit. Obviously, a goal of the monitoring program is to collect acceptable data 100% of the time, but it is not economical to recalibrate the sondes more frequently than is necessary. A seven to ten day deployment period has been found to strike an acceptable balance between economy, sonde performance, and data accuracy. If a continuous monitoring site experiences consistent problems with out-of-specification performance, the monitoring technician will shorten the deployment period to investigate the reason for the reduced duration of acceptable performance. In some instances (e.g., rapid fouling conditions due to high biological activity) it may be necessary to recalibrate sensors at least once a week (Wagner et al., 2000). Detailed calibration procedures are described in Appendix B.

### **B.5.3 LABORATORY QUALITY CONTROL**

Procedures for laboratory QC for the two laboratories that support the Portneuf monitoring program are described in detail in their respective Quality Assurance Program documents; see City of Pocatello (2004) and Energy Laboratories Inc. (2004). Laboratory QC samples are prepared and analyzed at the laboratories to assess analytical precision, accuracy, and representativeness. These laboratory QC measures include method blanks, laboratory control samples (also called blank spikes), matrix spikes, matrix spike duplicates, and laboratory duplicate samples. The method blanks provide information on the degree of contamination of field samples that may occur in the laboratory during sample preparation and analysis. Blank spikes and laboratory duplicate analyses enable the laboratory to determine the accuracy and precision of the analytical system. Analysis of matrix spike and matrix spike duplicates are standard laboratory practices for determining the suitability of an analytical method for a particular environmental sample matrix. Laboratory control and duplicate samples are generally analyzed at a frequency of ten percent of total samples submitted for analysis.

### **B.5.4 PROCEDURE FOR EXCEEDANCE OF A QUALITY CONTROL LIMIT - FIELD COMPONENT**

For the field component of the program, exceedances of quality control limits can be separated into stage/discharge monitoring and continuous quality monitoring.

**Stage/Discharge Monitoring** - A control limit exceedance is considered to have occurred if the logged stage measurement differs by more than 0.05 feet from that measured with the mechanical, visual, or electric staff gage. An appropriate corrective response under such circumstances is to document conditions and then determine what factors (e.g., ice effects, siltation, macrophyte growth, loss

of electrical power, etc.) may have caused the discrepancy. With respect to discharge, QC limits may be exceeded if side-by-side evaluation of two velocity flow meters exceeds the manufacturer's specifications for accuracy of the instruments. Once stage vs. discharge relationships are established for a gaging station, this correlation can be used to determine if a discharge measurement is outside the limit of acceptable quality. The manual readings taken monthly at each station's staff gage (less frequently under ice conditions) will be tabulated and compared against stage reading obtained by the automated level recording system. The project data analyst will be responsible for comparing the difference between automated and manual readings, and initiating corrective action if stage readings diverge in excess of 0.05 ft. Corrective action will consist of analysis of the situation by the field technician, along with an appropriate adjustment, if needed, of the level recorder offset in the data logger software.

**Continuous Quality Monitoring** - Acceptance criteria for continuous quality monitoring instruments and procedures to be followed in the event of exceedances of these criteria are provided in Sections B.5.2. Implementing these QC criteria is primarily the responsibility of the project water quality technician, with assistance from the project scientists as needed. Data quality is ensured during the field verification check of *in situ* instrument calibration against a freshly calibrated sonde. If the comparison of the *in situ* and QA sonde exceeds the acceptability criteria on a consistent basis, the protocol involves shortening the period between QA checks of probe calibration. Effectiveness of control actions will be assessed by comparing the proportion of time sondes produce data meeting the quality objectives with the total duration of their deployment.

#### **B.5.5 PROCEDURE FOR EXCEEDANCE OF A QUALITY CONTROL LIMIT - LABORATORY COMPONENT**

Implementation of the laboratory component of the QC program is the responsibility of each laboratory. QC reports or data provided by the laboratories will be reviewed by the data analyst and project scientists for compliance with data quality objectives. Should such evaluation reveal that control limits are exceeded, an inquiry will be initiated to determine the source of the problem.

#### **B.6. INSTRUMENT / EQUIPMENT TESTING, INSPECTION, AND MAINTENANCE**

Stations were designed to require minimal maintenance. However, regular inspections are required for probe and staging calibration, and to ensure that stations function as intended. Examples of station maintenance are provided below. Spare sondes and probes, and discharge equipment are available for use at both City of Pocatello WWTF and the Pocatello Regional Office of IDEQ.

## **B.6.1 SONDE CARE AND MAINTENANCE**

During low flow conditions, macrophytes and filamentous algae can accumulate on the base of the sonde boom and can impact sonde readings. Routine removal of nuisance plant and algal growth is carried out to minimize the effects of non-representative conditions. The degree of bias caused by accumulations of debris on the sonde enclosure is assessed by recording a set of paired readings prior to and following debris removal.

Sondes are removed from the river during prolonged periods of subfreezing daytime temperatures, when ice formation can damage the electrodes. Booms can be removed from the river by employing the swivel attachment (see cover photo), and secured to the support structure (normally a bridge). This prevents accumulation of ice jams that could potentially affect sonde readings.

Because flow conditions associated with thaw events can result in significant transport of suspended material, weather and river stage conditions are monitored closely for timely re-deployment of sondes to capture data during runoff. The Portneuf at Siphon Road station never experiences icing conditions because of the large influence of groundwater. Therefore, continuous quality monitoring throughout the winter is possible and data may be recorded during events when sediment loads can increase.

All data sondes are cleaned regularly following the manufacturer's recommendations. Cleaning is usually initiated after removal of equipment from the river and prior to long-term storage or calibration. The data sonde, and attached sensors, are stored in an upright position, in a calibration cup containing tap water. This precautionary storage measure prevents drying and damage to the DO and pH sensors. Spare and unused sensors are stored individually following manufacturer's recommendations (See Section 2.10.4 of YSI Environmental Monitoring Systems Manual).

Software settings for all instruments are checked to verify that they are consistent among sites. Exceptions for variations from these settings must be documented and accompanied by an explanation for the deviation. For example, settings affecting the way the turbidity sensors acquire data include data filter enabling, time constant, and threshold levels. Uniformity among data sondes eliminates variations in readings that may be a response to any or all of the above settings.

As noted in Table 2, the monitoring technician is responsible for testing, inspection and maintenance of sondes. In the event of malfunction, equipment is returned to the manufacturer for repair or calibration.



## **B.6.2 GAGING STATION LEVEL**

The monitoring technician is also responsible for testing, inspection and maintenance of discharge equipment. Accuracy of velocity meters are verified quarterly by technical staff. Readings are verified using multiple flow meters and taking concurrent measurements under a range of flow conditions. In the event of malfunction, equipment is returned to the manufacturer for repair or calibration.

Gaging station level monitoring equipment consists of manually-read staff gages and automated level monitoring equipment, either shaft encoder or pressure transducer. Maintenance of porcelain enamel staff gages involves periodic inspection for possible damage and brushing, if needed, to remove accumulations that may obscure the marked gradations. Electric tape gages are maintained by ensuring sufficient charge of the 12 volt battery that powers the device. All level monitoring equipment selected for use on the Portneuf River monitoring project features a serial digital output (SDI) , which minimizes the need to correct for errors related to data transmission between the instrument and the data logger/telemetry system. The primary maintenance associated with the stilling well - shaft encoder system is ensuring free passage of water from the channel to the stilling well. The connecting pipes between channel and stilling well, if present, shall be inspected on a monthly basis to ensure that they are not clogged by sediment or debris. Concurrent with discharge measurements, the technician will read the stage level to allow comparison with automated level recorder.

## **B.7. INSTRUMENT/EQUIPMENT CALIBRATION AND FREQUENCY**

All sondes are cleaned prior to calibration. Calibrations are completed following manufacturer's recommendations and are carried out in the laboratory. A detailed description of the calibration procedures is outlined in Appendix C. Diagnostic information and pre- and post-calibration readings are recorded on the Calibration Worksheet; the worksheet is contained in Appendix D. The calibration worksheet acts as a record of all calibrations and these sheets are stored in calibration folders and archived at the City of Pocatello's WWTF. Appendix E provides a list of the calibrants used during routine calibrations and their associated vendors.

All sondes are calibrated prior to deployment. Since individual sondes are deployed for periods of 7 to 10 days, it is likely that laboratory calibration of all sondes will occur at a similar frequency (see B10.3. Instrument Acceptance Criteria for details). If technical problems are encountered during calibration appropriate comments are recorded on the Calibration Worksheet. It is often necessary to field calibrate the DO sensor due to issues of temperature stability between the laboratory and monitoring stations where DO readings are being acquired (see Section 5.8 in the YSI Environmental Monitoring Systems Manual for a full discussion). Field calibrations follow the same recommendations and



procedures used in the lab and are performed when the sensor's diagnostic parameters indicate that the sensor is in a reliable condition (i.e., DO charge in the range 25 - 75).

When diagnostic parameters reflect problems with a sensor, these conditions are recorded and monitored during future calibrations. Sustained violations (beyond two calibrations) of the optimum function ranges for pH, DO, or conductivity sensors indicate the need for further maintenance or the replacement of the sensor in question. Optimal ranges for each probe are described on the Calibration Worksheet.

Barometric pressure for DO probe calibration is determined using the barometer that is built into the YSI 650 MDS. The PMC has provided a pool of several of these instruments. On a monthly basis the technician will cross check barometers on all the 650s to be sure they are reading within manufacturer's specifications. On an annual basis, the 650s will be taken to the National Weather Bureau station at the Pocatello Airport for a calibration check.

#### **B.8. INSPECTION / ACCEPTANCE OF SUPPLIES AND CONSUMABLES**

A logbook is maintained with date of receipt and lot number, when applicable, for supplies such as pH buffers, calibration standards, and electrode maintenance kits. The primary concern on the Portneuf Monitoring Project is that calibration buffers and standards are used within their viable periods (i.e., prior to expiration dates).

Consumables critical to the regular calibration of continuous monitoring sondes are provided in Appendix E. The Portneuf River Monitoring Project laboratory coordinator checks all standards upon delivery. The lot number and expiration dates are kept on record at the Pocatello WWTF. Consumables are stored as specified by the manufacturer. Care is taken that consumables are used prior to the manufacturer's designated expiration date.

#### **B.9. NON-DIRECT MEASUREMENTS**

Non-direct measurements include data used for project implementation that are obtained from measurement sources outside the monitoring program, such as computer data bases, literature sources and historical data bases. The primary non-direct measurements for this project are discharge data collected by the USGS. The distinction between provisional and published USGS river discharge data is critical, and where possible project implementation will be based on published results, which are those that have been reviewed for accuracy and have had final stage discharge rating curves applied.

Other non-direct measurements are not major elements to this project. Therefore, key resources, support facilities, limits to validity and operating conditions are not described herein.

## **B.10. DATA MANAGEMENT**

A successful continuous monitoring program requires that detailed field notes and instrument logs are maintained (USGS 2000). A detailed description of record-keeping and data storage and retrieval requirements is provided below. The QA Manager is responsible for ensuring that the data management scheme is executed as planned.

### **B.10.1 FIELD NOTES**

An essential part of quality assurance is the documentation of all field activities; records of field work facilitate decisions made during the data processing and evaluation phases. Documentation of field conditions is required during sonde deployment, removal, and routine maintenance of monitoring stations. A detailed description of field notes is provided below.

1. Documentation of pre- and post-deployment readings from all sensors provides necessary information for evaluation of instrumentation acceptance, and provides documentation regarding the consistency of readings between data sondes deployed in tandem.
2. Documentation of field calibrations, necessary for accurate measurement of DO assist in the acceptance and application of corrections to DO measurements from deployed sondes.
3. Documentation of the removal of debris, including plants, algae, woody material, fish, and aquatic invertebrates and their casings must be noted. These materials are known to affect sensor readings and removal of such material must be properly noted for data evaluation purposes.
4. Documentation of field conditions (e.g. rain, snow, darkness) assists in interpreting anomalous measurements that may be accounted for due to environmental conditions associated with the time of data entry.
5. Description of depth-integrated sampling at each site, including number of vertical replicates and the number of cross-sections sampled.

This list should not be considered comprehensive, but sets our minimum expectation of note collection for all field activities.

A field site inspection form is completed to provide documentation of each visit made to a continuous monitoring station (see Figure 4). The form is printed on durable water resistant paper and completed sheets are scanned into computer files on a weekly basis.

Portneuf River Monitoring Project Field Site Inspection Form				
Site Name: _____		Site Location: _____		
Date: _____		Arrival Time: _____		
Technician: _____		Departure Time: _____		
Sensor Readings				
In situ Unit: _____		Replacement Unit: _____		
Time: _____		Time: _____		
In situ Sonde	Weeds: Heavy Medium Light None			New Sonde
Sensor	Before Reading	After Reading	Probe Condition	Reading
C°				
MS/c m				
DO%				
DO mg/L				
DO Chg				
PH				
NTU				
Weather:		Clear Partly Cloudy Light Medium Heavy Snow Rain Calm		
Barometer/ mmHg:		Light Breeze Gusty Winds Very Cold Warm Hot		
_____		Snow on Ground No Yes: _____ in.		
People	Dogs	Cows	Wildlife	Horses Debris _____
Notes:				

**Figure 4. Field Site Inspection Form**

**B.10.2 INSTRUMENT LOG**

A log of all activities associated with instrument calibration and maintenance is maintained at the City of Pocatello WWTF laboratory. This log provides a history of calibrations, sensor changes, and repairs for each instrument used in the acquisition of water quality information for the Portneuf River.

**B.10.3 WATER QUALITY DATA HANDLING PROCEDURES**

Evaluation of raw data files is necessary to ensure that transfer of raw instrument readings to a form for public display occurs in a manner that is scientifically

defensible. Our goal is to perform rigorous evaluation of raw data files and eliminate erroneous or unreliable information from our datasets.

The data management scheme for Portneuf River water chemistry results is depicted in Figure 5. Field and laboratory data are entered into a database, which is maintained on an Excel spreadsheet. Data entry is validated by comparing the spreadsheet entries against the original data sheets. A set of trend plots is then updated and checked for outliers. The updated data file is then posted on the project web site. On an annual basis, data are reviewed and approved for publication, which includes release to a national data base such as STORET.

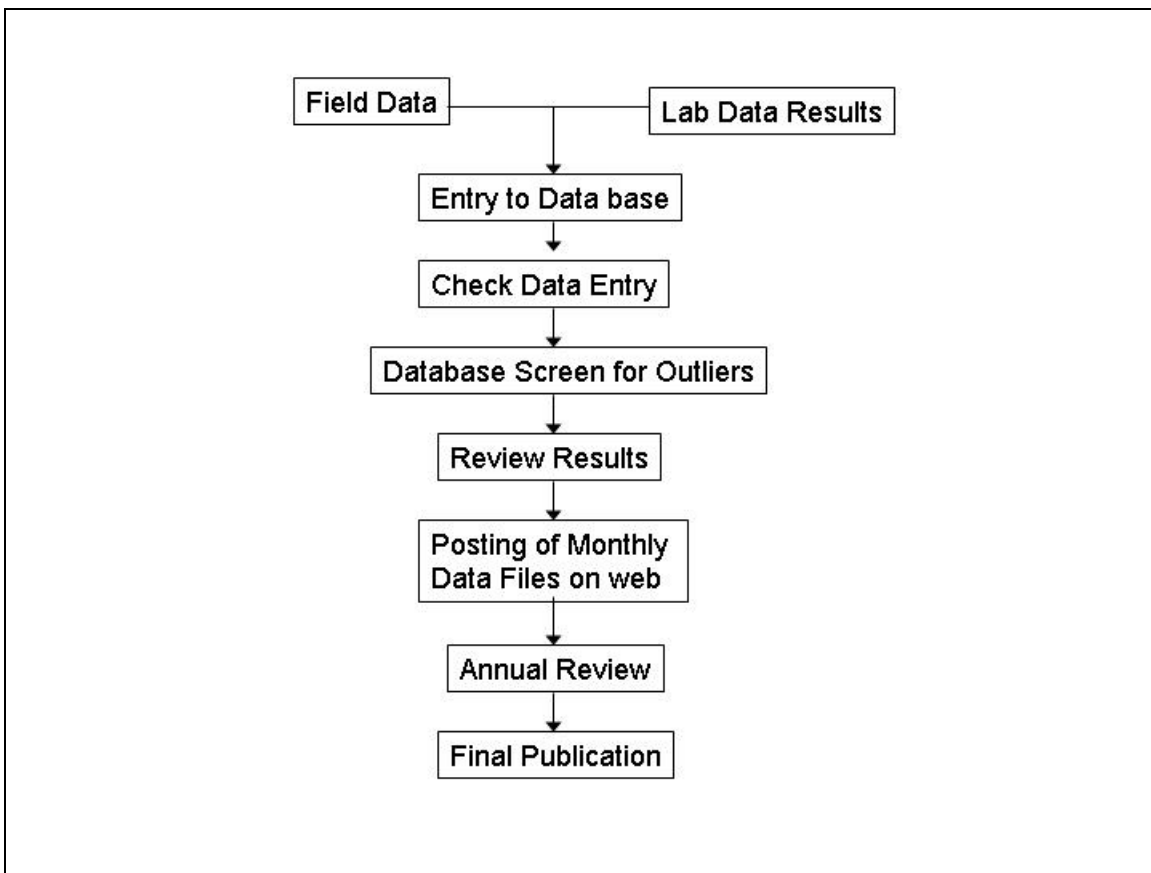

**Figure 5. QA review and data management procedure for water chemistry data**

The data management scheme for Portneuf River continuous water quality results is depicted in Figure 6. Constituents monitored at stations are plotted on trend plots maintained on the project web site; these plots are updated automatically every two hours. The river monitoring technician reviews these trend plots on a daily (5 days per week) basis as part of the routine maintenance check of the stations.

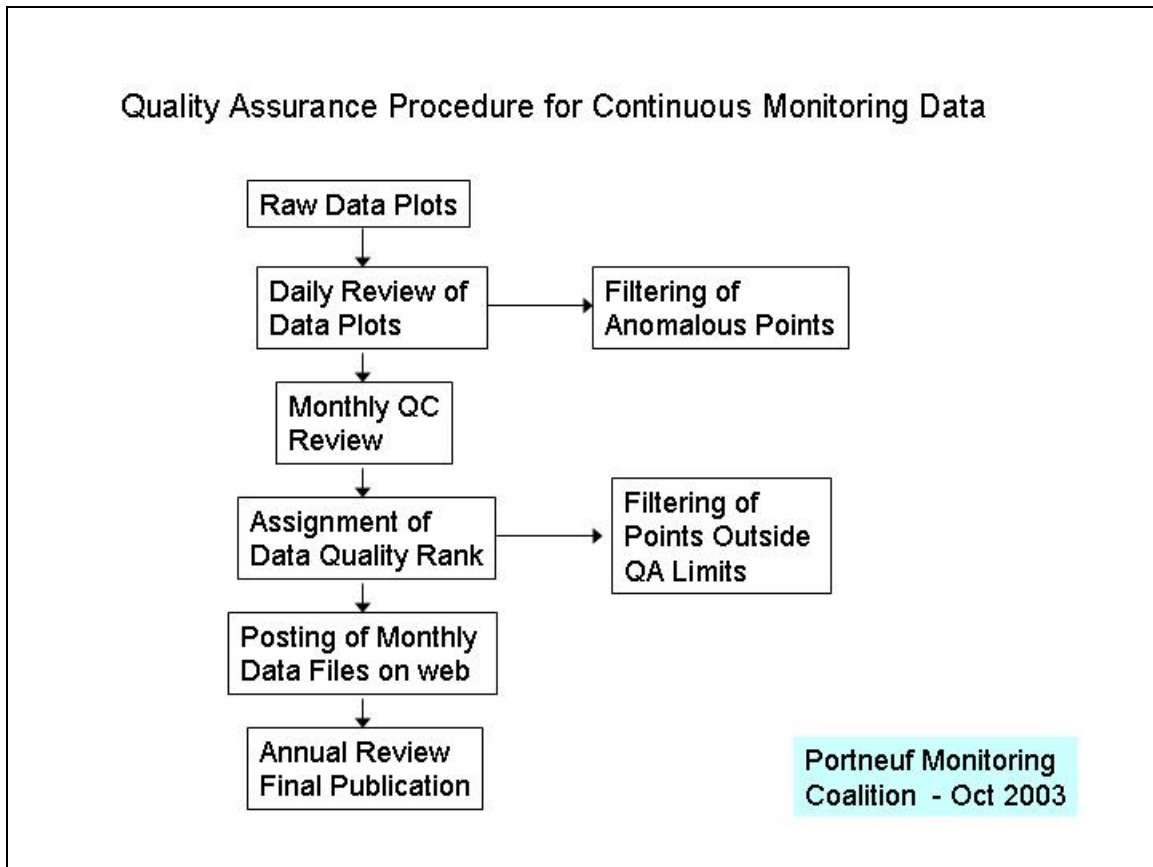

**Figure 6. Quality assurance procedure for continuous monitoring data**

An example of the file produced by the data loggers is given in Table 9. The shaded portion of the plot represents the QA entry fields for each measured constituent. These QA entry fields provide a means to grade the characteristics of the constituents in each record. Table 10 shows the data grading procedure for data from the continuous monitoring sondes.

**Table 9. Example data file produced from the Portneuf monitoring station network.**

The shaded portion on the right side of the file represents the QA coding produced by the data logger.

Stat ID	Year	Day	HrMin	Batt_Volt	Temp C	Spec Cond	DO %Sat	DO mg/L	Do chg	pH	Turb NTU	Dec Day	QA_Tem	QA_SPC	QA_DO	QA_pH	QA_Turb	QA_SH
45	2003	73	510	13.09	10.27	0.71	85.7	9.59	50.2	8.32	31.6	0.215	0	0	0	0	0	0
45	2003	73	520	13.09	10.27	0.708	86.3	9.66	49.2	8.32	33	0.222	0	0	0	0	0	0
45	2003	73	530	13.09	10.27	0.708	85.7	9.59	50.2	8.31	34.4	0.229	0	0	0	0	0	0
45	2003	73	540	13.08	10.27	0.708	85.4	9.56	49.2	8.32	36.1	0.236	0	0	0	0	0	0
45	2003	73	550	13.08	10.27	0.707	85.3	9.54	50.2	8.32	39.2	0.243	0	0	0	0	0	0
45	2003	73	600	13.08	10.26	0.706	85	9.51	49.2	8.32	42.6	0.25	0	0	0	0	0	0
45	2003	73	610	12.99	10.26	0.705	84.9	9.5	50.2	8.32	49.1	0.257	0	0	0	0	0	0
45	2003	73	620	12.87	10.25	0.704	85.4	9.56	49.2	8.32	54.3	0.264	0	0	0	0	0	0
45	2003	73	630	13	10.25	0.704	84.8	9.49	49.2	8.31	62	0.271	0	0	0	0	0	0
45	2003	73	640	13.03	10.24	0.703	85	9.52	50.2	8.32	71.6	0.278	0	0	0	0	0	0
45	2003	73	650	13.04	10.23	0.702	85.6	9.59	49.2	8.31	80.4	0.285	0	0	0	0	0	0
45	2003	73	700	13.05	10.22	0.701	85.5	9.59	49.2	8.31	88.8	0.292	0	0	0	0	0	0
45	2003	73	710	13.05	10.21	0.7	85.2	9.55	49.2	8.31	101	0.299	0	0	0	0	0	0
45	2003	73	720	13.05	10.2	0.7	85.2	9.55	49.2	8.3	103.9	0.306	0	0	0	0	0	0
45	2003	73	730	13.06	10.19	0.699	85.7	9.61	49.2	8.3	115.2	0.313	0	0	0	0	0	0
45	2003	73	740	13.07	10.18	0.698	85.1	9.54	49.2	8.31	117	0.319	0	0	0	0	0	0
45	2003	73	750	13.12	10.17	0.698	84.9	9.52	49.2	8.3	113.3	0.326	0	0	0	0	0	0

**Table 10. Data grading procedure for continuous monitoring data.**

<b>Data QA Grade</b>	<b>Description</b>
0	Default entered by data logger
1	Excellent
2	Good
3	Fair
4	Poor
5	Rejected – outside of tolerance limits
9	No sensor –

### **C. ASSESSMENT AND OVERSIGHT**

The network of continuous monitors and monthly field sampling is providing necessary background information on the quality of water in the Portneuf River. These data will assist in the implementation and refinement of the Portneuf River TMDL. The availability of such data, which can be accessed at [WWW.PORTNEUFIVER.ORG](http://WWW.PORTNEUFIVER.ORG) or from one of the PMC partners, has resulted in a renewed interest in the Portneuf River and its water quality. Collaborations between scientists representing agencies, universities, and tribes have been established since the implementation of this project and these parties will benefit from the successful accumulation of information collected using this original network of continuous monitors.

#### **C.1. ASSESSMENT AND RESPONSE ACTIONS**

Assessment activities are critical to the successful implementation of the quality assurance program. The following table describes the assessment activities for the Portneuf River Monitoring QAPP including frequency, responsible individual, and additional participants.



<b>Activity</b>	<b>Frequency</b>	<b>Responsible Individual</b>	<b>Additional Participants</b>	<b>Authority to Issue Stop Work Orders</b>
Review Quality Assurance Project Plan	Annual	QA Manager	Data Analyst Technical Editor Project Scientists Project Manager Stakeholders	n/a
Self Assessment of Compliance with QAPP	Annual	QA Manager	Project Scientists, Project Manager Stakeholders	n/a
External Quality Assurance Audit	Once every 3 years	QA Manager	Project Scientists Project Manager Stakeholders External Agency	n/a

The basic process for producing QAPP Annual Assessment reports will consist of the following:

1. Conduct planning meeting to discuss changed needs or developments since last assessment report (April of each year).
2. Contributors are assigned assessment tasks.
3. Conduct assessment and draft individual sections.
4. Compile into draft report.
5. Team reviews draft report.
6. Report circulated for review.
7. Final report completed (July of each year).

The reports will be made available to all interested stakeholders and posted on the project web site.

Corrective actions identified in the report will be discussed by the Technical Advisory Committee of the PMC, with responsibility designated to individuals for corrective action. Corrective actions will depend on the type and severity of the finding. Deficiencies will be addressed by a process involving the following steps:

1. Assign an individual to be responsible for problem investigation and documentation,
2. Clearly identify the problem and when and how it developed,
3. Suggest corrective action to eliminate or reduce the problem,
4. Develop a schedule for implementing corrective action,

5. Assigning an individual responsible for implementing the corrective action,
6. Verify that corrective action has eliminated the problem

The PMC shall correct any deficiencies in the program within three months after they are identified. Corrective action will be described in an addendum to the Annual Self-Assessment Report. Either the Regional Water Quality Manager of IDEQ, or someone designated by the Water Quality Manager, shall be responsible for verifying that this corrective action has been accomplished.

## **C.2. REPORTS TO MANAGEMENT**

The assessment activities described in the preceding section will result in a specific report. An assessment report shall be distributed annually to sponsoring agencies and other interested stakeholders and made available on the project web site. This report will include results of the quality assurance audits conducted once every three years.

## **D. DATA VALIDATION AND USABILITY**

### **D.1. DATA REVIEW, VERIFICATION, AND VALIDATION**

This Section describes the criteria that should be used for accepting, rejecting, or qualifying project data. The EPA Requirements for QA Project Plans (EPA QA/R-5) have specific, rather specialized definitions for the terms verification and validation.

**Verification** concerns the process of examining a result of a given activity to determine conformance to the stated requirements for that activity. It is the process of evaluating the completeness, correctness, and conformance of a data set against the method, procedural, or contractual specifications.

**Validation** concerns the process of examining whether a specific requirement such as quality of data is being fulfilled. It is an analyte- and sample-specific process that extends the evaluation of data beyond method, procedural, or contractual compliance to determine the analytical quality of a specific data set (EPA, 2002).

The continuous monitoring program has been designed with multiple approaches to identify and eliminate questionable or unacceptable data. A) the regular updating of plots on the web site enables us to scan trends for problems with the probes or other instrument problems or anomalies. B) sondes are regularly checked for calibration and this allows data collected since the last probe calibration to be flagged for possible rejection if the sensor is outside of calibration during the routine check. C) The coding of data files with measures

of quality assurance allows the suspect portions of the data record to be easily flagged and filtered if it is determined to not meet the acceptance criteria. D) Trend plots are created and reviewed prior to data acceptance to aid in the identification of suspect data.

The USGS has established a system of quality rating for continuous water quality records (Table 11). Ratings of continuous monitoring data follow a tiered approach and are described as being excellent, good, fair, or poor. In this system an “excellent” rating is equivalent to the manufacturer’s specifications for calibration of the electrodes (see Table 11). The USGS has established a general procedure in which any data that exceeds the calibration criteria by a factor of ten is rejected as exceeding the “maximum allowable limits” except for DO and turbidity which are more stringent. The manufacturer’s specifications for calibration and the maximum allowable limits for the USGS are compared in Table 12. Table 12 also includes, the maximum allowable limits adopted for the Portneuf Monitoring program, which tend to be more stringent than the USGS’ maximum allowable limits.

**Table 11. Rating continuous water quality records**

(Source: Wagner, et.al. 2000. WRIR 00-4252, Table 9).

Measured physical property	Ratings			
	Excellent	Good	Fair	Poor
Water temperature	$\leq \pm 0.2 \text{ } ^\circ \text{C}$	$> \pm 0.2 \text{ to } 0.5 \text{ } ^\circ \text{C}$	$> \pm 0.5 \text{ to } 0.8 \text{ } ^\circ \text{C}$	$> \pm 0.8 \text{ } ^\circ \text{C}$
Specific Conductance	$\leq \pm 3 \%$	$> \pm 3 \text{ to } 10 \%$	$> \pm 10 \text{ to } 15 \%$	$> \pm 15 \%$
Dissolved oxygen	$\leq \pm 0.3 \text{ mg/L}$	$> \pm 0.3 \text{ to } 0.5 \text{ mg/L}$	$> \pm 0.3 \text{ to } 1.0 \text{ mg/L}$	$> \pm 1.0 \text{ mg/L}$
pH	$\leq \pm 0.2 \text{ unit}$	$> \pm 0.2 \text{ to } 0.5 \text{ units}$	$> \pm 0.5 \text{ to } 0.8 \text{ units}$	$> \pm 0.8 \text{ units}$
Turbidity	$\leq \pm 5 \%$	$> \pm 5 \text{ to } 10 \%$	$> \pm 10 \text{ to } 15 \%$	$> \pm 15\%$

**Table 12. A comparison of manufacturer's specifications, USGS allowable limits, and rejection criteria for data from continuous water quality monitoring sensors.**

Constituent	Manufacturer's Specifications	Maximum Allowable Limits (USGS) <sup>b</sup>	Rejection Criteria for Portneuf River ( <i>under review</i> )
Water temperature	> ± 0.15 ° C	> ± 2.0 ° C	> ± 1.0° C
Specific Conductance	> ± 0.5 %	> ± 30 %	> ± 20%
Dissolved oxygen	> ± 0.2 mg/L or ± 2%, whichever is greater	> ± 2.0 mg/L or ± 20%, whichever is greater	> ± 1.0 mg/L
pH	> ± 0.2 units	> ± 2.0 units	> ± 1.0 units
Turbidity	> ± 5% or 2 NTU whichever is greater	> ± 30%	> ± 20%

Notes: <sup>a</sup> Wagner, et.al. 2000. WRIR 00-4252, Table 8. <sup>b</sup> YSI Incorporated. 6-Series Environmental Monitoring Systems Operations Manual

## DATA REVIEW

All data collected and analyzed in the Portneuf River Monitoring Program will be reviewed to check for errors in transcription, calculation, or input to spreadsheets or computer data bases. Data generated by the cooperators will be subject to the following general validation procedures:

- Data hand-entered into a database or spreadsheet will be verified for accuracy by (1) printing the spreadsheet and proofreading against the original hand entry or by (2) duplicate entry into the database and comparison for accuracy of the dual entries to reveal any differences.
- Electronic calculations will be checked by the technical staff at a frequency sufficient to ensure the accuracy of the calculations. All data reduction algorithms will be verified for accuracy prior to submission.
- Electronically generated data will be reviewed in graphical form to ensure that the data are complete, accurate, and technically reasonable. The removal of outliers, either manually or by computer algorithm, will be reviewed by project senior scientists.
- Analytical results and supporting data will be reviewed to ensure that the data are complete, accurate, and technically sound. A project senior scientist will be responsible for conducting data verification procedures to ensure that published data are accurate, complete, and scientifically reasonable. Missing or suspect data will be explained or identified by data qualifiers given in the database.

## **D.2. VERIFICATION AND VALIDATION METHODS**

The specific review steps are given as follows, grouped by data type:

### ***Continuous Monitoring Data***

- Data are downloaded on a regular basis and trend charts are maintained on the web site.
- Trend charts are reviewed on a daily basis, if possible, to identify instrumentation problems such as probe calibration or fouling.
- Date and time ranges considered anomalous are noted including the reasons why.
- QA codes are entered into the appropriate field of the data file so that known problems and malfunctions are identified.
- Data are considered anomalous when:
  - sensors are obstructed or operational requirements were not met, and therefore equipment was reporting incorrect data
  - data spikes during the exchange of instruments or during a performance evaluation,
  - periods when instruments are known to be out of calibration
- Data are not removed from the primary data set, only screened using appropriate entries in the QA fields.
- Information from field forms and calibration logs is entered.
- A careful graphical review of the data is performed.
- Data that are not acceptable, including data that are noted as anomalous are rejected.
- If possible, adjustments are made for sensor offset or drift based on documented calibration results.
- All modifications and limitations of the data are noted in comment fields.

### ***Water Chemistry Data***

- Results from analytical laboratories, including chain of custody forms, are reviewed for completeness.
- Analytical results are entered to the database either by importing electronic files or hand entry. New entries are checked by proofreading a printed copy against the original hand entry or through a computational comparison.
- Careful graphical review of the data is performed.
- When data appear to be anomalous or outside of expected ranges, possible causes are investigated (e.g., laboratory or database entries, atypical conditions at the time of sampling, etc.).
- Data are rejected only in the event of known sources of contamination.
- Modifications to the data are noted in comment fields.

Project staff will be responsible for conducting data verification procedures to ensure that published data are accurate, complete, and scientifically reasonable. Missing or suspect data will be explained or identified by data qualifiers given in the database. A project senior scientist will approve the data before it is published. All data and reports will be available for data users on the project web site. Table 13 shows the schedule for data evaluation.

**Table 13. Schedule for data evaluation, validation, publication and final archiving of data collected for the Portneuf Monitoring Program**

Item		Target Schedule
		(days after sampling)
<b>Water Chemistry Data</b>		
	Receive results from laboratory	14
	Enter results into data base,	21
	Update trend plots/screen for outliers	28
	Review results	90
	Post quarterly results on web	90
	Annual review	180
<b>Continuous Monitoring Data</b>		
	Review daily trend charts for maintenance needs	1
	Monthly quality control review, assignment of quality ranks	30
	Posting of monthly data files	45
	Annual review	180

Following data evaluation and making of any appropriate corrections, the data are verified and rated for quality. Data that cannot be verified or are rated as unacceptable are not published or distributed; they are however retained and archived.

### **D.3. RECONCILIATION WITH USER REQUIREMENTS**

On an annual basis, project personnel will evaluate the data collection program to assess the extent to which data collected by the monitoring program conform to user needs. The verification and validation process will be documented in an annual monitoring report that will include recommendations for modification of the program. The technical advisory committee for the monitoring program will be responsible for evaluating whether the data requirements are being met.

Project results will be compared against data quality objectives. The technical advisory committee for the monitoring program will be responsible for this evaluation. The committee is also responsible for evaluating the uncertainty of the validated data and how limitations on the data are reported.



## REFERENCES

- APHA 1998. "Standard Methods for Examination of Water and Wastewater." 20<sup>th</sup> ED., American Public Health Association, Washington D.C.
- City of Pocatello. 2004. Laboratory Quality Assurance Plan for City of Pocatello Water Pollution Control Department, City of Pocatello, Idaho.
- Dean, A. and D. Voss. 1999. Design and analysis of experiments. Springer, New York, New York.
- Energy Laboratories, Inc. 2004. Quality Assurance Program for All Facilities Located in Billings, Montana. Revision 2004.03.
- Gore, J. A. 1996. Discharge measurements and streamflow analysis. Pages 53 – 74 *in* F. R. Hauer and G. A. Lamberti, editors. Methods in stream ecology, Academic Press, San Diego, California, USA.
- Idaho Department of Environmental Quality. 2001. Quality management plan. March 15, 2001. Revision No. 0. Boise, Idaho
- Idaho Department of Environmental Quality Technical Services Division, 2004. Evaluation of water quality impacts associated with FMC and Simplot phosphate ore processing facilities, Ground Water Quality Technical Report No. 21, Pocatello, Idaho.
- Minshall, G.W. and D.A. Andrews. 1973. "An ecological investigation of the Portneuf River, Idaho: a semiarid-land stream subjected to pollution. *Freshwater Biology*, 3, 1-30.
- Nolan, K.M., and Shields, R.R. 2000. Measurement of stream discharge by wading: U.S. Geological Survey Water-Resources Investigations Report 00-4036, on CD-ROM.
- Puckett, M. 2002. Quality Assurance Management Plan for the State of California's Surface Water Ambient Monitoring Program ("SWAMP"). California Department of Fish and Game, Monterey, CA. Prepared for the State Water Resources Control Board, Sacramento, CA. 145 pages plus Appendices.
- Shelton, L.R. 1994. Field Guide for Collecting and Processing Stream-Water Samples for the National Water-Quality Assessment Program. U.S Geological Survey Open-File Report 94-455. Sacramento, California.
- U.S. Environmental Protection Agency (EPA). 2001a. U.S. EPA Requirements for Quality Assurance Project Plans. EPA QA/R-5. EPA/240/B-01/003. March.

Wagner, R.J., H.C. Mattraw, G.F. Ritz, and B.A. Smith. 2000. Guidelines and standard procedures for continuous water-quality monitors: site selection , field operation, calibration, record computation, and reporting. U. S. Geological Survey, Water Resource Investigations Report 00-4252. Reston, Virginia.

Yellow Springs Instruments, Inc., YSI Environmental Monitoring Systems Manual.

## APPENDIX A – STATE OF IDAHO SURFACE WATER QUALITY CRITERIA

### 58.01.02.250. SURFACE WATER QUALITY CRITERIA FOR AQUATIC LIFE USE DESIGNATIONS.

**01. General Criteria.** The following criteria apply to all aquatic life use designations. Surface waters are not to vary from the following characteristics due to human activities: (3-15-02)

- a. Hydrogen Ion Concentration (pH) values within the range of six point five (6.5) to nine point zero (9.0); (3-30-01)
- b. The total concentration of dissolved gas not exceeding one hundred and ten percent (110%) of saturation at atmospheric pressure at the point of sample collection; (7-1-93)

**02. Cold Water.** Waters designated for cold water aquatic life are not to vary from the following characteristics due to human activities: (3-15-02)

- a. Dissolved Oxygen Concentrations exceeding six (6) mg/l at all times. In lakes and reservoirs this standard does not apply to: (7-1-93)
  - i. The bottom twenty percent (20%) of water depth in natural lakes and reservoirs where depths are thirty-five (35) meters or less. (7-1-93)
  - ii. The bottom seven (7) meters of water depth in natural lakes and reservoirs where depths are greater than thirty-five (35) meters.
  - iii. Those waters of the hypolimnion in stratified lakes and reservoirs. (7-1-93)
- b. Water temperatures of twenty-two (22) degrees C or less with a maximum daily average of no greater than nineteen (19) degrees C. (8-24-94)
- c. Temperature in lakes shall have no measurable change from natural background conditions. Reservoirs with mean detention times of greater than fifteen (15) days are considered lakes for this purpose. (3-15-02)
- d. Ammonia. The following criteria are not to be exceeded dependent upon the temperature, T (degrees C), and pH of the water body: (3-15-02)
  - i. Acute Criterion (Criterion Maximum Concentration (CMC)). The one (1) hour average concentration of total ammonia nitrogen (in mg N/L) is not to exceed, more than once every three (3) years, the value calculated using the following equation: (3-15-02)
  - ii. Chronic Criterion (Criterion Continuous Concentration (CCC)). (3-15-02)
    - (1) The thirty (30) day average concentration of total ammonia nitrogen (in mg N/L) is not to exceed, more than once every three (3) years, the value calculated using the following equations: (3-15-02)
      - (a) When fish early life stages are likely present: (3-15-02)
      - (b) When fish early life stages are likely absent: (3-15-02)
    - (2) The highest four-day (4) average within the thirty-day (30) period should not exceed two point five (2.5) times the CCC. (3-15-02)
    - (3) Because the Department presumes that many waters in the state may have both spring-spawning and fall-spawning species of fish present, early life stages of fish may be present throughout much of the year. Accordingly, the

Department will apply the CCC for when fish early life stages are present at all times of the year unless: (3-15-02)

(a) Time frames during the year are identified when early life stages are unlikely to be present, and (3-15-02)

(b) The Department is provided all readily available information supporting this finding such as the fish species distributions, spawning periods, nursery periods, and the duration of early life stages found in the water body; and (3-15-02)

(c) The Department determines early life stages are likely absent.

e. Turbidity, below any applicable mixing zone set by the Department, shall not exceed background turbidity by more than fifty (50) NTU instantaneously or more than twenty-five (25) NTU for more than ten (10)

consecutive days(8-24-94)

f. Salmonid spawning: waters designated for salmonid spawning are to exhibit the following characteristics during the spawning period and incubation for the particular species inhabiting those waters: (7-1-93)

i. Dissolved Oxygen. (8-24-94)

(1) Intergravel Dissolved Oxygen. (8-24-94)

(a) One (1) day minimum of not less than five point zero (5.0) mg/l. (8-24-94)

(b) Seven (7) day average mean of not less than six point zero (6.0) mg/l. (8-24-94)

(2) Water-Column Dissolved Oxygen. (8-24-94)

(a) One (1) day minimum of not less than six point zero (6.0) mg/l or ninety percent (90%) of saturation, whichever is greater. (8-24-94)

ii. Water temperatures of thirteen (13) degrees C or less with a maximum daily average no greater than nine (9) degrees C. (8-24-94)

**03. Seasonal Cold Water.** Between the summer solstice and autumn equinox, waters designated for seasonal cold water aquatic life are not to vary from the following characteristics due to human activities. For the period from autumn equinox to summer solstice the cold water criteria will apply: (3-15-02)

a. Dissolved Oxygen Concentrations exceeding six (6) mg/l at all times. In lakes and reservoirs this standard does not apply to: (4-5-00)

i. The bottom twenty percent (20%) of water depth in natural lakes and reservoirs where depths are thirty-five (35) meters or less. (4-5-00)

ii. The bottom seven (7) meters of water depth in natural lakes and reservoirs where depths are greater than thirty-five (35) meters. (4-5-00)

iii. Those waters of the hypolimnion in stratified lakes and reservoirs. (4-5-00)

b. Water temperatures of twenty-six (26) degrees C or less as a daily maximum with a daily average of no greater than twenty-three (23) degrees C. (3-30-01)

c. Temperature in lakes shall have no measurable change from natural background conditions.

Reservoirs with mean detention times of greater than fifteen (15) days are considered lakes for this purpose. (3-15-02)

d. Ammonia. Concentration of ammonia is not to exceed the criteria defined at Subsection 250.02.d. (3-15-02)

## **251. SURFACE WATER QUALITY CRITERIA FOR RECREATION USE DESIGNATIONS.**

**01. Primary Contact Recreation.** Waters designated for primary contact recreation are not to contain E.coli bacteria significant to the public health in concentrations exceeding: (4-5-00)

**a.** For areas within waters designated for primary contact recreation that are additionally specified as public swimming beaches, a single sample of two hundred thirty-five (235) E. coli organisms per one hundred (100) ml. For the purpose of this subsection, “specified public swimming beaches” are considered to be indicated by features such as signs, swimming docks, diving boards, slides, or the like, boater exclusion zones, map legends, collection of a fee for beach use, or any other unambiguous invitation to public swimming. Privately owned swimming docks or the like which are not open to the general public are not included in this definition. (3-15-02)

**b.** For all other waters designated for primary contact recreation, a single sample of four hundred six (406) E.coli organisms per one hundred (100) ml; or (3-15-02)

**c.** A geometric mean of one hundred twenty-six (126) E.coli organisms per one hundred (100) ml based on a minimum of five (5) samples taken every three (3) to five (5) days over a thirty (30) day period. (4-5-00)

**02. Secondary Contact Recreation.** Waters designated for secondary contact recreation are not to contain E.coli bacteria significant to the public health in concentrations exceeding: (4-5-00)

**a.** A single sample of five hundred seventy-six (576) E.coli organisms per one hundred (100) ml; or (4-5-00)

**b.** A geometric mean of one hundred twenty-six (126) E.coli organisms per one hundred (100) ml based on a minimum of five (5) samples taken every three (3) to five (5) days over a thirty (30) day period. (4-5-00)

**APPENDIX B - CHAIN OF CUSTODY FORMS**

THIS INFORMATION WILL BE USED FOR REPORTING/BILLING\* (SEE BELOW)

CHAIN OF CUSTODY RECORD

NAME: Pocatello Water Pollution Control  
 ADDRESS: PO Box 4169  
Pocatello Idaho 83205-4169

ATTENTION: Candice Hurt  
 TELEPHONE/FAX: (208)234-6256 / 237-3927

SAMPLER:

SIGN:

PRINT:

DATE PAGE OF

TESTS TO PERFORM

NO.  
CONTAINERS

OBSERVATIONS, COMMENTS, SPECIAL INSTRUCTIONS

TYPE	SAMPLE ID	DATE	TIME															

1. USE ONE LINE PER SAMPLE
2. INDICATE SAMPLE TYPE (C)COMPOSITE OR (G) GRAB.
3. BE SPECIFIC IN TEST REQUESTS.
4. CHECK OFF TEST TO BE PERFORMED FOR EACH SAMPLE.

RELINQUISHED BY (SIGN AND PRINT)																			
SIGN:					SIGN:														
PRINT:					PRINT:														





# Chain of Custody and Analytical Request Record

PLEASE PRINT, provide as much information as possible.  
Refer to corresponding notes on reverse side.

Company Name:		Project Name, PWS #, Permit #, Etc.:	
Report Address:		Contact Name, Phone, Fax, Email:	
Invoice Address:		Invoice Contact & Phone #:	
Report Required For: <input type="checkbox"/> POT/WW/WTP <input type="checkbox"/> DW <input type="checkbox"/> Other _____		Purchase Order #:	
Special Report Formats - ELL must be notified prior to sample submittal for the following: NELAC <input type="checkbox"/> A2LA <input type="checkbox"/> Level IV <input type="checkbox"/> Other _____		ELI Quote #:	
EDD/EDT <input type="checkbox"/> Format _____		Notify ELI prior to RUSH sample submittal for additional changes and scheduling Comments:	
SAMPLE IDENTIFICATION (Name, Location, Interval, etc.)		Normal Turnaround (TAT)	
Number of Containers Sample Type: A W S V U O All Water Soils/Solids Vegetation Urine Other		RUSH Turnaround (TAT)	
Matrix		Receipt Temp _____ °C Cooler ID(s)	
SEE ATTACHED		Custody Seal Y N Intact Y N Signature Y N Match Y N Lab ID	
1			
2			
3			
4			
5			
6			
7			
8			
9			
10			

Requester by:	Date/Time:	Shipped by:	Received by:	Date/Time:
Requester by:	Date/Time:	Shipped by:	Received by:	Date/Time:

Sample Disposal: \_\_\_\_\_ Return to client: \_\_\_\_\_ Lab Disposal: \_\_\_\_\_  
Visit our web site at [www.energylab.com](http://www.energylab.com) for additional information, downloadable fee schedule, forms, & links.

## APPENDIX C - CALIBRATION PROCEDURES FOR YSI SONDES

Before beginning calibration check to make sure all probes are clean and free of debris. If probes are dirty clean surfaces with brushes provided. Be VERY careful when cleaning around the glass bubble at the end of the pH probe; the brush tip can easily puncture this thin glass membrane.

Check the DO charge. If the charge is less than 25 do not calibrate because the electrodes need reconditioning.

Note: Calibration procedures differ for 6820 (large) and 600 XL (narrow) sondes. The difference comes from the additional probe (turbidity) on the large sonde.

For 6820's check to see that the turbidity wiper parks opposite the emitter and detector slots on the end of the probe in the center of the sonde base.

Finally, for all calibrations never accept an "out of range" value when calibrating a sonde.

.....

Begin calibration:

On the calibration sheet record the date, sonde name, serial number, your name and the time you begin the calibration.

Record the initial DO charge.

Examine the wiper on the turbidity probe, if approximately opposite the slots proceed.

Start calibrating a sonde after connecting the calibration cable by turning on the 650 MDS. Advance in the menu to "calibration". Use calibration cups that are already on the sonde for the calibration process.

Start the calibration with conductivity, followed by a 2-point pH, 2-point turbidity (if using a 6820/6920 or large sonde), and finish by calibrating DO.

Before calibrating, record cal constants for conductivity and DO (DO Gain). These can be read by going to "Advanced" in the sonde menu and then selecting "cal constants". Record the first two constants on the appropriate section of the Calibration Worksheet.

Also report pH mV, a diagnostic tool for the pH probe, by selecting "report" from the sonde menu and then selecting pH mV. (Remember to turn this off after calibration has been completed).

---

## **CALIBRATING CONDUCTIVITY**

Begin calibration with conductivity. Select “SpCond” (specific conductance) from calibration menu.

Set the standard to 1.5 mS/cm.

Pre rinse probe with used calibration standard. Then fill the calibration cup with fresh standard and proceed with calibration.

Allow at least 90 seconds for readings to stabilize then record the temperature, standard, actual reading, and final reading on the calibration sheet.

Push enter to calibrate. Press ESC to return to the calibration menu.

---

## **CALIBRATING PH**

Select “ISE pH” and choose “2 point” calibration.

Start with pH buffer 7.0 (Yellow). Note: pH varies slightly with temperature. Enter the appropriate pH for that temperature (e.g. at 20° C the pH is 7.02). Refer to the table that is provided with the pH buffers.

Pre rinse probe with used calibration standard. Fill the calibration cup with fresh standard and proceed with calibration.

Allow at least 90 seconds for readings to stabilize, then record temperature, standard, actual reading, final reading, and pH mV value on the calibration sheet.

Push enter to calibrate.

A pH buffer of 10 will be used for the second calibration point. Note: pH varies slightly with temperature. Enter the appropriate pH for that temperature (e.g. at 20° C the pH is 10.05).

Pre rinse probe with used calibration standard. Then fill the calibration cup with fresh standard and proceed with calibration.

Allow at least 90 seconds for readings to stabilize, then record the temperature, standard, actual reading, final reading, and pH mV value on the calibration sheet.

Push enter to calibrate.

Press ESC to return to the calibration menu. At this point you may want to return back to the main menu and remove pH mV from the report menu. This is important when calibrating 6820's.

---

### **CALIBRATING TURBIDITY (FOR 6820 SONDES ONLY)**

Select "optical turbidity" and choose "2 point" calibration.

Start with deionized water as the 0.0 turbidity standard.

Pre rinse probe with deionized water. Then fill the calibration cup with fresh deionized water and proceed with calibration.

Allow at least 90 seconds for readings to stabilize, then record the temperature, standard, actual reading, and final reading on the calibration sheet.

Push enter to calibrate.

A turbidity standard of 100.0 will be used for the second calibration point. **Note:** Turbidity standard is very expensive so use this solution sparingly.

Pre rinse probe with used calibration standard. **Pour in only enough standard to fill the bottom reservoir of the calibration cup about ½ way.**

Allow at least 90 seconds for readings to stabilize, then record temperature, standard, and final reading on the calibration sheet.

Push enter to calibrate.

Press ESC to return to the calibration menu.

---

### **CALIBRATING DISSOLVED OXYGEN**

Select "dissolved oxygen" under the calibration menu and choose "DO %".

To prepare the probe for calibration, rinse it with deionized water and loosely attach the calibration cup with a small amount of water in it. It is important that this environment is moist but the probe must not be submersed in water during calibration.

Enter Barometric Pressure (Note this value should automatically enter itself and should be approximately 650 mm Hg (range 600 to 675).

The target “calibrated” DO value should be the B.P. reading entered divided by 760 mm Hg. (Example  $650/760 = 85.5\%$  DO).

Allow approximately 5 minutes for the reading to stabilize and then press enter to calibrate.

Record barometric pressure, temperature, DO actual, DO final, and DO charge.

---

Make note of any problems encountered on the calibration sheet.

Record the time of completion.

If you have problems contact Andy Ray at 233-8662.

**APPENDIX D**

**Calibration Worksheet**

Sonde: \_\_\_\_\_ Serial Number: \_\_\_\_\_

Date: \_\_\_\_\_ Technician: \_\_\_\_\_

Start burn in: \_\_\_\_\_ Start Calibration: \_\_\_\_\_

**DO Charge:** \_\_\_\_\_ **DO membrane changed: Y or N** **Time of Change:** \_\_\_\_\_

**Wiper parks  $\approx 180^\circ$  from optics? Y or N** **Turbidity Wiper Change? Y or N**

**Calibration Component**

	Temp.	Stand.	Actual	After
Sp. Cond.:	_____	_____	_____	_____ <b>Cell Constant:</b> _____ (Range $5.0 \pm 0.45$ )
pH 7:	_____	_____	_____	_____ <b>ph MV:</b> _____ (Range $0 \pm 50$ )
pH 10:	_____	_____	_____	_____ <b>ph MV:</b> _____ (Range $-177$ from pH 7)
<b>Turbidity 0:</b>	_____	_____	_____	_____
<b>Turbidity 100:</b>	_____	_____	_____	_____
DO:	Barometric Pressure: _____ /760 = _____ (%)			
<b>DO Gain:</b>	_____	(Range 0.7 to 1.4)		
<b>DO %:</b>	_____	_____	_____	_____ <b>DO Charge:</b> _____ (Optimal range $50 \pm 25$ )

**NOTES:**

**Accept:** \_\_\_\_\_ **Reject:** \_\_\_\_\_

Time of Completion: \_\_\_\_\_

## APPENDIX E – LIST OF CONSUMABLES AND SUPPLIERS

Consumable	Standard Concentration	Order No.	Vendor and address
Conductivity Standard	1.5 mS/cm	BC 4094	BioPharm, Inc. 187 South Tilley Road, Hatfield AR 71945 800.443.8465
pH buffer	7.00	SB 107-4	Fisher Scientific 3970 John's Creek Ct. Ste. 500, Atlanta, GA 800.766.7000
	10.00	SB 115-4	
Turbidity Standard	123 NTU	607300	YSI, Inc. 1700/1725 Brannum Lane, Yellow Springs, OH 45387 800.765.4974
Turbidity Probe wipers		6027	YSI, Inc. 1700/1725 Brannum Lane, Yellow Springs, OH 45387 800.765.4974
Dissolved Oxygen Probe Service Kit		5775	YSI, Inc. 1700/1725 Brannum Lane, Yellow Springs, OH 45387 800.765.4974



**APPENDIX F – CURRICULUM VITAE OF AUTHORS**

## BIOGRAPHICAL SKETCH

---

### **James T. Brock**

Rapid Creek Research, Inc.  
Tel: (208) 395-0395  
220 East 37<sup>th</sup> Street, Suite C  
Fax: (208) 395-0448  
Boise, Idaho 83714  
Email:jtbrock@rcresearch.com

### ***Professional Preparation***

Zoology	Idaho State University	M.S.	1980
Biology	Amherst College	B.A.	1973

### ***Appointments***

2001- present Associate Research Ecologist, Desert Research Institute (DRI), Division of Hydrologic Sciences, University and Community College System of Nevada

1984- present Instrumentation Research and Development. Design and fabrication of equipment for aquatic studies: instrumentation for measuring suspended material, dissolved oxygen, temperature, benthic metabolism, and groundwater seepage in rivers. Clients include: Idaho State University; Swiss Fed. Institute for Environmental Science & Technology; Stroud Water Research Center; Arizona State University; University of Georgia, Institute of Ecology; Canada's National Hydrology Research Institute; Desert Research Institute; Virginia Institute of Technology.

1983- present Consultant in Aquatic Ecology. Clients include: Tetra Tech for Region IX USEPA, Idaho Dept. of Environmental Quality; S. Florida Water Management District; City of Pocatello, ID; Carollo Engineers for Washoe County Regional Wastewater Reclamation Facilities Master Plan; U.S. Bureau of Reclamation, Carson City, NV; W-E-R AGRA Ltd. for Alberta Environmental Protection, Planning Division, Alberta, Canada; Arizona Game & Fish Dept. for Glen Canyon Environmental Studies, Phoenix AZ; State of Nevada, Environmental Protection Div.; Beak Associates Consulting Ltd, Saskatoon, Saskatchewan for Environment Canada; U.S. EPA, Region IX, San Francisco, CA; ECOS, Inc., Sacramento, CA for U.S. Army Corps of Engineers, Sacramento District;

1984- Research Associate. Giardia and bacterial water quality in a recreational

1985 river drainage: Middle Fork of the Salmon River, Idaho

1978- Research Scientist. Biological, water quality, and aquatic habitat responses

80, 82 of wildfire in the Middle Fork of the Salmon River, Idaho

1977 Research Scientist. R/V Alpha Helix expedition of Amazon River, Brazil and Peru

1976- Research Associate. River Continuum Project. Department of Biology, Idaho

1980 State University. Pocatello, Idaho

### **CLOSELY RELATED PUBLICATIONS**

- Brock, J. T. & Cummins, K. W. 2002. Ecosystem metabolism in the Kissimmee River, South Florida, USA. *Verh. Internat. Verein. Limnol.*, 28(2):680-686.
- Brock, J.T. T.V. Royer, E.B., Snyder, and S.A. Thomas. 1999. Periphyton metabolism: a chamber approach. In: R.H. Webb, J.C. Schmidt, G.R. Marzolf, R.A. Valdez (Eds.), *The Controlled Flood in Grand Canyon*, pp. 217-224. Geophysical Monograph 110; American Geophysical Union.
- Bott, T.L., J.T. Brock, et. al. 1997. An evaluation of techniques for measuring periphyton metabolism in chambers. *Canadian Journal of Fisheries and Aquatic Sciences* 54:715-725.
- Bott, T.L., J.T. Brock, C.S. Dunn, R.J. Naiman, R.W. Ovink, and R.C. Peterson. 1985. Benthic community metabolism in four temperate stream systems: An inter-biome comparison and evaluation of the river continuum concept. *Hydrobiologia*. 123: 3-45.
- Dodds, W.K. and J.T. Brock. 1998. A portable flow chamber for *in situ* determination of benthic metabolism. *Freshwater Biology* 39:49-59.
- Uehlinger, U. and J.T. Brock. 1991. The assessment of river periphyton metabolism: A method and some problems. In: Use of algae for monitoring rivers. Edited by B.A. Whitton, E. Rott, and G. Friedrich. Proceedings of an International Symposium held at the Landesamt fur Wasser und Abfall Nordrhein-Westfalen Dusseldorf, Germany 26-28 May 1991.

### **Other Significant Publications**

- Minshall, G.W. and J.T. Brock. 1991. Anticipated effects of forest fire on Yellowstone stream ecosystems. In: B. Keiter, M. Boyce (Eds.), *Greater Yellowstone's Future: Man and Nature in Conflict?* Yale University Press, New Haven, Connecticut.
- Rushforth, S.R. and J.T. Brock. 1991. Attached diatom communities from the lower Truckee River, summer and fall 1986. *Hydrobiologia* 224:49-64.
- Minshall, G.W., J.T. Brock, and J.D. Varley. 1989. Wildfires and Yellowstone's stream ecosystems. *BioScience* 39:707-715.
- Minshall, G.W., J.T. Brock, and T.W. LaPoint. 1982. Characterization and dynamics of benthic organic matter and invertebrate functional feeding groups in the Upper Salmon River, Idaho. *Int. Rev. ges. Hydrobiologia* 67:793-820.
- Richey, J.E., J.T. Brock, R.J. Naiman, R.C. Wissmar, and J.F. Stallard. 1980. Organic carbon: oxidation and transport in the Amazon River. *Science* 207:1348-1351.

### **Synergistic Activities**

Develops tools to better understand and study aquatic ecosystems. For the past fifteen years, he has led a team of scientists and engineers that have developed a numeric tool (Dynamic Stream Simulation and Assessment Model), which simulates water quality in rivers where periphyton dominates the oxygen and nutrient dynamics.

Develops instrumentation used by research scientists for study of aquatic community metabolism and exchange between ground and surface water.

**Collaborators (excluding those cited in publications list)**

Shawn Benner (Boise State University); Thomas Bott (Stroud Water Research Center); Craig Caupp (Frostburg State University); Kenneth Cummins (Humboldt State University); Steven Krupa (South Florida Water Management District); Gayle Dana (DRI); Christian Fritsen (DRI); Alan McKay (DRI); Rick Susfalk (DRI); Thomas Swan (Truckee Meadows Water Reclamation Facility); John Warwick (DRI).

**Graduate and Postdoctoral Advisors:** Dr. G. Wayne Minshall (M.S. and Ph.D. Advisor)

**ANDREW M. RAY**

*PH.D CANDIDATE, DEPARTMENT OF BIOLOGICAL SCIENCES*

Idaho State University, Box 8007, Pocatello, ID 83209

Phone: 208.282.2272; Fax: 208.282.4570;  
email: rayandr@isu.edu

**PROFESSIONAL PREPARATION**

Ph.D. Biology--*In progress*, Idaho State University, Pocatello, Idaho  
M.S. Biology 1999; Northern Michigan University, Marquette, Michigan.  
B.S. Environmental Science 1994. Purdue University, West Lafayette, Indiana

**APPOINTMENTS**

Outreach and Education Coordinator, Three Rivers RC&D 2003 to present  
River Monitoring Technician, Three Rivers RC&D, 2001 to present  
Graduate Research Assistant, Idaho State University, 1999 to present  
Graduate Teaching Assistant, Northern Michigan University, 1997 - 1999  
USDA Forest Service Volunteer, Hiawatha N. F., Marquette, Michigan, 1998  
Environmental Scientist, Hey & Associates, Inc., Libertyville, Illinois 1996 - 1997  
Wetland Specialist, Environmental Consultants & Planners, DeKalb, Illinois, 1995 - 1996

**PROFESSIONAL SOCIETAL MEMBERSHIPS**

American Ecological Engineering Society, Society for Ecological Restoration,  
Society of Wetland Scientists, Sigma Xi.

**PUBLICATIONS**

Ray, H. L., **A. M. Ray**, and A. J. Rebertus. 2004. Rapid establishment of fish in isolated peatland beaver ponds. *Wetlands 24: In press.*  
Dunham, R., **A. M. Ray**, and R. S. Inouye. 2003. Growth, physiology, and chemistry of mycorrhizal and nonmycorrhizal *Typha latifolia* seedlings. *Wetlands 24:890-896.*  
Kreuzer, M. P., **A. M. Ray**, R. S. Inouye, and H. L. Ray. 2003. The use of data loggers to monitor environmental state changes: snowmelt and loss of surface water. *Bulletin of the Ecological Society of America 84:27-29.*  
**Ray, A. M.**, A. J. Rebertus, and H. L. Ray. 2001. Aquatic macrophyte succession in Minnesota beaver ponds. *Canadian Journal of Botany 79:487-499.*

**MANUSCRIPTS SUBMITTED OR IN PREPARATION**

Inouye, R. S., **A. M. Ray**, J. T. Brock, and L. VanEvery. Diel fluctuations in turbidity: Effects of temperature on sediment load. *In preparation.*  
**Ray, A. M.**, R. A. Donahue, R. S. Inouye, and M. E. Poulson. Using ecophysiological measures as a predictive tool for evaluating interspecific competition in a semi-arid wetland. *In preparation.*

## REPORTS

Inouye, R. and **A. Ray**. 2002. Portneuf River TSS/Turbidity Relationship – Final Report. Submitted to the Idaho Department of Environmental Quality, Pocatello, Idaho.

**Ray, A. M.** 2002. Report on the Lower Portneuf River Monitoring Project Supporting the Portneuf TMDL. Submitted to U. S. Environmental Protection Agency Region 10 Watershed Restoration Unit, Seattle, Washington.

**Ray, A. M.** 2003. Progress Report for the Lower Portneuf River Monitoring Project. Submitted to U. S. Environmental Protection Agency Region 10 Watershed Restoration Unit, Seattle, Washington.

## BOOKS AND MANUALS

Sato, C, J. You, and **A. M. Ray**. 2004. Water and Wastewater Quality: A Laboratory Manual. College of Engineering, Idaho State University, Pocatello, Idaho.

## PRESENTATIONS

Since 1999: 14 presentations at local, regional, national, and international meetings, including:

Inouye, R. S., **A. M. Ray**, J. T. Brock, C. Wilhelm, and G. Mladenka. 2004. Urban influences on water quality in the Portneuf River, Pocatello, Idaho. Utah State University Spring Runoff Conference. Logan, Utah.

**Ray, A. M.** 2003. Temporal changes in arbuscular mycorrhizae infection in *Typha latifolia*: observations from field studies. Pacific Northwest Chapter of the Society of Wetland Scientists and the Society for Ecological Restoration. Portland, Oregon.

L. Van Every, M. Rowe, J. Brock, **A. Ray**, and C. Tanaka. Diel dissolved oxygen: Bringing DO out of the dark. Idaho Department of Environmental Quality 13<sup>th</sup> Annual Nonpoint Source Water Quality Monitoring Results Workshop. Boise, Idaho.

**Ray, A. M.** and R. S. Inouye. 2002. The phenology of vesicular arbuscular mycorrhizal infection in *Typha latifolia*. Society of Wetland Scientists. Lake Placid, New York.

Inouye, R. S., M. E. Watwood, **A. M. Ray**, G. S. Owen. 2001. Vegetation and microbial community development in an agricultural treatment wetland. Batelle Second International Meeting for Wetlands and Bioremediation. Burlington, Vermont.

**Ray, A. M.**, G. S. Owen, J. Harbour, R. S. Inouye and M. E. Watwood. 2001. Litter decomposition in a newly constructed treatment wetland. Society of Wetland Scientists. Chicago, Illinois.

Owen, G. S., **A. M. Ray**, J. Harbour, M. E. Watwood, and R. S. Inouye. 2001. Microbial community characterization in a constructed wetland. Society of Wetland Scientists. Chicago, Illinois.

Ray, H. L., **A. M. Ray**, and A. J. Rebertus. 2001. Fish assemblages of isolated beaver ponds. North American Benthological Society. LaCrosse, Wisconsin

**Ray, A. M.** and A. J. Rebertus. 2000. Macrophyte succession in Minnesota beaver (*Castor canadensis*) ponds. Ecological Society of America, Snowbird, Utah.

### **SCHOLARSHIPS AND AWARDS**

Purdue University Krannert Alumni Scholarship Recipient 1990 and 1991  
Northern Michigan University Excellence in Education Scholarship 1998  
Northern Michigan University Outstanding Graduate Student 1999  
Annie's, Inc. Homegrown Environmental Studies Scholarship Recipient 2002  
Society of Wetland Scientists Student Research Grant Recipient 2002

### **SYNERGISTIC ACTIVITIES**

Presented explanations of wetland treatment systems to municipal water resource managers at annual municipality meetings held in Pocatello, Idaho.  
Assisting Shoshone-Bannock Jr/Sr High School with the development of a teaching and research wetland.  
Assisting Pocatello Community Charter School with plant propagation activities for various native plant projects and participate in annual Science and Engineering Fair activities.

**Lynn R. Van Every**  
Regional Water Quality Manager

Idaho Dept of Environmental Quality  
Pocatello Regional Office  
444 Hospital Way #300  
Pocatello, Idaho 83201  
Phone: 208.236.6160  
Fax: 208.236.6168  
email: [lvanever@deq.state.id.us](mailto:lvanever@deq.state.id.us)

## Professional Preparation

M.S. Biology/Zoology, 1990 - Idaho State University, Pocatello, Idaho  
B.S. Biology, 1988 - Idaho State University, Pocatello, Idaho  
A.A., 1984 – College of Southern Idaho, Twin Falls, Idaho

## Appointments

- Water Quality Regional Manager, Idaho Department of Environmental Quality, Pocatello, Idaho, 1997 – present
- Water Quality Science Officer, Idaho Department of Environmental Quality, Idaho Falls, Idaho, 1996-97
- Environmental Health Specialist, District 6 Health Department, Blackfoot, Idaho, 1990-95
- Teaching Assistant, Department of Biological Sciences, Idaho State University, Pocatello, Idaho, 1988-90
- Research Assistant, Stream Ecology Center, Idaho State University, Pocatello, Idaho, 1987-1989

## Publications

- Kritsky D. C., L. R. Van Every and W. A. Boeger. 1996. Neotropical Monogenoidea. 27. Two new species of Telethecium gen. n. from the nasal cavities of Central Amazonian fishes and a redescription of Kritskyia moravecii Kohn, 1990 (Dactylogyridae, Ancyrocephalinae). Journal of the Helminthological Society of Washington 63:35-41.
- Van Every, L. R. and S.D. Dawson. 1995. Groundwater as a vehicle for disease transmission in southeastern Idaho: A case study. Journal of Environmental Health 58:16-19.
- Robinson C. T., G. W. Minshall and L. R. Van Every. 1993. Seasonal trends and colonization patterns of macroinvertebrate assemblages in two streams with contrasting flow regimes. Great Basin Naturalist 53:321-331.
- Van Every, L. R. and D. C. Kritsky. 1992. Neotropical Monogenoidea. 18. Anacanthorus Mizelle and Price, 1965 (Dactylogyridae, Anacanthorinae) of piranha (Characoidea, Serrasalminae) from the central Amazon, their phylogeny, and aspects of host-parasite coevolution. Journal of the Helminthological Society of Washington 59:25-51.



- Kritsky D. C., W. A. Boeger and L. R. Van Every. 1992. Neotropical Monogeneoidea.17. Anacanthorus Mizelle and Price, 1965 (Dactylogyridae, Anacanthorinae) from characoid fishes of the central Amazon. *Journal of the Helminthological Society of Washington* 59:52-75.
- Inouye, R.S., A. M. Ray, J.T. Brock, and L.R. Van Every. Diel fluctuations in turbidity: Effects of temperature on sediment load. *In preparation*.

### **Selected Presentations**

- Van Every, L. R. and J. Romeis. 2004. Water Quality Impacts from Selenium and other Metals in the Southeastern Idaho Phosphate Mining Resource Area: A Total Maximum Daily Load Perspective. Idaho Geological Society Annual Meeting, Boise, Idaho; 14th Annual Idaho Non-point Source Workshop, Boise, Idaho; American Water Resources Association Annual Meeting, San Diego, California.
- Van Every, L. R., M. Rowe, J. Brock, A. Ray and C. Tanaka. 2003. Diel dissolved oxygen: Bringing DO out of the dark. 13<sup>th</sup> Annual Idaho Non-point Source Workshop, Boise, Idaho.
- Van Every, L. R. and M. Rowe. 2002. Monitoring the Snake River for Turbidity and Suspended Sediment from Drawdown of American Falls Reservoir - 2001. 12<sup>th</sup> Annual Idaho Non-point Source Workshop, Boise, Idaho.
- Rowe, M. and L. R. Van Every. 2002. Comparison of temperatures from data loggers strategically placed in two southeast Idaho streams. 12<sup>th</sup> Annual Idaho Non-point Source Workshop, Boise, Idaho.
- Van Every, L. R., J. Baldwin, J. Brock, M. Rowe and B. Wicherski. 2002. Water quality in the vicinity of phosphate ore processing facilities, Portneuf River, Idaho. 12<sup>th</sup> Annual Idaho Non-point Source Workshop, Boise, Idaho.
- Van Every, L. R. and J. Welhan. 1998. Portneuf Groundwater Forum – What have we learned? Intermountain Conference on the Environment. Idaho Falls, Idaho.
- Van Every, L. R. and S. D. Dawson. 1995. Groundwater as a vehicle for disease transmission in southeastern Idaho: A case study. Ground Water Technical Workshop, Boise, Idaho.
- Van Every, L. R. and D. C. Kritsky. 1993. Coevolution and biogeography of Sciadicliethrum (Dactylogyridae, Ancyrocephalinae) and their ciclid hosts in Central and South America. Second International Symposium on Monogenea, Montpellier, France.
- Van Every, L. R. 1991. Anacanthorus (Monogeneoidea) of piranha from the central Amazon, their phylogeny, and aspects of host-parasite coevolution. Rocky Mountain Conference of Parasitologists, Pingree Park, Colorado.
- Kritsky, D. C. and L. R. Van Every. 1991. The Monogeneoidea: A model for the study of host-parasite coevolution and biogeography in the Neotropics. VonEring Symposium, American Society of Parasitologists Annual Conference, Madison, Wisconsin.

## **Synergistic Activities**

Manage on a daily basis the State of Idaho's water quality program in southeastern Idaho including total maximum daily load plans for the Portneuf, Blackfoot, Bear, and Snake River sub-basins.

Present information on the quality of the regions surface water and provide interpretation of state water quality standards to stakeholder groups, municipalities, industry, state and federal agencies.

Provide guest lectures and participate on panels at Idaho State University and University of Idaho on a periodic basis. Give demonstrations/presentations on water quality and aquatic ecology at local elementary schools. Collaborate with N. Gem High School on an annual monitoring project in the upper Portneuf River.

Chairman of the Black Canyon Monitoring Subcommittee of the Environmental Coordination Committee implementing the federal hydropower license requirements on PacifiCorp's projects in the Bear River.

Active participant in the Bear River Tri-State Water Quality Task Force. Act as principal staff to the Bear River Commissions' Water Quality Committee.