



GENERAL INFORMATION PRODUCT PRICE LIST 2011

PRICES IN EFFECT APRIL 1, 2011

RELEASE 11-1A - April 1, 2011

**General Information: Terms; Return Policy; Contact Info; Freight Zones;
SPQ Form; Design Form; Warranty Summary - Pages G-1 to G-9**

Luminous Heaters (High Intensity): Section 2, Pages L-1 to L-17

Tube Heaters: Section 3, Pages T-1 to T-62

Outdoor & patioSchwank: Section 4, Pages P-1 to P-35

Schwank Group

2 Schwank Way,
Waynesboro, GA 30830

5285 Bradco Blvd
Mississauga, Ontario. L4W 2A6

Orders, Customer Service, Technical Support

1-877-446-3727

Fax: 1-866-361-0523

Design Services

USA Fax: 1-866-361-0523

Canada Fax: 1-866-724-9265

design@schwankgroup.com

Inquiry email: csr@schwankgroup.com

Visit our website for current product information

www.SchwankGroup.com

Select **PUBLISHED INFO** from menu, then Register or Login

As of the effective date, these price sheets supercede all previous price sheets



All Schwank heaters
are certified by
CSA International

General Information: Pages G-1 to G-11

Credit Terms, Sales & Returns Policies G-3

USA Freight Zones & Charges G-4

Canada Freight Zones & Charges G-5

Design Data Form G-6

SPQ (Special Project Quotation) Form G-8

Product Warranty Summary G-9



Credit Terms

When credit is extended by Schwank the terms are: Net 30 days

1% Monthly Interest On Overdue Accounts

Minimum Invoice: A minimum order of \$50.00 is required for invoicing

Schwank Returns Policy

The complete 'Returns Policy' is available from Customer Service, or at www.SchwankGroup.com in the "Published Info" area.

Approval must be issued in advance by Schwank before any returns will be accepted.

All goods being returned must be accompanied by a completed Return Authorization form.

Schwank reserves the right to disallow the return of sold goods.

Warranty Returns

SCHWANK is proud of the quality of the products we distribute through your Organization; Some product components do fail occasionally. If this occurs, the following procedure must be followed:

- 1 Heater MODEL # & SERIAL # are required for any technical services contact
- 2 Contact SCHWANK to be issued a Return Authorization form
- 3 If you wish to return a product for "advance warranty replacement", SCHWANK will send the Return Authorization Form to you along with the advance replacement product(s). This form must be completed and returned to SCHWANK along with the product(s), shipping "Prepaid" - Schwank will refuse "Collect" shipments. At SCHWANK's discretion, SCHWANK may instruct you to field scrap the failed part. In such case, the Return Authorization Form must still be completed and returned to SCHWANK by fax or mail
- 4 Upon receipt of the product and/or the Return Authorization Form, SCHWANK will determine if credit is warranted
 - ✓ if credit is warranted, a credit notice will be issued
 - ✓ if credit is not warranted, an explanation of credit rejection will be sent to you. Unless advised otherwise, the product will be held for 30 days and then scrapped

Restocking Returns

To return an item to Schwank stock for credit against an invoice within 30 days of purchase:

- 1 Contact SCHWANK customer service to be issued a Return Authorization Form
- 2 SCHWANK will forward a Return Authorization Form to you. This form must be completed and returned to SCHWANK along with the product(s), shipping "Prepaid" - "Collect" shipments will be refused. The original invoice number must be indicated on the Return Authorization Form
- 3 Returned items must be in "new condition" and in original packaging / carton
- 4 Upon receipt of the product and the Return Authorization Form, SCHWANK will determine credit amount based upon:
 - a. items returned to Schwank stock are subject to a 25% restocking charge
 - b. damaged items will result in a credit deduction for any repair costs, or no credit value

Charge Backs

Heater must be properly commissioned and the Commissioning Form accurately completed and returned to Schwank. A Commissioning Form is located near the back of the I&O Manual supplied with each heater.

All charge back claims must be approved in writing by Schwank Technical Services prior to commencement of work.

Freight Charges

USA FREIGHT ZONES Page G-5

CANADA FREIGHT ZONES Page G-7



USA FREIGHT ZONES & CHARGES

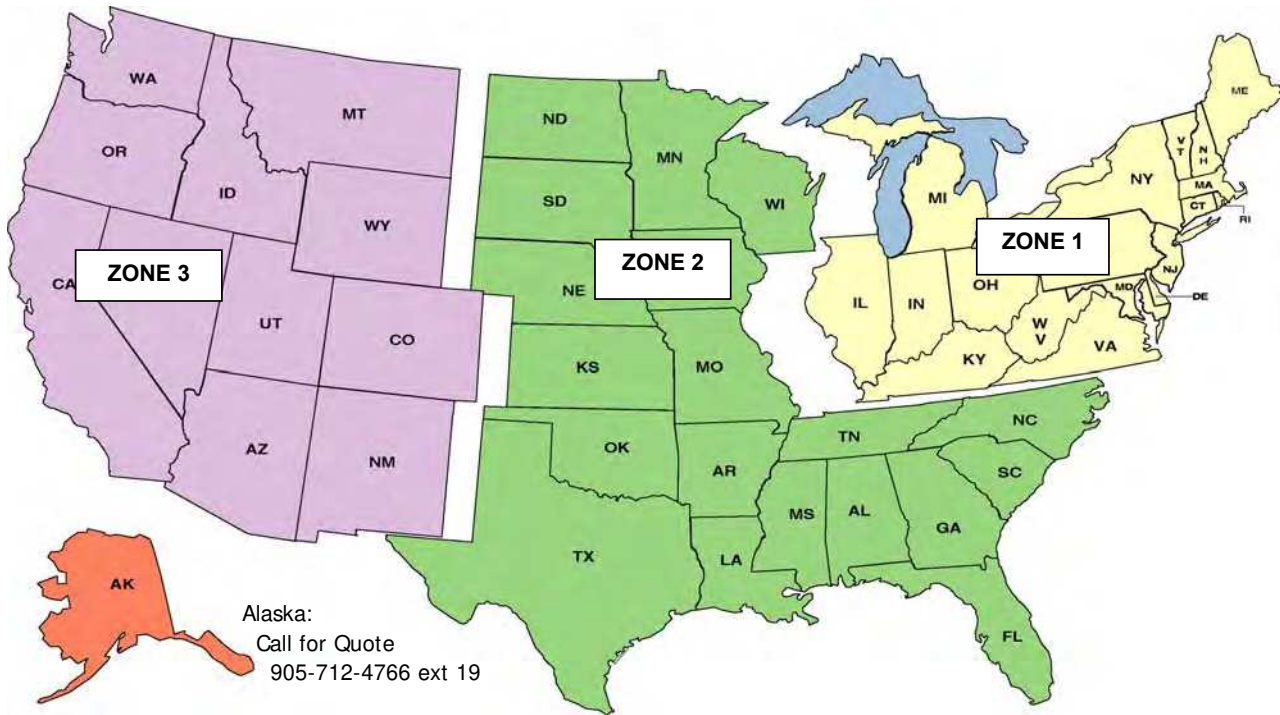

At your request, Schwank will ship any product via your account with any shipper. Please include contact information for your shipper when placing your order.

If you wish to ship "Prepaid & Charge" and have Schwank arrange shipment, please refer to the following freight conditions and charges:

Shipments from our Mississauga facility are subject to the charges listed below. Freight charges are based on current LIST PRICING and single destination shipments within a freight zone. All brokerage charges are included. Freight carrier and routing shall be selected by Schwank. All freight charges will be prepaid and added to your invoice.

<u>Total LIST PRICE (USD)</u>	<u>Zone</u>	<u>Freight Charge Based On LIST PRICE</u>
\$10,000 and OVER	#1	0%
\$5,000 to \$9,999	#1	3%
\$100* to \$4,999.	#1	4%
\$15,000 and OVER	#2	0%
\$7,500 to \$14,999	#2	4%
\$100* to \$7,499.	#2	5%
\$20,000 and OVER	#3	0%
\$10,000 to \$19,999	#3	5%
\$100* to \$9,999.	#3	6%

* Minimum Freight Charges: Transport Truck \$100 ; Parcel Service charges apply to smaller parts orders;
Minimum Order: \$100 LIST; \$50 NET



CANADA FREIGHT ZONES & CHARGES



*GTA: *Brampton, Concord, Etobicoke, Markham, Milton, Mississauga, Oakville, Pickering, Richmond Hill, Scarborough, Toronto, Vaughn, Woodbridge.*

GTA 'Flat Rate' applies to single destination shipment. Additional charges will incur for hand off-loading, delayed off-loading, appointment deliveries, and other special circumstance deliveries.

At your request, Schwank will ship any product via your account with any shipper. Please indicate contact information for your shipper when placing your order.

If you wish to ship "Prepaid & Charge" and have Schwank arrange shipment, please refer to the following freight conditions and charges:

TOTAL LIST PRICE	% ADDER BASED ON LIST PRICE				
	ZONE 4	ZONE 3	ZONE 2	ZONE 1	GTA* (see above)
	FRT	FRT	FRT	FRT	FRT
\$100** to \$2999	15%	12%	10%	7%	\$150.00
\$3000 to \$9,999	10%	9%	8%	5%	\$125.00
\$10,000 to 14,999	7%	6%	6%	3%	\$100.00
\$15,000 to 19,999	5%	4%	4%	2%	0%
\$20,000 to 24,999	3%	3%	2%	0%	0%
\$25,000 to 29,999	2%	2%	0%	0%	0%
\$30,000 and OVER	0%	0%	0%	0%	0%

Freight terms: Shipments from our Mississauga facility are subject to the zone adders above. Zone adders are based on current LIST PRICING and single destination shipments. All freight charges are included, applicable taxes extra. Freight carrier selection and routing shall be the discretion of Schwank. The Freight Adder percentage of LIST PRICE will be prepaid and added to the invoice, applicable taxes extra.

Call for quote for shipment to areas outside of the established Freight Zones.

Off shore locations: Freight costs from a port within the closest Zone are the responsibility of the consignee

** Minimum Freight Charges: Transport Truck \$100 ; Parcel Service Charges apply to smaller parts orders

Minimum Order: \$100 LIST; \$50 NET

This form is also available online in Excel format: www.SchwankGroup.com in the Published Info area

compuSchwank Heat Loss DESIGN DATA

*** INDICATES REQUIRED INFORMATION**

Distributor Name *	Phone *	HEATERS TO USE *
Contact Name at Distributor *	Fax *	Luminous Type:
YOUR COMPANY Name *		supraSchwank <input type="checkbox"/>
Address *		primoSchwank <input type="checkbox"/>
City *		ecoSchwank <input type="checkbox"/>
State / Province *	Zip / Postal Code	Tube Type:
Phone *	Fax *	ultraSchwank -UHE <input type="checkbox"/>
CONTACT Name *		premierSchwank - STS-JZ <input type="checkbox"/>
E-Mail		builderSchwank - S100 <input type="checkbox"/>
PROJECT LOCATION (city) *		Two-Stage - SET <input type="checkbox"/>
PROJECT NAME *		duraSchwank - STW-JZ <input type="checkbox"/>
Degree Days Below 55° F		duraSchwank - SPW-JZ <input type="checkbox"/>
Design Temperature ° F *	Outdoor Temperature*: _____	Let Schwank Recommend <input type="checkbox"/>
	Indoor Temperature*: _____	

Require information for quotation <input checked="" type="radio"/>	Require layout for quotation <input type="radio"/>	Require layout for design / installation <input type="radio"/>
--	--	--

FUEL TYPE *	
Natural Gas <input checked="" type="radio"/>	
Propane <input type="radio"/>	



Floor Plan Sketch	BUILDING PROPERTIES
Please check box on the sketch below to indicate the orientation of the roof ridge (if 'peaked').	
Please check box on the sketch below to indicate the orientation of the roof ridge (if 'peaked').	
<div style="display: flex; justify-content: space-between;"> * Length: <input type="text"/> ft Wall 1 </div> <div style="display: flex; justify-content: space-between; align-items: center;"> <div style="border: 1px solid black; padding: 5px; margin: 5px;"> ROOF TYPE * Flat <input type="radio"/> Peaked <input type="radio"/> </div> <div style="margin: 5px;"> <input type="checkbox"/> Check Warm Wall <input checked="" type="checkbox"/> Check Warm Wall <input type="checkbox"/> Check Warm Wall <input checked="" type="checkbox"/> Check Warm Wall </div> <div style="margin: 5px;"> * Width: <input type="text"/> ft Wall 2 </div> </div> <div style="display: flex; justify-content: center; align-items: center; margin: 5px;"> If 'Peaked - ✓ Ridge Direction: <div style="margin: 0 10px;"> <input type="checkbox"/> or <input type="checkbox"/> </div> </div> <div style="display: flex; justify-content: space-between; align-items: center;"> <div style="margin: 5px;"> * Wid <input type="text"/> ft Wall 5 </div> <div style="margin: 5px;"> Extension (optional) Wall 7 </div> <div style="margin: 5px;"> * Length: <input type="text"/> ft Wall 6 </div> </div> <div style="display: flex; justify-content: space-between; align-items: center; margin-top: 10px;"> <div style="margin: 5px;"> Height of Ceiling Peak / Under Deck* <input type="text"/> ft Roof Height at Eaves (Low Wall)* <input type="text"/> ft </div> </div>	

* Areas marked are minimum data required to proceed with a design.

Please e-mail the completed form to design@schwankgroup.com or fax to: USA 1-866-361-0523; Canada 1-866-724-9265

Material Description	Specify Insulation thickness in inches or 'R' value
WALL MATERIALS *	inches or -> R value
<i>(If wall has different materials, specify the height of each)</i>	inches or -> R value
ROOF MATERIALS *	inches or -> R value

DOORS*	Width	Height	Type	Qty	Door in Wall #	Refer to Wall #'s on Floor Plan Sketch Page 1.
Doors A	ft	ft				
Doors B	ft	ft				
Doors C	ft	ft				
Doors D	ft	ft				
Doors E	ft	ft				

WINDOWS*	Length	Height	Qty	Belongs to Wall	BUILDING CONSTRUCTION*
Windows F	ft	ft			Loose <input type="radio"/>
Windows G	ft	ft			Average <input type="radio"/>
Windows H	ft	ft			Tight <input type="radio"/>

SKYLIGHTS*	Width	Length	Qty	Existing Exhaust Fan Volume*	cfm
Skylight K	ft	ft			
Skylight L	ft	ft		Exhaust Fan operates	min/hr

Incoming Cold Materials*	lbs/hr	Number of Incoming Cars/hr *
Description of Cold Material		Number of Incoming Trucks/hr (please specify the height) *
Specific Heat of Cold Material	BTU/lb	ft High

Fuel Cost Comparison required? Yes (please complete below) No

Enter the cost value in Cents (\$1.25 = 125)

Compare with:	NG	LP	Electrical	#2 Oil
Local Fuel Cost USA	per THERM	per gal.	Cents per kwh	per gal.
(Enter cost in CENTS) CAN	or Cents per m ³	or per liter		or per liter

Compare to: Unit Heaters Furnace Boiler
 Efficiency (refers to above three options) Standard Mid High (Condensing)

Obstructions to locating of heaters (i.e. cranes, inventory, shelving) (please indicate on the sketch)

NOTES & REMARKS:

Date required *	The standard turnaround time is 48 hours, Schwank will try to accommodate earlier requirements
-----------------	--

Areas marked * are minimum data required to proceed with a design.



E-mail completed form: design@schwankgroup.com
 or fax to: USA 1-866-361-0523; Canada 1-866-724-9265
 Additional project sketches or drawings are welcomed

Schwank Group:
 2 Schwank Way
 Waynesboro GA 30830
 5285 Bradco Blvd
 Mississauga ON L4W 2A6

USA and CANADA GENERAL INFO
 APRIL 1, 2011

SP-LGEN-IX-01A
 RD: APR 2011
 RL: 11-1A
 BA



SPECIAL PROJECT QUOTATION

DISTRIBUTOR NAME: _____

COMPETITION: _____

CONTACT: _____

PROJECT CLOSES _____

PHONE NUMBER: _____

SHIPPING DATE: _____

FAX NUMBER: _____

PRICE PROTECTION REQUIRED: _____

ENGINEER _____

COMMENTS: _____

SCHWANK SPEC'D: EQUAL ALTERNATE NOT SPEC'D

JOB NAME: _____

CITY: _____ PROV: _____

QTY	Schwank MODEL NUMBER	COMPETITOR MODEL #	COMPETITIVE PRICE INFORMATION		DISTRIBUTOR PRICE NEEDED
			PRICE TO CONTRACTOR	(GROSS MARGIN EXPECTED)	

FOR INTERNAL USE ONLY

DATE RECEIVED:	QUOTE NO.	FAXED: YES NO
TIME RECEIVED:	CUSTOMER NO.	

- NOTES:**
- Schwank must receive written confirmation of this request from the distributor.
 - Fax this request directly to the National Sales Manager: **USA: 706 554 9390; Canada: 905-712-8336**
 - Requests received without competitive price information will be priced at standard distributor net less Co-op (1%).
 - Requests without distributor, Engineer, job name, etc. will be denied.

REQUESTED BY: _____

ATTENTION: NATIONAL SALES MANAGER



PRODUCT WARRANTY SUMMARY

Effective on all shipments on or after April 1, 2011

Since 1951 Schwank has maintained a reputation of building quality industrial heaters. For this reason, and for our customer's protection, Schwank is prepared to support its heating equipment with the most comprehensive warranties in the industry.

Schwank warrants to the Purchaser that Schwank gas fired infra-red radiant space heaters and all parts, are free from defects in material or workmanship under normal use and service for the following periods of time.

Schwank Product	WARRANTY TERM (YEARS)					
	All Heaters Components	Luminous Ceramic Tile	Tube Heaters		Patio & Portable	
			Burner Cup	Radiating Tubes	Burner	Mantle
LUMINOUS HEATERS: SUPRASCHWANK PRIMOSCHWANK ECOSCHWANK	6 5 2	16 15 10				
TUBE HEATERS: ULTRA STS-JZ STR-JZ STV-JZ STW-JZ(-JZZ) & SPW-JZ S100(J) SET(J)	3 3 3 3 3 2 2		10 10 10 10 10 10 10	10 10 10 10 10 6 6		
PATIO & OUTDOOR HEATERS: 2300 3000 4000 IEP ELECTRIC IR	1 1 1 1	3	10	10	3	3

OPTIONAL ACCESSORIES AND REPLACEMENT PARTS ARE COVERED UNDER THE PART MANUFACTURER'S WARRANTY: TYPICALLY 1 YEAR

Product warranties consist only of providing a like replacement part for a defective part during the term of the warranty, F.O.B. Schwank.

Please note, that the above does not constitute a description of product warranty. This table is intended only as a summary of general warranty term information and is subject to change without notice.

A complete product warranty statement is supplied within each product manual.



LUMINOUS HEATER PRICE LIST 2011



PRICES IN EFFECT APRIL 1, 2011

RELEASE 11-1A

Luminous Heaters (High Intensity): This Section, Pages L-1 to L-18

Other Price List Sections:

General Info: Terms; Return Policy; Contact Info; Freight Zones;
SPQ Form; Design Form; Warranty Summary - Pages G-1 to G-11

Tube Heaters: Section 3, Pages T-1 to T-62

Outdoor & patioSchwank: Section 4, Pages P-1 to P-35

Schwank Group

2 Schwank Way,
Waynesboro, GA 30830

5285 Bradco Blvd
Mississauga, Ontario. L4W 2A6

Orders, Customer Service, Technical Support

1-877-446-3727

Fax: 1-866-361-0523

Design Services

USA Fax: 1-866-361-0523

Canada Fax: 1-866-724-9265

design@schwankgroup.com

Inquiry email: csr@schwankgroup.com



Visit our website for current product information

www.SchwankGroup.com

Select **PUBLISHED INFO** from menu, then Register or Login

These price sheets are the proprietary information of Schwank. This publication, or parts thereof, may not be reproduced in any form or reposted electronically without prior written consent from Schwank. Unauthorized use or distribution is strictly prohibited.



All Schwank heaters
are certified by
CSA International

As of the effective date, these price sheets supercede all previous price sheets.



TABLE OF CONTENTS

SECTION 1		General Introductory: Policies, Freight, Forms	
THIS SECTION 2	LUMINOUS HEATERS	What's New in Luminous Heaters?	L-4
		Luminous Heater & Accessories Selection Guide:	L-5
	World's Best	supraSchwank Ultra Efficiency Combined Intensity Heaters	L-6
		Other Accessories for supraSchwank Ultra Efficiency Heaters.....	L-7
	Next Best	primoSchwank High Efficiency Combined Intensity Heaters	L-8
		Other Accessories for primoSchwank High Efficiency Heaters.....	L-9
	Builder's Best	ecoSchwank Series Luminous Heaters.....	L-10
		ecoSchwank-M Millivolt Series Luminous Heaters.....	L-11
		Other Accessories for ecoSchwank Heaters.....	L-12
	Energy Management & Ancillaries	ThermoControl Plus - IR Heating System Management	L-13
		TruTemp Infra-red Setback Thermostat	L-15
		24V Transformers for ALL Luminous Series Heaters	L-16
		24V Control Guidelines for Luminous Series Heaters	L-16
		Gas Conversion Kits for ALL Luminous Heaters	L-17
Arena Heating Guidelines & Control Panels		L-18	
SECTION 3	TUBE HEATERS	<i>Complete Tube Heater Table of Contents Section 3, Page T-3</i>	
	premierSchwank	STS-JZ Series Positive Pressure Tube Heater Systems	T-6
		STV-JZ Vacuum Series Tube Heater Complete Systems	T-11
	builderSchwank	S100 / S100U Heater & Accessory Selection Chart	T-17
	Two Stage	SET Series Tube Heater Complete Systems & Kit Assembly Chart.....	T-26
	Residential	STR-JZ Workshop/Garage Tube Heater Complete Systems & Accessories.....	T-35
	Car Wash	SPW-JZ Series Outdoor Patio & Carwash Tube Heater Complete Systems ...	T-39
	& Outdoor	STW-JZ Series Carwash Tube Heater Complete Systems	T-42
		STW-JZ2 Burner & Tube Kit Assembly Chart	T-46
	SECTION 4	OTHER HEATERS	ecoSchwank-M Millivolt Series Luminous Heaters.....
STR-JZ Workshop/Garage Tube Heater Complete Systems & Accessories.....			P-13
OUTDOOR & PATIO HEAT		Remote Control & patioPanel ~ Central control of patioSchwank systems	P-14
		patioSchwank 2300 Series Luminous Heaters & Accessories.....	P-15
		patioSchwank 3000 Series* ~ Best under Roof / Canopy or Enclosed Patios	P-16
		Model SPW-JZ Tube Heaters - Powder Coated Cabinet.....	P-17
		Model STW-JZ Tube Heaters - Stainless Steel Cabinet for Coastal Region	P-18
		patioSchwank 4000 Series Portable Parasol Heaters & Accessories.....	P-19
		patioSchwank 4000 Series Fixed Mount Parasol Heaters & Accessories.....	P-20

These price sheets supercede all other price sheets

Schwank reserves the right to make changes in products and pricing without notice.

F.O.B. Mississauga, Ontario
All Applicable Taxes Extra
1% Monthly Interest On Overdue Accounts
Prices subject to change without notice



What's New for 2011?

NEW In this Release 1A - July 1, 2010

Please update your sales information and database

There are no product price changes for 2010.



ThermoControl Plus - page L-13

- *Programmable building management system*
- *True comfort control of IR systems*
- *Payback in less than one heating season*
- *'Smart' adaptive recovery*
- *3 models with up to 8 single or 4 two-stage zone control*

www.SchwankGroup.com - *Get current Published Info for all products*

LUMINOUS HEATER & ACCESSORIES SELECTION GUIDE

Select Heater Series:

24V Power Supply LUMINOUS HEATER SERIES		
supraSchwank		primoSchwank
SUPRA 10 SU-0010-NG / LP		PRIMO 10 MO-0010-NG / LP
SUPRA 15 SU-0015-NG / LP		PRIMO 15 MO-0015-NG / LP
SUPRA 20 SU-0020-NG / LP		PRIMO 20 MO-0020-NG / LP
SUPRA 30 SU-0030-NG / LP		PRIMO 30 MO-0030-NG / LP
SUPRA 40 SU-0040-NG / LP		PRIMO 40 MO-0040-NG / LP
		ecoSchwank
		ECO 6 EC-0021-NG / LP
		ECO 10 EC-0037-NG / LP
		ECO 13 EC-0050-NG / LP
		ECO 18 EC-0075-NG / LP
		ECO 26 EC-0100-NG / LP
		ECO 36 EC-0150-NG / LP
		ECO 52 EC-0200-NG / LP

ITEMS PER ZONE OF HEATERS

COMMON TRANSFORMER/ZONE (120/24VAC) 40VA FOR FIRST HEATER + 20VA / EACH ADDITIONAL		
1 HEATER	40 VA Transformer	JL-0776-XX
UP TO 4	100 VA Transformer	JL-0778-XX
UP TO 6	150 VA Transformer	JL-0779-XX
UP TO 9	200 VA Transformer	JL-0780-XX
UP TO 11	250 VA Transformer	JL-0781-XX
UP TO 16	350 VA Transformer	JL-0781-AA

WALL or ROOF EXHAUST FAN AS REQUIRED

** CANADA AND SOME STATES REQUIRE INTERLOCKED EXHAUST FOR LUMINOUS HEATING SYSTEMS (CHECK LOCAL & NATIONAL CODES)*

USA REQUIRES 4 CFM PER 1,000 BTUH INPUT

CANADA REQUIRES 300 CFM PER 100,000 BTUH INPUT (INTERLOCKED MECHANICAL EXHAUST)

AND
EITHER

LINE VOLTAGE THERMOSTAT
JL-0772-XX
CALL FOR HEAT POWERS:

EXHAUST FAN OR 24V SYSTEM TRANSFORMER DIRECTLY
PROVING SWITCH
24V SYSTEM TRANSFORMER

TruTemp THERMOSTAT
JM-0150-XX
REQUIRES 24 VOLT TRANSFORMER-RELAY JM-0300-XX
TO POWER 24V TruTemp THERMOSTAT:

RELAY POWERS UP 120V EXHAUST FAN OR SYSTEM TRANSFORMER DIRECTLY

24 VOLT THERMOSTAT JS-0569-XX
REQUIRES 24 VOLT TRANSFORMER-RELAY JM-0300-XX
TO POWER 24 VOLT THERMOSTAT:

RELAY POWERS UP 120V EXHAUST FAN OR SYSTEM TRANSFORMER DIRECTLY

AND

50' JACK CHAIN KIT
JL-0798-JC
4 SUSPENSION POINTS per HEATER
= CHAIN REQUIRED FOR EACH HEATER:
4 X DISTANCE BELOW STRUCTURAL FASTENING

S' HOOKS - Pkg of 25
JL-0798-SH
TYPICALLY 8 'S' HOOKS PER HEATER

FLEXIBLE GAS CONNECTOR
Up to 155,000 Btu: 1/2" x 18": JL-0771-FF
Over 155,000 Btu: 3/4" x 24": JL-0771-ZZ



Typical accessories are listed below.
Other accessories: next page
Transformers: page L-16

supraSchwank SERIES

WORLD'S HIGHEST RADIANT FACTOR COMBINED INTENSITY HEATERS

supraSchwank heaters have a radiant output factor of up to 81%

Heaters are shipped complete with gas valve and electronic ignition control.

Optional accessories are listed below, and on the next page

<u>MODEL</u>	<u>CAPACITY</u>	<u>I.R. OUTPUT</u>	<u>GAS</u>	<u>PART #</u>
supraSchwank 10 N/L	29,500 Btuh	22,800	NG	SU-0010-NG
			LP	SU-0010-LP
supraSchwank 15 N/L	44,000 Btuh	34,600	NG	SU-0015-NG
			LP	SU-0015-LP
supraSchwank 20 N/L	59,000 Btuh	46,700	NG	SU-0020-NG
			LP	SU-0020-LP
supraSchwank 30 N/L	88,500 Btuh	71,800	NG	SU-0030-NG
			LP	SU-0030-LP
supraSchwank 40 N/L	118,000 Btuh	95,800	NG	SU-0040-NG
			LP	SU-0040-LP

**Please contact
your local
Schwank
Representative
or Customer
Service for
Project Pricing**

All supraSchwank heaters require 24 volt connection

supraSchwank burners are available for process application - Contact Schwank

OPTIONAL ACCESSORIES FOR supraSchwank

	<u>PART #</u>	<u>LIST PRICE</u>
Flexible Gas Connector 1/2" x 18"	JL-0771-FF	\$ 25.70
Flexible Gas Connector 1/2" x 24"	JL-0771-XX	33.00
#8 Jack Chain - 60 lb work load - box 50'	JL-0798-JC	60.00
#2 Lion Chain - 115 lb work load - 200 ft roll	JL-0800-XX	97.00
'S' Hooks - Package of 25	JL-0798-SH	23.20
Safety Snap Hooks - 2"	JL-0800-SH	40.20
	Package of 24	
	Package of 100	
Angle Mounting Bracket (Pair) (Not for Supra 40)	JO-0331-XX	87.00
Pressure Equalizer Venturi Cover (for Drafty Areas)	JO-0368-XX	160.00
<i>Note: SUPRA 40 Requires <u>Two</u> Venturi Covers</i>		
Control Protector Cover (All Models Except Supra 40)	JO-0366-XX	224.00

THERMOSTATS - For 24V Thermostat control requirements see page L-13

Line Voltage (120V) Thermostat	JL-0772-XX	\$ 39.50
Low Voltage (24V) Digital Thermostat - °F & °C (Requires Transformer/Relay JM-0300-XX below)	JS-0569-WR	66.00
TruTemp Set Back Infra-red Thermostat (24V) (Requires Transformer/Relay JM-0300-XX below)	JM-0150-XX	213.00
Transformer/Relay (Required for TruTemp or 24V Thermostat)	JM-0300-XX	107.00



supraSCHWANK SERIES OTHER ACCESSORIES

Typical accessories: previous page

Transformers: page L-16

EXHAUST SYSTEMS

Schwank no longer offers exhaust fan systems for luminous heaters - these are readily available via local distribution.

Exhaust System Sizing:

- ✓ Luminous heaters are installed unvented
- ✓ Check local & national code requirements
- ✓ National Code Exhaust Volume Requirements (in brief):

☞ **USA:** 4 cfm exhaust per 1,000 Btuh input

☞ **Canada:** 300 cfm interlocked mechanical exhaust per 100,000 Btuh input or any fraction thereof

For all installations, the exhaust or opening for removal of flue products must be located above the level of the heaters.

TILE PROTECTING GRILL: Longer lead times for this accessory

(1" X 1" Rigid Screen)

	<u>PART #</u>	<u>LIST PRICE</u>
For: supraSchwank 10	JU-0355-XX-P	\$ 87.00
supraSchwank 15	JU-0358-XX-P	107.00
supraSchwank 20	JU-0356-XX-P	117.00
supraSchwank 30	JU-0357-XX-P	139.00

CEILING PROTECTION PLATE: Longer lead times for this accessory

For: supraSchwank 10	Uninsulated	JU-0359-UN	\$ 139.00
supraSchwank 15	Uninsulated	JU-0362-UN	170.00
supraSchwank 20	Uninsulated	JU-0360-UN	202.00
supraSchwank 30	Uninsulated	JU-0361-UN	234.00

REFLECTOR EXTENSIONS

For: supraSchwank 10	Single Side	JU-0336-SG	\$ 61.00
	Venturi Side	JU-0339-XX	61.00
supraSchwank 15	Single Side	JU-0342-SG	75.00
	Venturi Side	JU-0342-XX	75.00
supraSchwank 20	Single Side	JU-0337-SG	87.00
	Venturi Side	JU-0340-XX	87.00
supraSchwank 30	Single Side	JU-0338-SG	128.00
	Venturi Side	JU-0341-XX	128.00
supraSchwank 40	Either Side	JU-0340-XX	87.00

PROTECTIVE COVERS - FIT ALL supraSCHWANK MODEL SIZES

Control Protector Cover(Not for supra 40)	JO-0366-XX	\$ 224.00
Pressure Equalizer Venturi Cover(for Drafty Areas) <i>SUPRA 40 Requires <u>Two</u> Venturi Covers</i>	JO-0368-XX	160.00



Typical accessories are listed below
Other accessories: next page
Transformers: page L-16

primoSchwank SERIES

VERY HIGH RADIANT FACTOR COMBINED INTENSITY HEATERS

primoSchwank heaters have a radiant output factor of up to 67%

Heaters are shipped complete with gas valve and electronic ignition control.

Optional accessories are listed below, and on the next page.

<u>MODEL</u>	<u>CAPACITY</u>	<u>I.R. OUTPUT</u>	<u>GAS</u>	<u>PART #</u>
primoSchwank 10 N/L	37,500 Btuh	24,600	NG	MO-0010-NG
			LP	MO-0010-LP
primoSchwank 15 N/L	56,000 Btuh	35,400	NG	MO-0015-NG
			LP	MO-0015-LP
primoSchwank 20 N/L	75,000 Btuh	49,100	NG	MO-0020-NG
			LP	MO-0020-LP
primoSchwank 30 N/L	113,000 Btuh	75,400	NG	MO-0030-NG
			LP	MO-0030-LP
primoSchwank 40 N/L	150,000 Btuh	97,700	NG	MO-0040-NG
			LP	MO-0040-LP

**Please contact
your local
Schwank
Representative
or Customer
Service for
Project Pricing**

All primoSchwank heaters require 24 volt connection

OPTIONAL ACCESSORIES FOR primoSchwank

Flexible Gas Connector 1/2" x 18"

Flexible Gas Connector 1/2" x 24"

#8 Jack Chain - 60 lb work load - box 50'

#2 Lion Chain - 115 lb work load - 200 ft roll

'S' Hooks - Package of 25

Safety Snap Hooks - 2"



Package of 24
Package of 100

Angle Mounting Bracket (Pair) (Not for Primo 40)

Pressure Equalizer Venturi Cover (for Drafty Areas)

Note: PRIMO 40 Requires Two Venturi Covers

Control Protector Cover (All Models Except Primo 40)



<u>PART #</u>	<u>LIST PRICE</u>
JL-0771-FF	\$ 25.70
JL-0771-XX	33.00
JL-0798-JC	60.00
JL-0800-XX	97.00
JL-0798-SH	23.20
JL-0800-SH	40.20
JL-0800-SH-B	123.00
JO-0331-XX	87.00
JO-0368-XX	160.00
JO-0366-XX	224.00

THERMOSTATS - For 24V Thermostat control requirements see page L-13

Line Voltage (120V) Thermostat

Low Voltage (24V) Digital Thermostat - °F & °C
(Requires Transformer/Relay JM-0300-XX below)

TruTemp Set Back Infra-red Thermostat (24V)
(Requires Transformer/Relay JM-0300-XX below)

Transformer/Relay (Required for TruTemp or 24V Thermostat)

primoSchwank SERIES OTHER ACCESSORIES

Typical accessories: previous page

Transformers: page L-16

EXHAUST SYSTEMS

Schwank no longer offers exhaust fan systems for luminous heaters - these are readily available via local distribution.

Exhaust System Sizing:

- ✓ Luminous heaters are installed unvented
- ✓ Check local & national code requirements
- ✓ National Code Exhaust Volume Requirements (in brief):

☞ **USA:** 4 cfm exhaust per 1,000 Btuh input

☞ **Canada:** 300 cfm interlocked mechanical exhaust per 100,000 Btuh input or any fraction thereof

For all installations, the exhaust or opening for removal of flue products must be located above the level of the heaters.

TILE PROTECTING GRILLE: Longer lead times for this accessory (1" X 1" Rigid Screen)

	<u>PART #</u>	<u>LIST PRICE</u>
For: primoSchwank 10	JO-0355-XX-P	\$ 87.00
primoSchwank 15	JO-0358-XX-P	101.00
primoSchwank 20	JO-0356-XX-P	117.00
primoSchwank 30	JO-0357-XX-P	140.00

CEILING PROTECTION PLATE: Longer lead times for this accessory

For: primoSchwank 10 Uninsulated	JO-0359-UN	\$ 160.00
primoSchwank 15 Uninsulated	JO-0362-UN	181.00
primoSchwank 20 Uninsulated	JO-0360-UN	202.00
primoSchwank 30 Uninsulated	JO-0361-UN	234.00

REFLECTOR EXTENSIONS

For: primoSchwank 10	Single Side	JO-0336-SG	\$ 60.00
	Venturi Side	JO-0339-XX	60.00
primoSchwank 15	Single Side	JO-0342-SG	75.00
	Venturi Side	JO-0342-XX	75.00
primoSchwank 20	Single Side	JO-0337-SG	87.00
	Venturi Side	JO-0340-XX	87.00
primoSchwank 30	Single Side	JO-0338-SG	119.00
	Venturi Side	JO-0341-XX	119.00

COVERS FOR ALL primoSCHWANK MODEL SIZES

Control Protector Cover (Not for Primo 40)	JO-0366-XX	\$ 224.00
Pressure Equalizer Venturi Cover (for Drafty Areas) <i>PRIMO 40 Requires <u>Two</u> Venturi Covers</i>	JO-0368-XX	160.00



Millivolt Series: Next page
Typical accessories are listed below.
Other accessories: page L-12
Transformers: page L-16

ecoSchwank SERIES LUMINOUS (High Intensity) HEATERS

ecoSchwank Series heaters include assembled reflectors, gas valve and electronic ignition control. Optional accessories are listed below, and on next page.

<u>MODEL</u>		<u>CAPACITY</u>	<u>GAS</u>	<u>PART #</u>	<u>LIST PRICE</u>
ecoSchwank 6	N or L	21,500 Btuh	NG	EC-0025-NG	\$ 512.00
			LP	EC-0025-LP	512.00
ecoSchwank 10	N or L	35,000 Btuh	NG	EC-0037-NG	533.00
			LP	EC-0037-LP	533.00
ecoSchwank 13	N or L	50,000 Btuh	NG	EC-0050-NG	639.00
			LP	EC-0050-LP	639.00
ecoSchwank 18	N or L	71,500 Btuh	NG	EC-0075-NG	747.00
			LP	EC-0075-LP	747.00
ecoSchwank 26	N or L	100,000 Btuh	NG	EC-0100-NG	804.00
			LP	EC-0100-LP	804.00
ecoSchwank 36	N or L	143,000 Btuh	NG	EC-0150-NG	1,386.00
			LP	EC-0150-LP	1,386.00
ecoSchwank 52	N or L	200,000 Btuh	NG	EC-0200-NG	1,520.00
			LP	EC-0200-LP	1,520.00

All ecoSchwank heaters require 24 volt connection

Also available with millivolt ignition - see Section 4 page P-12

ecoSchwank burners are available for process application - Contact your Schwank representative

OPTIONAL ACCESSORIES FOR ECO SERIES

	<u>PART #</u>	<u>LIST PRICE</u>
Flexible Gas Connector 1/2" x 18" (Up to 155,000 Btuh)	JL-0771-FF	\$ 25.70
Flexible Gas Connector 1/2" x 24" (Up to 155,000 Btuh)	JL-0771-XX	33.00
Flexible Gas Connector 3/4" x 24" - for ECO 52	JL-0771-ZZ	102.00
#8 Jack Chain - 60 lb work load - box 50'	JL-0798-JC	60.00
#2 Lion Chain - 115 lb work load - 200 ft roll	JL-0800-XX	97.00
'S' Hooks - Package of 25	JL-0798-SH	23.20
Safety Snap Hooks - 2"	JL-0800-SH	40.20
	JL-0800-SH-B	123.00
Pressure Equalizer Venturi Cover (for Drafty Areas)	JO-0368-XX	160.00
<i>Note: ECO 36 & 52 Require Two Venturi Covers</i>		

THERMOSTATS - For 24V Thermostat control requirements see page L-13

Line Voltage (120V) Thermostat	JL-0772-XX	\$ 39.50
Low Voltage (24V) Digital Thermostat °F & °C (Requires Transformer/Relay JM-0300-XX Below)	JS-0569-WR	66.00
TruTemp Set Back Infra-red Thermostat (24V) (Requires Transformer/Relay JM-0300-XX Below)	JM-0150-XX	213.00
Transformer/Relay (Required for TruTemp or 24V Thermostat)	JM-0300-XX	107.00



Consult your local & national codes for acceptable application of this millivolt heater

No electrical connection required



Typical accessories are listed below.
Other accessories: next page

ecoSchwank-M Millivolt SERIES LUMINOUS (High Intensity) HEATERS

ECO-M heaters include assembled reflectors, gas valve, millivolt ignition, digital thermostat & 20 ft thermostat wire. Optional accessories are listed below, and on next page.

<u>MODEL</u>		<u>CAPACITY</u>	<u>GAS</u>	<u>PART #</u>	<u>LIST PRICE</u>
ecoSchwank-M 6	N or L	21,500 Btuh	NG	EC-M025-NG	\$ 752.00
			LP	EC-M025-LP	752.00
ecoSchwank-M 10	N or L	35,000 Btuh	NG	EC-M037-NG	801.00
			LP	EC-M037-LP	801.00
ecoSchwank-M 13	N or L	50,000 Btuh	NG	EC-M050-NG	929.00
			LP	EC-M050-LP	929.00
ecoSchwank-M 18	N or L	71,500 Btuh	NG	EC-M075-NG	1,029.00
			LP	EC-M075-LP	1,029.00
ecoSchwank-M 26	N or L	100,000 Btuh	NG	EC-M100-NG	1,137.00
			LP	EC-M100-LP	1,137.00

OPTIONAL ACCESSORIES FOR ECO-M SERIES

		<u>PART #</u>	<u>LIST PRICE</u>
Flexible Gas Connector 1/2" x 18" (Up to 155,000 Btuh)		JL-0771-FF	\$ 25.70
Flexible Gas Connector 1/2" x 24" (Up to 155,000 Btuh)		JL-0771-XX	33.00
#8 Jack Chain - 60 lb work load - box 50'		JL-0798-JC	60.00
#2 Lion Chain - 115 lb work load - 200 ft roll		JL-0800-XX	97.00
'S' Hooks - Package of 25		JL-0798-SH	23.20
Safety Snap Hooks - 2"		JL-0800-SH	40.20
		JL-0800-SH-B	123.00
Pressure Equalizer Venturi Cover (for Drafty Areas)		JO-0368-XX	160.00

ecoSchwank SERIES OTHER ACCESSORIES

Typical accessories: previous page

Transformers: page L-16

EXHAUST SYSTEMS

Schwank no longer offers exhaust fan systems for luminous heaters - these are readily available via local distribution.

Exhaust System Sizing:

- ✓ Luminous heaters are installed unvented
- ✓ Check local & national code requirements
- ✓ National Code Exhaust Volume Requirements (in brief):

☞ **USA:** 4 cfm exhaust per 1,000 Btuh input

☞ **Canada:** 300 cfm interlocked mechanical exhaust per 100,000 Btuh input or any fraction thereof

For all installations, the exhaust or opening for removal of flue products must be located above the level of the heaters.

TILE PROTECTING GRILLE: *Longer lead times for this accessory*

(1/2" X 1/2" Bird Screen)

	PART #	LIST PRICE
For: ecoSchwank 6	JX-0249-XX	\$ 26.70
ecoSchwank 10	JX-0252-XX	26.70
ecoSchwank 13	JX-0253-XX	34.20
ecoSchwank 18	JX-0254-XX	44.90
ecoSchwank 26	JX-0255-XX	52.00

CEILING PROTECTION PLATE: *Longer lead times for this accessory*

For: ecoSchwank 6 & 10	Uninsulated	JX-0256-UN	\$ 128.00
ecoSchwank 13	Uninsulated	JX-0257-UN	149.00
ecoSchwank 18	Uninsulated	JX-0258-UN	202.00
ecoSchwank 26	Uninsulated	JX-0259-UN	246.00

REFLECTOR EXTENSIONS

For: ecoSchwank 6	Single	JX-0260-SG-P	\$ 42.70
	Pair	JX-0260-PR-P	85.40
ecoSchwank 10	Single	JX-0236-SG-P	42.70
	Pair	JX-0236-PR-P	85.40
ecoSchwank 13	Single	JX-0237-SG-P	59.00
	Pair	JX-0237-PR-P	118.00
ecoSchwank 18	Single	JX-0238-SG-P	87.00
	Pair	JX-0238-PR-P	174.00
ecoSchwank 26	Single	JX-0239-SG-P	128.00
	Pair	JX-0239-PR-P	256.00



NEW

Payback in less than one year with typical energy savings



- 'Smart' adaptive recovery
- Single or Two-Stage system control
- Easy set up and configuration
- 8 programmable holiday periods
- Locking cover
- NEMA 13 enclosure
- IR sensor can be installed indoors or outdoors
- Coming soon ... RS232/485 interface
 - CM232 includes BMS software
 - CM485 communicates with existing BMS

THERMOCONTROL PLUS 1 - 1 to 2 ZONE		JM-0504-TK-1
- Control: One or two Single-Stage Zones; or one Two-Stage Zone		<u>Qty</u>
Includes	ThermoControl Outdoor Air Temperature Sensor	1
	24V Transformer 100VA* (24Vac powers control & relays)	1
	24V External Relay switches power to zone transformer & fan	2

THERMOCONTROL PLUS 2 - 1 TO 4 ZONE		JM-0504-TK-2
- Control: up to four Single-Stage Zones, or two Two-Stage Zone		<u>Qty</u>
Includes	ThermoControl Outdoor Air Temperature Sensor	1
	24V Transformer 100VA* (24Vac powers control & relays)	1
	24V External Relay switches power to zone transformer & fan	4

THERMOCONTROL PLUS 4 - 1 TO 8 ZONE		JM-0504-TK-4
- Control: up to eight Single-Stage Zones, or four Two-Stage Zone		<u>Qty</u>
Includes	ThermoControl Outdoor Air Temperature Sensor	1
	24V Transformer 100VA* (24Vac powers control & relays)	1
	24V External Relay switches power to zone transformer & fan	8

*Refer to chart and guidelines next page:
Zone Schemes and Component Quantity*

Call your local Schwank representative for project design and pricing of the ThermoControl Plus

* The supplied 24Vac 100VA transformer powers the control panel and external relays at each heater zone. Order a separate 24Vac transformer for each heater zone to power heaters - see page 15.

IR Sensor Required : ThermoControl RADIANT SENSOR JM-0505-XX
- Minimum one required per zone, or for 'temperature averaging' four required per zone

Optional: SETBACK OVERRIDE Push Button Switch JM-0509-XX

more information next page ...

ThermoControl Plus

.... continued

Schwank
INNOVATIVE HEATING SOLUTIONS



IR Sensor
Order separately

- IR sensor senses and averages radiant and ambient temperatures for true comfort control
- Indoor or outdoor installation
- Use one sensor per zone, or use four to get temperature averaging
- Outdoor air temperature sensor included with control for 'smart' adaptive recovery from setback

Zone Schemes and Component Quantity

CONTROLLER	ORDER PART #	Zone Control Combinations		Total Number of Zones	ALSO ORDER:		
		Single Stage	Two Stage*		RADIANT SENSORS JM-0505-XX		Optional Setback Override JM-0507-XX
					Minimum 1 per Zone	OR Temperature Averaging	
ThermoControl Plus 1	JM-0504-TK-1	2	-	2	2	8	2
		1	-	1	1	4	1
		1	1	2	2	8	2
ThermoControl Plus 2	JM-0504-TK-2	4	-	4	4	16	4
		3	-	3	3	12	3
		2	1	3	3	12	3
		1	1	2	2	8	2
ThermoControl Plus 4	JM-0504-TK-4	8	-	8	8	32	8
		7	-	7	7	28	7
		6	-	6	6	24	6
		6	1	7	7	28	7
		5	-	5	5	20	5
		5	1	6	6	24	6
		4	2	6	6	24	6
		2	3	5	5	20	5
		1	3	4	4	16	4
-	4	4	4	16	4		

* Two-Stage Zone: Control single-stage heaters with 50% or more heaters in Stage 1, balance in Stage 2

Guidelines:

1. ThermoControl Plus controllers have 24Vac 'wet' contacts. Call for heat activates 24Vac to external power relays
2. A sufficient quantity of External Power Relays are supplied with the ThermoControl Plus to switch 120Vac to exhaust fan and to 120/24V heater transformer in each of the zones
3. Zone Sizes: Luminous heaters - Up to 12 heaters per zone (limited by exhaust fan capacity)
4. No additional control centers or relays are required

See Tube Heater section for information on controlling tube heaters with the ThermoControl Plus

TruTemp
 Infrared Setback
 Thermostat



SCHWANK TruTemp INFRARED SETBACK THERMOSTAT

NOT FOR USE IN WET ENVIRONMENTS

The only infrared thermostat that senses and averages radiant and ambient temperatures for true comfort control and efficient radiant heating system operation. An automatic setback feature further adds to fuel savings when the heated space is unoccupied. TruTemp thermostat can be used in conjunction with all Schwank heaters. 4" Diameter fits standard electrical box.

<u>ITEM</u>	<u>VOLTAGE</u>	<u>PART #</u>	<u>LIST PRICE</u>
TruTemp Thermostat	24 Volt	JM-0150-XX	\$ 213.00

FIELD MOUNTED OPTION REQUIRED FOR TruTemp THERMOSTAT OPERATION (see Guidelines next page)

- **MULTIPLE LUMINOUS HEATERS** with **SINGLE TruTemp** per ZONE

ORDER **TruTemp +**

1 Transformer/Relay
 (Field Mounted)



JM-0300-XX \$ 107.00

The transformer/relay provides 24V to the TruTemp. Call for heat by TruTemp closes relay switch, sending 120V to the system transformer (required separately) to power up heaters.

SECURITY OPTION TO PREVENT UNAUTHORIZED TAMPERING

Two S/S Tamperproof Screws and One Tool
 (Order for the First TruTemp on Project)

JM-0180-XX \$ 65.00

Two S/S Tamperproof Screws
 (Order for Each Additional TruTemp on Project)

JM-0180-AA 6.50

24V TRANSFORMERS

for ALL LUMINOUS (High Intensity) HEATERS

<u>QTY HEATERS*</u>	<u>SIZE</u>		<u>PART #</u>	<u>LIST PRICE</u>
1 Heater	40 VA Transformer	4"x4" Electrical Box Mount	JL-0776-XX	\$ 70.00
Up to 4	100 VA Transformer	Closed Type	JL-0778-XX	131.00
5 to 6	150 VA Transformer	Closed Type	JL-0779-XX	157.00
7 to 9	200 VA Transformer	Closed Type	JL-0780-XX	180.00
10 to 12	250 VA Transformer	Closed Type	JL-0781-XX	197.00
13 to 16	350 VA Transformer	Closed Type	JL-0781-AA	230.00

* Except patioSchwank - See Below for Sizing Guidelines

See INSTALLATION MANUAL to determine gauge of wire to be used. minimum 16 gauge).

24V TRANSFORMER SIZING:

For Space & Area Heating & Process Applications

- 1] Transformer mounted at heater:
 - . Use 40 VA 24V transformer for each individual heater.
- 2] Transformer mounted remote from heater:
 - . - On a single heater use one 40 VA 24V transformer.
 - . - On a zone with multiple heaters, use transformer sized at 40VA per first heater plus 20VA for each additional heater

For patioSchwank 2300 Series

- On a single heater use one 40 VA 24V transformer.
- On a zone or patioPanel with multiple heaters, use transformer sized at 40 VA for the first heater and 20 VA per each additional heater.

LUMINOUS HEATER 24V CONTROL OPTION GUIDELINES

for: TruTemp / 24V Thermostat / patioPanel / Remote Control

<p>Single heater per low voltage control zone requires one 40VA transformer (JL-0776-XX) per heater.</p>
<p>Multiple heaters per zone: maximum 15 heaters per TruTemp or 24V Thermostat ORDER per ZONE - 1 TruTemp or 24V Thermostat + 1 Transformer Relay (JM-0300-XX) + 1 Transformer</p>
<p>OBSERVE THE FOLLOWING ONLY IF THE HEATING SYSTEM REQUIRES INTERLOCK TO AN EXHAUST FAN. (Canada B-149)</p> <p>FOR TruTemp or 24V Thermostat Control:</p> <ul style="list-style-type: none"> - ORDER for EACH ZONE - one JM-0300-XX Transformer Relay + one TruTemp or 24V thermostat - 120V to the transformer relay -> supplies 24V to the thermostat. - Call-for-heat: 24V through thermostat to the relay: relay closes providing 120V to the exhaust fan. - Proving air switch at exhaust fan closes, supplying 120V to the heater zone transformer. - NOTE: The transformer relay does not directly energize the heaters in the system. <ul style="list-style-type: none"> - A separate transformer is required to power the 24V heaters. - Size transformer: 40VA for 1st heater + 20VA for each additional heater in the zone (see page L-13). <p>The number of heaters in any zone is determined by the following zone sizing parameters:</p> <ol style="list-style-type: none"> 1) the capacity of the exhaust fan. 2) the proximity of the heaters to the fan. 3) Quantity of heaters required to satisfy zone size conditions of the project site.

TUBE HEATER 24V GUIDELINES are on page T-51

GAS CONVERSION KITS SCHWANK LUMINOUS HEATERS

NOTE: Conversion kits are NOT available for: 2000 Series luminous heaters (high intensity) - contact Schwank

When ordering, please provide heater model number and gas type to convert to

SCHWANK LUMINOUS (HIGH INTENSITY) HEATERS

<u>Heater Model</u>	<u>NG to LP</u>	<u>LP to NG</u>	<u>List Price</u>
ECO 6, 2312	JC-CADL-KX	JC-CADN-KX	\$ 48.00
ECO 8, JR-25	JX-0253-XA-A	JX-0252-XA-A	48.00
ECO 10, 2313, JR-37	JX-0253-XA	JX-0252-XA	48.00
ECO 13, 2315, JR-50	JX-0253-XB	JX-0252-XB	48.00
ECO 18, JR-75	JX-0253-XC	JX-0252-XC	48.00
ECO 26, JR-100	JX-0253-XD	JX-0252-XD	48.00
ECO 36	JX-0253-XC-A	JX-0252-XC-A	57.00
ECO 52	JX-0253-XD-A	JX-0252-XD-A	57.00
	<u>NG to LP</u>	<u>LP to NG</u>	
PRIMO 10	JO-0350-XX	JO-0349-XX	\$ 47.00
PRIMO 15	JO-0348-NG	JO-0348-LP	47.00
PRIMO 20	JO-0352-XX	JO-0351-XX	47.00
PRIMO 30	JO-0354-XX	JO-0353-XX	47.00
PRIMO 40	JO-0352-XX-A	JO-0351-XX-A	87.00
	<u>NG to LP</u>	<u>LP to NG</u>	
SUPRA 10	JU-0350-XX	JU-0349-XX	\$ 48.00
SUPRA 15	JU-0352-XX	JU-0351-XX	48.00
SUPRA 20	JU-0354-XX	JU-0353-XX	48.00
SUPRA 30	JU-0356-XX	JU-0355-XX	48.00
SUPRA 40	JU-0354-XX-A	JU-0353-XX-A	87.00

ARENA SPECTATOR 'COMFORT' HEATING

Contact Schwank Design for Arena Heating: Fax 1-866-724-9265; design@SchwankGroup.com

In community arenas, infrared spot heating is the most effective solution for spectator areas. Desired 'comfort' results directly from the contact of infrared radiant heat produced by an IR heating system.

In designing an arena spectator heating system, it is necessary to remember that "heat" in an ice-making facility is somewhat counter productive to the efforts of facility staff to produce and maintain both the ice and the facility structure.

Any convection heat produced by the IR system is detrimental to arena facility ice-making operations, and the moisture in the products of combustion can have a negative impact on structure by condensing on the cold interior surfaces of the building.

NOTE: Schwank does not recommend the use of tube heaters for arena spectator heating due to lower radiant intensity and less effective focus or direction of the infrared heat output. However, in exceptional cases tube heaters can be used as an alternate.

As far as arena staff are concerned, spectator heating is viewed strictly as a "necessary evil".

The optimum arena heating design must not only provide spectator comfort, but must also reduce the concerns of the arena staff regard arena operation. Schwank luminous heaters meet and exceed these requirements:

Design the system with heaters of the highest possible infrared radiant efficiency that will 'fit' the budget. Maximize spectator comfort while minimizing operating costs and any negative impact on arena operations.	Schwank luminous heaters have higher infrared radiant efficiencies than <u>ANY</u> competitor's models: Good ecoSchwank = 50% IR output - others have 35% Better primoSchwank = 67% IR output - NO competitors Best supraSchwank = 81% IR output = <u>world's</u> highest
Lowest total input has the least negative impact on arena operations: least 'waste heat', least moisture produced.	The high radiant efficiency of Schwank luminous heaters ensures lowest input for maximum spectator comfort. The supraSchwank (81% IR efficient) is by far the most effective choice.
The fewest possible heaters operating for the shortest period of time ensure the least negative impact while providing the desired spectator comfort.	Schwank's highest radiant efficiencies ensures that the fewest heaters will do the job, while the Arena Control Panel provides individual control of each heater or small 'zones'. The panel's master override timer guarantees that the system will shut down when required - it just simply doesn't "forget" to shut heaters down.

SCHWANK ARENA CONTROL PANEL

ARENA CONTROL PANEL CENTRALLY CONTROLS THE DURATION OF OPERATION OF SCHWANK HEATERS FOR ARENA SPECTATOR HEATING, OR ANY APPLICATION WHERE DURATION CONTROL OF MULTI-ZONE HEATING IS REQUIRED.

- Includes: A master timer that is adjusted by the operator to the desired duration of heating system operation;
- A master on/off switch with status light;
- The quantity of switches with status lights to match the number of zones/heaters being installed;
- All components mounted on an 11" x 13" x 4" deep control box with hinged front panel;
- Also included separately is a transformer relay (field installation required) to power the arena panel;
- Not included is any 120/24 Volt transformer required to power high intensity luminous heaters (refer to page L-13 for 24V transformer sizing and pricing).

NOTE: Indicate the number of heating zones required when ordering an Arena Panel.
 For arena applications, Schwank recommends one (or at most two) heaters per zone.
 For extraordinary projects contact Schwank.

<u>MODEL</u>	<u>NUMBER OF HEATERS or ZONES</u>	<u>PART #</u>	<u>LIST PRICE</u>
ACPT- 8	<i>up to</i> 8	JM-0408-XX	\$ 1,177.00
ACPT-12	<i>up to</i> 12	JM-0412-XX	1,267.00
ACPT-16	<i>up to</i> 16	JM-0416-XX	1,381.00



Schwank
 INNOVATIVE HEATING SOLUTIONS



TUBE HEATER PRICE LIST USA 2011

PRICES IN EFFECT APRIL 1, 2011

RELEASE 11-1A

Tube Heaters:	This Section, Pages T-1 to T-62
Other Price List Sections:	
General Information: Terms; Return Policy; Contact Info; Freight Zones; SPQ Form; Design Form; Warranty Summary - Pages G-1 to G-11	
Luminous Heaters (High Intensity):	Section 2, Pages L-1 to L-18
Outdoor & patioSchwank:	Section 4, Pages P-1 to P-35

Schwank Group

2 Schwank Way,
 Waynesboro, GA 30830

5285 Bradco Blvd
 Mississauga, Ontario. L4W 2A6

Orders, Customer Service, Technical Support

1-877-446-3727

Fax: 1-866-361-0523

Design Services

USA Fax: 1-866-361-0523

design@schwankgroup.com

Inquiry email: csr@schwankgroup.com



Visit our website for current product information

www.Schwankgroup.com

Select **PUBLISHED INFO** from menu, then Register or Login

These price sheets are the proprietary information of Schwank. This publication, or parts thereof, may not be reproduced in any form or reposted electronically without prior written consent from Schwank. Unauthorized use or distribution is strictly prohibited.



All Schwank heaters are certified by CSA International

As of the effective date, these price sheets supercede all previous price sheets.



TABLE OF CONTENTS

LUMINOUS HEATERS	Luminous Heaters & Accessories: see Section 2 pages L-1 to L-18 Luminous Heater Table of Contents is on page L-3	
<hr/>		
TUBE HEATERS	What's New In TUBES?	T-5
<hr/>		
ultraSchwank	UHE Series Positive Pressure Tube Heater Systems	T-6
	UHE Assembly Chart for Burner & Tube Kits	T-7
	UHE Burner Kits & Gas Conversion Kits	T-8
	UHE Tube Kits	T-9
	UHE Controls & Typical Accessories	T-10
<hr/>		
premierSchwank	STS-JZ Heater & Accessories Selection Guide	T-11
	STS-JZ Series Positive Pressure Tube Heater Systems	T-12
	STS-JZ Assembly Chart for Burner & Tube Kits	T-13
	STS-JZ Burner Kits & Gas Conversion Kits	T-14
	STS-JZ Tube Kits	T-15
<hr/>		
	STV-JZ Vacuum Series Tube Heater Complete Systems	T-16
	STV-JZ: Burner + Tube Kit + Vacuum Pump Assembly Charts	T-17
	STV-JZ Tube Kits	T-18
<hr/>		
	Optional Accessories for UHE & ST-JZ Series Tube Heaters	T-19 - 21
	Thermostats & Controls for UHE & ST-JZ Series Tube Heaters	T-22
<hr/>		
builderSchwank	S100 / S100U Heater & Accessory Selection Chart	T-23
Budget Performance Series	S100 Series Tube Heater Complete Systems	T-24
	S100 Assembly Chart for Burner & Tube Kits	T-25
	S100 Burner Kits & Gas Conversion Kits	T-26
	S100 Tube Kits	T-27
	S100U Tube Heaters Complete Systems	T-28
	S100U Assembly Chart for Burner & Tube Kits	T-29
	S100U Burner Kits & Gas Conversion Kits	T-30
	S100U Tube Kits	T-31
<hr/>		
WhisperJet Two Stage	SET Series Tube Heater Complete Systems	T-32
	SET Assembly Chart for Kits; Tube Kits	T-33
	SET & SETU Burner Kits & Gas Conversion Kits	T-34
	SETU Tube Heater Complete Systems	T-35
	SETU Assembly Chart for Kits; Tube Kits	T-36
	SET & SETU Burner Kits & Gas Conversion Kits	T-37
<hr/>		
	Optional Accessories for S100 & SET Series Tube Heaters	T-38 - 40
	Thermostats & Controls for S100 & SET Series Tube Heaters	T-41
<hr/>		
RESIDENTIAL	STR-JZ Workshop/Garage Tube Heater Complete Systems & Kit Assembly Chart	T-42
	STR-JZ Burner Kits; Tube Kits; Gas Conversion Kits	T-43
	STR-JZ Optional Accessories	T-44

CAR WASH Next page

continued next page



TABLE OF CONTENTS *continued*

CAR WASH	Harsh Environment & Outdoor Tube Heaters: Introduction -Read Me	T-45
SPW-JZ has Powder Coated Cabinet	SPW-JZ Series Outdoor Patio & Hand Carwash Tube Heater Complete Systems	T-46
	SPW-JZ Assembly Chart for Burner & Tube Kits	T-47
	SPW-JZ Burner Kits: Powder Coated Burner Cabinet.....	T-48
	Aluminized Steel Tube Kits	T-52
STW-JZ has Stainless Steel Cabinet	STW-JZ Series Carwash Tube Heater Complete Systems	T-49
	STW-JZ Assembly Chart for Burner & Tube Kits	T-50
	STW-JZ & STW-JZ2 Burner Kits.....	T-51
	Aluminized Steel Tube Kits	T-52
Stainless Steel Tubes & Reflectors	STW-JZ2 Assembly Chart for Burner & Stainless Steel Tube Kits	T-53
	STW-JZ & STW-JZ2 Burner Kits.....	T-51
	Stainless Steel Tube Kits - STW-JZ2 Series	T-54 - 56
	Optional Accessories for STW-JZ & SPW-JZ Tube Heaters	T-55 - 57

ENERGY CONTROLS	ThermoControl Plus - Building Management System	T-58
	TruTemp Infrared Setback Thermostat.	T-60

MISCELLANEOUS	24V Option Guidelines	T-61
	Gas Conversion Kits for all Schwank Tube Heater	T-62

PATIO HEATERS *Section 4: Refer to Index page P-3*

***Please order tube heaters using burner kit & tube kit part numbers
 Tube heaters are shipped & invoiced as burner kits & tube kits***

These price sheets supercede all other price sheets

Schwank reserves the right to make changes in products and pricing without notice.

F.O.B. Mississauga, Ontario or Waynesboro GA
 All Applicable Taxes Extra
 Terms: Net 30 Days
 1% Monthly Interest On Overdue Accounts
 Prices subject to change without notice



What's New in Tubes for 2011?

NEW In USA Release 1A - April 1, 2010

Please update your sales information and database with these New Models & Numbers!

Reminder

ultraSchwank - page 6

- *Payback in as little as one year versus other tube heaters*
- *North America's highest radiant efficiency tube heater*
- *Newly engineered high efficiency burner*
- *Insulated reflector system*

Reminder

ThermoControl Plus - page 58

- *Programmable building management system*
- *True comfort control of IR systems*
- *Payback in less than one heating season*
- *'Smart' adaptive recovery*
- *3 models with up to 8 single or 4 two-stage zone control*

Reminder

EFFECTIVE JUNE 2009 - FLEX GAS CONNECTOR SUPPLIED WITH HEATER

ANSI Z83.20-2008 / CSA 2.34-2008

Revised Standard for Gas-Fired Low-Intensity Infrared Tube Heaters

requires the mandatory supply of specific gas connector by the manufacturer:

Refer to model information pages for the gas connector that is included with the heater.

www.SchwankGroup.com - Get current Published Info for all products



ultraSchwank Tube Heater UHE Series

**Highest Radiant Output
Tube Heater**



**Payback in as little as one year
versus other tube heaters**

**Schwank's complete Design Service
will show your customer the savings!**

FEATURES SUMMARY:

- NEW high efficiency burner
- Insulated Reflector & End Caps
- Highest IR Heat Output
- Up to 62% Radiant Factor
- 24V or Line Voltage Thermostat Ready
- Status Indicator Lights
- Power Cord with Plug
- Birdscreened Combustion Air Collar
- Swing-down Cabinet Service Access
- Whisper Quiet Ceramic Burner
- Emissive Coated Radiant Tubes

**Call your local Schwank
representative for project
design and pricing of the
ultraSchwank**

COMPLETE SYSTEMS:

<u>MODEL</u>	<u>CAPACITY</u>	<u>AVAILABLE TUBE LENGTH</u>
UHE 60	60,000 Btuh	20'
UHE 90	90,000 Btuh	30'
UHE 130	130,000 Btuh	40'
UHE 160	160,000 Btuh	50'
UHE 200	200,000 Btuh	60'
		70'

Model UHE is currently available in Natural Gas Only

Orders are shipped & invoiced as individually cartoned Burner Kits + Tube Kits

Burner Kits, and tube kits are packaged separately and clearly labelled for ease of assembling orders and shipping

- Please order heater(s) by Burner Kit(s) + Tube Kit(s)

ABOVE SYSTEMS INCLUDE BURNER KIT & REQUIRED TUBE KIT(S) FOR HEATER LENGTH

BURNER KIT: FLEXIBLE GAS CONNECTOR, ELECTRICAL CORD, STATUS INDICATOR LIGHTS, FACTORY MOUNTED IGNITER, FACTORY INSTALLED 24/120V RELAY SWITCH, DROP-DOWN SERVICE ACCESS, BIRDSCREENED AIR INTAKE WITH COLLAR ON BLOWER

OPTIONAL: - WALL OR ROOF COMBUSTION AIR INTAKE CAP

- THERMOSTAT - Best Performance with ThermoControl Plus building management system (see page 57) or TruTemp Infrared Setback thermostat (see page 59)

TUBE KIT: PRIMARY TUBE(S), SECONDARY TUBE(S) WITH EMISSIVE COATING, INSULATED REFLECTORS, REFLECTOR END CAPS, HANGERS FOR TUBES & REFLECTORS, TUBE COUPLER(S) AND TURBULATOR(S).

OPTIONAL: 90° MODULAR ELBOW KIT (combine two 90's to create 180° elbow)

BURNER & TUBE KIT CHART: next page
Ultra BURNER KITS: page 8
Ultra TUBE KITS: page 9
Controls & TypicalAccessories: page 10



ultraSchwank Tube Heater UHE Series

BURNER & TUBE KIT ASSEMBLY CHART

Which tube kits assemble with a burner kit?

Use the chart below to determine:

- ✓ Available tube length for each firing rate
- ✓ Available tube kit & quantities for each burner kit

- 1) Select HEATER MODEL / INPUT
- 2) Order BURNER KIT
Includes Required Gas Connector
- 3) Order Quantity(s) of TUBE KIT(s)

 ANSI Standards require the manufacturer to supply a flexible gas connector with a tube heater. The flexible gas connector is included in the Burner Kit.

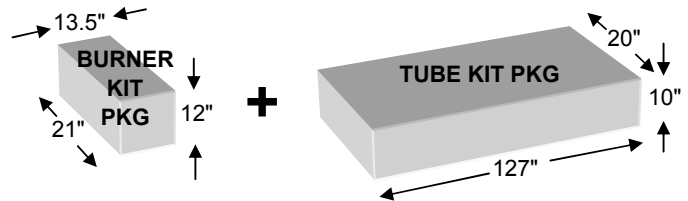

BURNER & TUBE KIT ASSEMBLY CHART

ultraSchwank UHE: High radiant output tube heater
Commercial / Industrial Applications

		Order: TUBE KIT PART # & QUANTITY REQUIRED								
		COMPLETE	PRIMARY TUBE KITS			SECONDARY TUBE KITS				
		60 Mbh	60 to 130	160 & 200	20 ft Secondary Kits			10 ft Secondary Kits		
Turbulator*		6 ft	None	None	None	2 ft	6 ft	None	3 ft	
Tube Kit Part #		TK-P620-UL	TK-P020-UL	TK-PH20-UL	TK-S020-UL	TK-S220-UL	TK-S620-UL	TK-S010-UL	TK-S310-UL	Approx. Weight (lbs)
Input Btuh	Tube Length	20'	20'	20'	20'	20'	20'	10'	10'	
60,000	20'	1								190
	30'		1+					1		272
90,000	30'		1+						1	272
	40'		1+		1					354
130,000	40'		1+				1			354
	50'		1+		1+			1		436
160,000	50'			1+			1	1		436
	60'			1+	1+	1				518
200,000	50'			1+		1+		1		436
	60'			1+	1+	1				518
	70'			1+	2+			1		600

"Complete" tube kit requires no additional tube kits.
Primary tube kits require at least one additional Secondary tube kit.
Secondary tube kit requires a Primary tube kit.

MODEL UHE IS AVAILABLE IN NATURAL GAS ONLY

Complete Systems: page 6
Ultra BURNER KITS: next page
Ultra TUBE KITS: page 9



ultraSchwank Tube Heater UHE Series

BURNER KITS

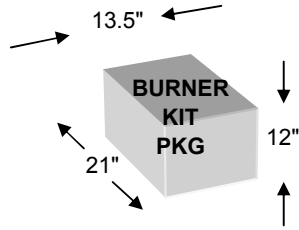

ANSI Standards require the manufacturer to supply a flexible gas connector with a tube heater. The flexible gas connector is included in the Burner Kit.

BURNER KITS ARE AVAILABLE IN NATURAL GAS ONLY

BURNER INCLUDES: STAINLESS STEEL FLEXIBLE GAS CONNECTOR, STATUS INDICATOR LIGHTS, ELECTRICAL CORD & PLUG, MOUNTED IGNITER, BIRDSCREENED 4" DIAMETER AIR INTAKE ADAPTER ON BLOWER.

<u>CAPACITY</u>	<u>AVAILABLE TUBE LENGTHS</u>	<u>FUEL</u>	<u>INCLUDES S/S FLEX GAS CONNECT</u>	<u>BURNER PART #</u>
60,000 Btuh	20', 30'	N.G.	1/2" X 24"	JS-U060-BN
90,000 Btuh	30', 40'	N.G.	1/2" X 24"	JS-U090-BN
130,000 Btuh	40', 50'	N.G.	1/2" X 24"	JS-U130-BN
160,000 Btuh	50', 60'	N.G.	3/4" X 36"	JS-U160-BN
200,000 Btuh	50', 60', 70'	N.G.	3/4" X 36"	JS-U200-BN

Call your local Schwank representative for project design and pricing of the ultraSchwank

Burner kit contains: Burner assembly, Stainless Steel Flexible Gas Connector, installation manual; the burner fastening nuts & bolts are packed inside the burner housing. All optional accessories are shipped in separate carton.

All burner assemblies operate on line voltage (120VAC).

ultraSchwank Tube Heaters

UHE Series



TUBE KITS (emissive coated)

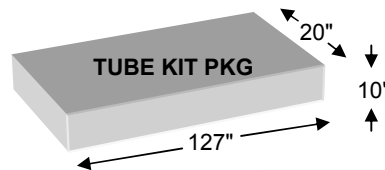

FEATURES of the ultraSchwank Tube System:

- Insulated reflectors
- Flexible location of hangers
- Modular 90° elbow kit with reflector cover
~ simply combine two 90's to make a 180

- Stand-Alone** tube kit requires no additional tube kits.
- Primary** tube kits require at least one additional Secondary tube kit.
- Secondary** tube kit require a Primary tube kit.

Suspension: Calculate for each heater:
#2 Lion Chain: (JL-0800-XX - 200 ft roll)
[(tube length/10) x 2 + 1] x length
needed at each suspension point
 ie: 40' = (40/10) x 2 + 1 = 9 x chain length
 at each suspension point
'S' hooks: (JL-0798-SH - 1-7/8" pkg of 25)
(tube length/10) x 4 + 2
 ie: 40' = (40/10) x 4 + 2 = 18

Refer to the Chart on page U-2 for correct Burner & Tube Kit Combinations

<u>Stand-Alone</u>	(Each kit includes Insulated Reflectors, System Hangers, Tube Couplers, Turbulator as required)	<u>TUBE KIT #</u>
20' : 60,000 only	One flanged/swaged aluminized tube with no ports, one emissive coated steel swaged tube, one 4 ft turbulator and one 10 ft turbulator	TK-P620-UL
Primary Kits - require Secondary Kit(s) to make 30', 40', 50', 60' & 70' heaters		
20' : 60, 90 & 130,000	One flanged/swaged aluminized tube with no ports, one emissive coated steel swaged tubes, no turbulator	TK-P020-UL
20' : 160 & 200,000	One flanged/swaged alumatherm tube with no ports, one aluminized swaged tube, no turbulator	TK-PH20-UL
Secondary Kits - add to above Primary Kits to make 30', 40', 50', 60' & 70' heaters		
20'	Two emissive coated steel swaged tubes, no turbulator (+ 20' primary = 40' heater) Use: 90,000 x 40'; 130,000 x 50'; 160,000 x 60'; 200,000 x 60' & 70'	TK-S020-UL
20'	Two emissive coated steel swaged tubes, 2 ft turbulator (+ 20' primary = 40' heater) Use: 160,000 x 60'; 200,000 x 50' & 60'	TK-S220-UL
20'	Two emissive coated steel swaged tubes, 6 ft turbulator (+ 20' primary = 40' heater) Use: 130,000 x 40'; 160,000 x 50'	TK-S620-UL
10'	One emissive coated steel swaged tube, no turbulator Use: 60,000 x 30'; 130,000 x 50'; 160,000 x 50'; 200,000 x 50' & 70'	TK-S010-UL
10'	One emissive coated steel swaged tube, 3 ft turbulator Use: 90,000 x 30'	TK-S310-UL

Call your local Schwank representative for project design and pricing of the ultraSchwank

Do not extend heater length beyond the maximum length approved and listed for any input.

ultraSchwank Tube Heaters

UHE Series



Recommended Control Options for ultraSchwank:

ThermoControl Plus
- Building Management System
(°F & °C scales)



See more info on the
ThermoControl Plus on
pages T-58 & T-59

TruTemp Infrared Setback Thermostat
(°F & °C scales)
(see more info on the TruTemp on page T-60)



JM-0150-XX \$ 213.00

Typical Accessories:

Hanging Chain:

UHE Series: #2 Lion Chain - 115 lb work load - 200 ft roll

PART # **LIST PRICE**

JL-0800-XX \$ 97.00

Do NOT use # 8 Jack Chain for ultraSchwank



Chain quantity per UHE Series heater = ((heater tube length/10) x 2) + 1 x length of chain at each suspension point
ie: UHE 40 ft heater 3 ft below structural support = ((40/10) x 2) + 1 x 3 = 27 ft of chain

Safety Snap Hooks* - 2"



Package of 24 JL-0800-SH 40.20
Package of 100 JL-0800-SH-B 123.00

* UHE Series quantity required = ((tube length/10) x 4) + 2 : ie: UHE x 40 ft = (40 ft/10) x 4) + 2 = 18 hooks

CLEARANCE TO COMBUSTIBLES SIGN



JL-0798-CS 37.10

Metal sign - 18" x 6"

- 3/4" red lettering on white background

ultraSchwank 90° Aluminized Steel Elbow Kit

JS-0508-UL 160.00

(90° Kit include: one elbow, one 4" swaged tube coupler and reflector cap)

ultraSchwank 180° Elbow Kit:

Use two 90° Kits to create a 180°

For 180° Aluminized Steel Elbow Kit - Order TWO x JS-0508-UL

JS-0508-UL x 2 320.00

See more accessory options on Pages 19, 20 & 22

premierSchwank STS-JZ Series Heater & Accessory Selection Guide

**STS-JZ SERIES IS STOCKED IN NATURAL GAS ONLY
FIELD CONVERSION KIT REQUIRED FOR LP GAS**
(SEE DETAILS IN PRICE PAGES)

STS-JZ BURNER KITS

45,000	STS-JZ-45	JS-S045-AN
60,000	STS-JZ-60	JS-S060-AN
80,000	STS-JZ-80	JS-S080-AN
100,000	STS-JZ-100	JS-S100-AN
110,000	STS-JZ-110	JS-S110-AN
130,000	STS-JZ-130	JS-S130-AN
155,000	STS-JZ-155	JS-S155-AN
175,000	STS-JZ-175	JS-S175-AN
200,000	STS-JZ-200	JS-S200-AN

**SELECT ONE TYPE OF TEMPERATURE CONTROL DEPENDING ON
VOLTAGE AND QUANTITY OF THERMOSTAT(S) REQUIRED**
NOTE: WHEN TWO HEATERS ARE COMMON VENTED, BOTH
HEATERS MUST BE CONTROLLED BY THE SAME THERMOSTAT

EITHER

LINE VOLTAGE THERMOSTAT
JL-0772-XX
CALL FOR HEAT POWERS HEATER
THERMOSTAT NOT INCLUDED WITH HEATER

OR

24 VOLT THERMOSTAT JS-0569-WR
for 2 or More Heaters per Thermostat, requires
24 VOLT TRANSFORMER/ RELAY JM-0303-KT
CALL FOR HEAT POWERS RELAY

OR

TRU-TEMP THERMOSTAT (24V)
JM-0150-XX
SENSES AMBIENT AND
RADIANT TEMPERATURES
FOR OPTIMUM ENERGY SAVINGS & COMFORT
CALL FOR HEAT POWERS RELAY

AND

FOR SINGLE STS- PER THERMOSTAT
ONE THERMOSTAT CONTROLS ONE HEATER
STS-JZ IS FACTORY READY FOR
24V or LINE VOLTAGE THERMOSTAT
OR TRU-TEMP THERMOSTAT:
THERMOSTAT NOT INCLUDED WITH HEATER

OR

**FOR MULTIPLE STS- PER 24V THERMOSTAT
TRANSFORMER / RELAY JM-0303-KT**
THERMOSTAT CONTROLS 2 to 7 HEATERS
REQUIRED WITH 24 VOLT THERMOSTAT
OR TRU-TEMP THERMOSTAT
THERMOSTAT NOT INCLUDED IN RELAY KIT

TUBE KIT(S) See larger detail in Price Pages

ORDER: BURNER KIT + TUBE KIT(S)

MODEL #	BURNER KIT WT = 30 lb	Includes Type of Gas Connector	STS-JZ TUBE KIT PART # & QUANTITY REQUIRED											
			Stand-Alone Kits			Primary Kits +			Secondary Kits					
10'	20'	30'	10'	20'	30'	10'	20'	30'	10'	20'	30'			
STS-JZ 45	JS-S045-AN	1/22"xø3/8"	1											
STS-JZ 60	JS-S060-AN	1/22"xø3/8"		1										
STS-JZ 80	JS-S080-AN	1/22"xø3/8"			1									
STS-JZ 100	JS-S100-AN	1/22"xø3/8"		1										
STS-JZ 110	JS-S110-AN	1/22"xø3/8"				1			1+		1			
STS-JZ 130	JS-S130-AN	3/4"xø3/8"				1			1+		1			
STS-JZ 155	JS-S155-AN	3/4"xø3/8"					1		1+		1	1		
STS-JZ 175	JS-S175-AN	3/4"xø3/8"						1+	1+	1	1	1		
STS-JZ 200	JS-S200-AN	3/4"xø3/8"						1+	1+	1	1	1		

Tube Kit Gross Weight (lbs) → 70 120 120 170 210 165 165 120 165 210

**SINGLE HEATER VENT
TERMINATION CAP**
4" Horizontal Wall Cap JA-0528-XX
OR 4" Roof Vent Cap JA-0530-XX

S' HOOKS - PKG OF 25
JL-0798-SH

4" X 4" X 6" TEE
JA-0514-XX
Used for:
COMMON VENTING
of TWO Systems
* Requires common
Thermostat

50' JACK CHAIN KIT
JL-0798-JC
Number Suspension Points:
= (Heater Length ÷ 10) + 1
i.e.: 50' Heater = (50/10)+1 = 6

AND

6" Horizontal Wall Cap JA-0529-XX
OR 6" Roof Vent Cap JA-0531-XX

ELBOW KITS
90° Elbow Kit JS-0508-JZ
180° Elbow Kit = 2 x JS-0508-JZ



premierSchwank Tube Heaters

STS-JZ Series

Straight Tube - emissive coated



- STS-JZ FEATURES SUMMARY:
- 24V or Line Voltage Thermostat Ready
 - Status Indicator Lights
 - Power Cord with Plug
 - Birdscreened Combustion Air Collar - 4"
 - Swing-down Cabinet Service Access
 - Whisper Quiet Ceramic Burner
 - 'Focus Shield' Reflector & End Caps for Premier IR Heat Output
 - Emissive Coated Radiant Tubes

COMPLETE SYSTEMS:

<u>MODEL</u>	<u>CAPACITY</u>	<u>AVAILABLE TUBE</u>		<u>LIST PRICE</u>
		<u>LENGTH</u>		
STS-JZ 45	45,000 Btuh	10'	\$	1,298.00
		20'		1,422.00
STS-JZ 60	60,000 Btuh	20'		1,422.00
		30'		1,618.00
STS-JZ 80	80,000 Btuh	20'		1,422.00
		30'		1,618.00
STS-JZ 100	100,000 Btuh	40'		1,813.00 *
		20'		1,515.00
STS-JZ 110	110,000 Btuh	30'		1,618.00
		40'		1,813.00 *
		50'		2,091.00
STS-JZ 130	130,000 Btuh	30'		1,618.00
		40'		1,813.00 *
		50'		2,091.00
STS-JZ 155	155,000 Btuh	40'		1,882.00 *
		50'		2,160.00
		60'		2,355.00
STS-JZ 175	175,000 Btuh	50'		2,263.00
		60'		2,458.00
		70'		2,654.00
STS-JZ 200	200,000 Btuh	50'		2,263.00
		60'		2,458.00
		70'		2,654.00

Individual burner kits + tube kits are shipped to assemble tube heater orders.
~ See next page for details ~

* 40 ft heater price based on using TS-1040-JZ tube kit

NOTE:
Standard burners are stocked for natural gas fuel only. Field conversion kits are required for conversion to LP gas - refer to **Burner Kits** on the page listed below

PRICE INCLUDES BURNER KIT & REQUIRED TUBE KIT(S) FOR HEATER LENGTH:

BURNER KIT: S/S FLEXIBLE GAS CONNECTOR, ELECTRICAL CORD, STATUS INDICATOR LIGHTS, FACTORY MOUNTED IGNITER, FACTORY INSTALLED 24/120V RELAY SWITCH, DROP-DOWN SERVICE ACCESS, BIRDSCREENED AIR INTAKE WITH COLLAR ON BLOWER

OPTIONAL: WALL OR ROOF COMBUSTION AIR INTAKE CAP.

TUBE KIT: PRIMARY TUBE(S), SECONDARY TUBE(S) WITH EMISSIVE COATING, FOCUS SHIELD REFLECTORS, TWO END PLATE HANGERS, WEBBED HANGERS FOR TUBES & REFLECTORS, TUBE COUPLER(S) AND TURBULATOR(S).

Burner Kits, and tube kits are packaged separately and clearly labelled for ease of assembling orders and shipping

- Please order heater(s) by Burner Kit(s) + Tube Kit(s)

Field conversion kit required for LP fuel

- standard burner stocked in NG -

- see page T-14 -

HEATER & ACCESSORY SELECTION: previous page
BURNER & TUBE KIT CHART: next page
STS-JZ BURNER KITS: page T-14
STS-JZ TUBE KITS: page T-15
OPTIONAL ACCESSORIES: page T-14

premierSchwank Tube Heaters STS-JZ Series

BURNER & TUBE KIT ASSEMBLY CHART

ANSI Standards require the manufacturer to supply a flexible gas connector with a tube heater. The flexible gas connector is included in the Burner Kit.

Which tube kits assemble with a burner kit?

Use the chart below to determine:

- ✓ Available tube length for each firing rate
- ✓ Available tube kit & quantities for each burner kit

- 1) Select HEATER MODEL / INPUT
- 2) Order BURNER KIT
Includes Required Gas Connector
- 3) Order Quantity(s) of TUBE KIT(s)

Chain: $((\text{tube length}/10) + 2) \times \text{length at each suspension point}$
'S' hooks: $(\text{tube length}/10) \times 2 + 4$

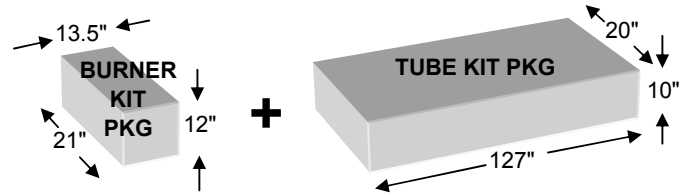

Stand-Alone tube kits require no additional tube kits.
Primary tube kits require at least one additional Secondary tube kit.
Secondary tube kit requires a Primary tube kit.

ORDER: BURNER KIT + TUBE KIT(s)

2. Order STS-JZ TUBE KIT PART # & QUANTITY REQUIRED

MODEL #	1. Order BURNER KIT Wt = 30 lb	Includes S/S Flex Gas Connector	Nominal Tube Length (ft)										
			Stand-Alone Kits					Primary Kits +		Secondary Kits			
			10'	20'	20'	30'	40'	30'	30'	20'	30'	40'	
			TS-4510-JZ	TS-1020-JZ	TS-1420-JZ	TS-1430-JZ	TS-1040-JZ	TS-F030-JZ	TS-1030-JZ	TS-0020-JZ	TS-0030-JZ	TS-0040-JZ	
STS-JZ 45	JS-S045-AN	1/2" x 24"	10'	1									
			20'		1								
STS-JZ 60	JS-S060-AN	1/2" x 24"	20'		1								
			30'			1							
STS-JZ 80	JS-S080-AN	1/2" x 24"	20'		1								
			30'			1							
STS-JZ 100	JS-S100-AN	1/2" x 24"	20'	1									
STS-JZ 110	JS-S110-AN	1/2" x 24"	30'			1							
			40'				1						
			50'					1+		1			
STS-JZ 130	JS-S130-AN	1/2" x 24"	30'			1							
			40'				1						
			50'					1+		1			
STS-JZ 155	JS-S155-AN	3/4" x 36"	40'				1						
			50'					1+		1			
			60'					1+			1		
STS-JZ 175	JS-S175-AN	3/4" x 36"	50'						1+	1			
			60'						1+		1		
			70'						1+			1	
STS-JZ 200	JS-S200-AN	3/4" x 36"	50'						1+	1			
			60'						1+		1		
			70'						1+			1	
				70	120	120	170	210	165	165	120	165	210

STS-JZ BURNER KITS: next page
STS-JZ TUBE KITS: page T-15
OPTIONAL ACCESSORIES: page T-19



premierSchwank Tube Heaters STS-JZ Series

BURNER KITS

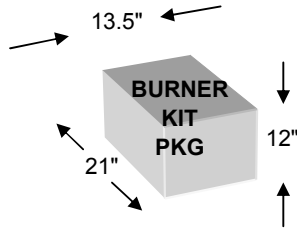

ANSI Standards require the manufacturer to supply a flexible gas connector with a tube heater. The flexible gas connector is included in the Burner Kit.

BURNER KITS ARE STOCKED IN NATURAL GAS - FIELD CONVERSION KITS FOR LP ARE LISTED BELOW**

BURNER INCLUDES: S/S FLEXIBLE GAS CONNECTOR, STATUS INDICATOR LIGHTS, ELECTRICAL CORD & PLUG, MOUNTED IGNITER, BIRDSCREENED 4" DIAMETER AIR INTAKE ADAPTER ON BLOWER.

<u>CAPACITY</u>	<u>AVAILABLE TUBE LENGTHS</u>	<u>FUEL</u>	<u>INCLUDES FLEX GAS CONNECTOR</u>	<u>PART #</u>	<u>LIST PRICE*</u>
45,000 Btuh	10', 20'	N.G.	1/2" X 24"	JS-S045-AN	856.00
60,000 Btuh	20', 30'	N.G.	1/2" X 24"	JS-S060-AN	856.00
80,000 Btuh	20', 30', 40'	N.G.	1/2" X 24"	JS-S080-AN	856.00
100,000 Btuh	20'	N.G. ONLY	1/2" X 24"	JS-S100-AN	856.00
110,000 Btuh	30', 40', 50'	N.G.	1/2" X 24"	JS-S110-AN	856.00
130,000 Btuh	30', 40', 50'	N.G.	1/2" X 24"	JS-S130-AN	856.00
155,000 Btuh	40', 50', 60'	N.G.	3/4" X 36"	JS-S155-AN	925.00
175,000 Btuh NG	50', 60', 70'	N.G.	3/4" X 36"	JS-S175-AN	956.00
NOTE**: 175,000 Btuh LP	50', 60', 70'	L.P.	3/4" X 36"	JS-S175-AL	956.00
200,000 Btuh	50', 60', 70'	N.G.	3/4" X 36"	JS-S200-AN	956.00

** NOTE: Order 175,000 Btuh Propane burner direct from factory; Product Bulletins provide detail on 175,000 burner conversion

Burner kit contains: Burner assembly, S/S FLEXIBLE Gas Connector, installation manual; the burner fastening nuts & bolts are packed inside the burner housing. All optional accessories are shipped in separate carton.

All burner assemblies operate on line voltage (120VAC).

Heaters are shipped and invoiced separately as burner kits and tube kits

Please order heaters as burner kits + tube kits

LPG FIELD CONVERSION KITS FOR STS-JZ BURNERS

Conversion Kits for LP to NG are listed on page 62

<u>INPUT</u>		<u>PART #</u>	<u>LIST PRICE*</u>
45,000 Btuh	Field Conversion Kit NG to LP	JS-0556-XC	\$ 46.40
60,000 Btuh	Field Conversion Kit NG to LP	JS-0557-XX	24.80
80,000 Btuh	Field Conversion Kit NG to LP	JS-0559-XX	24.80
100,000 Btuh	Available in NG ONLY		
110,000 Btuh	Field Conversion Kit NG to LP	JS-0561-XX	24.80
130,000 Btuh	Field Conversion Kit NG to LP	JS-0563-XX	24.80
155,000 Btuh	Field Conversion Kit NG to LP	JS-0565-XX	24.80
175,000 Btuh	Field Conversion Kit NG to LP**	JS-0567-AA	24.80
200,000 Btuh	Field Conversion Kit NG to LP	JS-0567-CC	24.80

** See NOTE above

BURNER & TUBE KIT CHART: previous page
STS-JZ TUBE KITS: next page
OPTIONAL ACCESSORIES: page T-19



premierSchwank Tube Heaters STS-JZ Series

TUBE KITS (emissive coated)

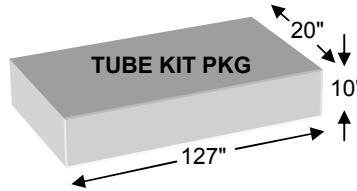

FEATURES of the '-JZ' Tube System:

- Webbed hanger joins reflectors - *replaces wire and multi-piece plate hangers*
- Fewer suspension points than 'wire hangers', and no plate hanger assembly
- 'Clean' reflector profile - No extra-piece reflector 'slides' or joiners
- Modular 90° elbow kit with reflector cover ~ simply combine two 90's to make a 180

Stand-Alone tube kits require no additional tube kits.

Primary tube kits require at least one additional Secondary tube kit.

Secondary tube kit require a Primary tube kit.

Chain: $((\text{tube length}/10) + 2) \times \text{length at each suspension point}$
'S' hooks: $(\text{tube length}/10) \times 2 + 4$

Kits include Tubes, Reflectors, End Caps, Hangers, Tube Couplers and Turbulator(s) as required

<u>Stand-Alone</u>	(Each kit includes 'JZ' 116" Reflectors, WEBBED Hanger System, Couplers)	<u>TUBE KIT #</u>	<u>LIST PRICE</u>
10' : 45,000 Btuh	One flanged/swaged emissive coated aluminized tube with no ports, one 5 ft turbulator	TS-4510-JZ	\$ 442.00
20' : 45/60/80,000	One flanged/swaged aluminized tube with no ports, one emissive coated steel swaged tube, one 4 ft turbulator and one 10 ft turbulator	TS-1420-JZ	566.00
20' : 100,000 ONLY	One flanged/swaged Aluminized emissive coated tube with no ports, one emissive coated steel swaged tube, one 10 ft S/S turbulator	TS-1020-JZ	659.00
30' : 60/80/110/130,000	One flanged/swaged aluminized tube with no ports, two emissive coated steel swaged tubes, one 4 ft turbulator and one 10 ft turbulator	TS-1430-JZ	762.00
40' : 80/110/130/155,000	One flanged/swaged aluminized tube with no ports, three emissive coated steel swaged tubes, and one 10 ft turbulator	TS-1040-JZ	957.00

Primary Kits [require a Secondary Kit to make (40'), 50', 60' & 70' heaters]

30' : 110/130/155,000	One flanged/swaged aluminized tube with no ports, two emissive coated steel swaged tubes	TS-F030-JZ	751.00
30' : 175/200,000	One flanged/swaged alumatherm tube with no ports, one aluminized swaged tube, one emissive coated steel swaged tube, one 10 ft turbulator	TS-1030-JZ	823.00

Secondary Kits [add to above Primary Kits to make (40'), 50', 60' & 70' heaters]

20'	Two emissive coated steel swaged tubes (makes 50' heater with 30' primary)	TS-0020-JZ	484.00
30'	Three emissive coated steel swaged tubes (makes 60' heater with 30' primary)	TS-0030-JZ	679.00
40'	Four emissive coated steel swaged tubes (makes 70' heater with 30' primary)	TS-0040-JZ	875.00
10'	One emissive coated steel swaged tube, and one 10 ft turbulator	TS-1010-JZ	319.00

Do not use the 10 ft tube kit to extend heater length beyond the maximum length approved for any input.
 Secondary tube kit TS-1010-JZ can be used with TS-F030-JZ to create a 40 ft kit.

BURNER & TUBE KIT CHART: page T-13
STS-JZ BURNER KITS: page T-14
OPTIONAL ACCESSORIES: page T-19



premierSchwank Tube Heaters STV-JZ Vacuum Series

(Single Tube - emissive coated)

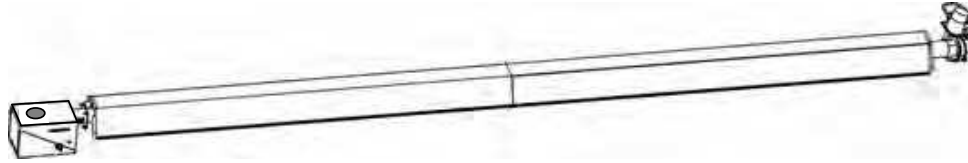

COMPLETE SYSTEMS:

MODEL	CAPACITY	Fuel	AVAILABLE TUBE		LIST PRICE
			LENGTHS		
STV-JZ 60	60,000 Btuh	NG	20'	\$	1,974.00
			30'		2,170.00
STV-JZ 80	80,000 Btuh	NG	30'		2,170.00
			40'		2,365.00 *
STV-JZ 110	110,000 Btuh	NG	40'		2,365.00 *
			50'		2,643.00
STV-JZ 130	130,000 Btuh	NG	40'		2,365.00 *
			50'		2,643.00
STV-JZ 155	155,000 Btuh	NG	50'		2,712.00
			60'		2,907.00

**Burner kit + tube kit(s) + vacuum pump kit
are shipped to assemble tube
heater orders.**

~ See next page for details ~

* 40 ft heater price based on
TS-1040-JZ Tube Kit

NOTE:

Standard burners are stocked for
natural gas fuel only.
Field conversion kits are required
for conversion to LP gas -
refer to **Burner Kits**
on the page listed below

PRICE INCLUDES BURNER ASSEMBLY AND THE FOLLOWING COMPONENTS AS REQUIRED:

BURNER KIT: S/S FLEXIBLE GAS CONNECTOR, ELECTRICAL CORD, STATUS INDICATOR LIGHTS, FACTORY MOUNTED IGNITER, FACTORY INSTALLED 24/120V RELAY SWITCH, DROP-DOWN SERVICE ACCESS, BIRDSCREENED 4" DIAMETER AIR INTAKE ADAPTER ON BURNER.; VACUUM PUMP KIT;

TUBE KIT: PRIMARY TUBE(S), SECONDARY TUBE(S) WITH EMISSIVE COATING, TUBE COUPLER(S) AND TURBULATOR(S), FOCUS SHIELD REFLECTORS, TWO END PLATE HANGERS, WEBBED HANGERS FOR TUBES & REFLECTORS,

Burner with accessories, and the reflectors with tubes and accessories are packaged separately and clearly labelled for ease of filling orders and shipping

KIT ASSEMBLY CHART: next page
STV-JZ BURNER KITS: next page
VACUUM PUMPS: next page
STV-JZ TUBE KITS: page T-18
OPTIONAL ACCESSORIES: page T-19



premierSchwank Tube Heaters STV-JZ Vacuum Series

BURNER, TUBE & VACUUM PUMP KIT ASSEMBLY CHART

MODEL	Order KIT Gross Wt = 25 lb	BURNER	INCLUDES S/S FLEXIBLE Gas Connector	Order PUMP Kit	VAC.	STSV-JZ TUBE KIT PART # & QUANTITY REQUIRED					
						Stand-Alone			Primary	+ Secondary Kits	
						120	170	210	165	120	165
						20'	30'	40'	30'	20'	30'
						TS-1420-JZ	TS-1430-JZ	TS-1040-JZ	TS-F030-JZ	TS-0020-JZ	TS-0030-JZ
STV-JZ 60	JS-V060-BN	1/2" X 24"	1/2" X 24"	JS-V060-PM	20'	1					
					30'		1				
STV-JZ 80	JS-V080-BN	1/2" X 24"	1/2" X 24"	JS-V080-PM	30'		1				
					40'						
STV-JZ 110	JS-V110-BN	1/2" X 24"	1/2" X 24"	JS-V110-PM	40'			1			
					50'				1+	1	
STV-JZ 130	JS-V130-BN	1/2" x 24"	1/2" x 24"	JS-V110-PM	40'			1			
					50'				1+	1	
STV-JZ 155	JS-V155-BN	3/4" x 36"	3/4" x 36"	JS-V110-PM	50'				1+	1	
					60'				1+		1

USA: S/S FLEXIBLE Gas Connectors for Tube Heaters

Note: Minimum length for tube heater flexible connector is 24 inches.

By ANSI Standard the Flexible Gas Connector is now supplied by the manufacturer and is required to be installed at the site.

STV-JZ BURNER KITS: ALSO REQUIRES VACUUM PUMP KIT BELOW

CAPACITY	AVAILABLE TUBE LENGTHS	FUEL	INCLUDES FLEX GAS CONNECTOR	Burner Kit PART #	LIST PRICE
60,000 Btuh	20', 30'	N.G.	1/2" X 24"	JS-V060-BN	\$ 875.00
80,000 Btuh	30', 40'	N.G.	1/2" X 24"	JS-V080-BN	875.00
110,000 Btuh	40', 50'	N.G.	1/2" X 24"	JS-V110-BN	875.00
130,000 Btuh	40', 50'	N.G.	1/2" X 24"	JS-V130-BN	875.00
155,000 Btuh	50', 60'	N.G.	3/4" X 36"	JS-V155-BN	944.00

STV-JZ VACUUM PUMP KITS

Vacuum Pump Kit for STV-JZ-60	JS-V060-PM	\$ 533.00
Vacuum Pump Kit for STV-JZ-80	JS-V080-PM	533.00
Vacuum Pump Kit for STV-JZ-110 / 130 / 155	JS-V110-PM	533.00

STV-JZ COMPLETE SYSTEMS: previous page

STV-JZ TUBE KITS: next page

OPTIONAL ACCESSORIES: page T-19

LPG FIELD CONVERSION KITS FOR STV-JZ BURNERS

INPUT		PART #	LIST PRICE*
60,000 Btuh	Field Conversion Kit NG to LP	JS-0557-XX	\$ 24.80
80,000 Btuh	Field Conversion Kit NG to LP	JS-0559-XX	24.80
110,000 Btuh	Field Conversion Kit NG to LP	JS-0561-XX	24.80
130,000 Btuh	Field Conversion Kit NG to LP	JS-0563-XX	24.80
155,000 Btuh	Field Conversion Kit NG to LP	JS-0565-XX	24.80

premierSchwank Tube Heaters STV-JZ Vacuum Series

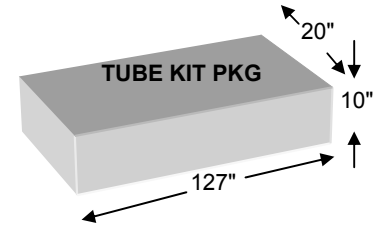

TUBE KITS (emissive coated)

Stand-Alone tube kits require no additional tube kits.
Primary tube kits require at least one additional Secondary tube kit.
Secondary tube kit require a Primary tube kit.

Chain: $((\text{tube length}/10) + 2) \times \text{length at each suspension point}$
'S' hooks: $(\text{tube length}/10) \times 2 + 4$

Stand-Alone	'-JZ' Tube Kits include 116" reflectors, webbed hangers, and tube couplers	TUBE KIT #	LIST PRICE*
20' : 60,000	One flanged/swaged aluminized tube with no ports, one emissive coated steel swaged tube, one 4 ft turbulator and one 10 ft turbulator	TS-1420-JZ	\$ 566.00
30' : 60/80,000	One flanged/swaged aluminized tube with no ports, two emissive coated steel swaged tubes, one 4 ft turbulator and one 10 ft turbulator	TS-1430-JZ	\$ 762.00
40' : 80/110/130,000	One flanged/swaged aluminized tube with no ports, three emissive coated steel swaged tubes, and one 10 ft turbulator	TS-1040-JZ	\$ 957.00
Primary Kits [to make (40'), 50', 60' & 70' heaters]			
30' : 110/130/155,000	One flanged/swaged aluminized tube with no ports, two emissive coated steel swaged tubes	TS-F030-JZ	751.00
Secondary Kits [add to above Primary Kits to make (40'), 50', 60' & 70' heaters]			
10'	One emissive coated steel swaged tube, and one 10 ft turbulator	TS-1010-JZ	319.00
20'	Two emissive coated steel swaged tubes	TS-0020-JZ	484.00
30'	Three emissive coated steel swaged tubes	TS-0030-JZ	679.00

COMPLETE STV-JZ SYSTEMS: page T-16
STV-JZ BURNER, VACUUM PUMP & TUBE
KIT ASSEMBLY CHART: previous page
OPTIONAL ACCESSORIES: next page



OPTIONAL ACCESSORIES - Page 1 of 4

UHE, STS-JZ, STV-JZ TUBE HEATERS

More Options: Next pages.

Thermostats: 4th Page



IMPORTANT: TUBE HEATER GAS CONNECTION - JUNE 2009

ANSI Z83.20-2008 / CSA 2.34-2008

New Standard for Gas-Fired Low-Intensity Infrared Tube Heaters

requires the mandatory supply of specific gas connector by the manufacturer:

USA : A S/S FLEXIBLE Gas Connector IS SUPPLIED with Tube Heater:

Note: Minimum length for tube heater flexible connector is 24 inches.

Refer to table below for correct sized connector that is supplied and must be installed.

Gas connector is shipped in the Burner Kit carton

Mandatory S/S Flex Gas Connector	
Input Btuh	Required ID x Length
45,000	1/2" x 24"
60,000	1/2" x 24"
80,000	1/2" x 24"
100,000	1/2" x 24"
110,000	1/2" x 24"
130,000	1/2" x 24"
155,000	3/4" x 36"
175,000	3/4" x 36"
200,000	3/4" x 36"

Flexible Gas Connectors:

S/S FLEXIBLE - Replacement Parts

S/S FLEXIBLE Connector 1/2" X 24" - for 45,000 up to 130,000 Btuh
JL-0771-XX \$33.00

S/S FLEXIBLE Connector 3/4" x 36" - for 155,000 up to 200,000 Btuh
JL-0771-YY 102.00

Hanging Chain:

UHE & Other Series: #2 Lion Chain - 115 lb work load - 200 ft roll



PART #

LIST PRICE

JL-0800-XX

\$97.00

'-JZ' Series Only: #8 Jack Chain - 60 lb work load - 50 ft box



JL-0798-JC

60.00

Quantity of Chain required: { UHE Series heater = ((heater tube length/10) x 2) + 1) x length of chain at each suspension point
-JZ Series heater = ((heater tube length/10) + 2) x length of chain at each suspension point

Safety Snap Hooks - 2"



Package of 24

JL-0800-SH

40.20

Package of 100

JL-0800-SH-B

123.00

'S' Hooks - 1 7/8" - Package of 25

JL-0798-SH

23.20

Quantity of 'Snap' or 'S' Hooks: { UHE Series quantity required = ((tube length/10) x 4) + 2 : ie: UHE x 40 ft = (40/10) x 4) + 2 = 18 hooks
-JZ Series quantity required = ((tube length/10) x 2) + 4 : ie: SPW-JZ x 40 ft = (40/10) x 2) + 4 = 12 hooks

CLEARANCE TO COMBUSTIBLES SIGN

Metal sign - 18" x 6"
- 3/4" red lettering on white background



JL-0798-CS

37.10

OPTIONAL ACCESSORIES - Page 2 of 4

UHE, STS-JZ, STV-JZ TUBE HEATERS

More Options: Next page.
Thermostats: Page after next.

Combustion Air Intake Hood: *Optional*

Not all tube heater applications require outside air for combustion.

Schwank recommends outside combustion air for conditions:

- A building under negative air condition
- Dusty environment in the building
- Presence of chemical or process contaminants such as welding smoke
- Sealed combustion is required or advised for the project



Wall Hood



Roof Cap

STS-JZ & STV-JZ models are shipped with a 4" diameter collar on top of the blower or burner for vent attachment.

Outside combustion air can be acquired from an outside wall or from the roof using 4" diameter vent pipe.

Please refer to the installation manual for complete details on venting and combustion air duct.

	<u>PART #</u>	<u>LIST PRICE</u>
4" Outside Air Intake Wall Vent Hood ~ birdscreened, flush mount	JS-0532-VC	\$ 26.70
4" Roof Cap - fits single wall vent/duct	JA-0530-XX	48.00

Vent Stuff:



Wall Terminal*

Flue Vent Terminals:

	<u>PART #</u>	<u>LIST PRICE</u>
4" horizontal (through wall)	JA-0528-XX	\$ 39.50
6" horizontal	JA-0529-XX	48.00

Use this termination cap by Schwank, or use the termination cap for double walled pipe as supplied by that manufacturer

* Fits single wall vent pipe - field crimp required to fit to double wall pipe

Vent Tee 4" X 4" X 6"
(Two couplers JA-0516-AA are optional)



4" x 4" x 6"
Vent Tee

JA-0514-XX 197.00

Optional Couplers for Vent Tee:

4" x 8" Aluminized Steel Coupler with 2 x U-bolts JA-0516-AA 41.70



OPTIONAL ACCESSORIES - Page 3 of 4

STS-JZ, STV-JZ TUBE HEATERS (THESE ITEMS NOT FOR UHE SERIES)

ST-JZ Elbow Kits:

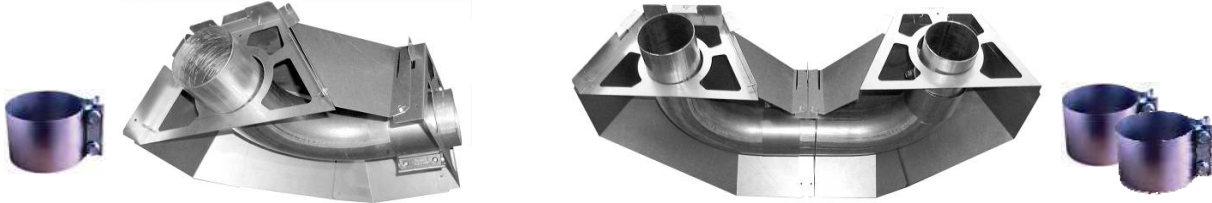

ST-JZ 90° Aluminized Steel Elbow & Reflector Cover Kit: JS-0508-JZ \$ 160.00
(Elbow can be installed right or left hand - Includes coupler, reflector cover, hanger plate)

ST-JZ 180° Elbow & Reflector Cover Kit: ORDER: TWO x 90° ELBOW KITS Qty 2 x JS-0508-JZ 320.00

➔ **Reflector Angle Adapter** - one required each juncture of angle change JS-0504-JZ \$ 15.60

NOTE: The elbow reflector cap must always be in the same plane as the elbow - cap cannot be angled independently
The Reflector Angle Adapter is required for angle mounting a reflector section before or after an elbow
Or for mounting of a reflector section at an independent angle relative to the other reflectors in the system.

Other Optional Accessories:

Decorative 'Tuxedo' Grille Kit - Matte Black finish

Dress up your tube heater installations.

- Ideal for:
- Showrooms
 - Retail areas
 - Any area requiring a more refined 'look'



Matte black grille & aluminized steel framing secures with tabs to 'JZ' Series heater reflectors. (Not for S100 Series)

Decorative 'Tuxedo' Grille Kit - 10 ft - Matte Black Grille *Each 10 foot section* TG-0010-KT \$ 360.00

Reflector Side Extension Extension

- All models - 10" deep x 116" long c/w Qty 3 x 'S' hooks JS-0509-KT 47.00

Tube Protection Screen - STS-JZ - 5 ft length

(1/2" x 1/2" galvanized screen)
(custom order: longer lead time)

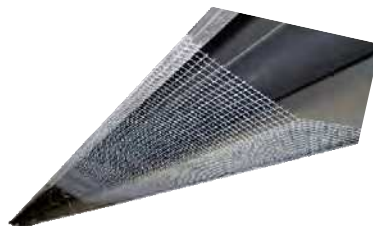

JA-0780-XX 60.00

THERMOSTATS & CONTROL OPTIONS on next page



OPTIONAL ACCESSORIES - Page 4 of 4

UHE, STS-JZ & STV-JZ THERMOSTATS & CONTROLS

STS-JZ, STV-JZ, STW-JZ & SPW-JZ tube heaters are "factory ready" for line voltage or 24V thermostat;

Multiple heaters per 24 volt thermostat require option JM-0303-KT (see below)

Heaters manufactured prior to May 1, 2006 require 24V Field Mounted Kit for 24V control

ThermoControl Plus
- Building Management System
(°F & °C scales)



See more info on the
ThermoControl Plus on
pages T-58 & T-59

TruTemp Infrared Setback Thermostat
(°F & °C scales)
(see more info on the TruTemp on page T-60)



JM-0150-XX 213.00

Line Voltage Thermostat
(°F & °C Scales)



JL-0772-XX 39.50

Low Voltage (24V) Digital Thermostat
(°F / °C Selectable)



JS-0569-WR 66.00

Moisture Proof Thermostat (NEMA 4X enclosure)

JS-0570-XX 341.00

24 VOLT CONTROL OPTIONS:

(Required for multiple heaters per TruTemp or 24V Digital Thermostat) Refer to guidelines page T-61

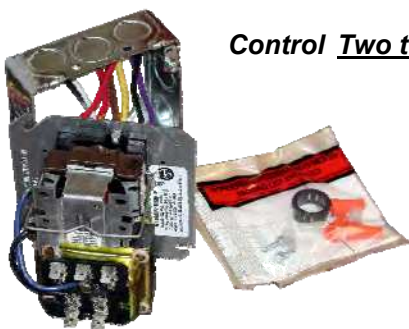

Control Two to Seven Tube Heaters per 24V Thermostat:

24V Transformer/Relay Kit JM-0303-KT 107.00

FIELD MOUNTS ON EXTERIOR
BURNER HOUSING OF
ONE HEATER IN ZONE

ST- Series Burners prior to May 1, 2006:

For control of heaters manufactured prior to May 1, 2006,
the ST-series 24V Field Mounted Kit is required for 24V thermostat control:

For Single STS-JZ: ST-series 24V Field Mounted Kit (see note in line above)
(Single heater per thermostat)



JS-0568-KT \$ 37.40

SP-LTUB-IX-01A
RD: APR 2011
RL:USA - 11-1A
BA



builderSchwank Tube Heaters S100 & S100U Series

HEATER & ACCESSORY SELECTION CHART

S100 SERIES: 24V GAS VALVE & IGNITION CONTROL

S100 SERIES IS STOCKED IN NATURAL GAS ONLY
CONVERSION KIT REQUIRED FOR LP GAS
(SEE DETAILS IN PRICE PAGES)

S100(U) BURNER KITS

45,000	S100 45	JS-E045-BN
60,000	S100 60	JS-E060-BN
80,000	S100 80	JS-E080-BN
100,000	S100 100	JS-E100-BN
110,000	S100 110	JS-E110-BN
130,000	S100 130	JS-E130-BN
155,000	S100 155	JS-E155-BN
175,000	S100 175	JS-E175-BN
200,000	S100 200	JS-E200-BN

SELECT ONE TYPE OF TEMPERATURE CONTROL DEPENDING ON VOLTAGE AND QUANTITY OF THERMOSTAT(S) REQUIRED

NOTE: WHEN TWO HEATERS ARE COMMON VENTED, BOTH HEATERS MUST BE CONTROLLED BY THE SAME THERMOSTAT

EITHER

LINE VOLTAGE THERMOSTAT

JL-0772-XX

CALL FOR HEAT POWERS HEATER

THERMOSTAT NOT INCLUDED WITH HEATER

OR

24 VOLT THERMOSTAT JS-0569-WR

REQUIRES 24 VOLT TRANSFORMER/ RELAY OR RELAY KIT, TO POWER 24 VOLT THERMOSTAT;
CALL FOR HEAT POWERS RELAY

OR

TRU-TEMP THERMOSTAT (24V)

JM-0150-XX

AUTO SET-BACK; SENSES AMBIENT AND RADIANT TEMPERATURES FOR OPTIMUM ENERGY SAVINGS & COMFORT
CALL FOR HEAT POWERS RELAY

FOR SINGLE S100 PER 24V THERMOSTAT

ONE THERMOSTAT CONTROLS ONE HEATER
S100 24V/120V RELAY KIT JS-0568-KT
24V THERMOSTAT
OR TRU-TEMP THERMOSTAT:
THERMOSTAT NOT INCLUDED IN KIT

AND

EITHER

OR

FOR 2 to 7 S100 PER 24V THERMOSTAT

TRANSFORMER / RELAY KIT JM-0303-KT
THERMOSTAT CONTROLS 2 to 7 HEATERS
REQUIRED WITH 24 VOLT THERMOSTAT
OR TRU-TEMP THERMOSTAT
THERMOSTAT NOT INCLUDED IN RELAY KIT

AND

TUBE KIT(S) See larger detail in Price Pages

BURNER KIT FIRING RATE	Heater Tube Length	STRAIGHT TUBE KIT PART # & QUANTITY REQUIRED									
		Stand-Alone Kits					Primary Kits		Secondary Kits		
		TM-4510-SX	TM-4520-SX	TM-1020-SX	TM-1420-SX	TM-1430-SX	TM-1040-SX	TM-F030-SX	TM-1030-SX	TM-0020-SX	TM-0030-SX
45,000	10'	1									
	20'		1								
60,000	20'				1						
	30'					1					
80,000	20'				1						
	30'					1					
100,000	20'			1							
	30'					1					
110,000	30'					1					
	40'						1+			1	
130,000	30'					1					
	40'						1+			1	
155,000	40'					1					
	50'						1+			1	
175,000	50'						1+		1+	1	1
	60'						1+		1+	2	1
200,000	50'						1+		1+	1	1
	60'						1+		1+	2	1
	70'						1+		1+	2	1

AND

SINGLE HEATER VENT TERMINATION CAP

4" Horizontal Wall Cap JA-0528-XX
OR 4" Roof Vent Cap JA-0530-XX

AND OPTIONAL ITEMS

Fresh Air Intake Adapter

JS-0532-SE

Fresh Air Intake Hood

JS-0532-VC

4" X 4" X 6" TEE

JA-0514-XX

Used for:
COMMON VENTING
of TWO Systems
Requires common
Thermostat

50' JACK CHAIN KIT

JL-0798-JC

Number Suspension Points:
= (Heater Length ÷ 10) x 2
i.e.: 50' Heater = (50/10) x 2 = 10

S' HOOKS - Pkg of 25

JL-0798-SH

6" Horizontal Wall Cap JA-0529-XX
OR 6" Roof Vent Cap JA-0531-XX



builderSchwank Tube Heaters S100 & S100U Series

(Single Straight Tube - NOT emissive coated)

(Tube kits for S100-45-10' & S100-100-20' have emissive coating)



S100 FEATURES SUMMARY:

- Line voltage thermostat ready
- Simple relay option for 24V thermostat
- Reflector & end caps improve IR heat output
- Swing-down cabinet service access
- Whisper quiet ceramic burner

COMPLETE SYSTEMS:

MODEL	CAPACITY		AVAILABLE TUBE		LIST PRICE
			LENGTH		
S100 45	45,000 Btuh	NG	10'	\$	1,174.00
			20'		1,228.00
S100 60	60,000 Btuh	NG	20'		1,228.00
			30'		1,366.00
			20'		1,228.00
S100 80	80,000 Btuh	NG	30'		1,366.00
			40'		1,505.00 *
S100 100	100,000 Btuh	NG Only	20'		1,366.00
			30'		1,366.00
S100 110	110,000 Btuh	NG	40'		1,505.00 *
			50'		1,749.00
			30'		1,366.00
S100 130	130,000 Btuh	NG	40'		1,505.00 *
			50'		1,749.00
			40'		1,574.00 *
S100 155	155,000 Btuh	NG	50'		1,818.00
			60'		1,965.00
			50'		1,946.00
S100 175	175,000 Btuh	NG	60'		2,093.00
			70'		2,242.00
			50'		1,946.00
S100 200	200,000 Btuh	NG	60'		2,093.00
			70'		2,242.00

**Individual burner kits + tube kits
are shipped to assemble tube
heater orders.
~ See next page for details ~**

* 40 ft heater price based on
TM-1040-SX Tube Kit

NOTE:
Standard burners are stocked for
natural gas fuel only.
Field conversion kits are required for
conversion to LP gas -
refer to **Burner Kits**
on the page listed below

PRICES INCLUDE BURNER ASSEMBLY AND THE FOLLOWING COMPONENTS AS REQUIRED:

TUBE KIT: PRIMARY & SECONDARY TUBE(S), REFLECTORS, TWO REFLECTOR END CAPS, WIRE REFLECTOR/TUBE HANGERS, TUBE COUPLER(S), AND TURBULATOR(S)

BURNER KIT: S/S FLEXIBLE GAS CONNECTOR, BIRDSCREEN ON BLOWER, IGNITER (FIELD MOUNT IN 1st TUBE).

OPTIONAL: FRESH AIR INTAKE ADAPTER & WALL HOOD or ROOF CAP

Burner with accessories, and the reflectors, tubes and accessories are packaged separately and clearly labelled for ease of filling orders and shipping

All optional accessories are shipped in a separate carton.

*Please Order Heaters as burner kits +tube kit(s)
Heaters are shipped and invoiced as burner kits and tube kits*

Heater & Accessory Selection Chart: Previous Page
BURNER & TUBE KIT CHART: Next Page
S100 BURNER KITS: Page 26
S100 TUBE KITS: Page 27
OPTIONAL ACCESSORIES: Page 38 - 40

builderSchwank Tube Heaters S100 Series

BURNER & TUBE KIT* ASSEMBLY CHART

Which tube kits assemble with a burner kit?

Use the chart below to determine:

- ✓ Available tube length for each firing rate
 - ✓ Available tube kit & quantities for each burner kit
- 1) Select HEATER MODEL
 - 2) Order BURNER KIT
 - 3) Order Quantity(s) of TUBE KIT(s)

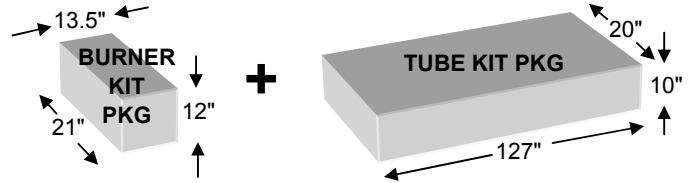

Chain: ((tube length/10) x 2 + 1) x length
at each suspension point
'S' hooks: (tube length/10) x 4 + 2

Stand-Alone tube kits require no additional tube kits.
Primary tube kits require at least one additional Secondary tube kit.
Secondary tube kit require a Primary tube kit.

			S100 TUBE KIT PART # & QUANTITY REQUIRED									
			Stand-Alone Kits					Primary Kits		+ Secondary Kits		
			80	120	120	170	210	165	165	120	165	210
			10'	20'	20'	30'	40'	30'	30'	20'	30'	40'
MODEL S100 INPUTS (Btuh)	BURNER KIT (Includes S/S Flex Gas Connector) Gross Wt = 30 lbs	Nominal Tube Length (ft)	TM-4510- SX	TM-1020- SX	TM-1420- SX	TM-1430- SX	TM-1040- SX	TM-F030- SX	TM-1030- SX	TM-0020- SX	TM-0030- SX	TM-0040- SX
45,000	JS-E045-BN	10'	1									
		20'			1							
60,000	JS-E060-BN	20'			1							
		30'				1						
80,000	JS-E080-BN	20'			1							
		30'				1						
100,000	JS-E100-BN	20'		1								
		30'				1						
110,000	JS-E110-BN	40'					1					
		50'						1+		1		
130,000	JS-E130-BN	30'				1						
		40'					1					
155,000	JS-E155-BN	50'						1+		1		
		60'						1+			1	
175,000	JS-E175-BN	50'							1+	1		
		60'							1+		1	
200,000	JS-E200-BN	70'							1+			1
		50'							1+	1		
		60'							1+		1	
		70'							1+			1

*NOTE: S100 Series tubes are NOT emissive coated (except 10' x 45,000 & 20' x 100,000 Btuh tubes are emissive coated)

COMPLETE SYSTEMS: previous page
S100 TUBE KITS: next page
S100 BURNER KITS: page T-26
OPTIONAL ACCESSORIES: page T-38 - 40



builderSchwank Tube Heaters S100 Series

BURNER KITS

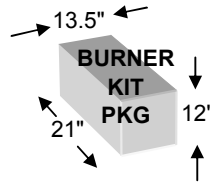

A flexible gas connector is now required to be supplied by the manufacturer with a tube heater. It is now included with the Burner Kit.

BURNER KITS ARE STOCKED IN NATURAL GAS - FIELD CONVERSION KITS FOR LP ARE LISTED BELOW**

INPUT	AVAILABLE	FUEL	INCLUDES	PART #	LIST PRICE*
	TUBE LENGTHS		FLEX GAS CONNECTOR		
45,000 Btuh	10', 20'	N.G.	1/2" X 24"	JS-E045-BN	737.00
60,000 Btuh	20', 30', 10'U	N.G.	1/2" X 24"	JS-E060-BN	737.00
80,000 Btuh	20', 30', 40', 10'U	N.G.	1/2" X 24"	JS-E080-BN	737.00
100,000 Btuh	20'	N.G. ONLY	1/2" X 24"	JS-E100-BN	737.00
110,000 Btuh	30', 40', 50', 15'U, 20'U	N.G.	1/2" X 24"	JS-E110-BN	737.00
130,000 Btuh	30', 40', 50', 15'U, 20'U	N.G.	1/2" X 24"	JS-E130-BN	737.00
155,000 Btuh	40', 50', 60', 20'U, 30'U	N.G.	3/4" X 36"	JS-E155-BN	806.00
175,000 Btuh	50', 60', 70', 30'U	N.G.	3/4" X 36"	JS-E175-BN	838.00
NOTE**: 175,000 Btuh LP	50', 60', 70', 30'U	L.P.	3/4" X 36"	JS-E175-BL	838.00
200,000 Btuh	50', 60', 70', 30'U	N.G.	3/4" X 36"	JS-E200-BN	838.00

** Order 175,000 Btuh Propane burner direct from factory; Product Bulletins provide detail on 175,000 burner conversion

The following items are packed inside the burner assembly carton: S/S Flexible Gas Connector, burner fastening nuts, igniter, installation manual.

All S100 series burner assemblies operate on line voltage (120VAC).

For 24V control of S100 Series Heaters, see Optional Accessories and refer to ' 24V Guidelines' page T-61

Please order heaters as burner kits +tube kit(s)

Heaters are shipped and invoiced as burner kits and tube kits

LPG FIELD CONVERSION KITS FOR S100 BURNERS

INPUT		PART #	LIST PRICE*
45,000 Btuh	Field Conversion Kit NG to LP	JS-0556-XE	\$ 36.10
60,000 Btuh	Field Conversion Kit NG to LP	JS-0557-XX	24.80
80,000 Btuh	Field Conversion Kit NG to LP	JS-0559-XX	24.80
100,000 Btuh	Available in NG ONLY		
110,000 Btuh	Field Conversion Kit NG to LP	JS-0561-XX	24.80
130,000 Btuh	Field Conversion Kit NG to LP	JS-0563-XX	24.80
155,000 Btuh	Field Conversion Kit NG to LP	JS-0565-XX	24.80
175,000 Btuh	Field Conversion Kit NG to LP**	JS-0567-AA	24.80
200,000 Btuh	Field Conversion Kit NG to LP	JS-0567-CC	24.80

Conversion Kits for LP to NG are listed on page T-62

**See NOTE above

S100 SYSTEMS: page T-24
S100 KIT ASSEMBLY CHART: page T-25
S100U SYSTEMS: next page
S100U KIT ASSEMBLY CHART: page T-29
OPTIONAL ACCESSORIES: page T-38 - 40



builderSchwank Tube Heaters S100 Series

TUBE KITS (NOT emissive coated*) for STRAIGHT RUN TUBE HEATERS

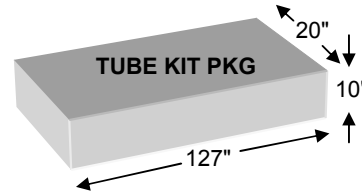

* Tubes for the 10 ft x 45,000 & 20 ft x 100,000 Btuh heaters are emissive coated

Stand-Alone tube kits require no additional tube kits.

Primary tube kits require at least one additional Secondary tube kit.

Secondary tube kit require a Primary tube kit.

Chain: $((\text{tube length}/10) \times 2 + 1) \times \text{length}$
at each suspension point
'S' hooks: $(\text{tube length}/10) \times 4 + 2$

Kits include Tubes, Reflectors, End Caps, Hangers, and Tube Couplers

<u>Stand-Alone</u>	<u>Description</u>	<u>TUBE KIT #</u>	<u>LIST PRICE</u>
10' : 45,000 ONLY	One flanged/swaged aluminized emissive coated tube with sight glass and igniter ports, and one 5 ft turbulator	TM-4510-SX	\$ 437.00
20' : 45/60/80,000	One flanged/swaged aluminized tube with sight glass and igniter ports, one steel swaged tube, one 4 ft turbulator and one 10 ft turbulator	TM-1420-SX	491.00
20' : 100,000 ONLY	One flanged/swaged aluminized emissive coated tube with sight glass and igniter ports, one steel swaged emissive coated tube, and one 10 ft S/S turbulator	TM-1020-SX	629.00
30' : 60/80/110/130,000	One flanged/swaged aluminized tube with sight glass and igniter port, two steel swaged tubes, one 4 ft turbulator and one 10 ft turbulator	TM-1430-SX	629.00
40' : 80/110/130/155,000	One flanged/swaged aluminized tube with sight glass and igniter port, three steel swaged tubes, one 10 ft turbulator	TM-1040-SX	768.00
Primary Kits [to make (40'), 50', 60' & 70' heaters]			
30' : 110/130/155,000	One flanged/swaged aluminized tube with sight glass and igniter port, two steel swaged tubes	TM-F030-SX	618.00
30' : 175/200,000	One flanged/swaged alumatherm tube with sight glass and igniter port, one aluminized swaged tube, one steel swaged tube, one 10 ft turbulator	TM-1030-SX	714.00
Secondary Kits [add to above Primary Kits to make (40'), 50', 60' & 70' heaters]			
20'	Two steel swaged tubes (makes 50' heater with 30' primary)	TM-0020-SX	394.00
30'	Three steel swaged tubes (makes 60' heater with 30' primary)	TM-0030-SX	541.00
40'	Four steel swaged tubes (makes 70' heater with 30' primary)	TM-0040-SX	690.00
10'	One steel swaged tube, and one 10 ft turbulator	TM-1010-SX	266.00

NOTE: Secondary tube kit TM-1010-SX can be used with TM-F030-SX to create a 40 ft kit.

Do not use this kit to extend heater length beyond the maximum length approved for any input.

KIT ASSEMBLY CHART: previous page
S100 BURNER KITS: next page
S100 COMPLETE SYSTEMS: page T-24
OPTIONAL ACCESSORIES: page T-38 - 40



builderSchwank Tube Heaters S100U Series

(Side-by-Side 'U' Tube - NOT emissive coated)



S100 FEATURES SUMMARY:

- Line voltage thermostat ready
- Simple relay option for 24V thermostat
- Double-wide reflector covers both tubes
- Swing-down cabinet service access
- Whisper quiet ceramic burner

COMPLETE SYSTEMS:

MODEL	CAPACITY	Fuel	AVAILABLE TUBE		LIST PRICE
			LENGTH		
S100U 60	60,000 Btuh	NG	2 x 10'	\$	1,376.00
S100U 80	80,000 Btuh	NG	2 x 10'		1,376.00
			2 x 15'		1,611.00
S100U 110	110,000 Btuh	NG	2 x 15'		1,611.00
			2 x 20'		1,664.00
S100U 130	130,000 Btuh	NG	2 x 15'		1,611.00
			2 x 20'		1,664.00
S100U 155	155,000 Btuh	NG	2 x 20'		1,733.00
			2 x 30'		2,106.00
S100U 175	175,000 Btuh	NG	2 x 30'		2,266.00
S100U 200	200,000 Btuh	NG	2 x 30'		2,266.00

**Individual burner kits + tube kits
are shipped to assemble tube
heater orders.
~ See next page for details ~**

NOTE:

Standard burners are stocked for natural gas fuel only. Field conversion kits are required for conversion to LP gas - refer to **Burner Kits** on the page listed below

PRICES INCLUDE BURNER ASSEMBLY AND THE FOLLOWING COMPONENTS AS REQUIRED:

TUBE KIT: PRIMARY & SECONDARY TUBE(S), TURN BOX, DOUBLE REFLECTORS, TWO REFLECTOR END CAPS, REFLECTOR/TUBE HANGERS, TUBE COUPLER(S), AND TURBULATOR(S).

BURNER KIT: S/S FLEXIBLE GAS CONNECTOR, BIRDSCREEN ON BLOWER, IGNITER (FIELD MOUNTS IN 1st TUBE).

OPTIONAL: FRESH AIR INTAKE ADAPTER & WALL HOOD or ROOF CAP

All optional accessories are shipped in a separate carton.

All S100 series burner assemblies operate on line voltage (120VAC).

For 24V control of S100 Series heaters, see Optional Accessories and refer to '24V Guidelines' page T-61

*Please order heaters as burner kits +tube kit(s)
Heaters are shipped and invoiced as burner kits and tube kits*

S100U BURNER KITS: previous page

S100U BURNER & TUBE KIT CHART: page T-29

S100U TUBE KITS: page T-31

OPTIONAL ACCESSORIES: page T-38 - 40

builderSchwank Tube Heaters S100U Series

BURNER & 'U'-TUBE KIT* ASSEMBLY CHART

Which tube kits assemble with a burner kit?

Use the chart below to determine:

- ✓ Available tube length for each firing rate
- ✓ Available tube kit & quantities for each burner kit

- 1) Select HEATER MODEL
- 2) Order BURNER KIT
- 3) Order Quantity(s) of TUBE KIT(s)

Chain: $((\text{tube length}/10) \times 4 + 1) \times \text{length}$
'S' hooks: $(\text{tube length}/10) \times 8 + 2$

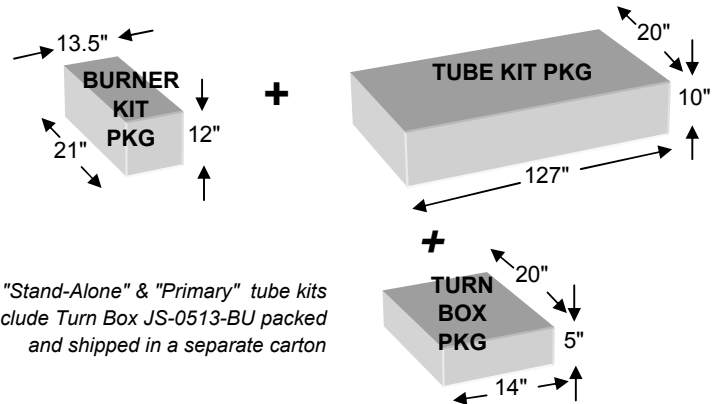

A flexible gas connector is now required to be supplied by the manufacturer with a tube heater. It is now included with the Burner Kit.

Tube Kit Gross Weight (lbs) ->

Side-by-Side Tubes Length ->

BURNER KIT (Includes S/S Flexible Gas Connector)
Gross Wt = 30 lbs

HEATER MODEL	BURNER KIT (Includes S/S Flexible Gas Connector) Gross Wt = 30 lbs		Stand-Alone **			Primary **		2ndary
			100	145	170	170	170	65
			10'	15'	20'	20'	20'	10'
			TM-1410-SU	TM-1415-SU	TM-1020-SU	TM-0020-SU	TM-A120-SU	TM-0010-SU
S100U 60	JS-E060-BN	2 x 10'	1					
S100U 80	JS-E080-BN	2 x 10'	1					
		2 x 15'		1				
S100U 110	JS-E110-BN	2 x 15'		1				
		2 x 20'			1			
S100U 130	JS-E130-BN	2 x 15'		1				
		2 x 20'			1			
S100U 155	JS-E155-BN	2 x 20'			1			
		2 x 30'				1+		1
S100U 175	JS-E175-BN	2 x 30'					1+	1
S100U 200	JS-E200-BN	2 x 30'					1+	1

*NOTE: S100U series tubes are NOT emissive coated

** These kits include Turn Box JS-0513-BU packed and shipped in a separate carton

Stand-Alone tube kits require no additional tube kits.

Primary tube kits require at least one additional Secondary tube kit.

Secondary tube kit require a Primary tube kit.

S100U Complete Systems: previous page
S100U Burner Kits: page T-30
S100U Tube Kits: next page



builderSchwank Tube Heaters S100U Series

BURNER KITS

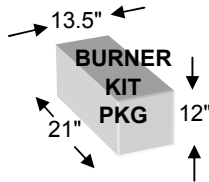

A flexible gas connector is now required to be supplied by the manufacturer with a tube heater. It is now included with the Burner Kit.

BURNER KITS ARE STOCKED IN NATURAL GAS - FIELD CONVERSION KITS FOR LP ARE LISTED BELOW**

INPUT	AVAILABLE	FUEL	INCLUDES		PART #	LIST PRICE*
	TUBE LENGTHS		FLEX GAS CONNECTOR			
45,000 Btuh	10', 20'	N.G.	1/2" X 24"		JS-E045-BN	\$ 737.00
60,000 Btuh	20', 30', 10'U	N.G.	1/2" X 24"		JS-E060-BN	737.00
80,000 Btuh	20', 30', 40', 10'U	N.G.	1/2" X 24"		JS-E080-BN	737.00
110,000 Btuh	30', 40', 50', 15'U, 20'U	N.G.	1/2" X 24"		JS-E110-BN	737.00
130,000 Btuh	30', 40', 50', 15'U, 20'U	N.G.	1/2" X 24"		JS-E130-BN	737.00
155,000 Btuh	40', 50', 60', 20'U, 30'U	N.G.	3/4" X 36"		JS-E155-BN	806.00
175,000 Btuh NG	50', 60', 70', 30'U	N.G.	3/4" X 36"		JS-E175-BN	838.00
NOTE**: 175,000 Btuh LP	50', 60', 70', 30'U	L.P.	3/4" X 36"		JS-E175-BL	838.00
200,000 Btuh	50', 60', 70', 30'U	N.G.	3/4" X 36"		JS-E200-BN	838.00

Packed inside the burner assembly carton: S/S FLEXIBLE GAS CONNECTOR, Burner fastening nuts, igniter, installation manual.
Burner & tube kit prices represent the component prices in conjunction with purchasing a complete system.

** Order 175,000 Btuh Propane burner direct from factory; Product Bulletins provide detail on 175,000 burner conversion

All S100 series burner assemblies operate on line voltage (120VAC).

For 24V control of S100 Series heaters, see Optional Accessories and refer to '24V Guidelines' page T-61

Please order heaters as burner kits +tube kit(s)

Heaters are shipped and invoiced as burner kits and tube kits

LPG FIELD CONVERSION KITS FOR S100 BURNERS

Conversion Kits for LP to NG are listed on Pages 72 & 73

INPUT		PART #	LIST PRICE*
45,000 Btuh	Field Conversion Kit NG to LP	JS-0556-XE	\$ 36.10
60,000 Btuh	Field Conversion Kit NG to LP	JS-0557-XX	24.80
80,000 Btuh	Field Conversion Kit NG to LP	JS-0559-XX	24.80
100,000 Btuh	Available in NG ONLY		
110,000 Btuh	Field Conversion Kit NG to LP	JS-0561-XX	24.80
130,000 Btuh	Field Conversion Kit NG to LP	JS-0563-XX	24.80
155,000 Btuh	Field Conversion Kit NG to LP	JS-0565-XX	24.80
175,000 Btuh	Field Conversion Kit NG to LP**	JS-0567-AA	24.80
200,000 Btuh	Field Conversion Kit NG to LP	JS-0567-CC	24.80

**See NOTE above

S100U SYSTEMS: page T-29
S100U KIT ASSEMBLY CHART: page T-30
S100 SYSTEMS: page T-24
S100 KIT ASSEMBLY CHART: page T-25
OPTIONAL ACCESSORIES: page T-38 - 40

SP-LTUB-IX-01A
RD: APR 2011
RL:USA - 11-1A
BA

builderSchwank Tube Heaters S100U Series

TUBE KITS (NOT emissive coated)

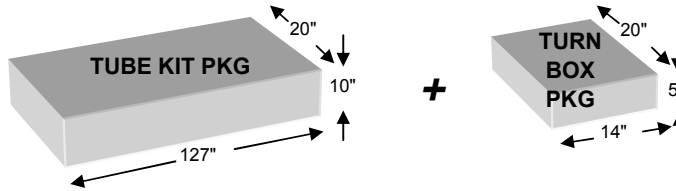

"Stand-Alone" & "Primary" tube kits include Turn Box JS-0513-BU packed and shipped in a separate carton

Stand-Alone tube kits require no additional tube kits.
Primary tube kits require at least one additional Secondary tube kit.
Secondary tube kit require a Primary tube kit.

Chain: $((\text{tube length}/10) \times 4 + 1) \times \text{length}$
at each suspension point
'S' hooks: $(\text{tube length}/10) \times 8 + 2$

Kit includes Tubes, Reflectors, End Caps, Hangers, Tube Couplers

<u>Stand-Alone</u>	<u>Description</u>	<u>TUBE KIT #</u>	<u>LIST PRICE*</u>
10'U : 60/80,000 Qty 2 x 10 ft tubes	One flanged/swaged aluminized tube with sight glass and igniter port, one steel swaged tube, one 4 ft turbulator and one 10 ft turbulator	TM-1410-SU	\$ 639.00
15'U : 80/110/130,000 Qty 2 x 10 ft tubes + Qty 2 x 5 ft tubes	One flanged/swaged aluminized tube with sight glass and igniter port, one 10' steel swaged tube, two 5' steel swaged tubes, one 4 ft turbulator and one 10 ft turbulator	TM-1415-SU	874.00
20'U : 110/130/155,000 Qty 4 x 10 ft tubes	One flanged/swaged aluminized tube with sight glass and igniter port, three steel swaged tubes, one 10 ft turbulator	TM-1020-SU	927.00
Primary Kits to make 30'U-Tube heaters - requires Primary + Secondary kit below			
20'U : 155,000 Qty 4 x 10 ft tubes	One flanged/swaged aluminized tube with sight glass and igniter port, three steel swaged tubes	TM-0020-SU	906.00
20'U : 175/200,000 Qty 4 x 10 ft tubes	One flanged/swaged alumatherm tube with sight glass and igniter port, one aluminized swaged tube, two steel swaged tube, one 10 ft turbulator	TM-A120-SU	1,034.00
Included with each of the above 'U'-tube kits is one turn box; packed and shipped in a separate carton (price is included in tube kit price)		JS-0513-BU	
Secondary Kits - add to above Primary Kit to make 30' U-Tube heaters			
2 x 10'	Two steel swaged tubes	TM-0010-SU	394.00

*Please order heaters as burner kits + tube kit(s)
 Heaters are shipped and invoiced as burner kits and tube kits*

S100U COMPLETE SYSTEMS: page T-28
S100 & S100U BURNER KITS: page T-30
S100 OPTIONAL ACCESSORIES: page T-38 - 40



WhisperJet TUBE HEATERS SET SERIES - TWO STAGE



SET FEATURES SUMMARY:

- 2 Stage burner operation
- Status indicator lights
- Straight tube or 'U'-tube configuration
- Swing-down cabinet service access
- Whisper quiet ceramic burner

COMPLETE SYSTEMS:

MODEL	CAPACITY High/Low Btuh	AVAILABLE TUBE		LIST PRICE
		Fuel	LENGTH	
SET 80/60	80,000/60,000	NG	20'	\$ 1,512.00
			30'	1,650.00
SET 110/75	110,000/75,000	NG	30'	1,650.00
			40'	1,789.00 *
SET 130/90	130,000/90,000	NG	30'	1,650.00
			40'	1,789.00 *
SET 155/110	155,000/110,000	NG	40'	1,860.00 *
			50'	2,104.00
SET 175/125	175,000/125,000	NG	50'	2,233.00 *
			60'	2,380.00
SET 200/140	200,000/140,000	NG	50'	2,233.00 *
			60'	2,380.00

**Individual burner kits + tube kits
are shipped to assemble tube
heater orders.
~ See next page for details ~**

* 40 ft heater price based on
TM-1040-SX Tube Kit

NOTE:

Standard burners are stocked for
natural gas fuel only.
Field conversion kits are required
for conversion to LP gas -
refer to **Burner Kits**
on the page listed below

PRICES INCLUDE THE FOLLOWING COMPONENTS AS REQUIRED:

BURNER KIT: S/S FLEXIBLE GAS CONNECTOR, STATUS INDICATOR LIGHTS, ELECTRICAL CORD & PLUG, FACTORY INSTALLED 24V/120V RELAY FOR 24V TWO-STAGE THERMOSTAT (THERMOSTAT EXTRA), BIRDSCREENED AIR INTAKE TO BLOWER.

OPTIONAL: FRESH AIR INTAKE ADAPTER & WALL HOOD or ROOF CAP

TUBE KIT: PRIMARY & SECONDARY TUBE(S), REFLECTORS, TWO REFLECTOR END CAPS, WIRE REFLECTOR/TUBE HANGERS, TUBE COUPLER(S), AND TURBULATOR(S). HOT ROLLED STEEL TUBES ARE NOT EMISSIVE COATED

Burner with accessories, and the reflectors, tubes and accessories are packaged separately and clearly labelled for ease of filling orders and shipping

All optional accessories are shipped in a separate carton.

SET TUBE KITS: next page
SET BURNER KITS: page T-34
SET KIT ASSEMBLY CHART: next page
OPTIONAL ACCESSORIES: page T-38 - 40

WhisperJet TUBE HEATERS SET SERIES - TWO STAGE



SET BURNER & TUBE KIT ASSEMBLY CHART

HEATER MODEL	BURNER KIT (Includes S/S Flexible Gas Connector) Gross Wt = 30 lbs	Nominal Length (ft)	'SET' TUBE KIT PART # & QUANTITY REQUIRED							
			Stand-Alone Kits			Primary Kits		Secondary Kits		
			120	170	210	165	165	120	165	
			20'	30'	40'	30'	30'	20'	30'	
			Tube Kit Shipping Weight (lbs)	TM-1420-SX	TM-1430-SX	TM-1040-SX	TM-F030-SX	TM-1030-SX	TM-0020-SX	TM-0030-SX
SET 80/60	JS-080T-BN	20'		1						
		30'			1					
SET 110/75	JS-110T-BN	30'			1					
		40'				1				
SET 130/90	JS-130T-BN	30'			1					
		40'				1				
SET 155/110	JS-155T-BN	40'					1+		1	1
		50'								
SET 175/125	JS-175T-BN	50'						1+	1	
		60'						1+		1
SET 200/140	JS-200T-BN	50'						1+	1	
		60'						1+		1

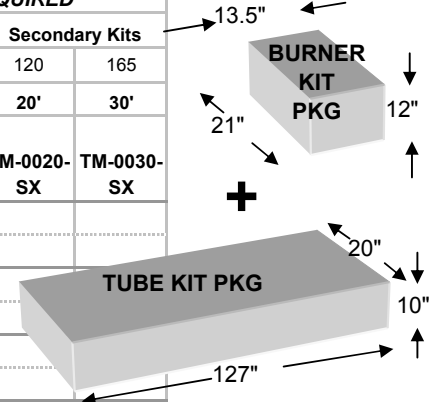

Please order heaters as burner kits + tube kit(s)
Heaters are shipped and invoiced as burner kits and tube kits

TUBE KITS (Not emissive coated)

Stand-Alone tube kits require no additional tube kits.

Primary tube kits require at least one additional Secondary tube kit.

Secondary tube kit require a Primary tube kit.

Kits include Tubes, Reflectors, Hangers, Tube Couplers

Chain: $((\text{tube length}/10) \times 2 + 1) \times \text{length}$
at each suspension point
'S' hooks: $(\text{tube length}/10) \times 4 + 2$

Stand-Alone	Description	TUBE KIT #	LIST PRICE*
20' : 80/60	One flanged/swaged aluminized tube with sight glass and igniter ports, one steel swaged tube, one 4 ft turbulator and one 10 ft turbulator	TM-1420-SX	\$ 491.00
30' : 80/60, 110/75, 130/90	One flanged/swaged aluminized tube with sight glass and igniter port, two steel swaged tubes, one 4 ft turbulator and one 10 ft turbulator	TM-1430-SX	629.00
40' : 110/75, 130/90, 155/110	One flanged/swaged aluminized tube with sight glass and igniter port, three steel swaged tubes, one 10 ft turbulator	TM-1040-SX	768.00
Primary Kits [to make (40'), 50', 60' & 70' heaters]			
30' : 155/110	One flanged/swaged aluminized tube with sight glass and igniter port, two steel swaged tubes	TM-F030-SX	618.00
30' : 175/125, 200/140	One flanged/swaged alumatherm tube with sight glass and igniter port, one aluminized swaged tube, one steel swaged tube, one 10 ft turbulator	TM-1030-SX	714.00
Secondary Kits [add to above Primary Kits to make 50' & 60' heaters]			
20'	Two steel swaged tubes, reflectors, hangers, couplers	TM-0020-SX	394.00
30'	Three steel swaged tubes, reflectors, hangers, couplers	TM-0030-SX	541.00

SET BURNER KITS: next page
SET COMPLETE SYSTEMS: previous page
SET KIT ASSEMBLY CHART: above
OPTIONAL ACCESSORIES: page T-38 - 40



WhisperJet TUBE HEATERS SET SERIES - TWO STAGE

'TWO STAGE' BURNER KITS

A flexible gas connector is now required to be supplied by the manufacturer with a tube heater. It is now included with the Burner Kit.

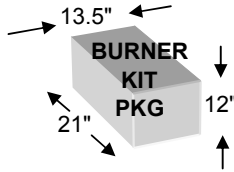

Based on the reliable STS-JZ burner with indicator lights, electrical cord, and **Two Stage** firing rate

BURNER INCLUDES: S/S FLEXIBLE GAS CONNECTOR, STATUS INDICATOR LIGHTS, ELECTRICAL CORD & PLUG, FACTORY INSTALLED 24V/120V RELAY FOR 24V TWO-STAGE THERMOSTAT, BIRDSCREENDAIR INTAKE ON BLOWER.

<u>CAPACITY</u>	<u>AVAILABLE TUBE LENGTHS</u>	<u>FUEL</u>	<u>INCLUDES FLEX GAS CONNECTOR</u>	<u>PART #</u>	<u>LIST PRICE*</u>
80,000 / 60,000 Btuh	20', 30'	N.G.	1/2" X 24"	JS-080T-BN	\$ 1,021.00
110,000 / 75,000 Btuh	30', 40'	N.G.	1/2" X 24"	JS-110T-BN	1,021.00
130,000 / 90,000 Btuh	30', 40'	N.G.	1/2" X 24"	JS-130T-BN	1,021.00
155,000 / 110,000 Btuh	40', 50'	N.G.	3/4" X 36"	JS-155T-BN	1,092.00
175,000 / 125,000 Btuh	50', 60'	N.G.	3/4" X 36"	JS-175T-BN	1,125.00
200,000 /140,000 Btuh	50', 60'	N.G.	3/4" X 36"	JS-200T-BN	1,125.00

The following items are packed inside the burner assembly carton: S/S Flexible Gas Connector, Installation manual; igniter and the burner fastening nuts & bolts are packed inside the burner housing.

All optional accessories are shipped in separate carton.

Burner kit part number includes the fuel suffix **N** (natural gas)

All burner assemblies require line voltage (120VAC) supply - Two stage thermostat is 24V.

LPG FIELD CONVERSION KITS FOR SET BURNERS

	<u>INPUT</u>		<u>PART #</u>	<u>LIST PRICE*</u>
<div style="border: 1px solid black; padding: 5px; width: fit-content;"> Conversion Kits for LP to NG are listed on pages 72 & 73 </div>	80,000/60,000 Btuh	Field Conversion Kit NG to LP	JS-0555-TC	\$ 42.30
	110,000/75,000 Btuh	Field Conversion Kit NG to LP	JS-0555-TG	42.30
	130,000/90,000 Btuh	Field Conversion Kit NG to LP	JS-0555-TK	42.30
	155,000/110,000 Btuh	Field Conversion Kit NG to LP	JS-0555-TO	42.30
	175,000 & 200,000 Btuh	Not convertible to LP		

THERMOSTAT CONTROL FOR 'SET' TWO STAGE:

	<u>PART #</u>	<u>LIST PRICE*</u>
Two Stage 24V Digital Thermostat	JS-0569-DT	\$ 213.00

Heaters are shipped and invoiced separately as burner kits and tube kits

Please order heaters as burner kits + tube kits

SET BURNER & TUBE KIT ASSEMBLY CHART: page T-33

SET TUBE KITS: previous page

OPTIONAL ACCESSORIES: page T-38 - 40



WhisperJet 'U'-TUBE HEATERS SETU SERIES - TWO STAGE

(Double Tube - Not emissive coated)



SETU FEATURES SUMMARY:

- 2 Stage burner operation
- Status indicator lights
- Double-wide reflector over 'U'-tube
- Swing-down cabinet service access
- Whisper quiet ceramic burner

COMPLETE SYSTEMS:

MODEL	CAPACITY		AVAILABLE TUBE		LIST PRICE
			LENGTH		
SETU 80/60	80,000/60,000	NG	2 x 10'	\$	1,660.00
			2 x 15'		1,895.00
SETU 110/75	110,000/75,000	NG	2 x 15'		1,895.00
			2 x 20'		1,948.00
SETU 130/90	130,000/90,000	NG	2 x 15'		1,895.00
			2 x 20'		1,948.00
SETU 155/110	155,000/110,000	NG	2 x 20'		2,019.00
			2 x 30'		2,392.00
SETU 175/125	175,000/125,000	NG	2 x 30'		2,553.00
SETU 200/140	200,000/140,000	NG	2 x 30'		2,553.00

**Individual burner kits + tube kits
are shipped to assemble tube
heater orders.
~ See next page for details ~**

NOTE:

Standard burners are stocked for natural gas fuel only. Field conversion kits are required for conversion to LP gas - refer to **Burner Kits** on the page listed below

PRICES INCLUDE THE FOLLOWING COMPONENTS AS REQUIRED:

BURNER KIT: S/S FLEXIBLE GAS CONNECTOR, STATUS INDICATOR LIGHTS, ELECTRICAL CORD & PLUG, FACTORY INSTALLED 24V/120V RELAY FOR 24V TWO-STAGE THERMOSTAT (THERMOSTAT EXTRA), BIRDSCREENED 4" DIAMETER AIR INTAKE ADAPTER ON BLOWER.

OPTIONAL: FRESH AIR INTAKE ADAPTER & WALL HOOD or ROOF CAP

TUBE KIT: PRIMARY & SECONDARY TUBE(S), REFLECTORS, TWO REFLECTOR END CAPS, WIRE REFLECTOR/TUBE HANGERS, TUBE COUPLER(S), AND TURBULATOR(S).

Burner with accessories, and the reflectors, tubes and accessories are packaged separately and clearly labelled for ease of filling orders and shipping

All optional accessories are shipped in a separate carton.

*Please order heaters as burner kits + tube kit(s)
Heaters are shipped and invoiced as burner kits and tube kits*

THERMOSTAT CONTROL FOR 'SETU' Two Stage:

	PART #		LIST PRICE*
Two Stage 24V Digital Thermostat	JS-0569-DT	\$	213.00

SETU BURNER KITS: page T-34
SETU TUBE KITS & ASSEMBLY CHART: next page
OPTIONAL ACCESSORIES: page T-38 - 40



WhisperJet TUBE HEATERS SETU SERIES - TWO STAGE

SETU BURNER & TUBE KIT ASSEMBLY

Chain: ((tube length/10) x 4 + 1) x length
at each suspension point
'S' hooks: (tube length/10) x 8 + 2

- 1) Select HEATER MODEL
- 2) Order BURNER KIT
- 3) Order Quantity(s) of TUBE KIT(s)

		SETU TUBE KIT PART # & QUANTITY REQUIRED					
		Stand-Alone **			Primary **		2ndary
		100	145	170	170	170	65
		10' x 2	15' x 2	20' x 2	20' x 2	20' x 2	10' x 2
		TM-1410-SU	TM-1415-SU	TM-1020-SU	TM-0020-SU	TM-A120-SU	TM-0010-SU
HEATER MODEL	BURNER KIT (Includes S/S Flexible Gas Connector) Gross Wt = 30 lbs	2 x 10'	1				
SETU 80/60	JS-080T-BN	2 x 15'		1			
SETU 110/75	JS-110T-BN	2 x 20'			1		
SETU 130/90	JS-130T-BN	2 x 15'		1			
		2 x 20'			1		
SETU 155/110	JS-155T-BN	2 x 20'			1		
		2 x 30'				1+	1
SETU 175/125	JS-175T-BN	2 x 30'				1+	1
SETU 200/140	JS-200T-BN	2 x 30'				1+	1

** These kits include Turn Box JS-0513-BU packed and shipped in a separate carton

SETU (Double) TUBE KITS (Not emissive coated)

Stand-Alone	Description (kits include reflectors, end caps, hangers, couplers)	TUBE KIT #	LIST PRICE*
10'U : 80/60 Qty 2 x 10 ft tubes	One flanged/swaged aluminized tube with sight glass and igniter port, one steel swaged tube, one 4 ft turbulator and one 10 ft turbulator	TM-1410-SU	\$ 639.00
15'U : 80/60, 110/75 Qty 2 x 10 ft tubes + Qty 2 x 5 ft tubes	One flanged/swaged aluminized tube with sight glass and igniter port, one 10' steel swaged tube, two 5' steel swaged tubes, one 4 ft turbulator and one 10 ft turbulator	TM-1415-SU	874.00
20'U : 110/75, 130/90, 155/110 Qty 4 x 10 ft tubes	One flanged/swaged aluminized tube with sight glass and igniter port, three steel swaged tubes, one 10 ft turbulator	TM-1020-SU	927.00
Primary Kits [to make 30'U-tube heaters - requires Primary + Secondary kit below]			
20'U : 155/110 Qty 4 x 10 ft tubes	One flanged/swaged aluminized tube with sight glass and igniter port, three steel swaged tubes	TM-0020-SU	906.00
20'U : 175/125, 200/140 Qty 4 x 10 ft tubes	One flanged/swaged alumatherm tube with sight glass and igniter port, one aluminized swaged tube, two steel swaged tube, one 10 ft turbulator	TM-A120-SU	1,034.00
	Included with each of the above tube kits is one turn box; packed and shipped in a separate carton (price is included in tube kit price)	JS-0513-BU	
Secondary Kit (add to above Primary Kit to make 30' U-Tube heaters)			
2 x 10'	Two steel swaged tubes, hangers, couplers, reflector	TM-0010-SU	394.00

SETU COMPLETE SYSTEMS: previous page
SETU BURNER KITS: next page
OPTIONAL ACCESSORIES: page T-38 - 40



WhisperJet TUBE HEATERS SETU SERIES - TWO STAGE

'TWO STAGE' BURNER KITS



A flexible gas connector is now required to be supplied by the manufacturer with a tube heater. It is now included with the Burner Kit.

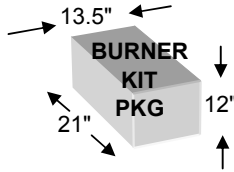

Based on the reliable STS-JZ burner with indicator lights, electrical cord, and **Two Stage** firing rate

BURNER INCLUDES: S/S FLEXIBLE GAS CONNECTOR, STATUS INDICATOR LIGHTS, ELECTRICAL CORD & PLUG, FACTORY INSTALLED 24V/120V RELAY FOR 24V TWO-STAGE THERMOSTAT, BIRDSCREENDAIR INTAKE ON BLOWER.

<u>CAPACITY</u>	<u>AVAILABLE TUBE LENGTHS</u>	<u>FUEL</u>	<u>INCLUDES FLEX GAS CONNECTOR</u>	<u>PART #</u>	<u>LIST PRICE*</u>
80,000 / 60,000 Btuh	20', 30'	N.G.	1/2" X 24"	JS-080T-BN	\$ 1,021.00
110,000 / 75,000 Btuh	30', 40'	N.G.	1/2" X 24"	JS-110T-BN	1,021.00
130,000 / 90,000 Btuh	30', 40'	N.G.	1/2" X 24"	JS-130T-BN	1,021.00
155,000 / 110,000 Btuh	40', 50'	N.G.	3/4" X 36"	JS-155T-BN	1,092.00
175,000 / 125,000 Btuh	50', 60'	N.G.	3/4" X 36"	JS-175T-BN	1,125.00
200,000 /140,000 Btuh	50', 60'	N.G.	3/4" X 36"	JS-200T-BN	1,125.00

The following items are packed inside the burner assembly carton: S/S Flexible Gas Connector, Installation manual; igniter and the burner fastening nuts & bolts are packed inside the burner housing.

All optional accessories are shipped in separate carton.

Burner kit part number includes the fuel suffix **N** (natural gas)

All burner assemblies require line voltage (120VAC) supply - Two stage thermostat is 24V.

LPG FIELD CONVERSION KITS FOR SET BURNERS

	<u>INPUT</u>		<u>PART #</u>	<u>LIST PRICE*</u>
Conversion Kits for LP to NG are listed on page T-52	80,000/60,000 Btuh	Field Conversion Kit NG to LP	JS-0559-XX	\$ 24.80
	110,000/75,000 Btuh	Field Conversion Kit NG to LP	JS-0561-XX	24.80
	130,000/90,000 Btuh	Field Conversion Kit NG to LP	JS-0563-XX	24.80
	155,000/110,000 Btuh	Field Conversion Kit NG to LP	JS-0565-XX	24.80
	175,000 & 200,000 Btuh	Not convertible to LP		

THERMOSTAT CONTROL FOR 'SET' TWO STAGE:

	<u>PART #</u>	<u>LIST PRICE*</u>
Two Stage 24V Digital Thermostat	JS-0569-DT	\$ 213.00

* Burner & tube kit prices represent the component prices in conjunction with purchasing a complete system.

Heaters are shipped and invoiced separately as burner kits and tube kits

Please order heaters as burner kits + tube kits

SETU BURNER & TUBE KIT ASSEMBLY CHART: previous page
SETU TUBE KITS: previous page
OPTIONAL ACCESSORIES: page T-38 - 40



OPTIONAL ACCESSORIES - Page 1 of 4

S100(U), SET(U) TUBE HEATERS

More Options: Next pages.
Thermostats: 4th Page



IMPORTANT: TUBE HEATER GAS CONNECTION - JUNE 2009

ANSI Z83.20-2008 / CSA 2.34-2008

New Standard for Gas-Fired Low-Intensity Infrared Tube Heaters

requires the mandatory supply of specific gas connector by the manufacturer:

USA : A S/S FLEXIBLE Gas Connector IS SUPPLIED with Tube Heater:

Note: Minimum length for tube heater flexible connector is 24 inches .

Refer to table below for correct sized connector that is supplied and must be installed.

Gas connector is shipped in the Burner Kit carton

Mandatory S/S Flex Gas Connector	
Input Btuh	Required ID x Length
45,000	1/2" x 24"
60,000	1/2" x 24"
80,000	1/2" x 24"
100,000	1/2" x 24"
110,000	1/2" x 24"
130,000	1/2" x 24"
155,000	3/4" x 36"
175,000	3/4" x 36"
200,000	3/4" x 36"

Flexible Gas Connectors:

S/S FLEXIBLE - Replacement Parts

S/S FLEXIBLE Connector 1/2" X 24" - for 45,000 up to 130,000 Btuh
JL-0771-XX \$33.00

S/S FLEXIBLE Connector 3/4" x 36" - for 155,000 up to 200,000 Btuh
JL-0771-YY 102.00

Hanging Chain:

#2 Lion Chain - 115 lb work load - 200 ft roll



PART # JL-0800-XX
LIST PRICE \$97.00

#8 Jack Chain - 60 lb work load - 50 ft box



JL-0798-JC 60.00

Quantity of Chain required: $\left\{ \begin{array}{l} \text{S100, SET Series heater} = ((\text{heater tube length}/10) \times 2) + 1 \times \text{length of chain at each suspension point} \\ \text{ie: S100 40 ft heater 3 ft below structural support} = ((40/10) \times 2) + 1 \times 3 = 27 \text{ ft of chain} \end{array} \right.$

Safety Snap Hooks - 2"



Package of 24 JL-0800-SH 40.20
Package of 100 JL-0800-SH-B 123.00

'S' Hooks - 1 7/8" - Package of 25

JL-0798-SH 23.20

Quantity of 'Snap' or 'S' Hooks: S100, SET Series quantity required = $((\text{tube length}/10) \times 4) + 2$: ie: SET x 40 ft = $(40/10) \times 4) + 2 = 18$ hooks

CLEARANCE TO COMBUSTIBLES SIGN

Metal sign - 18" x 6"
- 3/4" red lettering on white background



JL-0798-CS 37.10



OPTIONAL ACCESSORIES - Page 2 of 4

S100(U) & SET(U) Series TUBE HEATERS

Combustion Air Intake: *Optional*

Not all tube heater installations require outside air for combustion.

Schwank recommends outside combustion air when:

- A building is under negative air condition
- Dusty environment in the building
- Chemical or process contaminants such as welding smoke present
- Sealed combustion is required or advised for the project



Wall Hood



Roof Cap

Outside combustion air can be acquired from an outside wall or from the roof using 4" diameter vent pipe.

Please refer to the installation manual for complete details on venting and combustion air duct.

	<u>PART #</u>	<u>LIST PRICE</u>
Fresh Air Intake Adapter 4" (for S100[U] & SET[U] Series) <i>Mounts to exterior top of burner cabinet</i>	JS-0532-SE	\$ 40.20
Outside Air Intake Wall Vent Hood 4" ~ birdscreened, <i>flush mount</i>	JS-0532-VC	26.70
4" Roof Cap - fits single wall pipe	JA-0530-XX	48.00

Vent Stuff:



Wall Terminal*

Flue Vent Terminals:

- 4" horizontal (through wall)
- 6" horizontal

<u>PART #</u>	<u>LIST PRICE</u>
JA-0528-XX	\$ 39.50
JA-0529-XX	48.00

HORIZONTAL VENTING: Use this termination cap by Schwank, or use an approved "High Wind" vent terminal.

VERTICAL VENTING: Use the termination cap for double walled pipe as supplied by the vent pipe manufacturer

** Fits single wall vent pipe - field modification required to fit to double wall pipe*

Vent Tee 4" X 4" X 6"
(Two Couplers JA-0516-AA are optional)



4" x 4" x 6"
Vent Tee

4" x 8" Aluminized Steel Coupler with 2 x U-Bolts

JA-0514-XX	197.00
JA-0516-AA	41.70



OPTIONAL ACCESSORIES - Page 3 of 4

S100(U) & SET(U) Series TUBE HEATERS

S100 & SET Series Elbow Kits: *(These models do NOT have a reflector cover on elbow)*

S100 & SET 90° Aluminized Steel Elbow Kit***

Use two 90° Kits to create a 180°
 OR order Model S100U or SETU



***S100 Elbow Kit includes: one elbow, one
 4" swaged tube coupler and two S100 reflector
 end caps)

JS-0508-SM \$ 118.00

S100 & SET:

For 180° Aluminized Steel Elbow Kit - Order TWO x JS-0508-SM

Qty 2 x JS-0508-SM 236.00

Other Options:

Reflector Side Extension Extension (- All models - 10" deep x 116" long)

JS-0509-KT \$ 47.00

5 ft length Tube Protection Screen *(custom order: longer lead time)*

JA-0780-XS 60.00

THERMOSTATS & CONTROL OPTIONS on next page



OPTIONAL ACCESSORIES - Page 4 of 4

S100(U) & SET(U) Series TUBE HEATERS

THERMOSTAT CONTROL FOR 'SET' TWO STAGE:

Two Stage 24V Digital Thermostat

JS-0569-DT

\$

LIST PRICE

213.00

NOTE: A two stage thermostat can control only one single SET tube heater.

THERMOSTATS & CONTROLS S100 / S100U Series:

LINE VOLTAGE:

Line Voltage Thermostat °F & °C Dual Scale
S100 tube heaters are "factory ready" for line voltage thermostat



JL-0772-XX

\$ 39.50

24 VOLT:

Low Voltage (24V) Digital Thermostat °F & °C Scales
(S100 requires one of 24V options below)



JS-0569-WR

\$ 66.00

TruTemp ENERGY MANAGEMENT:

TruTemp Thermostat
(S100 requires one of 24V options below) (see more info on the TruTemp on page T-50)



JM-0150-XX

213.00

MOISTURE PROOF:

Moisture Proof Thermostat (NEMA 4X enclosure)



JS-0570-XX

341.00

24 VOLT CONTROL OPTIONS: (Required for TruTemp or 24V thermostat) Refer to guidelines page T-61

Control a Single S100 Heater with a 24V Thermostat:



S100 24V Thermostat Control Relay Kit JS-0568-KT

\$ 37.40

JS-0568-KT

FIELD MOUNT IN BURNER:
2 SCREWS MOUNTS TO CONTROL PLATE

Control

24V Transformer/Relay Kit

JM-0303-KT

FIELD MOUNTS ON EXTERIOR BURNER HOUSING OF ONE HEATER IN ZONE



JM-0303-KT

107.00

60 Minute Timer

74-US

100.00

SR-LTUB-IX-01A
RD: APR 2011

RL:USA - 11-1A
BA

Residential Tube Heater

STR-JZ Series

RESIDENTIAL GARAGE/SHOP HEATER



STR-JZ SERIES HEATER
includes a 24 volt thermostat

PRICES INCLUDE BURNER ASSEMBLY AND THE FOLLOWING COMPONENTS:

BURNER KIT: S/S FLEXIBLE GAS CONNECTOR, AIR INTAKE HOOD, 120V 3-PRONGED PLUG, AND 24V THERMOSTAT WITH 20 FT OF 18/2 WIRE;

TUBE KIT: PRIMARY TUBE, EMISSIVE COATED SECONDARY TUBE(S), TWO END PLATE HANGERS, WEBBED REFLECTOR/TUBE HANGERS, FOCUS SHIELD REFLECTORS, TUBE COUPLER(S), TURBULATOR(S),

COMPLETE SYSTEMS:

MODEL	CAPACITY		AVAILABLE TUBE		LIST PRICE
			LENGTH		
STR-JZ 45	45,000 Btuh	NG	10'	\$	1,350.00
			20'		1,474.00
STR-JZ 60	60,000 Btuh	NG	20'		1,474.00
			30'		1,670.00

**Individual burner kits + tube kits
are shipped to assemble tube
heater orders.**
~ See next page for details ~

Burners are stocked in natural gas only - Field conversion kit required for LP - see next page

Heaters are shipped and invoiced as burner kits and tube kits. Please order kits.

STR-JZ BURNER & TUBE KIT ASSEMBLY CHART

MODEL	BURNER KIT (Includes S/S Flexible Gas Connector)	Nominal Length (ft)	STR-JZ TUBE KIT PART # & QUANTITY REQUIRED		
			Stand-Alone Kits <u>Only</u>		
		Tube Kit Gross Weight (lbs)	70	120	170
STR-JZ 45	JS-R045-AN	10'	1		
		20'		1	
STR-JZ 60	JS-R060-AN	20'		1	
		30'			1

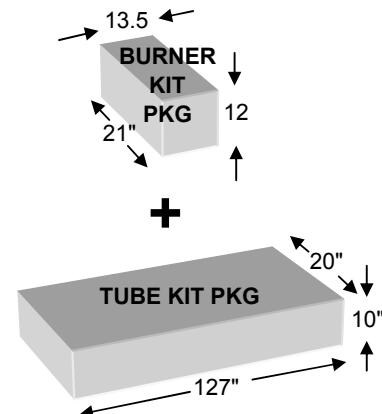

Heaters are shipped and invoiced as burner kits and tube kits. Please order kits.

STR-JZ BURNER & TUBE KITS: next page
STR-JZ ACCESSORIES: page T-37



Residential Tube Heater STR-JZ Series

A flexible gas connector is now required to be supplied by the manufacturer with a tube heater. It is now included with the Burner Kit.

BURNER KITS - STR-JZ

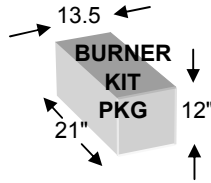

<u>CAPACITY</u>	<u>AVAILABLE TUBE LENGTHS</u>	<u>FUEL</u>	<u>INCLUDES FLEX GAS CONNECTOR</u>	<u>PART #</u>	<u>LIST PRICE</u>
45,000	10', 20'	N.G.	1/2" X 24"	JS-R045-AN	\$ 908.00
60,000	20', 30'	N.G.	1/2" X 24"	JS-R060-AN	908.00

The following items are packed inside the burner assembly carton: S/S FLEXIBLE GAS CONNECTOR, Burner fastening nuts & bolts, fresh air intake cap, 24V thermostat with 20 ft of 18/2 wire, installation manual.

LPG FIELD CONVERSION KITS FOR STR-JZ BURNERS

Conversion Kits for LP to NG are listed on page T-52

<u>INPUT</u>		<u>PART #</u>	<u>LIST PRICE*</u>
45,000 Btuh	Field Conversion Kit NG to LP	JS-0556-XC	\$ 46.40
60,000 Btuh	Field Conversion Kit NG to LP	JS-0557-XX	24.80

TUBE KITS - STR-JZ

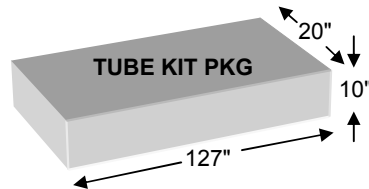

Chain: ((tube length/10) + 2) x length at each suspension point
'S' hooks: (tube length/10) x 2 + 4

Tube kits include '-JZ' 116" reflectors, webbed hangers, end plate hangers, couplers, and tubes as listed below:

<u>Stand-Alone</u>	<u>Description</u> (includes Reflectors, Hangers, and Couplers)	<u>PART #</u>	<u>LIST PRICE</u>
10' : 45,000 Btuh	One flanged/swaged aluminized tube with no ports, one 5 ft turbulator	TS-4510-JZ	\$ 442.00
20' : 45,000/60,000	One flanged/swaged aluminized tube with no ports, one emissive coated steel swaged tube, one 4 ft turbulator and one 10 ft turbulator	TS-1420-JZ	566.00
30' : 60,000	One flanged/swaged aluminized tube with no ports, two emissive coated steel swaged tubes, one 4 ft turbulator and one 10 ft turbulator	TS-1430-JZ	762.00

OPTIONAL ACCESSORIES

STR-JZ Series

#8 Hanging Chain - (box of 50' Jack Chain - 'S' hooks separate - see next item)	JL-0798-JC	\$	60.00
'S' Hooks - 1 7/8" - Package of 25	JL-0798-SH		23.20
INSTALLER CONVENIENCE KIT* (* Kit includes: 4" x 10' aluminum flexible duct, 4" wall flue terminal and 10' jack chain)	JS-0598-XX		101.00
4" Horizontal Wall Flue Terminal	JA-0528-XX		39.50
4" Roof Vent Cap	JA-0530-XX		48.00



IMPORTANT: TUBE HEATER GAS CONNECTION - JUNE 2009

ANSI Z83.20-2008 / CSA 2.34-2008

**New Standard for Gas-Fired Low-Intensity Infrared Tube Heaters
requires the mandatory supply of specific gas connector by the manufacturer:**

USA : A S/S FLEXIBLE Gas Connector IS SUPPLIED with Tube Heater:

Note: Minimum length for tube heater flexible connector is 24 inches .

Refer to table below for correct sized connector that is supplied and must be installed.

Gas connector is shipped in the Burner Kit carton

Mandatory S/S Flex Gas Connector	
Input Btuh	Required ID x Length
45,000	1/2" x 24"
60,000	1/2" x 24"

Flexible Gas Connectors: S/S FLEXIBLE - Replacement Parts

S/S FLEXIBLE Connector 1/2" X 24" - for 45,000 up to 130,000 Btuh
JL-0771-XX \$33.00

Decorative 'Tuxedo' Grille Kit - Matte Black finish

Decorative 'Tuxedo' Grille Kit - Matte Black Grille - 10 foot section	TG-0010-KT	\$	360.00
---	------------	----	--------

Matte black grille & aluminized steel framing dress up a tube heater installation - secures with tabs to 'JZ' Series heater

STR-JZ Elbow Kits:

ST-JZ 90° Aluminized Steel Elbow & Reflector Cover Kit**: <i>(Elbow can be installed right or left hand - includes coupler, reflector cover, end plate/hanger)</i>	JS-0508-JZ	\$	160.00
ST-JZ 180° Elbow & Reflector Kit: ORDER: TWO x JS-0508-JZ 90° ELBOW KITS	Qty 2 x JS-0508-JZ		320.00
Reflector Side Extension 10" deep x 116" long	JS-0509-KT	\$	47.00

STR-JZ COMPLETE SYSTEMS: page T-35
STR-JZ BURNER & TUBE KITS: previous page



CARWASH, HARSH ENVIRONMENT & OUTDOOR TUBE HEATERS



SPW-JZ Powder Coated Steel Burner Cabinet

- Patio heating
- Wash bay applications



STW-JZ Stainless Steel Burner Cabinet

- Harsh environment/power wash bays
- Food industry applications

Three Models to suit the application and environment:

SPW-JZ: Powder Coated Burner Cabinet

- ✓ Preferred model for covered and enclosed patio areas; most economical solution
- ✓ Fresh air adapter and cap for 'outside' combustion air
- ✓ Weather tight powder coated burner cabinet
- ✓ Moisture resistant spark ignition package
- ✓ Designer color blends with patio aesthetics
- ✓ Tough, durable finish
- ✓ Best choice for patios, outdoor, wash bays and damp environments
- ✓ Aluminized steel: reflectors and tubes

STW-JZ: Stainless Steel Burner Cabinet

- ✓ Preferred model for harsh environments
- ✓ Recommended for use in harsh environment applications: Car & truck power washes
- ✓ Weather tight stainless steel burner cabinet
- ✓ Fresh air adapter and cap for 'outside' combustion air
- ✓ Aluminized steel: reflectors and tubes
- ✓ Moisture resistant spark ignition package

STW-JZ2: ALL Stainless Model

- ✓ Use ONLY where 'Stainless' is a necessity -> in highly corrosive or food service applications
- ✓ Least infrared heat output of the harsh environment models
 - Stainless steel tubing has a low emissivity value -> does not exchange heat efficiently
 - Use the 'next size up heater' for infrared output equivalency to STW-JZ
- ✓ Least recommended model due to lower infrared output
- ✓ Stainless steel reflectors and stainless steel tubes
- ✓ Weather tight stainless steel burner cabinet
- ✓ Moisture resistant spark ignition package
- ✓ Fresh air adapter and cap for 'outside' combustion air



OUTDOOR TUBE HEATER

SPW-JZ Series

PATIO*, OUTDOOR, WASH BAYS & DAMP ENVIRONMENT



Powder Coated Steel Burner Cabinet - Aluminized Steel Reflectors & Tubes
SPW-JZ is supplied complete with Fresh Air Intake Adapter and Intake Wall Hood (birdsgreened).

* RECOMMENDED PATIO HEATER SIZES ARE HIGHLIGHTED IN BOLD FACE

PRICES INCLUDE BURNER ASSEMBLY WITH PAINTED STEEL HOUSING AND THE FOLLOWING COMPONENTS:

S/S FLEXIBLE GAS CONNECTOR, MOISTURE & ACID RESISTANT DIRECT SPARK IGNITION SYSTEM, OUTSIDE AIR ADAPTER AND WALL CAP, ALUMINIZED STEEL TUBES AND REFLECTORS, TWO END PLATE HANGERS, 'JZ' WEBBED HANGERS, TUBE COUPLERS, AND REQUIRED TURBULATOR(S).

COMPLETE SYSTEMS:

MODEL	Btuh INPUT	LENGTHS	LIST PRICE	Outdoor Patio	Hand Wash Area	Damp Areas
SPW-JZ 45*	45,000	10'	\$ 1,648.00	✓	✓	✓
		20'	1,813.00	✓	✓	✓
SPW-JZ 60*	60,000	20'	1,813.00	✓	✓	✓
		30'	2,006.00	✓	✓	✓
SPW-JZ 80*	80,000	20'	1,813.00	✓	✓	✓
		30'	2,006.00	✓	✓	✓
		40'	2,229.00	✓	✓	✓
SPW-JZ 110*	110,000	30'	2,006.00	✓	✓	✓
		40'	2,229.00	✓	✓	✓
		50'	2,517.00	✓	✓	✓
SPW-JZ 130*	130,000	30'	2,006.00	✓	✓	✓
		40'	2,229.00	✓	✓	✓
		50'	2,517.00	✓	✓	✓
SPW-JZ 155	155,000	40'	2,298.00	✓	✓	✓
		50'	2,586.00	✓	✓	✓
SPW-JZ 175	175,000	60'	2,789.00	✓	✓	✓
		50'	2,714.00	✓	✓	✓
SPW-JZ 200	200,000	60'	2,917.00	✓	✓	✓
		70'	3,130.00	✓	✓	✓
SPW-JZ 200	200,000	50'	1,407.00	✓	✓	✓
		60'	2,917.00	✓	✓	✓
SPW-JZ 200	200,000	60'	2,917.00	✓	✓	✓
		70'	3,130.00	✓	✓	✓

Individual burner kits + tube kits are shipped to assemble tube heater orders.
~ See next page for details ~

40 ft heater price based on TW-1040-JZ Tube Kit

NOTE:
Standard burners are stocked for natural gas fuel only. Field conversion kits are required for conversion to LP gas - refer to **Burner Kits** on the page listed below

NOTE: SPW-JZ Series burners require 120V supply

* RECOMMENDED PATIO HEATER SIZES ARE HIGHLIGHTED IN BOLD FACE

KIT ASSEMBLY CHART: next page
SPW BURNER KITS: page T-41
TUBE KITS: page T-45
OPTIONAL ACCESSORIES: page T-48



OUTDOOR TUBE HEATER

SPW-JZ Series

BURNER & TUBE KIT ASSEMBLY CHART

A flexible gas connector is now required to be supplied by the manufacturer with a tube heater. It is now included with the Burner Kit.

MODEL: SPW-JZ: Patio, Hand Car Wash Areas & Damp Environment Applications
Aluminized Steel Tubes and Reflectors

Burner Kits: next page
Tube Kits: page T-52

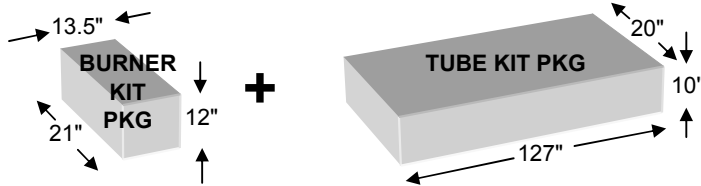

Chain: ((tube length/10) + 2) x length at each suspension point
'S' hooks: (tube length/10) x 2 + 4

			Order: SPW-JZ TUBE KIT PART # & QUANTITY REQUIRED								
			Stand-Alone Kits				Primary Kits +		Secondary Kits		
			70	120	170	210	165	165	120	165	210
			10'	20'	30'	40'	30'	30'	20'	30'	40'
			Tube Kit Gross Weight (lbs) →								
			Nominal Length (ft) →								
			BURNER KIT (Includes S/S Flex Gas Connector) Gross Wt = 30 lb								
MODEL			TS-4510-JZ	TW-1420-JZ	TW-1430-JZ	TW-1040-JZ	TW-F030-JZ	TW-1030-JZ	TW-0020-JZ	TW-0030-JZ	TW-0040-JZ
SPW-JZ 45	JS-045W-BN	10'	1								
		20'		1							
SPW-JZ 60	JS-060W-BN	20'		1							
		30'			1						
SPW-JZ 80	JS-080W-BN	20'		1							
		30'			1						
		40'				1					
SPW-JZ 110	JS-110W-BN	30'			1						
		40'				1					
		50'					1+		1		
SPW-JZ 130	JS-130W-BN	30'			1						
		40'				1					
		50'					1+		1		
SPW-JZ 155	JS-155W-BN	40'				1					
		50'					1+		1		
		60'							1+	1	
SPW-JZ 175	JS-175W-BN	50'						1+	1		
		60'						1+		1	
		70'							1+		1
SPW-JZ 200	JS-200W-BN	50'						1+	1		
		60'						1+		1	
		70'							1+		1

Stand-Alone tube kits require no additional tube kits.
 Primary tube kits require at least one additional Secondary tube kit.
 Secondary tube kit require a Primary tube kit.

COMPLETE SYSTEMS: previous page
SPW BURNER KITS: next page
TUBE KITS: page T-45
OPTIONAL ACCESSORIES: page T-48



OUTDOOR TUBE HEATER SPW-JZ Series

POWDER COATED STEEL BURNER HOUSING

Car Wash / Outdoor Patio* / Damp Environment

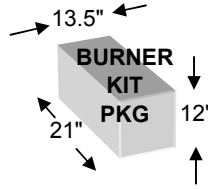

for Power Wash Bays and Harsh Environment see:

STW-JZ: Stainless Steel Burner Housing, Aluminized Steel Tubes & Reflectors -> next page

STW-JZ2: Stainless Steel Burner Housing, Stainless Steel Tubes & Reflectors -> next page

* **BOLD FACE** means size is suitable for patios

Btuh	INPUT	AVAILABLE TUBE LENGTHS	Outdoor Patio	Hand Wash Areas	Damp Areas	FUEL	INCLUDES FLEX GAS CONNECTOR	ORDER PART #		LIST PRICE
45,000		10', 20'	✓	✓	✓	N.G.	1/2" X 24"	JS-045W-BN	\$	1,206.00
60,000		20', 30'	✓	✓	✓	N.G.	1/2" X 24"	JS-060W-BN		1,206.00
80,000		20', 30', 40'	✓	✓	✓	N.G.	1/2" X 24"	JS-080W-BN		1,206.00
110,000		30', 40', 50'	✓	✓	✓	N.G.	1/2" X 24"	JS-110W-BN		1,206.00
130,000		30', 40', 50'	✓	✓	✓	N.G.	1/2" X 24"	JS-130W-BN		1,206.00
155,000		40', 50', 60'		✓	✓	N.G.	3/4" X 36"	JS-155W-BN		1,275.00
175,000	NG	50', 60', 70'		✓	✓	N.G.	3/4" X 36"	JS-175W-BN		1,307.00
175,000	LP**	50', 60', 70'		✓	✓	N.G.	3/4" X 36"	JS-175W-BL		1,307.00
200,000		50', 60', 70'		✓	✓	N.G.	3/4" X 36"	JS-200W-BN		1,307.00

** NOTE: Order 175,000 Btuh Propane burner direct from factory; Product Bulletins provide detail on 175,000 burner conversion

The following items are packed inside the burner Kit carton: S/S FLEXIBLE GAS CONNECTOR, Burner fastening nuts & bolts, flange gasket, igniter (mounted), fresh air intake cap for wall, installation manual.

All burner assemblies operate on line voltage (120VAC).

Heaters are shipped and invoiced as burner kits and tube kits. Please order kits.

LPG FIELD CONVERSION KITS FOR SPW-JZ BURNERS

	INPUT		PART #	LIST PRICE*
Conversion Kits for LP to NG are listed on page T-52	45,000 Btuh	Field Conversion Kit NG to LP	JS-0556-XC	\$ 46.40
	60,000 Btuh	Field Conversion Kit NG to LP	JS-0557-XX	24.80
	80,000 Btuh	Field Conversion Kit NG to LP	JS-0559-XX	24.80
	110,000 Btuh	Field Conversion Kit NG to LP	JS-0561-XX	24.80
	130,000 Btuh	Field Conversion Kit NG to LP	JS-0563-XX	24.80
	155,000 Btuh	Field Conversion Kit NG to LP	JS-0565-XX	24.80
	175,000 Btuh	Field Conversion Kit NG to LP**	JS-0567-AA	24.80
	200,000 Btuh	Field Conversion Kit NG to LP	JS-0567-CC	24.80

**See NOTE above

COMPLETE SPW-JZ SYSTEMS: page T-39
SPW-JZ BURNER KITS: previous page
OPTIONAL ACCESSORIES: page T-48



HARSH ENVIRONMENT & OUTDOOR TUBE HEATER STW-JZ & STW-JZ2 Series

POWERWASH & HARSH ENVIRONMENT



Stainless Steel Burner Housing

STW-JZ = Aluminized Steel Reflectors & Tubes

STW-JZ2 = Stainless Steel Reflectors & Tubes

COMPLETE SYSTEMS:

COMPLETE SYSTEM LIST PRICES:

MODEL	INPUT	TUBE LENGTHS	COMPLETE SYSTEM LIST PRICES:	
			Aluminized Tubes & Reflectors -JZ	Stainless Tubes & Reflectors -JZ2
STW-JZ 45	45,000 Btuh	10'	\$ 2,128.00	\$ 2,816.00
		20'	2,293.00	3,637.00
STW-JZ 60	60,000 Btuh	20'	2,293.00	3,637.00
		30'	2,486.00	4,532.00
STW-JZ 80	80,000 Btuh	20'	2,293.00	3,637.00
		30'	2,486.00	4,532.00
		40' *	2,709.00	5,417.00
STW-JZ 110	110,000 Btuh	30'	2,486.00	4,532.00
		40' *	2,709.00	5,417.00
		50'	2,997.00	6,355.00
STW-JZ 130	130,000 Btuh	30'	2,486.00	4,532.00
		40' *	2,709.00	5,417.00
		50'	2,997.00	6,355.00
STW-JZ 155	155,000 Btuh	40' *	2,778.00	5,486.00
		50'	3,066.00	6,424.00
		60'	3,269.00	7,331.00
STW-JZ 175	175,000 Btuh	50'	3,194.00	6,456.00
		60'	3,397.00	7,363.00
		70'	3,610.00	8,332.00
STW-JZ 200	200,000 Btuh	50'	3,194.00	6,456.00
		60'	3,397.00	7,363.00
		70'	3,610.00	8,332.00
FOR BURNER & TUBE KITS SEE:			PAGES T-50 to T-52	PAGES T-53 to T-54

**Individual burner kits + tube kits are shipped to assemble tube heater orders.
~ See next page for details ~**

* 40 ft heater price based on TW-1040-JZ Tube Kit

NOTE:
Standard burners are stocked for natural gas fuel only. Field conversion kits are required for conversion to LP gas - refer to **Burner Kits** on the page listed below

PRICES INCLUDE BURNER ASSEMBLY WITH STAINLESS STEEL HOUSING AND SUFFICIENT QUANTITIES OF THE FOLLOWING COMPONENTS:

S/S FLEXIBLE GAS CONNECTOR, MOISTURE & ACID RESISTANT DIRECT SPARK IGNITION SYSTEM, AIR INTAKE ADAPTER & HOOD, TWO END PLATE HANGERS, WEBBED HANGERS, PRIMARY & SECONDARY TUBES, FOCUS SHIELD REFLECTORS, TUBE COUPLER(S), AND REQUIRED TURBULATOR(S).

KIT ASSEMBLY CHART: next page
STW BURNER KITS: page T-51
TUBE KITS: page T-52
OPTIONAL ACCESSORIES: page T-55



HARSH ENVIRONMENT & OUTDOOR TUBE HEATER STW-JZ Series

A flexible gas connector is now required to be supplied by the manufacturer with a tube heater. It is now included with the Burner Kit.

BURNER & TUBE KIT ASSEMBLY CHART

MODEL: STW-JZ: Power Car Wash Areas & Harsh Environment Applications

Stainless Steel Burner & Aluminized Steel Tubes and Reflectors

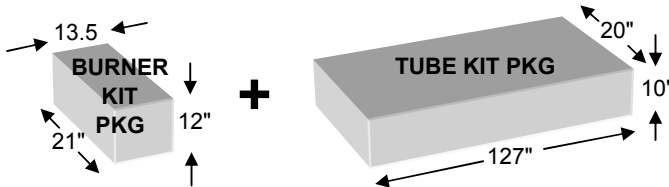

Chain: $((\text{tube length}/10) + 2) \times \text{length}$ at each suspension point
'S' hooks: $(\text{tube length}/10) \times 2 + 4$

Stand-Alone tube kits require no additional tube kits.
Primary tube kits require at least one additional Secondary tube kit.
Secondary tube kit require a Primary tube kit.

		STW-JZ TUBE KIT PART # & QUANTITY REQUIRED								
		Stand-Alone Kits				Primary Kits +		Secondary Kits		
		70	120	170	210	165	165	120	165	210
		10'	20'	30'	40'	30'	30'	20'	30'	40'
		Tube Kit Gross Weight (lbs) -> Nominal Length ->								
		BURNER KIT (Includes S/S Flex Gas Connector) Gross Wt = 30 lb								
MODEL		TS-4510-JZ	TW-1420-JZ	TW-1430-JZ	TW-1040-JZ	TW-F030-JZ	TW-1030-JZ	TW-0020-JZ	TW-0030-JZ	TW-0040-JZ
STW-JZ 45	JS-045P-BN	10'	1							
		20'		1						
STW-JZ 60	JS-060P-BN	20'		1						
		30'			1					
STW-JZ 80	JS-080P-BN	20'		1						
		30'			1					
		40'				1				
STW-JZ 110	JS-110P-BN	30'			1					
		40'				1				
		50'					1+		1	
STW-JZ 130	JS-130P-BN	30'			1					
		40'				1				
		50'					1+		1	
STW-JZ 155	JS-155P-BN	40'				1				
		50'					1+		1	
		60'					1+			1
STW-JZ 175	JS-175P-BN	50'					1+		1	
		60'					1+			1
		70'						1+		
STW-JZ 200	JS-200P-BN	50'					1+		1	
		60'					1+			1
		70'						1+		

COMPLETE SYSTEMS: previous page
STW BURNER KITS: next page
TUBE KITS: page T-52
OPTIONAL ACCESSORIES: page T-55



HARSH ENVIRONMENT & OUTDOOR TUBE HEATER STW-JZ & STW-JZ2 Series



BURNER KITS

STAINLESS STEEL BURNER HOUSING

Power Car Wash / Harsh Environment

for Models:

STW-JZ: Aluminized Steel Tubes & Aluminized Steel Reflectors

STW-JZ2: Stainless Steel Tubes & Stainless Steel Reflectors (*longer lead time*)

Btuh CAPACITY	AVAILABLE TUBE LENGTHS	FUEL	INCLUDES FLEX GAS CONNECTOR	ORDER PART #	LIST PRICE*
45,000	10', 20'	N.G.	1/2" X 24"	JS-045P-BN	\$ 1,686.00
60,000	20', 30'	N.G.	1/2" X 24"	JS-060P-BN	1,686.00
80,000	20', 30', 40'	N.G.	1/2" X 24"	JS-080P-BN	1,686.00
110,000	30', 40', 50'	N.G.	1/2" X 24"	JS-110P-BN	1,686.00
130,000	30', 40', 50'	N.G.	1/2" X 24"	JS-130P-BN	1,686.00
155,000	40', 50', 60'	N.G.	3/4" X 36"	JS-155P-BN	1,755.00
175,000 NG	50', 60', 70'	N.G.	3/4" X 36"	JS-175P-BN	1,787.00
NOTE**: 175,000 LP	50', 60', 70'	N.G.	3/4" X 36"	JS-175P-BL	1,787.00
200,000	50', 60', 70'	N.G.	3/4" X 36"	JS-200P-BN	1,787.00

** NOTE: Order 175,000 Btuh Propane burner direct from factory; Product Bulletins provide detail on 175,000 burner conversion

The following items are packed inside the burner kit carton: S/S FLEXIBLE GAS CONNECTOR, Burner fastening nuts & bolts, flange gasket, igniter (mounted), installation manual, fresh air intake cap.

All burner assemblies operate on line voltage (120VAC).

Heaters are shipped and invoiced as burner kits and tube kits. Please order kits.

LPG FIELD CONVERSION KITS FOR STW-JZ BURNERS

	INPUT		PART #	LIST PRICE*
Conversion Kits for LP to NG are listed on page T-52	45,000 Btuh	Field Conversion Kit NG to LP	JS-0556-XC	\$ 46.40
	60,000 Btuh	Field Conversion Kit NG to LP	JS-0557-XX	24.80
	80,000 Btuh	Field Conversion Kit NG to LP	JS-0559-XX	24.80
	110,000 Btuh	Field Conversion Kit NG to LP	JS-0561-XX	24.80
	130,000 Btuh	Field Conversion Kit NG to LP	JS-0563-XX	24.80
	155,000 Btuh	Field Conversion Kit NG to LP	JS-0565-XX	24.80
	175,000 Btuh	Field Conversion Kit NG to LP**	JS-0567-AA	24.80
	200,000 Btuh	Field Conversion Kit NG to LP	JS-0567-CC	24.80

**See NOTE above

Series ->	-JZ	-JZ2	
KIT ASSEMBLY CHART	p. T-43	p. T-46	-JZ2 = Stainless Steel ~ Longer Lead Times
TUBE KITS	p. T-45	p. T-47	

COMPLETE SYSTEMS: page T-49
OPTIONAL ACCESSORIES: page T-55



HARSH ENVIRONMENT & OUTDOOR TUBE HEATER SPW-JZ & STW-JZ Series

TUBE KITS (emissive coated)

ALUMINIZED STEEL TUBES & REFLECTORS

CAR WASH & PATIO TUBE HEATER

Stand-Alone tube kits require no additional tube kits.
Primary tube kits require at least one additional Secondary tube kit.
Secondary tube kit require a Primary tube kit.

Kits include: Tubes, 'JZ' Reflectors, End Plate Hangers, Couplers, Turbulator

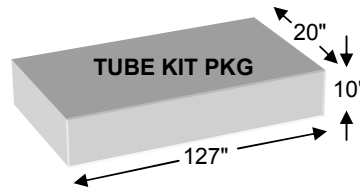

Chain: $((\text{tube length}/10) + 2) \times \text{length}$ at each suspension point
 'S' hooks: $(\text{tube length}/10) \times 2 + 4$

Note: "TS-" part number is correct - this kit has an aluminized steel tube

<u>Stand-Alone</u>	<u>Description</u>	<u>TUBE KIT #</u>	<u>LIST PRICE*</u>
10' : 45,000	One coated flanged/swaged aluminized steel tube with no ports and 5 ft Turbulator	TS-4510-JZ	\$ 442.00
20' : 45/60/80,000	One flanged/swaged tube with no ports, one coated aluminized steel swaged tube, one 4 ft turbulator and one 10 ft turbulator	TW-1420-JZ	607.00
30' : 60/80/110/130	One flanged/swaged tube with no ports, two coated aluminized steel swaged tubes, one 4 ft turbulator and one 10 ft turbulator	TW-1430-JZ	800.00
40' : 80/110/130/155	One flanged/swaged tube with no ports, 3 coated aluminized steel swaged tubes, and one 10 ft turbulator	TW-1040-JZ	1,023.00
Primary Kits [to make (40'), 50', 60' & 70' heaters]			
30' : 110/130/155,000	One flanged/swaged tube with no ports, two coated aluminized steel swaged tubes	TW-F030-JZ	778.00
30' : 175/200,000	One flanged/swaged alumatherm tube with no ports, two coated aluminized steel swaged tube, one 10 ft turbulator	TW-1030-JZ	874.00
Secondary Kits [add to above Primary Kits to make (40'), 50', 60' & 70' heaters]			
20'	Two coated aluminized steel swaged tubes (creates 50 ft heater)	TW-0020-JZ	533.00
30'	Three coated aluminized steel swaged tubes (creates 60 ft heater)	TW-0030-JZ	736.00
40'	Four coated aluminized steel swaged tubes (creates 70 ft heater)	TW-0040-JZ	949.00
10'	One coated aluminized steel swaged tube, and one 10 ft turbulator	TW-1010-JZ	330.00

NOTE: Secondary tube kit TW-1010-JZ can be used with TW-F030-JZ to create a 40 ft kit.
Do not use 10 ft kit to extend heater length beyond the maximum length approved for any input.

KIT ASSEMBLY CHART: pages T-50, T-53
COMPLETE SYSTEMS: pages T-46, T-49
SPW BURNER KITS: page T-48
STW BURNER KITS: page T-51
OPTIONAL ACCESSORIES: page T-55

HARSH ENVIRONMENT & OUTDOOR TUBE HEATER STW-JZ2 Series

BURNER & TUBE KIT ASSEMBLY CHART

MODEL: STW-JZ2: Stainless Steel Tube & Reflector Kits

Food Industry & Extreme Environment Applications

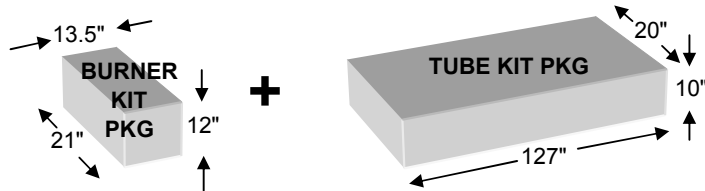

Chain: $((\text{tube length}/10) + 2) \times \text{length}$
at each suspension point
'S' hooks: $(\text{tube length}/10) \times 2 + 4$

		STW-JZ2 TUBE KIT PART # & QUANTITY REQUIRED							
		Stand-Alone Kits				Primary Kits +		Secondary Kits	
Tube Kit Gross Weight (lbs) ->		70	120	170	210	165	165	120	165
Tube Kit Nominal Length ->		10'	20'	30'	40'	30'	30'	20'	30'
BURNER KIT (includes S/S Flex Gas Connector) Gross Wt = 30 lb		TW-4510 -JZ2	TW-1420 -JZ2	TW-1430 -JZ2	TW-1040- JZ2	TW-F030 -JZ2	TW-1030 -JZ2	TW-0020 -JZ2	TW-0030 -JZ2
MODEL									
STW-JZ2 45	JS-045P-BN	10'	1						
		20'		1					
STW-JZ2 60	JS-060P-BN	20'		1					
		30'			1				
STW-JZ2 80	JS-080P-BN	20'		1					
		30'			1				
STW-JZ2 110	JS-110P-BN	40'			1				
		50'				1+		1	
STW-JZ2 130	JS-130P-BN	30'		1					
		40'			1				
STW-JZ2 155	JS-155P-BN	50'				1+		1	
		60'				1+			1
STW-JZ2 175	JS-175P-BN	50'					1+	1	
		60'					1+		1
STW-JZ2 200	JS-200P-BN	70'					1+	2	
		50'					1+	1	
		60'					1+		1
		70'					1+	2	

Stand-Alone tube kits require no additional tube kits.
 Primary tube kits require at least one additional Secondary tube kit.
 Secondary tube kit require a Primary tube kit.

COMPLETE SYSTEMS: page T-49
 STW-JZ BURNER KITS: page T-51
 STW-JZ2 TUBE KITS: next page
 OPTIONAL ACCESSORIES: page T-55



HARSH ENVIRONMENT & OUTDOOR TUBE HEATER STW-JZ2 Series

'-JZ-2' TUBE KITS

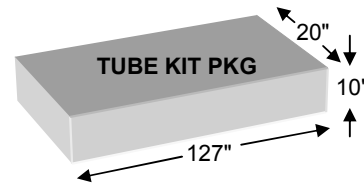

STAINLESS STEEL REFLECTORS + STAINLESS STEEL TUBES

Longer Lead Times for Stainless Steel Tube Kits

Stand-Alone tube kits require no additional tube kits.

Primary tube kits require at least one additional Secondary tube kit.

Secondary tube kit require a Primary tube kit.

Each kit includes Stainless Steel: Tubes, 'JZ-2' Reflectors, Webbed S/S hanger system, Tube Couplers, Turbulator(s) as required

<u>Stand-Alone</u>		<u>TUBE KIT #</u>	<u>LIST PRICE*</u>
10' : 45,000 Btuh	One flanged/swaged S/S tube with no ports, one 5 ft turbulator	TW-4510-JZ-2	\$ 1,130.00
20' : 60,000/80,000	One flanged stainless steel swaged tube with no ports + one S/S swaged tube, one 4 ft turbulator and one 10 ft turbulator	TW-1420-JZ-2	1,951.00
30' : 60/80/110/130,000	One flanged stainless steel swaged tube with no ports + two S/S swaged tubes, one 4 ft turbulator and one 10 ft turbulator	TW-1430-JZ-2	2,846.00
40' : 80/110/130/155,000	One flanged stainless steel swaged tube with no ports + 3 S/S swaged tubes, and one 10 ft turbulator	TW-1040-JZ-2	3,731.00
<u>Primary Kits</u> [to make (40'), 50', 60' & 70' heaters]			
30' : 110/130/155,000	One flanged stainless steel swaged tube with no ports, two stainless steel swaged tubes	TW-F030-JZ-2	2,793.00
30' : 175/200,000	One flanged stainless steel swaged tube with no ports, two stainless steel swaged tubes, one 10 ft turbulator	TW-1030-JZ-2	2,793.00
<u>Secondary Kits</u> [add to above Primary Kits to make (40'), 50', 60' & 70' heaters]			
10'	One stainless steel swaged tube, and one 10 ft turbulator	TW-1010-JZ-2	1,055.00
20'	Two stainless steel swaged tubes	TW-0020-JZ-2	1,876.00
30'	Three stainless steel swaged tubes	TW-0030-JZ-2	2,783.00

KIT ASSEMBLY CHART: previous page

COMPLETE SYSTEMS: page T-49

STW BURNER KITS: page T-51

OPTIONAL ACCESSORIES: page T-55



OPTIONAL ACCESSORIES - Page 1 of 3

SPW-JZ, STW-JZ, STW-JZ2 TUBE HEATERS

More Options: Next pages.



IMPORTANT: TUBE HEATER GAS CONNECTION - JUNE 2009

ANSI Z83.20-2008 / CSA 2.34-2008

New Standard for Gas-Fired Low-Intensity Infrared Tube Heaters

requires the mandatory supply of specific gas connector by the manufacturer:

USA : A S/S FLEXIBLE Gas Connector IS SUPPLIED with Tube Heater:

Note: Minimum length for tube heater flexible connector is 24 inches.

Refer to table below for correct sized connector that is supplied and must be installed.

Gas connector is shipped in the Burner Kit carton

Mandatory S/S Flex Gas Connector	
Input Btuh	Required ID x Length
45,000	1/2" x 24"
60,000	1/2" x 24"
80,000	1/2" x 24"
100,000	1/2" x 24"
110,000	1/2" x 24"
130,000	1/2" x 24"
155,000	3/4" x 36"
175,000	3/4" x 36"
200,000	3/4" x 36"

Flexible Gas Connectors:

S/S FLEXIBLE - Replacement Parts

S/S FLEXIBLE Connector 1/2" X 24" - for 45,000 up to 155,000 Btuh
JL-0771-XX \$33.00

S/S FLEXIBLE Connector 3/4" x 36" - for 175,000 up to 200,000 Btuh
JL-0771-YY 102.00

NOTE: These items are not available from Schwank in stainless steel

Hanging Chain:

#2 Lion Chain - 115 lb work load - 200 ft roll



	<u>PART #</u>	<u>LIST PRICE</u>
#2 Lion Chain - 115 lb work load - 200 ft roll	JL-0800-XX \$	97.00

#8 Jack Chain - 60 lb work load - 50 ft box



#8 Jack Chain - 60 lb work load - 50 ft box	JL-0798-JC \$	60.00
---	---------------	-------

Quantity of Chain required: { -JZ Series heater = ((heater tube length/10) + 2) x length of chain at each suspension point
ie: SPW-JZ 40 ft heater 3 ft below structural support = ((40/10) + 2) x 3 = 18 ft of chain

Safety Snap Hooks - 2"



Package of 24	JL-0800-SH	40.20
Package of 100	JL-0800-SH-B	123.00

'S' Hooks - 1 7/8" - Package of 25

Quantity of 'Snap' or 'S' Hooks: -JZ Series quantity required = ((tube length/10) x 2) + 4 : ie: SPW-JZ x 40 ft = (40/10) x 2) + 4 = 12 hooks

'S' Hooks - 1 7/8" - Package of 25	JL-0798-SH	23.20
------------------------------------	------------	-------

CLEARANCE TO COMBUSTIBLES SIGN

Metal sign - 18" x 6"
- 3/4" red lettering on white background



CLEARANCE TO COMBUSTIBLES SIGN	JL-0798-CS	37.10
--------------------------------	------------	-------



OPTIONAL ACCESSORIES - Page 2 of 3 SPW-JZ, STW-JZ & STW-JZ2 TUBE HEATERS

Note: Stainless Steel accessories have longer lead times

Control Options:

ThermoControl Plus

- Building Management System
(°F & °C scales)



See more info on the
ThermoControl Plus on
pages T-57 & T-58

Moisture Proof Thermostat (NEMA 4X Enclosure)



PART #	LIST PRICE
JS-0570-XX	\$ 341.00

Vent Stuff



Wall Terminal*

Flue Vent Terminals:

- 4" horizontal (through wall)
- 6" horizontal

PART #	LIST PRICE
JA-0528-XX	\$ 39.50
JA-0529-XX	48.00

- Vent Tee 4" X 4" X 6"
(Two Couplers JA-0516-AA are optional)



JA-0514-XX	197.00
------------	--------

Optional Couplers for Vent Tee:

- 4" x 8" Aluminized Steel Coupler with 2 x U-Bolts
(ADD TWO optional tube couplers JA-0516-AA or JA-0516-XX if desired for vent pipe connection to Tee)

JA-0516-AA	41.70
------------	-------

HORIZONTAL VENTING: Use the 'Wall' termination cap by Schwank, or use an approved 'High Wind' termination cap

VERTICAL VENTING: Use the termination cap for double walled pipe as supplied by the vent pipe manufacturer

* Fits single wall vent pipe - field modification required to fit to double wall pipe

- 4" swaged Tube Coupler (required quantity is shipped with heater)
- Also available in stainless steel

JA-0516-SW	41.70
JA-0516-SS	29.90



OPTIONAL ACCESSORIES - Page 3 of 3

SPW-JZ, STW-JZ & STW-JZ2 TUBE HEATERS

ST-JZ Elbow Kits:

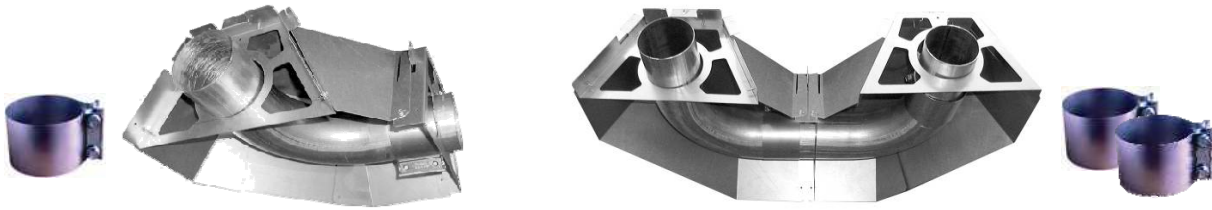

ST-JZ 90° Aluminized Steel Elbow & Reflector Cover Kit: <i>(Elbow can be installed right or left hand - Includes Coupler, Reflector Cover, Hanger Plate)</i>	JS-0508-JZ	\$	160.00
ST-JZ 180° Elbow & Reflector Cover Kit: ORDER: TWO x 90° ELBOW KITS	Qty 2 x JS-0508-JZ		320.00
STW-JZ2: 90° Stainless Steel Elbow & Reflector Cover Kit: <i>(Longer lead time)</i>	JS-0508-JZ-2		416.00
For 180° Elbow Kits = Combine TWO JS-0508-JZ(-2) Kits as Required			

➔ **Reflector Angle Adapter** - one required each juncture of angle change JS-0504-JZ \$ 15.60

NOTE: The elbow reflector cap must always be in the same plane as the elbow - cap cannot be angled independently
The Reflector Angle Adapter is required for angle mounting a reflector section before or after an elbow
Or for mounting of a reflector section at an independent angle relative to the other reflectors in the system.

Other Optional Accessories:

Decorative 'Tuxedo' Grille Kit - Matte Black Finish

Dress up your tube heater installations.

- Ideal for:
- Patios
 - Retail areas
 - Showrooms



Matte black grille & aluminized steel framing secures with tabs to 'JZ' Series heater reflectors. *(Not for S100 Series)*

Decorative 'Tuxedo' Grille Kit - 10 ft - Matte Black Grille *Each 10 foot section* TG-0010-KT \$ 360.00

Reflector Side Extension Extension

- All models - 10" deep x 116" long c/w Qty 3 x 'S' hooks

JS-0509-KT 47.00

Tube Protection Screen '-JZ' Tube Kit - 5 ft length

*(1/2" x 1/2" galvanized screen)
(custom order: longer lead time)*

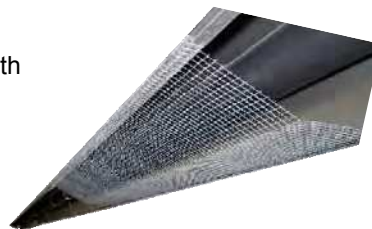

JA-0780-XX 60.00



NEW

Payback in less than one year with typical energy savings



- 'Smart' adaptive recovery
- Single or Two-Stage system control
- Easy set up and configuration
- 8 programmable holiday periods
- Locking cover
- NEMA 13 enclosure
- IR sensor can be installed indoors or outdoors
- Coming soon ... RS232/485 interface
 - CM232 includes BMS software
 - CM485 communicates with existing BMS

THERMOCONTROL PLUS 1 - 1 to 2 ZONE	JM-0504-TK-1
- Control: One or two Single-Stage Zones; or one Two-Stage Zone	<u>Qty</u>
Includes ThermoControl Outdoor Air Temperature Sensor	1
24V Transformer 100VA (24Vac powers the control & relays)	1
24V External Relay* to switch 120Vac power to heaters	2

THERMOCONTROL PLUS 2 - 1 TO 4 ZONE	JM-0504-TK-2
- Control: up to four Single-Stage Zones, or two Two-Stage Zone	<u>Qty</u>
Includes ThermoControl Outdoor Air Temperature Sensor	1
24V Transformer 100VA (24Vac powers the control & relays)	1
24V External Relay* to switch 120Vac power to heaters	4

THERMOCONTROL PLUS 4 - 1 TO 8 ZONE	JM-0504-TK-4
- Control: up to eight Single-Stage Zones, or four Two-Stage Zone	<u>Qty</u>
Includes ThermoControl Outdoor Air Temperature Sensor	1
24V Transformer 100VA (24Vac powers the control & relays)	1
24V External Relay* to switch 120Vac power to heaters	8

Refer to chart and guidelines next page:
Zone Schemes and Component Quantity

Call your local Schwank representative for project design and pricing of the ThermoControl Plus

The supplied 24Vac 100VA transformer powers the control panel and external relays at each heater zone.

* **RELAY SWITCH**: an additional two relays are required for each 2-stage tube heater **JS-0568-CC**
a sufficient quantity of relays supplied with control for single-input tube heaters

IR Sensor Required : ThermoControl RADIANT SENSOR **JM-0505-XX**
- Minimum one required per zone, or for 'temperature averaging' four required per zone

Optional: SETBACK OVERRIDE Push Button Switch **JM-0509-XX**

more information next page ...

ThermoControl Plus

.... continued

Schwank
INNOVATIVE HEATING SOLUTIONS



IR Sensor
Order separately

- IR sensor senses and averages radiant and ambient temperatures for true comfort control
- Indoor or outdoor installation
- Use one sensor per zone, or use four to get temperature averaging
- Outdoor air temperature sensor included with control for 'smart' adaptive recovery

Zone Schemes and Component Quantity

CONTROLLER	ORDER PART #	Zone Control Combinations		Total Number of Zones	ALSO ORDER:		
		Single Stage	Two Stage*		RADIANT SENSORS JM-0505-XX		Optional Setback Override JM-0507-XX
					Minimum 1 per Zone	OR Temperature Averaging	
ThermoControl Plus 1	JM-0504-TK-1	2	-	2	2	8	2
		1	-	1	1	4	1
		1	1	2	2	8	2
ThermoControl Plus 2	JM-0504-TK-2	4	-	4	4	16	4
		3	-	3	3	12	3
		2	1	3	3	12	3
		1	1	2	2	8	2
ThermoControl Plus 4	JM-0504-TK-4	8	-	8	8	32	8
		7	-	7	7	28	7
		6	-	6	6	24	6
		6	1	7	7	28	7
		5	-	5	5	20	5
		5	1	6	6	24	6
		4	2	6	6	24	6
		2	3	5	5	20	5
		1	3	4	4	16	4
-	4	4	4	16	4		

* Two-Stage Zone: Control either two-stage heaters

OR single-stage heaters with 50% or more heaters in Stage 1, balance in Stage 2

Guidelines:

1. ThermoControl Plus controllers have 24Vac 'wet' contacts. Call for heat activates 24Vac to external power relays
2. **Single-input Tube Heaters:** A sufficient quantity of External Power Relays are supplied with the ThermoControl Plus to switch 120Vac to single-input Tube Heaters in each of the zones
3. **2-Stage Tube Heaters:** Order an additional quantity of TWO relays (JS-0568-CC) for each 2-stage tube heater
4. Zone Sizes: Tube heaters - Up to 10 heaters per zone (*capacity of relay switch*)

See Luminous Heater section for information on controlling luminous heaters with the ThermoControl Plus

SP-LTUB-IX-01A
RD: APR 2011
RL:USA - 11-1A
BA



TruTemp

Infrared Setback Thermostat



SCHWANK TruTemp INFRARED SETBACK THERMOSTAT

NOT FOR USE IN WET ENVIRONMENTS

The only infrared thermostat that senses and averages radiant and ambient temperatures for true comfort control and efficient heating system operation. An automatic setback feature further adds to fuel savings when the heated space is unoccupied. Controls a Schwank heating system to provide true comfort levels. TruTemp thermostat can be used in conjunction with all Schwank heaters. 4" Diameter fits standard electrical box

<u>MODEL</u>	<u>VOLTAGE</u>	<u>PART #</u>	<u>LIST PRICE</u>
TruTemp Thermostat	24 Volts	JM-0150-XX	\$ 213.00

FIELD MOUNTED OPTIONS REQUIRED WITH TruTemp THERMOSTAT

- SINGLE STS-JZ TUBE HEATER & SINGLE TruTemp

<u>ORDER</u>		<u>PART #</u>	
1	TruTemp Thermostat	JM-0150-XX	\$ 213.00

- SINGLE S100 SERIES TUBE HEATER & SINGLE TruTemp

ORDER TruTemp +

<u>ORDER</u>		<u>PART #</u>	
1	S100 24V Control Option	JS-0568-KT	\$ 37.40

(Relay Switch Field Mounts in burner on Control Plate)



- MULTIPLE TUBE HEATERS & SINGLE TruTemp (Up To 7 STS-JZ or S100 Heaters per Zone)

ORDER TruTemp +

<u>ORDER</u>		<u>PART #</u>	
1	24V Transformer/Relay Option	JM-0303-KT	\$ 107.00

(Transformer/Relay & Accessories)

(Field Mounts on exterior of a burner housing)

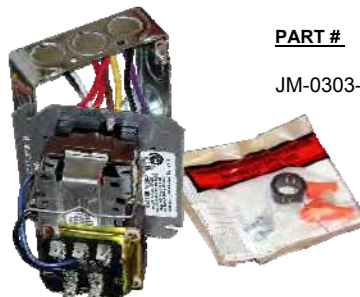

SECURITY OPTION TO PREVENT UNAUTHORIZED TAMPERING

Two S/S Tamperproof Screws and One Tool <i>(Order for the first TruTemp on project)</i>	JM-0180-XX	\$ 65.00
Two S/S Tamperproof Screws <i>(Order for each Additional TruTemp on project)</i>	JM-0180-AA	6.50



ThermoControl Plus Guidelines for Tube Heaters

1. ThermoControl Plus controllers have 24Vac 'wet' contacts = sends 24Vac signal to external power relays
2. A sufficient quantity of External Power Relays are supplied with the ThermoControl Plus to switch 120Vac to Tube Heaters in each of the zones
3. Zone Sizes: Tube heaters - Up to 10 heaters per zone
4. No additional control centers or relays are required

TUBE HEATER 24V CONTROL OPTION GUIDELINES

for: TruTemp / 24V Thermostat / patioPanel / Remote Control

SCHWANK TUBE HEATERS: Single heater per control zone

UHE, STS-JZ, STV-JZ, SPW-JZ & STW-JZ (for multiple heaters per zone - see below)

Single HEATER per Single TruTemp / 24V THERMOSTAT / patioPanel switch* / Remote Control

- 120 V supply is ALWAYS required to the burner to power the blower and the individual transformer in each burner assembly, regardless of the thermostat or control voltage.
- 24V power to the thermostat is supplied by the transformer within the heater
- A 24V/120V relay switch is factory installed in the burner

***ORDER** - Any 24 volt thermostat or TruTemp supplied by Schwank will control a single burner of models above

- **patioPanel:** 24V power to the panel switch is supplied from the transformer within the burner
ONLY ONE tube heater can be controlled by each patioPanel switch
- **Remote Control:** Each Burner is ready for installation of Remote Control Receiver Kit: JP-1234-RK
- Refer to patio heater section for information on Remote Control options
- Existing Tube heaters in the field (made prior to May 1, 2006) require the installation of optional kits:
 - JS-0568-KT 24V Relay Kit: For heaters with 24V Transformer in burner (ST Series)
 - JM-0568-KT 24V Transformer-Relay Kit: For heaters without 24V Transformer in burner (SE Series)

S100 Builder Series (for multiple heaters per zone - see below)

Single HEATER per Single TruTemp or 24V THERMOSTAT

- 120 V supply is ALWAYS required to the burner to power the blower and gas and ignition controls
- 24 V Relay Kit JS-0568-KT (field mount in burner) is required to control a single heater using a low voltage thermostat

TUBE HEATERS: 2 to 7 heaters per control zone

ALL MODELS (for single heater per zone - see above)

MAXIMUM 7 HEATERS PER ZONE / ORDER Transformer-Relay KIT JM-0303-KT

- 120V supply is ALWAYS required to the burner to power the blower and controls
- The Transformer-Relay is factory mounted in an electrical enclosure; the kit is field installed
- The Transformer-Relay Kit may be mounted on or in near proximity to the heater(s) or thermostat
- NO ADDITIONAL 24V OPTION is required within the burner(s)
- 24V power is provided to the thermostat by the transformer within the Transformer-Relay Kit
- The thermostat call-for-heat closes the relay within the Transformer-Relay
- The 'closed' relay provides 120V to the heater(s) in the zone

ORDER: Transformer-Relay Kit JM-0303-KT + a Thermostat (24 Volt OR TruTemp)

LUMINOUS HEATER 24V GUIDELINES are on page L-14



GAS CONVERSION KITS SCHWANK TUBE HEATERS

*NOTE: Conversion kits are NOT available for: JP tube heaters and Models BR-85, BR-100 - Contact Schwank
When ordering, please provide **complete Model Number** (see CSA label) and Gas Type to convert to*

<u>Complete Model # Required</u>	<u>Input</u>	<u>NG to LP</u>	<u>LP to NG</u>	<u>List Price</u>
Discontinued 45,000 Btuh model numbers:				
STS, STS-JZ, STR, STR-JZ, SER	45,000	JS-0556-XA	JS-0556-XB	\$ 46.40
Current 45,000 Btuh model numbers:				
STS-JZ-X1, STR-JZ-X1, SPW-JZ, STW-JZ	45,000	JS-0556-XC	JS-0556-XD	46.40
S100, S100U	45,000	JS-0556-XE	JS-0556-XF	36.10

	<u>Input</u>	<u>NG to LP</u>	<u>LP to NG</u>	
STS-JZ, STS _{sp} , STS	60,000	JS-0557-XX	JS-0558-XX	24.80
STR-JZ, STR		JS-0559-XX	JS-0560-XX	24.80
STW-JZ, STW, STS-WP	100,000	Available in NG ONLY		
SPW-JZ	110,000	JS-0561-XX	JS-0562-XX	24.80
STV-JZ, STSV	130,000	JS-0563-XX	JS-0564-XX	24.80
S100	155,000	JS-0565-XX	JS-0566-XX	24.80
SEM-CH* (Honeywell 120V Valve)	175,000	JS-0567-AA**	JS-0567-BB	24.80
	200,000	JS-0567-CC	JS-0567-DD	24.80

****NOTE: Order new 175,000 LP burner direct from factory - do not order conversion kit**

		<u>NG to LP</u>	<u>LP to NG</u>	
SET	80/60,000	JS-0555-TC	JS-0555-TD	42.30
2-STAGE	110,75,000	JS-0555-TG	JS-0555-TH	42.30
	130/90,000	JS-0555-TK	JS-0555-TL	42.30
	155/130,000	JS-0555-TO	JS-0555-TP	42.30

	<u>Input</u>	<u>NG to LP</u>	<u>LP to NG</u>	
ATH	60,000	JS-0557-LS	JS-0558-NS	\$ 48.00
SEB	80,000	JS-0559-LS	JS-0560-NS	48.00
SER: 60,000	110,000	JS-0561-LS	JS-0562-NS	48.00
SEM-CA* (Robertshaw 120V Valve)	130,000	JS-0563-LS	JS-0564-NS	48.00
	155,000	JS-0566-LS	JS-0566-NS	48.00
	175,000	JS-0567-LS	JS-0567-NS	48.00
	200,000	JS-0567-LI	JS-0567-NI	48.00

* SEM Model 'dash number'

<u>PRT Series</u>	<u>Input</u>	<u>NG to LP</u>	<u>LP to NG</u>	
PRT 60	60,000	JT-0941-TA	JT-0940-TA	No longer available
PRT 80	80,000	JT-0941-TB	JT-0940-TB	No longer available
PRT 100	100,000	JT-0941-TC	JT-0940-TC	No longer available



Schwank
INNOVATIVE HEATING SOLUTIONS



RESIDENTIAL & PATIO HEATER USA PRICE LIST 2011

PRICES IN EFFECT APRIL 1, 2011

Release 11-1A - see "What's New" page 6

Schwank Group

2 Schwank Way, P.O. Box 988
Waynesboro, GA 30830-0988

5285 Bradco Blvd
Mississauga, Ontario. L4W 2A6

Orders, Customer Service & Technical Support

1-877-446-3727

Fax: 1-866-361-0523

Design Services

USA Fax: 1-866-361-0523

design@schwankgroup.com



Inquiry email: csr@schwankgroup.com

Visit our website for current product information

www.patioSchwank.com

Select **PUBLISHED INFO** from menu, then Register or Login

These price sheets are the proprietary information of Schwank. This publication, or parts thereof, may not be reproduced in any form or reposted electronically without prior written consent from Schwank. Unauthorized use or distribution is strictly prohibited.





All Schwank heaters are certified by CSA International

As of the effective date, these price sheets supercede all previous price sheets.



TABLE OF CONTENTS

	Credit Terms & Returns Policy	P-4
	USA Freight Zone Adders	P-5
	What's new for 2011	P-6
RESIDENTIAL & WORKSHOP	ecoSchwank-M Millivolt Series High Intensity Heaters	P-7
	Other Accessories for ecoSchwank-M High Efficiency Heaters.....	P-8
	STR-JZ Workshop/Garage Tube Heater Complete Systems & Kit Assembly Chart	P-9
	STR-JZ Burner Kits; Tube Kits; Gas Conversion Kits.....	P-10
	STR-JZ Accessories.....	P-11
	Patio Heater Selection Guidelines	P-12
CONTROLS	REMOTE CONTROL & patioPanel ~ Central control of heating systems	P-13
	- 24V Option Guidelines	P-13
	 ThermoControl Plus Management System	P-14
	Transformers for 2300 Series Luminous Heaters	P-16
LUMINOUS	sportSchwank Outdoor Venue Heaters	P-17
	patioSchwank 2300 Series Luminous Heaters & Accessories	P-18
TUBE HEATERS <i>Great under Canopy & Roof</i>	patioSchwank 3000 Series* ~ Best under Roof / Canopy or Enclosed Patios	P-19
	Model SPW-JZ Tube Heaters - Powder Coated Cabinet	P-19
	SPW-JZ Assembly Chart: Burner & Tube Kits	P-20
	SPW-JZ Burner Kits - Powder Coated Cabinet.....	P-21
	SPW-JZ Tube Kits	P-22
	Model STW-JZ Tube Heaters - Stainless Steel Cabinet for Coastal Regions....	P-23
	STW-JZ Assembly Chart: Burner & Tube Kits	P-24
	STW-JZ Burner Kits - Stainless Steel Cabinet.....	P-25
	STW-JZ Tube Kits	P-26
	Optional Accessories for SPW-JZ & STW-JZ Series Tube Heaters	P-27
PARASOL STYLE	patioSchwank 4000-CB Series Portable Heaters & Accessories	P-29
	patioSchwank 4000-CB Series Fixed Mount Heaters & Accessories	P-30
	 patioSchwank 4000-CB-24 Series Fixed Mount Heaters 24V Ignition	P-31
ELECTRIC IR 	IEP Series Short-Wave Infrared Heaters - Instant Comfort	P-32
	Gas Conversion Kits for patioSchwank 1100, 2300, & 3000 Series Heaters	P-33
	Product Warranty Summary	P-34
	Patio Heating Design Survey Sheet - copy, complete and fax in	P-35

** Please order 3000 Series heaters as burner kits + tube kits
Tube heaters are shipped & invoiced as burner kits & tube kits*

F.O.B. Mississauga, Ontario
All Applicable Taxes Extra
1% Monthly Interest On Overdue Accounts
Prices subject to change without notice

These price sheets supercede all other preceding price sheets

Credit Terms

When credit is extended by Schwank the terms are: Net 30 days

1% Monthly Interest On Overdue Accounts

Minimum Invoice: A minimum order of \$50.00 is required for invoicing

patioSchwank Returns Policy

The complete 'Returns Policy' is available from Customer Service, or at www.patioSchwank.com in the "Published Info" area.

Approval must be issued in advance by Schwank before any returns will be accepted.

All goods being returned must be accompanied by a completed Return Authorization form.

Schwank reserves the right to disallow the return of sold goods.

Warranty Returns

SCHWANK is proud of the quality of the products we distribute through your Organization; Some product components do fail occasionally. If this occurs, the following procedure must be followed:

- 1** Heater MODEL # & SERIAL # are required for any technical services contact
- 2** Contact SCHWANK to be issued a Return Authorization form
- 3** If you wish to return a product for "advance warranty replacement", SCHWANK will send the Return Authorization Form to you along with the advance replacement product(s). This form must be completed and returned to SCHWANK along with the product(s), shipping "Prepaid" - Schwank will refuse "Collect" shipments. At SCHWANK's discretion, SCHWANK may instruct you to field scrap the failed part. In such case, the Return Authorization Form must still be completed and returned to SCHWANK by fax or mail
- 4** Upon receipt of the product and/or the Return Authorization Form, SCHWANK will determine if credit is warranted
 - P** if credit is warranted, a credit notice will be issued
 - P** if credit is not warranted, an explanation of credit rejection will be sent to you. Unless advised otherwise, the product will be held for 30 days and then scrapped

Restocking Returns

If an item is to be returned to Schwank stock for credit within 30 days of purchase:

- 1** Contact SCHWANK customer service to be issued a Return Authorization Form
- 2** SCHWANK will forward a Return Authorization Form to you. This form must be completed and returned to SCHWANK along with the product(s), shipping "Prepaid" - "Collect" shipments will be refused. The original invoice number must be indicated on the Return Authorization Form
- 3** Returned items must be in "new condition" and in original packaging / carton
- 4** Upon receipt of the product and the Return Authorization Form, SCHWANK will determine credit amount based upon:
 - a.** items returned to Schwank stock are subject to a 25% restocking charge
 - b.** damaged items will result in a credit deduction for any repair costs, or no credit value

Charge Backs

Heater must be properly commissioned and the Commissioning Form accurately completed and returned to Schwank. A Commissioning Form is located near the back of the I&O Manual supplied with each heater.

All charge back claims must be approved in writing by Schwank Technical Services prior to commencement of work.

Freight Charges

USA FREIGHT ZONES Page G-5



USA FREIGHT ZONES & CHARGES

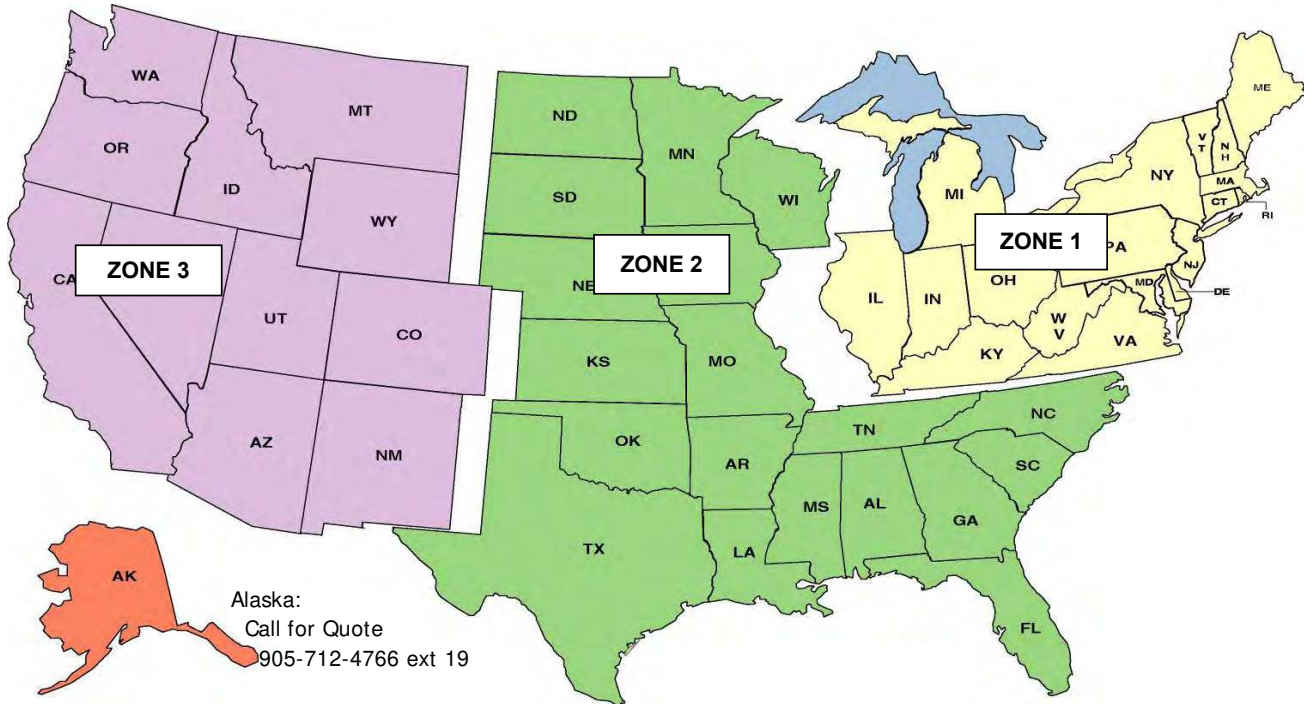

At your request, Schwank will ship any product via your account with any shipper. Please include contact information for your shipper when placing your order.

If you wish to ship "Prepaid & Charge" and have Schwank arrange shipment, please refer to the following freight conditions and charges:

Shipments from our Mississauga facility are subject to the charges listed below. Freight charges are based on current LIST PRICING and single destination shipments within a freight zone. All brokerage charges are included. Freight carrier and routing shall be selected by Schwank. All freight charges will be prepaid and added to your invoice.

<u>Total LIST PRICE (USD)</u>	<u>Zone</u>	<u>Freight Charge Based On LIST PRICE</u>
\$10,000 and OVER	#1	0%
\$5,000 to \$9,999	#1	3%
\$100* to \$4,999.	#1	4%
\$15,000 and OVER	#2	0%
\$7,500 to \$14,999	#2	4%
\$100* to \$7,499.	#2	5%
\$20,000 and OVER	#3	0%
\$10,000 to \$19,999	#3	5%
\$100* to \$9,999.	#3	6%

* Minimum Freight Charges: Transport Truck \$100 ; Parcel Service charges apply to smaller parts orders;
Minimum Order: \$100 LIST; \$50 NET



What's New for 2011?

NEW In Release 11-1A - April 1, 2011

Please update your sales information and database with this information!

NEW

Electric Short-Wave IR Heaters

- page 32

- *Filp a switch for instant comfort*
- *1500, 2000, 3000 & 6000 Watts*
- *Indoor and Outdoor/Indoor models*
- *Ideal for:*
 - *Enclosed or canopy covered patios*
 - *'Tight' spots*
 - *Longer gas pipe runs are impractical*

NEW

Post Mount Parasol with 24V Ignition

- page 30

- *Filp a switch for central or local control of parasol heaters*
- *Stainless steel or hammered black finish*
- *Permanent post mount*
- *38,000 Btuh conical burner uses 16% less fuel than other models*

NEW

ThermoControl Plus - page 15

- *Comfort control & economy of operation for outdoor IR heating*
- *IR sensor can be installed indoors or outdoors*
- *NEMA 13 enclosure*
- *Locking cover*
- *Easy set up and configuration*

Reminder

sportSchwank - page 18

- *Comfort in outdoor venues - concerts, shopping, and stadiums*

www.patioSchwank.com - *Get current Published Info for all products*



Consult your local & national codes for acceptable application of this millivolt heater

No electrical connection required

Typical accessories are listed below.

Other accessories: next page

ecoSchwank-M Millivolt SERIES

LUMINOUS (High Intensity) HEATERS

ECO-M heaters include assembled reflectors, gas valve, millivolt ignition, digital thermostat & 20 ft thermostat wire. Optional accessories are listed below, and on next page.

<u>MODEL</u>		<u>CAPACITY</u>	<u>GAS</u>	<u>PART #</u>	<u>LIST PRICE</u>
ecoSchwank-M 6	N or L	21,500 Btuh	NG	EC-M025-NG	\$ 752.00
			LP	EC-M025-LP	752.00
ecoSchwank-M 10	N or L	35,000 Btuh	NG	EC-M037-NG	801.00
			LP	EC-M037-LP	801.00
ecoSchwank-M 13	N or L	50,000 Btuh	NG	EC-M050-NG	929.00
			LP	EC-M050-LP	929.00
ecoSchwank-M 18	N or L	71,500 Btuh	NG	EC-M075-NG	1,029.00
			LP	EC-M075-LP	1,029.00
ecoSchwank-M 26	N or L	100,000 Btuh	NG	EC-M100-NG	1,137.00
			LP	EC-M100-LP	1,137.00

OPTIONAL ACCESSORIES FOR ECO-M SERIES

	<u>PART #</u>	<u>LIST PRICE</u>
Flexible Gas Connector 1/2" x 18" (Up to 155,000 Btuh)	JL-0771-FF	\$ 25.70
Flexible Gas Connector 1/2" x 24" (Up to 155,000 Btuh)	JL-0771-XX	33.00
#8 Hanging Chain - box 50'	JL-0798-JC	60.00
'S' Hooks - Package of 25	JL-0798-SH	23.20
Pressure Equalizer Venturi Cover (for Drafty Areas)	JO-0368-XX	160.00



ecoSchwank-M Millivolt SERIES

OTHER ACCESSORIES

Typical Accessories: previous page

TILE PROTECTING GRILLE:

(1/2" X 1/2" Bird Screen)

	<u>PART #</u>	<u>LIST PRICE</u>
For: ecoSchwank-M 6	JX-0249-XX	\$ 26.70
ecoSchwank-M 10	JX-0252-XX	26.70
ecoSchwank-M 13	JX-0253-XX	34.20
ecoSchwank-M 18	JX-0254-XX	44.90
ecoSchwank-M 26	JX-0255-XX	52.00

CEILING PROTECTION PLATE: *Longer lead times for this accessory*

For: ecoSchwank-M 6 & 10	Uninsulated	JX-0256-UN	\$ 128.00
ecoSchwank-M 13	Uninsulated	JX-0257-UN	149.00
ecoSchwank-M 18	Uninsulated	JX-0258-UN	202.00
ecoSchwank-M 26	Uninsulated	JX-0259-UN	246.00

REFLECTOR EXTENSIONS

For: ecoSchwank-M 6	Single	JX-0260-SG-P	\$ 42.70
	Pair	JX-0260-PR-P	85.40
ecoSchwank-M 10	Single	JX-0236-SG-P	42.70
	Pair	JX-0236-PR-P	85.40
ecoSchwank-M 13	Single	JX-0237-SG-P	59.00
	Pair	JX-0237-PR-P	118.00
ecoSchwank-M 18	Single	JX-0238-SG-P	87.00
	Pair	JX-0238-PR-P	174.00
ecoSchwank-M 26	Single	JX-0239-SG-P	128.00
	Pair	JX-0239-PR-P	256.00



STR-JZ Series

RESIDENTIAL GARAGE/SHOP HEATER



STR-JZ SERIES HEATER
includes a 24 volt thermostat

PRICES INCLUDE BURNER ASSEMBLY AND THE FOLLOWING COMPONENTS:

BURNER KIT: STAINLESS STEEL FLEX GAS CONNECTOR, AIR INTAKE HOOD, 120V 3-PRONGED PLUG, AND 24V THERMOSTAT WITH 20 FT OF 18/2 WIRE;

TUBE KIT: PRIMARY TUBE, EMISSIVE COATED SECONDARY TUBE(S), TWO END PLATE HANGERS, WEBBED REFLECTOR/TUBE HANGERS, FOCUS SHIELD REFLECTORS, TUBE COUPLER(S), TURBULATOR(S),

COMPLETE SYSTEMS:

MODEL	CAPACITY		AVAILABLE TUBE		LIST PRICE
			LENGTH		
STR-JZ 45	45,000 Btuh	NG	10'	\$	1,350.00
			20'		1,474.00
STR-JZ 60	60,000 Btuh	NG	20'		1,474.00
			30'		1,670.00

Individual burner kits + tube kits are shipped to assemble tube heater orders.
~ See next page for details ~

Burners are stocked in natural gas only - **Field conversion kit required for LP - see next page**

Heaters are shipped and invoiced as burner kits and tube kits. Please order kits.

STR-JZ BURNER & TUBE KIT ASSEMBLY CHART

MODEL	BURNER KIT (Includes S/S Flexible Gas Connector) Gross Wt = 30 lbs	Nominal Length (ft)	STR-JZ TUBE KIT PART # & QUANTITY REQUIRED		
			Stand-Alone Kits Only		
	Tube Kit Gross Weight (lbs)		70	120	170
STR-JZ 45	JS-R045-AN	10'	1		
		20'		1	
		30'			1
STR-JZ 60	JS-R060-AN	20'		1	
		30'			1

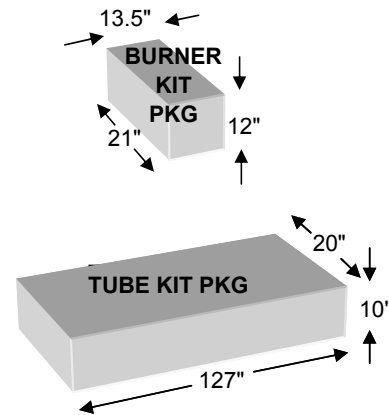

Heaters are shipped and invoiced as burner kits and tube kits. Please order kits.

STR-JZ BURNER & TUBE KITS: next page
STR-JZ ACCESSORIES: page P-15



STR-JZ Series Residential Tube Heater

BURNER KITS - STR-JZ

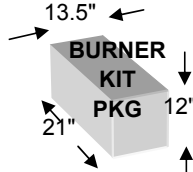

A flexible gas connector is now required to be supplied by the manufacturer with a tube heater. It is now included with the Burner Kit.

<u>CAPACITY</u>	<u>AVAILABLE TUBE LENGTHS</u>	<u>FUEL</u>	<u>INCLUDES</u>	<u>PART #</u>		<u>LIST PRICE</u>
45,000	10', 20'	N.G.	1/2" X 36"	JS-R045-AN	\$	908.00
60,000	20', 30'	N.G.	1/2" X 36"	JS-R060-AN		908.00

The following items are packed inside the burner assembly carton: Stainless Steel Flexible Gas Connector, Burner fastening nuts & bolts, fresh air intake cap, 24V thermostat with 20 ft of 18/2 wire, installation manual.

LPG FIELD CONVERSION KITS FOR STR-JZ BURNERS

Conversion Kits for LP to NG are listed on page P-33

<u>INPUT</u>		<u>PART #</u>		<u>LIST PRICE*</u>
45,000 Btuh	Field Conversion Kit NG to LP	JS-0556-XC	\$	46.40
60,000 Btuh	Field Conversion Kit NG to LP	JS-0557-XX		24.80

TUBE KITS - STR-JZ

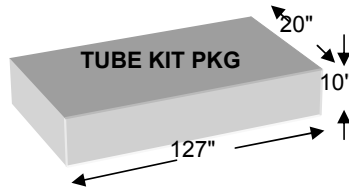

Tube kits include '-JZ' 116" reflectors, webbed hangers, end plate hangers, couplers, and tubes as listed below:

<u>Stand-Alone</u>	<u>Description</u> (includes Reflectors, Hangers, and Couplers)	<u>PART #</u>	<u>LIST PRICE</u>
10' : 45,000 Btuh	Flanged/swaged aluminized tube with no ports, one 5 ft turbulator	TS-4510-JZ \$	442.00
20' : 45,000/60,000	Flanged/swaged aluminized tube with no ports, one emissive coated steel swaged tube, one 4 ft turbulator and one 10 ft turbulator	TS-1420-JZ	566.00
30' : 60,000	Flanged/swaged aluminized tube with no ports, two emissive coated steel swaged tubes, one 4 ft turbulator and one 10 ft turbulator	TS-1430-JZ	762.00



OPTIONAL ACCESSORIES

STR-JZ Series

#8 Hanging Chain - (box of 50' Jack Chain - 'S' hooks separate - see next item)	JL-0798-JC	\$	60.00
'S' Hooks - 1 1/8" - Package of 25	JL-0798-SH		23.20
INSTALLER CONVENIENCE KIT* <i>(* Kit includes: 4" x 10' aluminum flexible duct, 4" wall flue terminal and 10' jack chain)</i>	JS-0598-XX		101.00
4" Horizontal Wall Flue Terminal	JA-0528-XX		39.50
4" Roof Vent Cap	JA-0530-XX		48.00



IMPORTANT: TUBE HEATER GAS CONNECTION EFFECTIVE IMMEDIATELY

ANSI Z83.20-2008 / CSA 2.34-2008

New Standard for Gas-Fired Low-Intensity Infrared Tube Heaters

requires the mandatory supply of specific gas connector by the manufacturer:

Refer to table below for gas connection that *must be shipped with the heater.*

USA : A Stainless Steel Flexible Gas Connector MUST BE SUPPLIED with Tube Heater:

Note: Minimum length of flexible gas connector is 24 inches.

Refer to table below for correct sized connector that is supplied and must be installed.

Gas connector will be shipped in the Burner Kit carton

Mandatory Type '1' Hose Gas Connector	
Input Btuh	Required ID x Length
45,000	1/2" x 24"
60,000	1/2" x 24"

Flexible Gas Connector:

- Replacement Part

S/S Flexible Gas Connector 1/2" x 24"

- for 45,000 up to 130,000 Btuh JL-0771-XX \$ 33.00

Decorative 'Tuxedo' Grille Kit - Matte Black finish

Decorative 'Tuxedo' Grille Kit - Matte Black Grille - 10 foot section	TG-0010-KT	\$	360.00
---	------------	----	--------

Matte black grille & aluminized steel framing dress up a tube heater installation - secures with tabs to 'JZ' Series heater

STR-JZ Elbow Kits:

ST-JZ 90° Aluminized Steel Elbow & Reflector Cover Kit**: <i>(Elbow can be installed right or left hand - includes coupler, reflector cover, end plate/hanger)</i>	JS-0508-JZ	\$	160.00
ST-JZ 180° Elbow & Reflector Kit: ORDER: TWO x JS-0508-JZ 90° ELBOW KITS	Qty 2 x JS-0508-JZ		320.00
Side Reflector 10" deep x 116" long	JS-0509-KT	\$	47.00

STR-JZ COMPLETE SYSTEMS: page T-35
STR-JZ BURNER & TUBE KITS: previous page



PATIO HEATER SELECTION GUIDELINES

Patio layouts and conditions differ widely and usually require a unique heating solution for each patio. Below are some guidelines to assist in the selection of heaters for your patio project. Schwank offers design services for patio projects. Copy, complete and submit the form at the back of this price list.

General

- ☼ Gas fired infrared radiant heat is ideal for "spot comfort" applications like patios, waiting lines, and smoking areas.
- ☼ Besides temperature, wind-chill is the greatest opponent to comfort - any wind break will improve outdoor comfort.
- ☼ Heating customers from at least two sides is much more effective than heating from only one side.
- ☼ If a project faces budget constraints, it is most effective to heat only a portion of a patio. Spreading too few heaters over a larger area will not satisfy customers nor the owner.
- ☼ An investment in patio heating results in additional comfortable seating more cost-effectively than any other renovation.
- ☼ 24 volt control patio heater models can be centrally operated from a patio panel, or by remote control.

2300 Series Luminous Heaters

- 25,000, 35,000, and 50,000 Btuh Natural Gas or Propane Gas
- 24V electrical supply & ignition - central or remote control
- Best suited to 'open' patios
- All models have a black emissive coated stainless steel lens - improves performance and helps heater "disappear"
- For use in salt-air coastal regions an all-stainless-steel-construction model is available

3000 Series Tube Heaters - SPW-JZ & STW-JZ

- 45,000 to 155,000 Btuh, 10 ft to 40 ft tube length
- 120V required for burner, but has 24V ignition for central or remote control
- Best suited for covered or enclosed areas - Tube can be direct vented to beyond the area being heated

- SPW-JZ** - Powder coated burner cabinet for standard covered or enclosed patio application
- STW-JZ** - Stainless steel burner cabinet for harsh or salt-air environments

4000-CB Series Parasol Heaters

- Traditional 'Parasol' (or 'Mushroom') appearance - aesthetic appeal
- Portable & fixed mount (post) styles available in propane or natural gas (except 4003)
- 38,000 Btuh natural gas or propane gas (20 or 30 lb cylinder - 4003: 20 lb only)
- Finishes: Stainless steel, or black 'hammered' texture powder coat
- Best for areas where temporary installation / portability is a must

IEP Series Electric Short-Wave IR

- Instant comfort with the flip of a switch
- Enclosed or covered patios
- 'Tight' spots
- Where long gas pipes runs are impractical

	Luminous		Tube Heaters		Parasol: Portable & Fixed Mount				Electric
	2300	2300 SS	SPW-JZ	STW-JZ	4005-CB	4002-CB	4SN/L5	4BN/L6	IEP
Open Patio Area	✓	✓			✓	✓	✓	✓	
Canopy / Roof Over			✓	✓					✓
Enclosed Area			✓	✓					✓
Coastal Salt-Air Location		✓		✓	✓		✓		
'City Property' Patio					✓	✓			
Portable					✓	✓			
Perimeter Mount	✓	✓	✓	✓					✓
Floor Area Mount	✓	✓					✓	✓	
Central Panel Control	✓	✓	✓	✓					✓
Remote Control	✓	✓	✓	✓					
Propane or Natural Gas	✓	✓	✓	✓	LP Only	LP Only	✓	✓	



Remote Control of patioSchwank Systems

Remote Control Options - Hand Set & Receiver:

- Four "ON/OFF" programmable buttons -> control any number of individual heaters or selected zones independently

OPTIONS: **ORDER ITEMS SEPARATELY**

- 1) Remote Control Receiver Kit field install in burner:
 - Order one per heater
 - Includes receiver, wires, instructions



JP-1234-RK \$ 75.00

- 2) Hand Set Control (four On/Off buttons) *each*
 - Regardless of the number of heaters, Schwank strongly recommends ordering two hand-sets per patio site so that one back-up hand-set is always available
 - Each of four pair of On/Off buttons on the hand set can be programmed to control from one heater to any number of heaters in a zone



JP-1234-HS 45.40

ThermoControl Plus ~ IR heating system management - see next page

patioPANEL ~ Central Control of patioSchwank Systems

Single heater per each patioPanel switch is recommended for best comfort control; at most two 2300 heaters per switch, only one tube heater per switch

- Panel switches have 24 volt capacity

24 Volt TRANSFORMER NOT INCLUDED - SEE NEXT PAGE for SIZES & PRICING.

MODEL	HEATERS	PART #	LIST PRICE
PCP-4	Up To 4	JM-0204-NT	\$263.00
PCP-8	Up To 8	JM-0208-NT	330.00
PCP-12	Up To 12	JM-0212-NT	382.00



24 VOLT CONTROL GUIDELINES

patio Schwank 2300 & sportSchwank ~ Luminous Heaters

- Size 24V transformer 40VA for 1st heater + 20 VA for each additional heater
- patioPanel switches are 24 Volt capacity
- patioPanel: Size transformer for ALL heaters controlled by each individual panel
- for best comfort control, assign one heater to each patioPanel switch
- At most two 2300 heaters can be assigned to each patioPanel switch
- Remote Control: Size transformer(s) for ALL heaters installed on the patio
- ThermoControl Plus is recommended for control of sportSchwank systems

patio Schwank 3000 ~ Tube Heaters

- 120 V supply is ALWAYS required to the burner to power the blower and the individual transformer in each burner assembly
- patioPanel: 24V power to the panel switch is supplied from the transformer within the burner
 ONLY ONE tube heater can be controlled by each patioPanel switch
- Remote Control: Burner is ready for installation of Remote Control Receiver Kit: JP-1234-RK
- Existing tube heaters in the field may still require the installation of optional JS-0568-KT 24V Relay Kit to allow 24 volt control (patioPanel, Remote Control, 24V Thermostat)

ThermoControl Plus



Schwank
INNOVATIVE HEATING SOLUTIONS

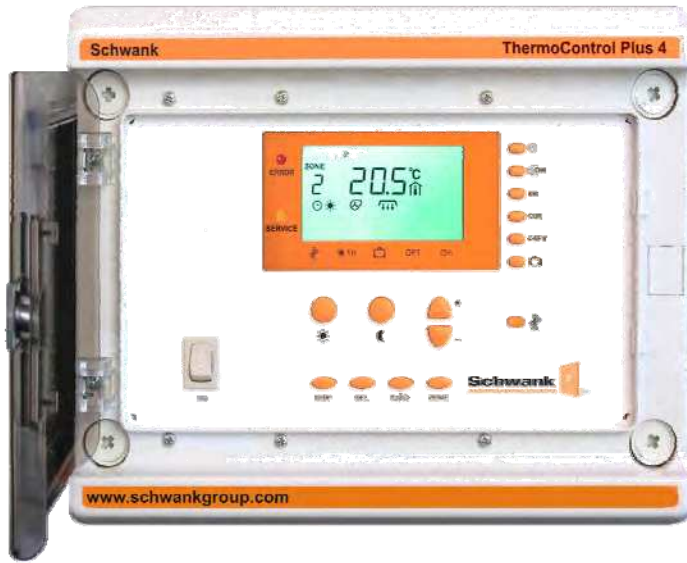

Comfort control & economy of operation for outdoor IR heating

- IR sensor can be installed indoors or outdoors
- Heat control based on comfort temperature
- NEMA 13 enclosure
- Locking cover
- Easy set up and configuration



IR Sensor
Order separately

THERMOCONTROL PLUS 1 - 1 to 2 ZONE		JM-0504-TK-1
- Control: One or two Single-Stage Zones; or one Two-Stage Zone		
Includes	ThermoControl Outdoor Air Temperature Sensor	Qty 1
	24V Transformer 100VA* (24Vac powers control & relays)	1
	24V External Relay switches power to zone transformer	2

THERMOCONTROL PLUS 2 - 1 TO 4 ZONE		JM-0504-TK-2
- Control: up to four Single-Stage Zones, or two Two-Stage Zone		
Includes	ThermoControl Outdoor Air Temperature Sensor	Qty 1
	24V Transformer 100VA* (24Vac powers control & relays)	1
	24V External Relay switches power to zone transformer	4

THERMOCONTROL PLUS 4 - 1 TO 8 ZONE		JM-0504-TK-4
- Control: up to eight Single-Stage Zones, or four Two-Stage Zone		
Includes	ThermoControl Outdoor Air Temperature Sensor	Qty 1
	24V Transformer 100VA* (24Vac powers control & relays)	1
	24V External Relay switches power to zone transformer	8

Refer to chart and
guidelines next page:
Zone Schemes and
Component Quantity

**Call your local
Schwank
representative
for project
design and
pricing of the
ThermoControl
Plus**

* The supplied 24Vac 100VA transformer powers the control panel, and external relays at each heater zone.
Order a separate 24Vac transformer for each heater zone to power heaters - see page 17.

IR Sensor Required : ThermoControl RADIANT SENSOR **JM-0505-XX**
- Minimum one required per zone, or for 'temperature averaging' four required per zone

more information next page ...

.... continued

ThermoControl Plus



IR Sensor

- IR sensor senses and averages radiant and ambient temperatures for true comfort control
- Indoor or outdoor installation
- Use one IR sensor per zone, or use four to get temperature averaging

Zone Schemes and Component Quantity

CONTROLLER	ORDER PART #	Zone Control Combinations		Total Number of Zones	ALSO ORDER:		
		Single Stage	Two Stage*		RADIANT SENSORS 0505-XX		Optional Setback Override JM-0507-XX
					Minimum 1 per Zone	OR Temperature Averaging	
ThermoControl Plus 1	JM-0504-TK-1	2	-	2	2	8	2
		1	-	1	1	4	1
		1	1	2	2	8	2
ThermoControl Plus 2	JM-0504-TK-2	4	-	4	4	16	4
		3	-	3	3	12	3
		2	1	3	3	12	3
		1	1	2	2	8	2
ThermoControl Plus 4	JM-0504-TK-4	8	-	8	8	32	8
		7	-	7	7	28	7
		6	-	6	6	24	6
		6	1	7	7	28	7
		5	-	5	5	20	5
		5	1	6	6	24	6
		4	2	6	6	24	6
		2	3	5	5	20	5
		1	3	4	4	16	4
-	4	4	4	16	4		



* Two-Stage Zone: Control either two-stage heaters OR single-input heaters: 50% or more in Stage 1, balance in Stage 2

Guidelines - Typical Zone Scheme:

1. ThermoControl Plus controllers have 24Vac 'wet' contacts. Call for heat activates 24Vac to external power relays
2. A sufficient quantity of External Power Relays are supplied with the ThermoControl Plus to switch 120Vac to a 120/24Vac transformer in each of the heater zones
3. Zone Sizes: Luminous heaters - Up to 12 heaters per zone

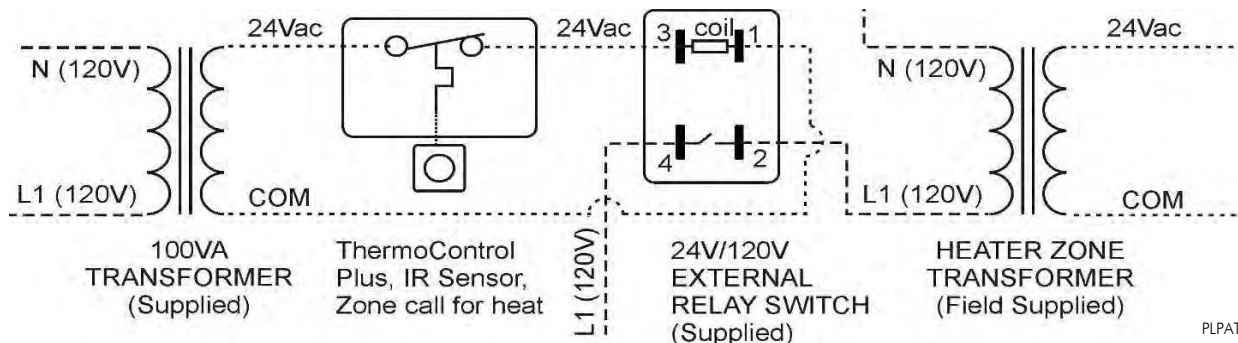



ZONE TRANSFORMERS 24Vac

for sportSchwank & 2300 Series

Each zone transformer is sized to suit the total number of heaters being controlled in the zone - see below for sizing guide.

Remote control of 2300 Series heaters requires a 24 volt transformer(s) sized to suit the total number of heaters installed - see below for sizing guide.

Refer to page 14 for guidelines on 24 Volt control of patioSchwank heating systems

24V TRANSFORMER SIZING GUIDE: sportSchwank & patioSchwank 2300 Series heaters

- On a single heater use one 40 VA transformer.
- On a zone with multiple heaters, use a transformer sized at 40 VA per first heater and 20 VA per each additional heater.

24V TRANSFORMERS

<u>SIZE</u>		<u>PART #</u>	<u>LIST PRICE</u>
40 VA Transformer	4"x 4" Electrical Box Mount	JL-0776-XX	\$ 70.00
100 VA Transformer	Closed Type	JL-0778-XX	131.00
150 VA Transformer	Closed Type	JL-0779-XX	157.00
200 VA Transformer	Closed Type	JL-0780-XX	180.00
250 VA Transformer	Closed Type	JL-0781-XX	197.00
350 VA Transformer	Closed Type	JL-0781-AA	230.00

See INSTALLATION MANUAL to determine gauge of distribution wire. (minimum 16 gauge).



sportSchwank



Outdoor Venue Comfort

- **Stadiums, Outdoor concerts**
- **Fuel cost less than 5 cents per fan per game**
- **Effective from as high as 180 feet**
- **15° to 20°F comfort rise**

<u>MODEL</u>	<u>CAPACITY</u>	<u>I.R. OUTPUT</u>	<u>GAS</u>	<u>PART #</u>
sportSchwank 10 N/L	37,500 Btuh	24,600	NG	SP-S010-NG
			LP	SP-S010-LP
sportSchwank 15 N/L	56,000 Btuh	35,400	NG	SP-S015-NG
			LP	SP-S015-LP
sportSchwank 20 N/L	75,000 Btuh	49,100	NG	SP-S020-NG
			LP	SP-S020-LP
sportSchwank 30 N/L	103,000 Btuh	69,700	NG	SP-S030-NG
			LP	SP-S030-LP

Please contact your local Schwank Representative or Customer Service for Project Design and Pricing

All sportSchwank heaters require 24 volt connection

OPTIONAL ACCESSORIES FOR sportSchwank

	<u>PART #</u>	<u>LIST PRICE</u>
Flexible Gas Connector 1/2" x 18"	JL-0771-FF	\$ 24.90
Flexible Gas Connector 1/2" x 24"	JL-0771-XX	32.00
#2 Lion Chain, roll 200'	JL-0800-XX	94.00
Safety Snap Hooks 2" - Package of 24	JL-0800-SH	39.00
Safety Snap Hooks 2" - Package of 100	JL-0800-SH-B	119.00
Transformers	See previous page	

ThermoControl Plus see complete info Page 15

- IR Heating Management System
- Senses ambient & radiant temperatures
- Single- or Two-Stage zone control

	<u>Zones</u>	
ThermoControl Plus 1:	1 or 2	JM-0504-TK1
ThermoControl Plus 2:	2 to 4	JM-0504-TK2
ThermoControl Plus 4:	4 to 8	JM-0504-TK4



°F & °C scales



IR Sensor
Order separately

IR Sensor Required : ThermoControl RADIANT SENSOR JM-0505-XX
- Minimum one required per zone, or for 'temperature averaging' four required per zone

Please contact your local Schwank Representative or Customer Service for Project Design and Pricing



Overhead Perimeter Mount System

Black Emissive Coated Stainless Steel Lens on ALL Models

- Helps preserve appearance
- Increases IR output

patioSchwank 2300 SERIES OUTDOOR PATIO HEATERS

Minimum mounting height of 8 ft

24V TRANSFORMER NOT INCLUDED - see page P-19

Remote & patioPanel Controls: page P-17

409 Stainless Steel Lens has Black Emissive Coating

- Aluminized Steel construction of other heater body components - for Standard Application

NOTE: In some environments 409 grade stainless steel lens can experience some surface discoloration. This oxidation does not affect the heater's performance or longevity, but may require occasional touch-up to maintain appearance.

MODEL	INPUT	FINISH - Including Lens Cover	GAS	PART #	LIST PRICE
2312	23,000	BLACK - High Temperature	NG	MO-2312-NG	\$ 1,493.00
			LP	MO-2312-LP	1,493.00
2313	35,000	BLACK - High Temperature	NG	MO-2313-NG	1,709.00
			LP	MO-2313-LP	1,709.00
2315	50,000	BLACK - High Temperature	NG	MO-2315-NG	1,761.00
			LP	MO-2315-LP	1,761.00

304 Stainless Steel Lens has Black Emissive Coating

- All Stainless Steel Construction - BEST for Salt-Air Coastal Regions

NOTE: 304 grade stainless steel lens does not oxidize even in harsh environments - lens is black emissive coated.

MODEL	INPUT	FINISH - Including Lens Cover	GAS	PART #	LIST PRICE
2312 S/S	23,000	BLACK - High Temperature	NG	MO-2312-SN	Call for current pricing
			LP	MO-2312-SL	
2313 S/S	35,000	BLACK - High Temperature	NG	MO-2313-SN	1-877-446-3727
			LP	MO-2313-SL	
2315 S/S	50,000	BLACK - High Temperature	NG	MO-2315-SN	1-877-446-3727
			LP	MO-2315-SL	

2300 Series MOUNTING OPTIONS

	PART #	LIST PRICE
 <p>2300 Series Wall Mounting Bracket</p>	JP-2300-MB	\$ 149.00
 <p>2300 Series 4" Pole Mounting Assembly: <i>Pole Clamp + Heater Bracket</i></p>	JP-2300-PK	139.00
 <p>2300 Series Wall/Ceiling Mounting Arm Kit <i>(Prepiped & wired)</i></p>	JP-2300-MK	453.00
 <p>Flexible Gas Connector 1/2" x 24"</p>	JL-0771-XX	33.00

Remote & patioPanel Controls ~ See page P-14 for information, sizes & pricing ~

**Model SPW-JZ with
Powder Coated Cabinet.
Economical heating
for covered or enclosed
patios!**

Schwank
INNOVATIVE HEATING SOLUTIONS



*SPW-JZ shown with optional
Tuxedo Grille
Details below*

patioSchwank 3000 Model SPW-JZ OUTDOOR PATIO HEATER

KIT ASSEMBLY CHART: next page
SPW-JZ BURNER KI TS: page P-19
SPW-JZ TUBE KI TS: page P-20
ACCESSORI ES: page P-25

DESIGNED & BUILT FOR COVERED OR ENCLOSED PATIOS AND DAMP ENVIRONMENTS

ALL ALUMINIZED STEEL TUBE(S) AND ALUMINIZED STEEL DEEP FOCUS SHIELD REFLECTORS.

PRICES INCLUDE BURNER ASSEMBLY WITH POWDER COATED STEEL CABINET AND FOLLOWING COMPONENTS: STAINLESS STEEL FLEX GAS CONNECTOR, MOISTURE RESISTANT DIRECT SPARK IGNITION SYSTEM, FRESH AIR INTAKE COLLAR, 24/120V RELAY SWITCH, COUPLING KIT(S), TURBULATOR(S), REFLECTOR END PLATE HANGERS, WEBBED HANGERS, ALL ALUMINIZED STEEL TUBE(S) AND ALUMINIZED STEEL DEEP FOCUS SHIELD REFLECTORS.

COMPLETE SYSTEMS:

<u>MODEL</u>	<u>Fuel</u>	<u>CAPACITY</u>	<u>AVAILABLE TUBE</u>		<u>LIST PRICE</u>
			<u>LENGTH</u>		
SPW-JZ 45	NG	45,000 Btuh	10'	\$	1,648.00
SPW-JZ 60	NG	60,000 Btuh	20'		1,813.00
			30'		2,006.00
SPW-JZ 80	NG	80,000 Btuh	20'		1,813.00
			30'		2,006.00
SPW-JZ 110	NG	110,000 Btuh	30'		2,006.00
			40'		2,229.00
SPW-JZ 130	NG	130,000 Btuh	30'		2,006.00
			40'		2,229.00
SPW-JZ 155**	NG	155,000 Btuh	40'		2,298.00

NOTES: Standard burners are stocked for natural gas only. Field conversion kits are required for conversion to LP Gas - refer to 'Burner Kits' page.

For outdoor applications, Schwank does not recommend tube length/firing rate combinations other than indicated above - for extraordinary projects, contact Schwank

** With a relatively high firing rate, the SPW-JZ 155 can be used for outdoor applications with mounting heights of 14 to 18 ft

Decorative 'Tuxedo' Grille Kit - Matte Black finish

Decorative 'Tuxedo' Grille Kit - Matte Black Grille - 10 foot kit section TG-0010-KT \$ 360.00

Matte black grille & aluminized steel framing dress up a tube heater installation - secures with tabs to 'JZ' Series heater

Remote & patioPanel Control of patioSchwank 3000 SPW-JZ

~ See page P-14 for information, sizes & pricing ~



'SPW-JZ' Series

 A flexible gas connector is now required to be supplied by the manufacturer with a tube heater. It is now included with the Burner Kit.

SPW-JZ: BURNER & '-JZ' TUBE KIT ASSEMBLY CHART for patioSchwank 3000 SERIES

SPW-JZ: POWDER COATED BURNER CABINET + ALUMINIZED STEEL REFLECTORS & TUBES

SPW-JZ TUBE KIT PART # & QUANTITY REQUIRED

MODEL	BURNER KIT (Includes S/S FLEX CONNECTOR) Gross Wt = 30 lbs	Nominal Tube Length (ft)	Stand-Alone Tube Kits			
			70	120	170	210
			10'	20'	30'	40'
			TS- 4510- JZ	TW-1420- JZ	TW-1430- JZ	TW-1040- JZ
SPW-JZ 45	JS-045W-BN	10'	1			
SPW-JZ 60	JS-060W-BN	20'		1		
		30'			1	
SPW-JZ 80	JS-080W-BN	20'		1		
		30'			1	
SPW-JZ 110	JS-110W-BN	30'			1	
		40'				1
SPW-JZ 130	JS-130W-BN	30'			1	
		40'				1
SPW-JZ 155**	JS-155W-BN	40'				1

NOTES: Standard burners are stocked for natural gas only. Field conversion kits are required for conversion to LP Gas - refer to 'Burner Kits' page.

For outdoor applications, Schwank does not recommend tube length/firing rate combinations other than indicated above - for extraordinary projects, contact Schwank

** With a relatively high firing rate, the SPW-JZ 155 can be used for outdoor applications with mounting heights of 14 to 18 ft

SPW-JZ Series Burners require 120V supply - Comes with a 24/120V relay installed for Remote or patioPanel control of heater system
Details on page P-14



A flexible gas connector is now required to be supplied by the manufacturer with a tube heater. It is now included with the Burner Kit.

SPW-JZ BURNER KITS: patioSchwank 3000 Series

POWDER COATED BURNER CABINET mounts to

Aluminized Steel Tubes & Aluminized Steel Reflectors

See 'Tube Kits' next page

<u>BTUH CAPACITY</u>	<u>AVAILABLE TUBE LENGTHS</u>	<u>FUEL</u>	<u>INCLUDES S/S FLEX CONNECTOR</u>	<u>PART #</u>	<u>LIST PRICE*</u>
45,000	10'	N.G.	1/2" X 36"	JS-045W-BN	\$ 1,206.00
60,000	20', 30'	N.G.	1/2" X 36"	JS-060W-BN	1,206.00
80,000	20', 30'	N.G.	1/2" X 36"	JS-080W-BN	1,206.00
110,000	30', 40'	N.G.	1/2" X 36"	JS-110W-BN	1,206.00
130,000	30', 40'	N.G.	1/2" X 36"	JS-130W-BN	1,206.00
155,000	40'	N.G.	3/4" X 36"	JS-155W-BN	1,275.00

All burner assemblies require line voltage (120VAC), but are 24 volt control ready (24/120V relay factory installed).

The following items are packed inside the burner Kit carton: Burner fastening nuts & bolts, ignitor (mounted), installation manual

NOTE: SPW-JZ Series burners require 120V supply - Comes with a 24/120V relay installed for remote or patioPanel control of heater system

LPG FIELD CONVERSION KITS FOR SPW-JZ BURNERS

<u>INPUT</u>	<u>PART #</u>	<u>LIST PRICE*</u>
45,000 Btuh Field Conversion Kit NG to LP	JS-0556-XA	\$ 46.40
60,000 Btuh Field Conversion Kit NG to LP	JS-0557-XX	24.80
80,000 Btuh Field Conversion Kit NG to LP	JS-0559-XX	24.80
110,000 Btuh Field Conversion Kit NG to LP	JS-0561-XX	24.80
130,000 Btuh Field Conversion Kit NG to LP	JS-0563-XX	24.80
155,000 Btuh Field Conversion Kit NG to LP	JS-0565-XX	24.80

Conversion Kits for LP to NG are listed on page P-33

SPW-JZ COMPLETE SYSTEMS are listed on **page P-17**

SPW-JZ BURNER & TUBE KIT ASSEMBLY CHART is on **previous page**

SPW-JZ TUBE KITS are on the **next page**

OPTIONAL ACCESSORIES are on the **page P-25**

'SPW-JZ' & 'STW-JZ'

'-JZ' TUBE KITS (Emissive Coated) for SPW-JZ & STW-JZ OUTDOOR/PATIO TUBE HEATER

ALUMINIZED STEEL REFLECTORS + ALUMINIZED STEEL TUBES

<u>Stand-Alone</u>	Each kit includes 116" reflectors, webbed hanger system, couplers	<u>TUBE KIT #</u>	<u>LIST PRICE*</u>
10' : 45,000	Emissive coated flanged/swaged aluminized tube with no ports and 4 foot rod & plate turbulator	TS-4510-JZ	\$ 442.00
20' : 60,000/80,000	Flanged/swaged tube with no ports, one coated aluminized steel swaged tube, one 4 ft turbulator and one 10 ft turbulator	TW-1420-JZ	607.00
30' : 60/80/110/130	Flanged/swaged tube with no ports, two coated aluminized steel swaged tubes, one 4 ft turbulator and one 10 ft turbulator	TW-1430-JZ	800.00
40' : 80/110/130/155	Flanged/swaged tube with no ports, 3 coated aluminized steel swaged tubes, one 4 ft turbulator and one 10 ft turbulator	TW-1040-JZ	1,023.00

COMPLETE SPW-JZ SYSTEMS are listed on **page P-17**

SPW-JZ BURNER & TUBE KIT ASSEMBLY CHART is on **page P-18**

SPW-JZ BURNER KITS are on the **previous page**

OPTIONAL ACCESSORIES are on **page P-25**



STAINLESS STEEL BURNER CABINET
BEST for Salt-Air Coastal Regions



*STW-JZ shown with optional Tuxedo Grille
See details below*

A flexible gas connector is now required to be supplied by the manufacturer with a tube heater. It is now included with the Burner Kit.

KIT ASSEMBLY CHART: page P-22
STW-JZ BURNER KITS: page P-23
STW-JZ TUBE KITS: page P-24
ACCESSORIES: page P-25

patioSchwank 3000 Model STW-JZ OUTDOOR PATIO HEATER

DESIGNED & BUILT FOR COVERED OR ENCLOSED OUTDOOR PATIOS IN COASTAL REGIONS
STAINLESS STEEL CABINET & ALUMINIZED STEEL TUBE(S) AND DEEP FOCUS SHIELD REFLECTORS.

PRICES INCLUDE BURNER ASSEMBLY WITH STAINLESS STEEL CABINET AND FOLLOWING COMPONENTS: STAINLESS STEEL FLEX GAS CONNECTOR, 4" COMBUSTION AIR INTAKE ADAPTER & 4" WALL HOOD, HANGER/REFLECTOR END PLATES, MOISTURE & ACID RESISTANT DIRECT SPARK IGNITION SYSTEM, 24/120V RELAY SWITCH, COUPLING KIT(S), TURBULATOR(S), WEBBED HANGERS, ALL ALUMINIZED STEEL TUBE(S) AND ALUMINIZED STEEL DEEP FOCUS SHIELD REFLECTORS.

COMPLETE SYSTEMS:

<u>MODEL</u>	<u>Fuel</u>	<u>CAPACITY</u>	<u>AVAILABLE TUBE</u>		<u>LIST PRICE</u>
			<u>LENGTH</u>		
STW-JZ 45	NG	45,000 Btuh	10'	\$	2,128.00
STW-JZ 60	NG	60,000 Btuh	20'		2,293.00
			30'		2,486.00
STW-JZ 80	NG	80,000 Btuh	20'		2,293.00
			30'		2,486.00
STW-JZ 110	NG	110,000 Btuh	30'		2,486.00
			40'		2,709.00
STW-JZ 130	NG	130,000 Btuh	30'		2,486.00
			40'		2,709.00
STW-JZ 155**	NG	155,000 Btuh	40'		2,778.00

NOTES: Standard burners are stocked for natural gas only. Field conversion kits are required for conversion to LP Gas - refer to 'Burner Kits' page.

This burner draws combustion air through a 4" diameter collar on the cabinet.
Use the STW-JZ if outside combustion air is required.

For outdoor applications, Schwank does not recommend tube length/firing rate combinations other than indicated above
- For extraordinary projects, contact Schwank

** With a relatively high firing rate, the STW-JZ 155 can be used for outdoor applications with mounting heights of 14 to 18 ft

Decorative 'Tuxedo' Grille Kit - Matte Black finish

Decorative 'Tuxedo' Grille Kit - Matte Black Grille - 10 foot kit section TG-0010-KT \$ 360.00
Matte black grille & aluminized steel framing dress up a tube heater installation - secures with tabs to 'JZ' Series heater

Remote & patioPanel Control of patioSchwank 3000 STW-JZ

~ See page P-14 for information, sizes & pricing ~



'STW-JZ' Series

 A flexible gas connector is now required to be supplied by the manufacturer with a tube heater. It is now included with the Burner Kit.

STW-JZ: BURNER & 'JZ' TUBE KIT ASSEMBLY CHART

STW-JZ: STAINLESS STEEL BURNER CABINET + ALUMINIZED STEEL REFLECTORS & TUBES

STW-JZ TUBE KIT PART # & QUANTITY REQUIRED

MODEL	BURNER KIT (Includes S/S FLEX CONNECTOR) Gross Wt = 30 lbs	Tube Kit Gross Weight (lbs) Nominal Tube Length (ft)	Stand-Alone Tube Kits			
			70	120	170	210
			10'	20'	30'	40'
			TS- 4510- JZ	TW-1420- JZ	TW-1430- JZ	TW-1040- JZ
STW-JZ 45	JS-045P-BN	10'	1			
STW-JZ 60	JS-060P-BN	20'		1		
		30'			1	
STW-JZ 80	JS-080P-BN	20'		1		
		30'			1	
STW-JZ 110	JS-110P-BN	30'			1	
		40'				1
STW-JZ 130	JS-130P-BN	30'			1	
		40'				1
STW-JZ 155	JS-155P-BN	40'				1

**NOTE: STW-JZ Series burners require 120V supply - Comes with a 24/120V relay installed for remote or patioPanel control of heater system
Details on page P-14 & 15**



STW-JZ BURNER KITS for patio applications

STAINLESS STEEL BURNER CABINET FOR HARSH ENVIRONMENTS, COASTAL REGIONS



A flexible gas connector is now required to be supplied by the manufacturer with a tube heater. It is now included with the Burner Kit.

STW-JZ uses Aluminized Steel Tubes & Aluminized Steel Reflectors

<u>BTUH CAPACITY</u>	<u>AVAILABLE TUBE LENGTHS</u>	<u>FUEL</u>	<u>INCLUDES S/S FLEX CONNECTOR</u>	<u>PART #</u>	<u>LIST PRICE*</u>
45,000	10'	N.G.	1/2" X 36"	JS-045P-BN	\$ 1,686.00
60,000	20', 30'	N.G.	1/2" X 36"	JS-060P-BN	1,686.00
80,000	20', 30'	N.G.	1/2" X 36"	JS-080P-BN	1,686.00
110,000	30', 40'	N.G.	1/2" X 36"	JS-110P-BN	1,686.00
130,000	30', 40'	N.G.	1/2" X 36"	JS-130P-BN	1,686.00
155,000	40'	N.G.	3/4" X 36"	JS-155P-BN	1,755.00

The following items are packed inside the burner kit carton: Burner fastening nuts & bolts, S/S Flexible Gas Connector, ignitor (mounted), installation manual, fresh air intake cap.

All burner assemblies operate on line voltage (120VAC).

* Burner & Tube Kit prices represent the component prices in conjunction with purchasing a complete system.

NOTE: STW-JZ Series Burners require 120V supply - Comes with a 24/120V Relay installed for Remote or patioPanel control of Heater System

Heaters are shipped and invoiced as 'Burner Kit' and 'Tube Kits'

LPG FIELD CONVERSION KITS FOR STW-JZ BURNERS

<u>INPUT</u>	<u>PART #</u>	<u>LIST PRICE*</u>
45,000 Btuh Field Conversion Kit NG to LP	JS-0556-XA	\$ 46.40
60,000 Btuh Field Conversion Kit NG to LP	JS-0557-XX	24.80
80,000 Btuh Field Conversion Kit NG to LP	JS-0559-XX	24.80
110,000 Btuh Field Conversion Kit NG to LP	JS-0561-XX	24.80
130,000 Btuh Field Conversion Kit NG to LP	JS-0563-XX	24.80
155,000 Btuh Field Conversion Kit NG to LP	JS-0565-XX	24.80

Conversion Kits for LP to NG are listed on page P-33

STW-JZ COMPLETE SYSTEMS are listed on **page P-21**

STW-JZ BURNER & TUBE KIT ASSEMBLY CHART is on **page P-22**

STW-JZ TUBE KITS are listed on **page P-24**

OPTIONAL ACCESSORIES are on the **page P-25**

'STW-JZ' & 'SPW-JZ'

'-JZ' TUBE KITS (*Emissive Coated*) for STW-JZ & SPW-JZ OUTDOOR/PATIO TUBE HEATER

ALUMINIZED STEEL REFLECTORS + ALUMINIZED STEEL TUBES

<u>Stand-Alone</u>	Each kit includes 116" reflectors, webbed hanger system, couplers	<u>TUBE KIT #</u>	<u>LIST PRICE*</u>
10' : 45,000	Emissive coated Flanged/swaged aluminized tube with no ports and 4 foot rod & plate turbulator	TS-4510-JZ	\$ 442.00
20' : 60,000/80,000	Flanged/swaged tube with no ports, one coated aluminized steel swaged tube, one 4 ft turbulator and one 10 ft turbulator	TW-1420-JZ	607.00
30' : 60/80/110/130	Flanged/swaged tube with no ports, two coated aluminized steel swaged tubes, one 4 ft turbulator and one 10 ft turbulator	TW-1430-JZ	800.00
40' : 80/110/130/155	Flanged/swaged tube with no ports, 3 coated aluminized steel swaged tubes, one 4 ft turbulator and one 10 ft turbulator	TW-1040-JZ	1,023.00

STW-JZ COMPLETE SYSTEMS are listed on **page P-21**

STW-JZ Burner & Tube Kit Assembly Chart is on **page P-22**

STW-JZ BURNER KITS are on the **previous page**

OPTIONAL ACCESSORIES are on the **next page**

OPTIONAL ACCESSORIES
3000 SERIES PATIO HEATERS
SPW-JZ & STW-JZ Tube Models

Controls:

Remote & Panel Controls; 24 Volt Control Guidelines - see page P-14 & 15

	<u>PART #</u>	<u>LIST PRICE</u>
24V Relay Kit* - field mounted:	JS-0568-KT	\$ 37.40
*Not required for heaters that have 24/120V relay factory mounted (May 1, 2006)		
May be required for 24V control of existing installations ~ contact Schwank with Model & Serial #'s		
Moisture Proof Thermostat (NEMA 4X enclosure)	JS-0570-XX	341.00
Flue Vent Terminals:		
4" wall horizontal	JA-0528-XX	\$ 39.50
6" wall horizontal	JA-0529-XX	48.00
4" roof	JA-0530-XX	48.00
6" roof	JA-0531-XX	56.00
Vent Tee 4" X 4" X 6" (ADD <u>TWO</u> optional tube couplers JA-0516-SW if desired for vent pipe connection to tee)	JA-0514-XX	197.00
4" Swaged Tube Coupler (required quantity is shipped with heater)	JA-0516-SW	41.70
- Also available in stainless steel (custom item ~ longer lead time)	JA-0516-SS	29.90



IMPORTANT: TUBE HEATER GAS CONNECTION
EFFECTIVE JUNE 2009

ANSI Z83.20-2008 / CSA 2.34-2008

New Standard for Gas-Fired Low-Intensity Infrared Tube Heaters

requires the mandatory supply of specific gas connector by the manufacturer:

Refer to table below for gas connection that *must be shipped with the heater.*

USA : A Stainless Steel Flexible Gas Connector MUST BE SUPPLIED with Tube Heater:

Note: Minimum length of flexible gas connector is 24 inches.

Refer to table below for correct sized connector that is supplied and must be installed.

Gas connector will be shipped in the Burner Kit carton

Mandatory S/S Flexible Gas Connector	
Input Btuh	Required ID x Length
45,000	1/2" x 24"
60,000	1/2" x 24"
80,000	1/2" x 24"
100,000	1/2" x 24"
110,000	1/2" x 24"
130,000	1/2" x 24"
155,000	3/4" x 36"

Flexible Gas Connectors:

- Replacement Parts

S/S Flexible Gas Connector 1/2" x 24"		
- for 45,000 up to 130,000 Btuh	JL-0771-XX	\$ 33.00
S/S Flexible Gas Connector 3/4" x 36"		
- for 155,000 to 200,000 Btuh	JL-0771-YY	102.00



Decorative 'Tuxedo' Grille Kit - Matte Black finish

Decorative 'Tuxedo' Grille Kit - Matte Black Grille - 10 foot kit section	TG-0010-KT	\$360.00
<i>Matte black grille & aluminized steel framing dress up a tube heater installation - secures with tabs to 'JZ' Series heater</i>		

Elbow Kits:

90° Aluminized Steel Elbow & Reflector Cap Kit**: <i>(Elbow can be installed right or left hand - Includes coupler, reflector cap, hanger plate)</i>	JS-0508-JZ	160.00
180° Elbow Kit* = Combine TWO JS-0508-JZ 90° Kits	Qty 2 x JS-0508-JZ	320.00

Hanging Chain:

#2 Lion Chain - **115 lb work load** - 200 ft roll



<u>PART #</u>	<u>LIST PRICE</u>
JL-0800-XX	\$ 97.00

#8 Jack Chain - **60 lb work load** - 50 ft box



JL-0798-JC	60.00
------------	-------

Quantity of Chain required: $\left\{ \begin{array}{l} \text{S100, SET Series heater} = ((\text{heater tube length}/10) \times 2) + 1 \times \text{length of chain at each suspension point} \\ \text{ie: S100 40 ft heater 3 ft below structural support} = ((40/10) \times 2) + 1 \times 3 = 27 \text{ ft of chain} \end{array} \right.$

Safety Snap Hooks - 2"



Package of 24	JL-0800-SH	40.20
Package of 100	JL-0800-SH-B	123.00

'S' Hooks - 1 7/8" - Package of 25

JL-0798-SH	23.20
------------	-------

Quantity of 'Snap' or 'S' Hooks: $\text{S100, SET Series quantity required} = ((\text{tube length}/10) \times 4) + 2$: ie: SET x 40 ft = $(40/10) \times 4 + 2 = 18$ hooks

Side Reflector 10" deep x 116" long	JS-0509-KT	47.00
Tube Protection Screen - 5 ft length	JA-0780-XX	60.00



**4000 SERIES
PORTABLE PARASOL
FOR OUTDOOR PATIOS**

**4002-CB & 4005-CB
Premier Commercial
Portable Models**

38,000 Btuh Conical Burner
Improved radiant heat comfort
16% LESS FUEL USE than 45,000 Btuh heaters.
- Tank lasts longer
- Labor saved with fewer tank changes



<u>MODEL</u>	<u>FINISH</u>	<u>Gas Type</u>	<u>INPUT</u>	<u>ORDER PART #</u>	<u>LIST PRICE</u>
4005-CB*	Stainless Steel	LP Gas	38,000 Btuh	PS-4005-CB	\$ 720.00
4002-CB*	Hammered Black	LP Gas	38,000 Btuh	PS-4002-CB	597.00

*Inner & outer emitters in conical burner increase and direct radiant heat output;
Single piece 32" reflector;
Battery electronic ignitor;
4" diameter wheels for portability;
Housing for 20 or 30 lbs tank (L.P. tank not included).
Three year commercial use warranty on burner
Currently available in propane only.*

* Ships in two separate cartons: 1: Burner, post, tank cover, base + 2: Reflector

32" Single Piece Reflector	JP-4070-CB	93.00
----------------------------	------------	-------

BURNER HEAD KITS

Use this kit for field replacement of old deteriorated burner heads

Burner head, and 1 piece 32" reflector included,
plus battery spark ignition, and the appropriate hose:

LP: 52 inch hose with regulator & connector for LP Cylinder
NG: 3/8" x 94" hose with 3/8" MPT



Note: Burner head mounts to a 2.5" I.D. post - adaptation to fit a different diameter post is the responsibility of the installer.

LP Gas	46,000	JP-401L-KL	#N/A
Nat. Gas	45,000	JP-401L-KN	#N/A



NEW
Now available with
24 Volt Ignition
~ see next page ~

**4000 SERIES
FIXED MOUNT PARASOL
FOR OUTDOOR PATIOS**

**4SN5-CB, 4SL5-CB
4BN6-CB, 4BL6-CB**

**Premier Commercial
Permanent Mount Models**

*38,000 Btuh Conical Burner
Improved radiant heat comfort*

16% LESS FUEL USE than 45,000 Btuh heaters.



4SN/L5-CB
Stainless Steel
N or L
indicates gas type

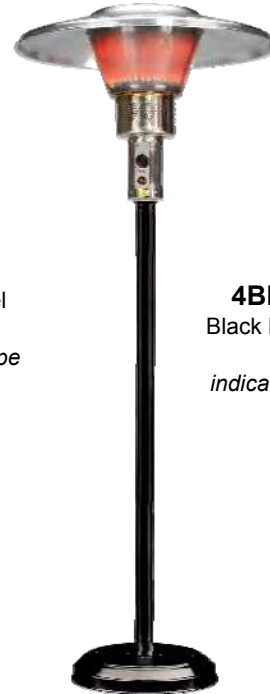

4BN/L6-CB
Black Powder Coat
N or L
indicates gas type

4SN/L5-CB* Stainless Steel Finish - Order Heater as three component parts

	<u>HEATER COMPONENT</u>	<u>FUEL TYPE</u>	<u>INPUT</u>	<u>ORDER PART #</u>	<u>LIST PRICE</u>
1	Burner Head & Heater Base	Nat. Gas	38,000 Btuh	<i>Either</i> JP-4SN5-CB	\$ 617.00
		Propane	38,000 Btuh	<i>or</i> JP-4SL5-CB	617.00
2	One Piece Post - Stainless Steel			<i>Plus</i> JP-4PST-SS	155.00
3	32" Single Piece Reflector			<i>Plus</i> JP-4070-CB	93.00
Total List Price Stainless Steel					\$ 865.00

4BN/L6-CB* Hammered Black Powder Coat Finish - Order Heater as three component parts

	<u>HEATER COMPONENT</u>	<u>FUEL TYPE</u>	<u>INPUT</u>	<u>ORDER PART #</u>	<u>LIST PRICE</u>
1	Burner Head & Heater Base	Nat. Gas	38,000 Btuh	<i>Either</i> JP-4BN6-CB	\$ 576.00
		Propane	38,000 Btuh	<i>or</i> JP-4BL6-CB	576.00
2	One Piece Post - Hammered Black Finish			<i>Plus</i> JP-4PST-BK	110.00
3	32" Single Piece Reflector			<i>Plus</i> JP-4070-CB	93.00
Total List Price Hammered Black Finish					\$ 779.00

NOTE: No gas regulator is supplied with heater. Gas pressure to be regulated at gas supply by installer. Refer to installation manual for details.

* Ships in three separate cartons: 1: Burner Head & Heater Base + 2: One Piece Post + 3: Reflector



**4000 SERIES
24 VOLT FIXED MOUNT
FOR OUTDOOR PATIOS**

*24 Volt gas valve and ignition
for central or local control*

**4SN5-CB-24, 4SL5-CB-24
4BN6-CB-24, 4BL6-CB-24**

**Premier Commercial
Permanent Mount Models**

*38,000 Btuh Conical Burner
Improved radiant heat comfort
16% LESS FUEL USE than 45,000 Btuh heaters.*



**4SN5-CB-24
4SL5-CB-24**

Stainless Steel
N or L
indicates gas type



**4BN6-CB-24
4BL6-CB-24**

Hammered Black
Powder Coat
N or L
indicates gas type

4SN/L5-CB-24* Stainless Steel Finish - Order Heater as three component parts

	<u>HEATER COMPONENT</u>	<u>FUEL TYPE</u>	<u>INPUT</u>	<u>ORDER PART #</u>	<u>LIST PRICE</u>
1	Burner Head & S/S Heater Base	Nat. Gas	38,000 Btuh	Either JP-4SN5-CB-24 \$	999.00
		Propane	38,000 Btuh	or JP-4SL5-CB-24	999.00
2	One Piece Post - Stainless Steel			Plus JP-4PST-SS	150.00
3	32" Single Piece Reflector			Plus JP-4070-CB	90.00
Total List Price Stainless Steel \$					1,239.00

4BN/L6-CB-24* Hammered Black Powder Coat Finish - Order Heater as three component parts

	<u>HEATER COMPONENT</u>	<u>FUEL TYPE</u>	<u>INPUT</u>	<u>ORDER PART #</u>	<u>LIST PRICE</u>
1	Burner Head & Black Heater Base	Nat. Gas	38,000 Btuh	Either JP-4BN6-CB-24 \$	959.00
		Propane	38,000 Btuh	or JP-4BL6-CB-24	959.00
2	One Piece Post - Hammered Black Finish			Plus JP-4PST-BK	106.00
3	32" Single Piece Reflector			Plus JP-4070-CB	90.00
Total List Price Hammered Black Finish \$					1,155.00

NOTE: No gas regulator is supplied with heater. Gas pressure to be regulated at gas supply by installer. Refer to installation manual for details.

* Ships in three separate cartons: 1: Burner Head & Heater Base + 2: One Piece Post + 3: Reflector

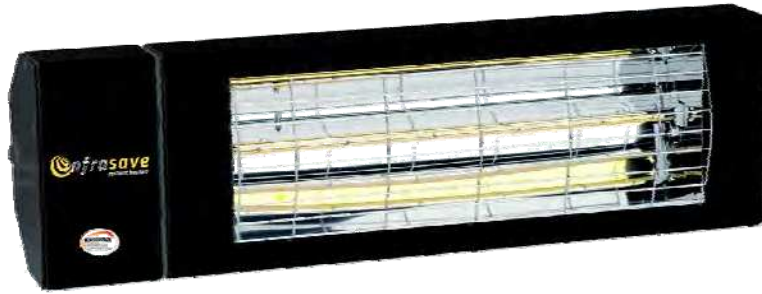

92% Radiant Efficient

Applications:

- Restaurant/hotel patios
- Sports venues
- Outdoor smoking areas
- Balcony/terrace
- Hobby shops
- Garage/workshop
- Warehouse facilities

IEP Series Electric IR Heater

Short-Wave IR for Instant Comfort

Available in Indoor and Outdoor / Indoor models
 1500 Watt heaters plug directly into standard 120V outlet
 2000, 3000, 6000 Watt heaters hard wire to 240V supply

<u>MODEL</u>	<u>Application</u>	<u>CAPACITY</u>	<u>Electrical</u>	<u>PART #</u>	<u>LIST PRICE</u>
IEP 1520	Indoor	1500 Watts	120Vac	IE-1520-12	\$ 345.00
IEP 2020	Indoor	2000 Watts	240Vac	IE-2020-24	395.00
IEP 1524	Outdoor / Indoor	1500 Watts	120Vac	IE-1524-12	345.00
IEP 2024	Outdoor / Indoor	2000 Watts	240Vac	IE-2024-24	395.00
IEP 3024	Outdoor / Indoor	3000 Watts	240Vac	IE-3024-24	715.00
IEP 6024	Outdoor / Indoor	6000 Watts	240Vac	IE-6024-24	1,095.00

Ideal for:

- **Enclosed or canopy covered patios**
- **'Tight' spots**
- **Longer gas pipe runs are impractical**

GAS CONVERSION KITS for *patio* SCHWANK HEATERS

*patio*Schwank 4000 Series heaters (*parasol* style) are not field convertible

When ordering, please provide heater model number and gas type to convert to

patio SCHWANK TUBE HEATER GAS CONVERSION KITS

<u>Heater Model</u>	<u>Input</u>	<u>NG to LP</u>	<u>LP to NG</u>	<u>List Price</u>
STR-JZ	{ 45,000 60,000 80,000 110,000 130,000 155,000	JS-0556-XA	JS-0556-XB	\$ 46.40
SPW-JZ		JS-0557-XX	JS-0558-XX	24.80
STS-WP		JS-0559-XX	JS-0560-XX	24.80
STW		JS-0561-XX	JS-0562-XX	24.80
STW-JZ		JS-0563-XX	JS-0564-XX	24.80
		JS-0565-XX	JS-0566-XX	24.80

patio SCHWANK LUMINOUS (HIGH INTENSITY) HEATER GAS CONVERSION KITS

<u>Heater Model</u>	<u>Input</u>	<u>NG to LP</u>	<u>LP to NG</u>	<u>List Price</u>
1110	29,500	JU-0349-XX	JU-0350-XX	\$ 48.00
1115	44,000	JU-0351-XX	JU-0352-XX	48.00
1120	59,000	JU-0353-XX	JU-0354-XX	48.00
1130	88,500	JU-0355-XX	JU-0356-XX	48.00
	<u>Input</u>	<u>NG to LP</u>	<u>LP to NG</u>	
2312	23,000	JX-0253-XE	JX-0252-XE	\$ 48.00
2313	35,000	JX-0253-XF	JX-0252-XF	48.00
2315	50,000	JX-0253-XG	JX-0252-XG	48.00



PRODUCT WARRANTY PERIODS

The following warranty periods are effective on all shipments on or after April 1, 2011.

Since 1951 Schwank has maintained a reputation of building quality industrial heaters. For this reason, and for our customer's protection, Schwank is prepared to support its heating equipment with the most comprehensive warranties in the industry.

Schwank warrants to the Purchaser that Schwank gas fired infra-red radiant space heaters and all parts, are free from defects in material or workmanship under normal use and service for the following periods of time.

Schwank Product	WARRANTY TERM (YEARS)					
	All Heaters	Luminaus	Tube Heaters		Parasel	
	Components	Ceramic Tile	Burner Cup	Radiating Tubes	Burner	Mantle
PATIOSCHWANK HEATERS:						
- sportSchwank	3	15				
- 2300	1	3				
- 3000: SPW-JZ & STW-JZ	3		10	10		
- 4000 Series	1				3	3
- IEP Electric IR	1					

OPTIONAL ACCESSORIES AND REPLACEMENT PARTS ARE COVERED UNDER THE PART MANUFACTURER'S WARRANTY: TYPICALLY 1 YEAR

Product warranties consist only of providing a like replacement part for any defective part during the term of the warranty, F.O.B. Schwank.

Please note, that the above does not constitute a description of product warranty. This table is intended only as a summary of general warranty term information and is subject to change without notice.

A complete product warranty statement is supplied within each product manual.

2 Schwank Way, Waynesboro, Georgia 30390 USA
5286 Bradco Blvd., Mississauga, Ontario L4W 2A8 CANADA
Tel: 1-877-448-3727
Fax: 1-888-381-0628
Email: csr@schwankgroup.com
Website: www.schwankgroup.com



PATIO HEATING SURVEY



FOR:

*BUSINESS NAME:	_____
*ADDRESS:	_____

*PHONE:	_____
*FAX:	_____
E-MAIL:	_____
*CONTACT PERSON:	_____

SURVEY PERFORMED BY:

DISTRIBUTOR NAME:	_____
MANUFACTURERS REP:	_____
*YOUR COMPANY:	_____
*ADDRESS:	_____

*PHONE:	_____
*FAX:	_____
E-MAIL:	_____

**On a separate sheet include a floor plan sketch and a cross section, and/or view of adjacent wall(s) showing any windows, doors, roof (canopy), fences, or any other encumbrance to heater location. Be certain to include all dimensions - "inches" are critical in heater placement.

NOTE: PATIO HEATING DESIGNS ALLOW FOR A WIND CONDITION OF 10 MPH or 15 Km/Hr.
PATIOS WITH WIND BREAKS PROVIDE BEST PATRON COMFORT.

*** INDICATES REQUIRED INFORMATION**

***TYPE OF GAS:**
 Natural Propane
(Indicate location of meter, tank or gas main on sketch)

***WHAT SEASON WILL PATIO BE OPEN:**
 Summer Autumn
 Spring Winter

***PATIO LOCATION:**
 Ground Level 1st Floor Roof
 Elevated above Ground
 Other _____

***ARE THERE ANY PATIO HEATERS NOW:**
 Yes No
 What Kind: _____

***ENTIRE PATIO TO BE HEATED:**
 Yes No

***IS THERE A ROOF / CANOPY OVER PATIO:**
 Yes No
 Where: _____
Height to bottom of joist / canopy:
 Highest Point: _____
 Lowest Point: _____
 Roof Construction: _____
 Material: _____

***DOES PATIO BUTT UP AGAINST A WALL:**
 Yes No
 Height: _____
 1 Side 2 Sides 3 Sides 4 Sides
(If YES, please indicate on you sketch)

***ARE THERE ANY OTHER HEIGHT RESTRICTIONS:**
 Yes No
Where & How High
 Building Overhangs: _____
 Decorative Beams: _____
 Permanent Umbrellas: _____
 Trees: _____
 Signs: _____

***MAY HEATERS BE MOUNTED ON WALL:**
 Yes No
(If YES, please indicate which wall on you sketch)

***IS THERE A FENCE ON ANY SIDE OF PATIO:**
 Yes No
 Height: _____
 1 Side 2 Sides 3 Sides 4 Sides
 How much breeze will fence(s) block _____ %

***PATIO LICENCED FOR HOW MANY PATRONS:**
 Quantity: _____
 Number of Tables: _____
 Size of Tables: _____
 Number of Chairs: _____
 Number of Bar Stools: _____

***IS THERE INTENTION TO ADD BREEZE BREAKERS:**
 Yes No
 Where: _____
 Height: _____

(IF THE PATIO OR AREA HAS ANY OTHER SPECIAL CIRCUMSTANCES, PLEASE INDICATE ON YOUR SKETCH)

The standard turnaround time is 48 hours, Schwank will endeavour to accommodate earlier requirements.