

Delta Cooling Towers Inc.

TM SeriesTM Cooling Tower

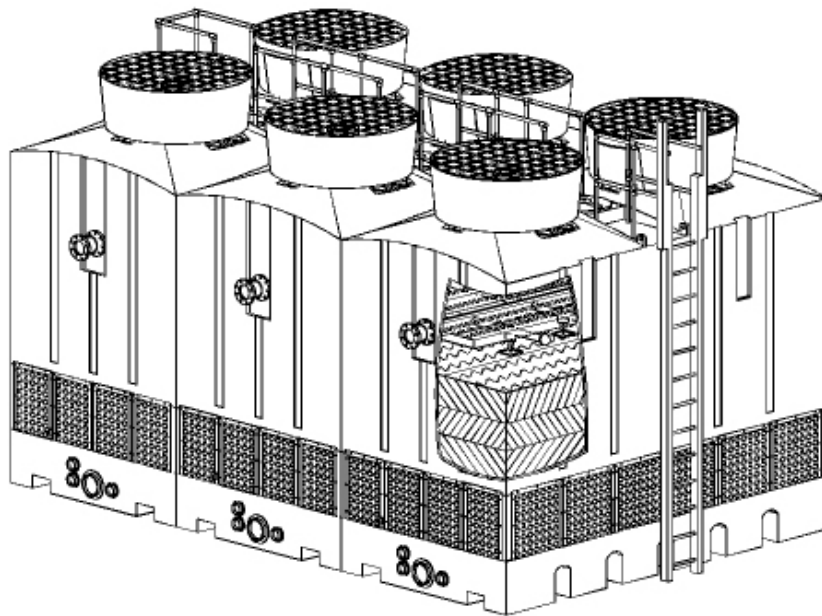

Installation, Operation & Maintenance Manual

WARNING.....

*Before unloading tower, read entire manual and follow instructions.
Failure to do so could void Warranty*

Table of Contents

Delta Cooling Towers	Principle of Cooling Towers.....	3
	Cooling Tower Terms and Definitions.....	3
	Water Treatment.....	4
	Safety.....	4
General Information	Approximate Weights & Dimensions.....	5
	Other Physical Data.....	6
Handling & Installation	On-Site Inspection.....	7
	Off Loading.....	7
	Installing.....	8
	Anchoring.....	12
	Electrical Wiring of Fan Motor & Accessories.....	13
	Handrail and Ladder.....	14
	Location, Piping & Connections.....	16
PVC Solvent Cementing Instructions.....	16	
Operation and Maintenance	Safety in Operation of the Fan.....	18
	Water Distribution System.....	18
	Operating Water Pressure.....	19
	Fan & Mechanical Drive System.....	19
	Motor Lubrication Instructions.....	19
	Start-up Instructions.....	20
	Water Level in Tower Sump.....	21
	Cold Weather Operation.....	22
	Trouble-Shooting Guide.....	24
Motor Trouble-Shooting Guide.....	26	
Other Information	Cooling Tower Optional Accessories.....	27
	Recommended Replacement Parts.....	27
	Preventative Maintenance Checklist.....	28

Important: Delta’s cooling towers have been designed to provide trouble-free service over an extended period of time. To obtain the design performance, it is necessary that the cooling tower be installed, operated and maintained as prescribed in these instructions.

Only persons possessing the skill and experience described herein should attempt to install this equipment. **Prior to installation, these instructions should be read carefully** by the person who is to install the cooling tower to be certain that its installation, operation and maintenance are thoroughly understood.

Questions regarding the installation, operation or maintenance of this equipment should be directed to Delta Cooling Towers, Inc., (Telephone: 973/586-2201).

Step-by-step instructions contained in this brochure are based on normal installation conditions only. Abnormal or unusual combinations of field conditions should be brought to the attention of Delta Cooling Towers or its representative prior to installation of the equipment. The information contained herein is subject to change without notice in the interest of product improvement.

If installation instructions are not clearly understood, consult Delta Cooling Towers for additional information before commencing erection.

Improper Storage, Handling, Installation, or Field Modifications of equipment may result in damage and loss of warranty protection.

Delta Cooling Towers

Principle of Cooling Towers

All Cooling Towers operate on the principle of removing heat from water by evaporating a small portion of the water that is recirculated through the unit.

The heat that is removed is called the latent heat of vaporization.

Each one pound of water that is evaporated removes approximately 1,000 BTU's in the form of latent heat.

Cooling Tower Terms and Definitions

BTU - A BTU is the heat energy required to raise the temperature of one pound of water one degree Fahrenheit in the range from 32° F. to 212° F.

Cooling Range - The difference in temperature between the hot water entering the tower and the cold water leaving the tower is the cooling range.

Approach - The difference between the temperature of the cold water leaving the tower and the wet-bulb temperature of the air is known as the approach. Establishment of the approach fixes the operating temperature of the tower and is a most important parameter in determining both tower size and cost.

Drift - The water entrained in the air flow and discharged to the atmosphere. Drift loss does not include water lost by evaporation. Proper tower design and operation can minimize drift loss.

Heat Load - The amount of heat to be removed from the circulating water within the tower. Heat load is equal to water circulation rate (gpm) times the cooling range times 500 and is expressed in BTU/hr. Heat load is also an important parameter in determining tower size and cost.

Ton - An evaporative cooling ton is 15,000 BTU's per hour.

Wet-Bulb Temperature - The lowest temperature that water theoretically can reach by evaporation. Wet-Bulb Temperature is an extremely important parameter in tower selection and design and should be measured by a psychrometer.

Pumping Head - The pressure required to pump the water from the tower basin, through the entire system and return to the top of the tower.

Make-Up - The amount of water required to replace normal losses caused by bleed-off, drift, and evaporation.

Bleed Off (Blowdown) - The circulating water in the tower which is discharged to waste to help keep the dissolved solids concentration of the water below a maximum allowable limit. As a result of evaporation, dissolved solids concentration will continually increase unless reduced by bleed off.

Water Treatment

- Proper water treatment will dramatically increase the working life and efficiency of your cooling tower fill and associated piping and components.
- The Delta Cooling Towers are manufactured from corrosion-resistant plastics which are resistant to water treatment chemicals including common fungicides and bactericides.
- Follow appropriate water treatment practices as required and take frequent sample tests to avoid possible water contamination. We also recommend water treatment maintenance as a measure of protection of the environment in the vicinity of any cooling tower or other equipment open to atmosphere.
- To determine the appropriate water treatment practices for your particular application, it is suggested that you contact a water treatment firm for their recommendation. (A list of water treatment firms is available for your reference. It is not necessarily complete nor do we recommend a specific firm. The list will be e-mailed to you on request or consult your local directories)
- Bleed-off is also important to water quality. Evaporation of the recirculated water does not remove the dissolved solids that are present in the water. Without bleed-off, the continual buildup of these solids will impair the proper functioning of the piping and other equipment in the system.
- **A COMPETENT WATER TREATMENT PROGRAM SHOULD NEVER BE CONSIDERED OPTIONAL.**

Safety

When handling, lifting, installing or operating the cooling tower, always employ safe work procedures according to best practices of the trade and according to applicable construction, electrical and safety standards, regulations and codes.

Follow all safety practices described in these instructions.

General Information

Approximate Weights & Dimensions

The TM Series cooling towers are manufactured in three basic sections; a polyethylene tower body, a polyethylene sump, and a fan assembly section. The tower body ships with the fan assemblies installed. The tower sump ships as a separate piece.

Approximate Weights (lbs.)				Overall Dimensions (inches)
Model Group	Shipping		Operating	L x W x H
	Body	Sump		
TM-103312 – TM-115412	4,950	1,200	11,800	198" x 102" x 186"
TM-203312 – TM-215412	(2) 4,950	(2) 1,200	23,600	198" x 204" x 186"
TM-305312 – TM-315412	(3) 4,950	(3) 1,400	35,400	198" x 306" x 198"
TM-405312 – TM-415412	(4) 4,950	(4) 1,400	47,200	198" x 408" x 198"
TM-505312 – TM-510412	(5) 4,950	(5) 1,400	59,000	198" x 510" x 198"
TM-605312 – TM-610412	(6) 4,950	(6) 1,400	70,800	198" x 612" x 198"

Other Physical Data

For cooling tower dimensions, design for foundations, assembly and layout; refer to the following drawings which are a part of these instructions:

Model Group	Title	Drawing No.
TM-103312 – TM-115412	1 Cell	DT-D-87-901
TM-203312 – TM-215412	2 Cell (3 - 7.5 HP)	DT-D-87-902
	2 Cell (10 – 15 HP)	DT-D-87-903
TM-305312 – TM-315412	3 Cell	DT-D-87-904-1 DT-D-87-904-2
TM-405312 – TM-415412	4 Cell	DT-D-87-905-1 DT-D-87-905-2
TM-505312 – TM-510412	5 Cell	DT-D-87-906-1 DT-D-87-906-2
TM-605312 – TM-610412	6 Cell	DT-D-87-907-1 DT-D-87-907-1

Handling and Installation of Your TM Series Cooling Tower

On -Site Inspection

Upon arrival at the job site, carefully inspect the shipment for any damage. If shipping damage has occurred, notify the driver or the carrier immediately and make a notation of the damage on the shipping bill of lading. Contact Delta Cooling Towers Customer Service to discuss proper methods of repair or replacement of damaged items before completing the installation. Always check that all items listed on the B/L have been received.

Offloading and Storing

The TM Series cooling towers are normally delivered to the site on a 30 inch high drop deck trailer. Both the tower main housing assembly and sump assembly are strapped down to the truck bed. The sump assembly should be unloaded first. **Prior to install and especially if stored for any period of time, the sump and main housing assembly must be stored upright on level ground providing consistent uniform support. DO NOT use any blocking between assemblies and ground.**

Lifting with crane:

- Use fabric slings of sufficient strength for better load distribution and protection of the plastic tower body.
- Wrap slings underneath tower sump assembly to lift and set into place.
- Lift tower main housing by attaching slings, kept separate by spreader bars, to the four lifting bars as shown below.
- Spreader bars must be used to lift vertically on the lifting bar. Above the spreader bars use adequate length straps specifically designed for vertical lifting in order to maintain an angle of 60° or less between slings.

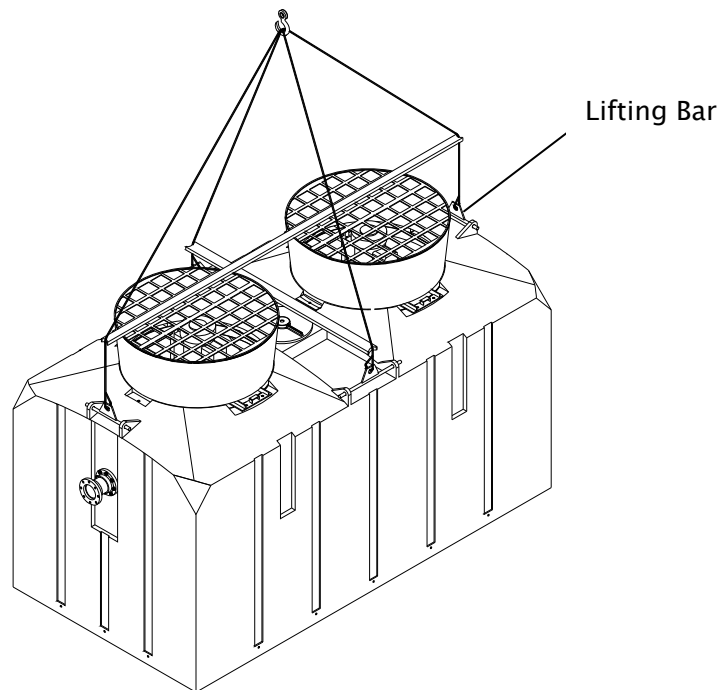

MAIN HOUSING – LIFTS NEAR GRADE

CAUTION: For extended lifts, use duplicate rigging, fabric slings around body as shown, as an additional safety precaution.

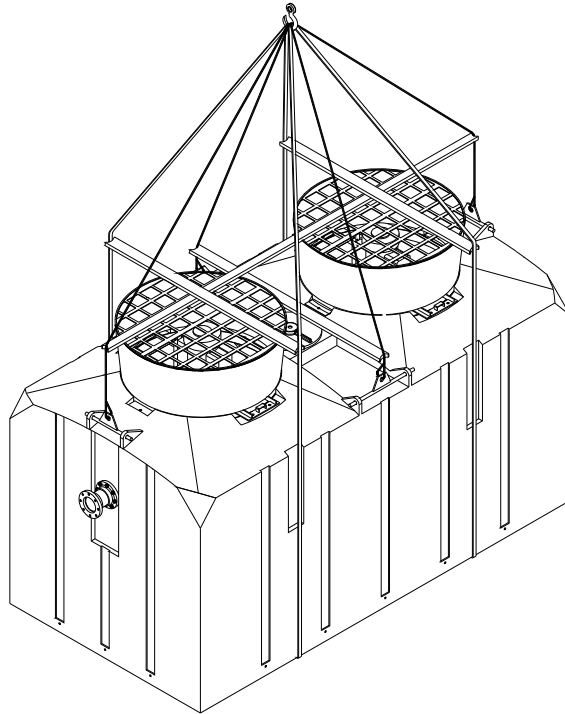

MAIN HOUSING - EXTENDED LIFTS

Installing

The cooling tower should be assembled in place on the previously prepared level foundation or I-Beams (**8” wide minimum; 8” – 10” recommended**).

- After re-checking the rigging, lift the sump section of each cell and secure properly to the foundation.
- Place the fiberglass sump box on the center support pedestals as shown.



- Body sections and sumps are color match marked. For multi-cell units, towers are to be lined up left to right looking at the outlet connection beginning with tower 1, then tower 2, etc. Inlet and outlet fittings are to be on the same side unless specified different on approval drawings. Ladders are mounted to the side to the left of the inlet as standard.
- Once the sump has been set on the support beams or pad it should be allowed to rest for a period of time prior to setting the upper housing
- The main housing section should then be lifted and carefully position to align the support post of the sump with the corresponding groove of the tower body. Note that the four corner posts are slightly higher than other post to ease installation alignment.
- Set one end of the tower posts onto the corner post at one end of the sump first. This can be accomplished by use of a rope tether attached to the lifting bar at one end of the housing. Continue setting and aligning support post along the sides of the tower moving from one end to the other. This step may require a couple of installers to align multiple posts simultaneously. You may use a pry bar to aid aligning post.



IMPORTANT: Make sure that all sump posts are correctly seated into the pocket of the main housing body.

- For single cell units, the four corner sump posts should then be secured to the main housing with the provided stainless steel angle brackets and hardware. On Multi-cell towers, only the outermost four corner posts should be secured to the main housing with the provided stainless steel angle brackets and hardware.



- Remove the temporary plastic “zip-tie” fasteners securing the above upper louver rubber deflector to allow the deflector to hang down. **DO THIS ONLY AFTER INSTALLATION IS COMPLETE.**



- Before installing PVC louver panels, verify that all post are correctly seated into the pockets of the tower body. **Allow the upper housing to settle on the sump for at least 24 hours prior to installing the louvers.**

- Install PVC louver panels between each support post. Panels are numbered and marked on top of each panel, and should be installed with corresponding numbered window opening. Insert bottom of panel into window opening and work your way up to the top. Panels should be mounted flush to the bottom of the louver opening with the air openings pointed down to direct incoming air downward. Secure panels with self-tapping screws provided ONLY in pre-drilled hole location in louver frame. Do not to over tighten these screws.



Louvers are numbered with the top identified. Each opening on the sump has a matching louver number.



Set the louver in the opening.



From inside the sump, confirm the louver is against the gasket. Adjust the gasket as needed.

- Once the cooling tower is operating, review all louvers for leaks and correct as needed. Caulking can be used to help seal leaks from louvers once proper installation is confirmed. Due to the high volume of water running through the cooling tower and cross-winds, some intermittent leaks around louvers can occur. This is more common when fans are not running.
- On multi-cell towers, install the PVC water redirecting panels between each sump (See sketch below). First, apply a heavy bead of RTV sealant along the underside perimeter of each vertical panel. Then, from bottom to top, secure to the tower post with the self-tapping screws provided. Repeat this process for the horizontal panels and then, from outside to inside, secure to the tower with the self-tapping screws provided. Do not screw the overlapping panels in the center in order to allow for expansion and contraction.

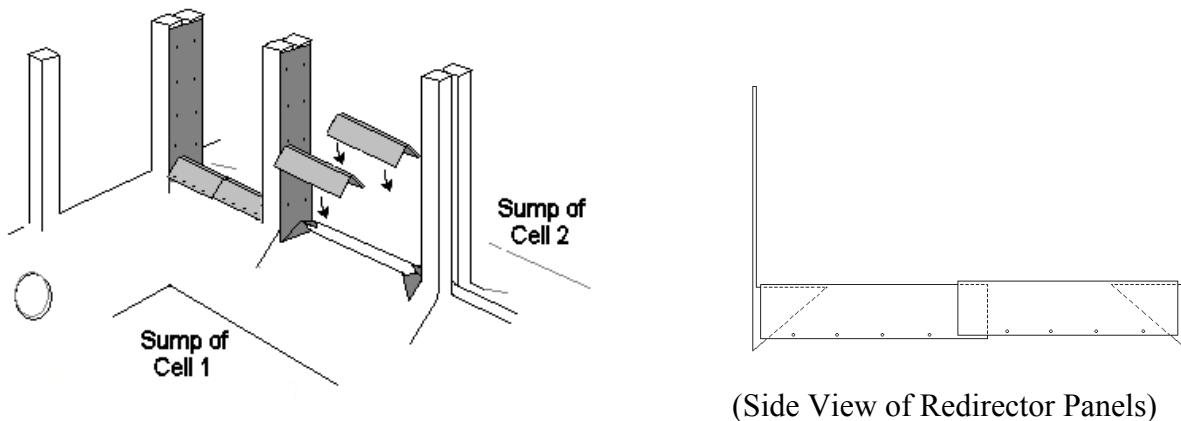

Multi Cell Water Redirectors

- Secure tops of adjacent multi cell units together by bolting the two aluminum support angle brackets provided to the lifting lugs of each cooling tower shell. The angle brackets should then be bolted together with hardware provided.

Anchoring

The foundation must be flat, smooth and rigid enough to be capable of independent support of the cooling tower assembly and water load in the sump at its maximum level. The tower assembly may be mounted on I-beams using the integrally molded I-beam pockets (See tower drawings). If tower is mounted and anchored to a concrete pad, the space between the anchor lug and the pad should be filled with grout or a rigid spacer.

- Four hold-down anchor lugs are provided on the sump of each tower cell



- Support beams and anchor bolts are to be furnished by others.
- Beams should **HAVE A MINIMUM TOP FLANGE WIDTH OF 8” (W8x31 RECOMMENDED)** and be in accordance with acceptable structural design practices. These beams should be located in the integrally molded I-beam pockets, and should over-run the length of the unit.
- **DO NOT WELD OR BOLT DOWN BEAMS PRIOR TO SETTING THE COOLING TOWER SUMPS.**
- Use anchor bolts sized for a minimum of 15,000 lbs. pull-out load per anchor lug for wind loading.
- Vibration isolation is optional with a Delta cooling tower. HDPE does not transfer the majority of vibration to the supporting structure, as does a steel tower. But, if spring isolators are installed they must NOT be affixed directly to the cooling tower anchor lugs. We recommend placing the springs between the I-beams and the supporting structure itself. (Please contact a licensed engineer for structural advice).

Electrical Wiring of Fan Motor and Accessories

- Installation of a vibration cut-out switch is recommended. (Refer to tower accessories available).
- All electrical work should be performed only by qualified personnel and in accordance to prevailing electrical codes, practices and safety standards.
- The motor starter should be sized on voltage, nominal horsepower, and maximum full load current. This current value can be found on the motor nameplate. If the starter cannot accept the maximum full load motor current, the next size higher should be used.
- Motor heaters should be selected on the basis of maximum full load current and service factors based on the motor nameplate.
- Standard “Cooling Tower Service” motors are supplied with a minimum of a 1.15 Service Factor.
- Optional two speed motors are single winding variable torque.

- Run flexible conduit with some slack from the motor conduit box to terminal box outside the tower where rigid conduit can be used.
- Conduit running vertically up the tower should be independently supported. No clips should be attached directly to the tower plastic.
- For the typical wiring schematic of fan motor and tower accessories, see Delta dwg. DT –B-78-001, included with these instructions. Each motor has a wiring diagram on the name plate or on the inside of the conduit box cover.
- A vibration cut-out switch (VCOS) should be installed with each fan assembly. Prior to operation, the VCOS needs to be adjusted for proper operation. Refer to the VCOS IOM provided.



Handrail and Ladder

Optional ladder and handrails can be provided with the cooling tower.

- 1) Handrails are shipped loose, normally in the sump.
- 2) The closed end of the handrail is to be located on the same end as the installed kick-plate.
- 3) Installed on the top of the cooling tower are handrail fittings for the handrail section to slide in. Set the handrail section in the installed fittings. A set screw in the fitting holds the handrail in position.
- 4) For a single TM, the handrail assembly is completely assembled and only needs to be set in place. For multiple cell TMs, the handrail assembly will be in sections that are attached using short sections of pipe.
- 5) Place the ladder up to the tower. Aluminum angle will line up with the lifting lug. Bolt the angle to the lifting lug with hardware provided.
- 6) The upper section of the ladder will line up with a portion of the handrail that extends beyond the tower. Match drill the handrail to the ladders pass-thru rails and bolt with hardware provided.
- 7) At the bottom of the ladder are pre-drilled aluminum angles. These are to be used to secure the ladder at the bottom.



Handrail components shipped loose.



The kick-plate will be away from the ladder. Handrail fittings are already installed in place on the cooling tower. The handrail fitting has a set screw for securing the aluminum pipe.



Bolt the ladder into the lifting lug.

Match drill the ladder to the handrail.



Anchor brackets located at the bottom of the ladder.

Location, Piping and Connections

- Piping should be adequately sized in accordance with accepted standard practices.
- Piping must be supported independent of the tower. Do not pull tower flanges into mating flanges. Supporting piping with tower will cause leakage and/or damage.
- **All tower inlet and outlet piping should be field fabricated and assembled based on installed tower dimensions. Do Not Prefab any interconnecting piping.**
- Gravity drain to indoor storage sump requires proper head differential and piping design considerations. Allowance must be made for flow, pipe size, piping layout and distance of cooling tower from the indoor storage sump.
- When multiple single cell towers or multiple multi-cell towers are to be installed at the same site, a minimum clearance of 6'-0" must be maintained between towers. This clearance is also necessary between each tower and any external obstructions (walls, buildings, fences, etc.). Please consult Delta Cooling Towers Inc. for a decision on any reduced clearances.
- 6'-0" clearance is also necessary between each tower and any external obstructions (walls, buildings, fences, etc.). Walls and buildings should be limited to no more than 18'-0" above the tower base to prevent warm air recirculation. Please consult Delta Cooling Towers Inc. for a decision on any reduced clearances or for obstructions greater than 18'-0" tall.
- On multiple cell installations, valving and/or pipe sizing should balance pressure drops to provide equal inlet pressures. Equalizing fittings are provided in the sumps of each cell and can piped together to balance sump water level. Each cell should be valved separately to allow for flow balancing or isolation from service.
- Prior to start-up, confirm that the PVC locknuts on all bulkhead fittings are properly tightened to prevent nuisance leaks. A chain wrench can be used to check and tighten the locknuts.
- Check that the SS hexagonal nuts on the inlet and outlet PVC flanges are properly tightened to prevent nuisance leaks. While tightening the nuts, do not allow the bolt to rotate. This could damage the rubber seal under the flat washer on the bolt head located inside the cooling tower.
- All supply and return piping must be independently supported.

PVC Solvent Cementing Instructions

The following procedure is recommended for the preparation and cementing of internal and external piping for Delta Cooling Towers:

- Cut ends of pipe square using a handsaw and miter box. Tube cutters with wheels designed for use with PVC are acceptable, providing they do not leave a raised bead on the outside diameter of the pipe.
- Use a chamfering tool or file to put a 10° to 15° chamfer on the end of the pipe. Lightly sand the area to be cemented to remove gloss. Using a clean rag, wipe pipe surface and fitting socket to remove dirt, moisture and grease. Acetone or similar solvent is recommended for cleaning.
- Check "dry fit" of pipe and fitting by inserting pipe at least 1/3 of the way into the fitting. Position pipe and fitting to assure alignment. Pipe and fitting should be at same temperature condition.
- Using a clean, natural bristle brush about 1/2 the size of the pipe diameter, apply a primer to the fitting socket. Apply primer with a scrubbing motion until the surface is penetrated. Primer should never be applied with a rag. Repeated applications may be necessary to achieve the desired dissolving action. In the same manner, apply primer to the pipe surface equal to the depth of the fitting socket, making sure the surface is well penetrated. Reapply primer to the fitting socket to make sure it is still wet.
- While both surfaces are still wet with primer, use a clean brush to apply a liberal coat of solvent cement to the male end of the pipe. The amount should be more than sufficient to fill any gap. Next apply a light coat of solvent cement to the inside of the socket, using straight outward strokes to keep excess cement out of the socket.
- While both surfaces are still wet with solvent cement, insert the pipe into the socket with a quarter-turn twisting motion. The pipe must be inserted the full length of the socket. The application of solvent cement to pipe and fitting, and the insertion of the pipe into the fitting, should be completed in less than one minute. If necessary, two persons should apply solvent cement to the pipe and fitting simultaneously.
- Hold the joint together for approximately 30 seconds until both surfaces are firmly gripped. After assembly, a properly made joint will usually show a bead of cement around its entire perimeter. This should be brushed off. It is recommended that the joint be allowed to cure for 24 hours before pressure testing or operation.

Operation and Maintenance of Your TM Series Cooling Tower

Safety in Operation of the Fan

NEVER operate the fan when the access panel or the entire fan guard is removed.

NEVER remove access manhole cover while fan is in operation.

NEVER operate fan when any work, access, maintenance, trouble-shooting, etc. is being performed on the inside of the fan ring assembly or inside the tower plenum.

- Normally, electrical codes dictate a disconnect box at the cooling tower.
- The handle of the disconnect box **must be locked in the off position and an OSHA DANGER tag (DO NOT OPERATE) must be attached to handle securely.**

Note: Removing fuses from the disconnect box may provide further assurance, but only when done by qualified personnel.

The foregoing precautions apply when any type of internal access to the tower is required, including the following examples:

- Checking, maintenance or replacement of any fan assembly component.
- Checking, maintenance or replacement of the water distribution system inside the tower.
- Cleaning of the fill.
- Any work that necessitates removal of any access door, the fan guard or the manhole cover.

Water Distribution System

Water distribution is accomplished by a low pressure, non-rotating, spray nozzle system designed to accommodate the specified flow rate.

IMPORTANT:

- The flow rate of the cooling tower must be as close to the design gpm as possible. The water distribution systems, including spray nozzles, are provided for the design flow condition. Under-pumping or over-pumping will cause the cooling tower to perform inefficiently.
- Design pressure at the inlet connection must be maintained for proper water distribution and tower performance.

If the pressure is less or greater than the design, proper water dispersion over the internal wet decking will be impaired. If inlet pressure is low, water spray will not cover the entire wet decking surface. This causes channeling of air, and does not make maximum use of the heat transfer media. High inlet pressures will cause the water to over-spray the wet decking media, hit the internal side walls of the tower shell and drop in a vertical flow along the shell walls without the opportunity for water / air contact through the heat exchange media. Excessive high spray pressure may also cause wet decking fatigue and damage.

- *The operating inlet pressure should be between 4.0 and 5.5 psi at the tower inlet.*
- The maximum operating inlet water temperature should not exceed 140° F with standard fill, special high-temp options available for order.

CAUTION:

When stepping on top of the fill, distribute the body weight by means of two plywood plates on top of fill.

Fan and Mechanical Drive System and Its Maintenance

Safety

Follow all safety instructions previously discussed.

Motor:

- The standard motor is a totally enclosed motor , Class F insulation, 1.15 minimum service factor, epoxy coating on outside frame, and is specifically designed for cooling tower duty to the exclusive specifications of Delta Cooling Towers.
- Should there be a problem with the motor, which may be covered under our standard warranty, the motor **must only** be inspected and serviced by an authorized motor manufactures warranty shop, and Delta Cooling Towers, Inc. must be notified, otherwise the warranty is void.
- If the motor bearings have grease fittings, follow the lubrication recommendations as outlined in instructions from motor manufacturer. The majority of motors do not require greasing.

Motor Lubrication Instructions

If lubrication instructions are shown on the motor nameplate or in motor instructions provided by the vendor, they will supersede this general instruction.

- 1) Stop motor. Disconnect power and lock out service.
- 2) Remove contaminants from grease inlet area.
- 3) Remove filler and drain plugs.
- 4) Check filler and drain holes for blockages and clean as necessary.
- 5) Add proper type and amount of grease. See the lubrication Time Intervals table for service schedule and lubrication Amount table for volume of grease required. This information is provided by the motor manufacturer.
- 6) Wipe off excess grease and replace filler and drain plugs. If motor is name-plated for hazardous locations, do no operate motor without all grease or drain plugs installed.
- 7) Motor is ready for operation

Start-up Instructions and Checklist

Complete all start-up instructions before applying heat load.

Check that all installation procedures were followed, including:

- If installed using I-beams, verify 8” minimum top flange (8” – 10” recommended).
- If slab mounted, verify 15,000 lb pull anchors.
- On multi-cell installations, verify that the upper cell connectors were installed.
- On multi-cell installations, verify that the water redirectors were installed.
- Verify the installation of the four corner brackets. (4 outermost corners only).
- Check the upper louver rubber deflector for pinching or perforations. Be sure to remove the temporary cable ties after installation.
- Verify the functionality of the optional vibration cut-out switch.
- Clean any accumulated debris or packaging material from inside tower sump.
- Check to be sure that the fan motor is properly wired for correct rotation as viewed from the top of the fan. Reverse leads will cause incorrect rotation and reverse direction of airflow.
- Cable ties that are used to temporarily support the upper louver rubber deflector during transport need to be removed after assembly and before start up.
- ***Note: Fan rotation should always agree with rotation labels. Standard fan rotation is clockwise. However, non-standard fans may be designed to rotate counter clockwise.***
- Manually check for free rotation of the fan and fan blade tip clearance. Use Lock out Tag out.
- Fill the cooling tower sump or the cold water storage reservoir on gravity drain applications.
- Water recirculation pump should be primed and all piping below the tower sump filled with water. Check pump for proper shaft rotation.
- Start water recirculation pump and adjust flow to design. A flow metering device installed in the inlet is recommended, but if not available, use the pressure differential across the pump in conjunction with the pump curve.
- Check spray pattern from nozzles to be sure there is no clogging. Remove 2-3 drift eliminator panels from the man-way cover area for nozzle inspection, and then return to their proper position.
- Start up fan motor and check amperage and voltage against motor nameplate data.
- The standard make-up valve assembly is shipped with the plastic float ball strapped against the tower side to prevent damage. To set the ball for proper operation, loosen the screw in the fulcrum arm, lift or depress the arm with the plunger pressed against the valve seat and tighten. Repeat until the proper operating level is obtained (Refer to operating level table below). It is recommended that a shut-off valve be installed in the make-up line in case of failure. 60PSI maximum incoming water pressure. Be sure that the valve is perpendicular to the water level. A few degrees off will cause the valve not to open or close properly.
- After 24 hours of operation:
 - Check spray nozzles for clogging.

- ❑ Check tower sump water level.
- ❑ Check for any water leaks.

Water Level in Tower Sump

When the cooling tower is being operated with pump-suction, the make-up valve assembly with float ball should be adjusted to set the water operating level as follows:

Tower Model #	Operating level (from bottom of sump)
All Towers	10 inches

Note: Bottom of the standard overflow is 11.5". For systems requiring a higher sump level, an overflow extension can be provided. This raises the overflow to 16".

- Access the make-up valve through the window louver marked "Access Panel".
- A lower water level than recommended may cause air to be drawn into the tower outlet piping and cause pump cavitation.
- A water level higher than recommended will cause continuous overflow and waste of water as a result of potential "pull-down" from the piping when the system is shut down.
- The overflow should **NEVER** be capped, or its elevation altered by raising external piping.

Note: On gravity drain cooling tower(s), make-up assembly, overflow, drain and vortex breaker are not provided.

Cold Weather Operation

Cold Weather Protection

The cooling tower may require protection against freezing at light heat loads when the wet-bulb temperature is under 32°F., or during shutdown when the temperature drops below 32°F.

The following methods are recommended for use in Delta Cooling towers for protection during cold weather conditions. Recommended equipment is optional and may be ordered from the factory. Consult the factory for further information on which equipment to choose for your specific application.

Separate Indoor Sump

This method is virtually a foolproof antifreeze protection system with the added advantage of minimum maintenance. The indoor sump tank should be large enough to fill the entire recirculation system without danger of pump cavitation. As a general rule, the tank should be sized to hold three times the rate of circulation in gallons per minute (gpm).

The tank should be provided with properly sized overflow, make-up drain and suction connections. When a separate sump is ordered with a cooling tower, the water make-up valve assembly and the overflow and drain connections are installed in the indoor sump only.

When a sump tank is used, the cooling tower should be located high enough above it to allow free cold water gravity drain. A bottom outlet can be provided for gravity drain to indoor sump tank installations.

Reverse siphoning is a back flow of non-potable, recirculating water into a potable water system, which can occur through the make-up float valve assembly located in the water reservoir. Should the valve malfunction, blockage of the overflow or outlet lines would cause water level to rise in the reservoir, and the make-up water pressure could drop below the atmospheric pressure creating a vacuum at the make-up inlet. Although precautions to prevent reverse siphoning are incorporated in the cooling tower design, we also recommend installing a check valve in the water make-up supply line, as a backup precaution.

Electric Immersion Heater for Sump

Cooling towers ordered with anti-freeze systems are shipped with a protective seat secured under the immersion heater element that is to remain in place during operation to protect the polyethylene shell from direct contact with the heater element.

*Note: This protective seat is **NOT** a shipping brace and **must not be removed.***

Final installation and wiring of the Heater Element, Control Panel, and Heater Probe must be completed in strict accordance with the enclosed manufacturer's Installation, Operation, and Maintenance Instructions. Failure to follow the manufacturer's IOM can lead to potential equipment damage and voiding of equipment warranties.

Thermostatic On/Off Control

A thermostatically controlled fan for on/off operation, should be considered as an energy saving feature, for capacity control during winter operation. The thermostatic control can be field set to insure automatic fan shut-down when cold water drops below design temperatures, as well as fan

start-up when cold water rises to design temperature.

A thermostatic control provides excellent cooling tower anti-freeze protection while reducing operating costs throughout cold weather operation.

PVC Distribution System

To prevent damage to the PVC distribution system during cold weather shut-down, install an automatic or manual drain line from the hot water inlet piping as close to the cooling tower inlet as possible. The entire inlet and distribution system must be drained for shut-down in sub-freezing weather.

Piping

When the cooling tower is located outdoors, adequate measures including the use of heating tapes and insulation should be considered to protect water lines from freezing.

Operation at Sub-freezing Ambient

See Thermostatic On/Off control

1. Insure that the cooling tower is operating at the maximum possible heat load - An operating cooling tower will continuously extract heat from the circulating water. Without a heat load, the water will end up either at the air wet bulb temperature, or as ice, whichever occurs first.
2. Maintain Design Water Flow Rate Over The Fill - Reducing water flow over the fill area can produce semi-dry regions that are subject to rapid freezing.
3. Make sure a thermostat is installed to control fan operation to off at low cold-water temperatures.
4. If tower is equipped with two speed motors, operate at low speed to increase leaving water temperature.
5. Cycle fans periodically to prevent ice from forming on louvers.
6. It may also be necessary to reverse fans for a short period of time to help melt ice by forcing warm water into tower.
 - De-energize the fan(s) for two full minutes before reversing.
 - Reverse fan(s) no more than 2 minutes at a time (repeat as necessary). Extended reverse operation can cause ice to form on fan blades causing an out-of-balance condition.
 - If the tower is equipped with a two-speed motor, reverse only at low speed.
 - On multi-cell towers, fans immediately adjacent to reversed fans should be shut off during reversal.
 - After reversal, let fan(s) stand idle 5 to 10 minutes before forward operation.
 - Monitor the tower closely for unusual vibrations or sounds.
7. Frequent visual inspections and routine maintenance during sub-freezing operation is very important and should not be overlooked.

Trouble-Shooting Guide For TM Series Induced Draft Cooling Towers

Problem	Possible Causes	Corrective Actions
Increase in the leaving water temperature	<ol style="list-style-type: none"> 1. Excess water flow; over pumping. 2. Recirculation of hot discharge air, back into the cooling tower air intakes. Obstructed air intakes 3. Proximity of other heat source or discharge of moist air. 4. Improper operation of spray system. <ol style="list-style-type: none"> A. Orifices clogged. B. Actual water flow is lower than design sprinkler rating. 5. Clogged fill. 6. Damaged fill. 7. Additional heat load on system. 8. Wet-bulb temperature higher than design. 	<ol style="list-style-type: none"> 1. Adjust to the design flow. 2. Eliminate obstructions which impede air discharge. For proper location of cooling tower(s), see Delta dwgs. Baffle air discharge, if necessary. 3. Remove source or relocate tower. 4. See water distribution system instructions. <ol style="list-style-type: none"> A. Flush spray nozzles, clean orifices, clean system, install outlet strainer. B. Install properly rated spray nozzles or increase to design flow. 5. Clean the fill. 6. Replace the fill. 7. Contact Delta for possible upgrade or addition of another cooling tower selected for additional load. 8. None required if condition is temporary. Otherwise consult Factory for upgrade.
Drop in the water flow rate. Low water flow rate	<ol style="list-style-type: none"> 1. Blockage of spray Nozzle orifices. 2. Low water level in sump causing air to be drawn into pump and piping. 3. Improper selection of water circulating pump. 4. Blockage of strainers. 5. Pump malfunction. 	<ol style="list-style-type: none"> 1. Flush spray nozzle. Clean whole system. Install outlet strainer. 2. Adjust float valves. Be sure the system is flooded and balanced. 3. Replace with proper size pump designed for flow and head requirements. Check pump "Net positive suction head." 4. Backwash or clean. 5. Consult pump specialist.
Noise and vibration	<ol style="list-style-type: none"> 1. Loose bolts. 2. Mechanical interference of rotating parts. 3. Fan propeller damaged or out of balance. 4. Air intake at pump. 5. Pump cavitation. 6. Damaged motor bearings. 	<ol style="list-style-type: none"> 1. Recheck and tighten all bolts to specified torque. 2. Inspect propeller for free rotation. Check propeller for mechanical interference. Adjust, repair or replace, as necessary. 3. Replace components, as necessary and check balance. Install vibration cut-out switch. 4. Check basin water level and irregular piping design. 5. Match pump NPSH with system hydraulics. 6. Check and replace motor.
Sudden or short term irregularities of cold water level in basin	<ol style="list-style-type: none"> 1. Peculiarities of specific system and its operation. 	<ol style="list-style-type: none"> 1. Inspect system and review operation procedures. Correct, as applicable valve settings, loss of water in system, fill system to flooded capacity.
Excessively high water level in sump on gravity drain installation	<ol style="list-style-type: none"> 1. Gravity flow restrictions due to insufficient head differential. 2. Airlock. 3. Unnecessary obstruction of water flow (i.e., partially closed valve). 4. Undersized piping. 5. Horizontal pipe run too long. 6. Improper hydraulic pipe design. 7. Outlet vortex breaker provided. 	<ol style="list-style-type: none"> 1. <ol style="list-style-type: none"> A. Outlet piping should terminate below sump tank water level. B. Increase discharge pipe size. C. Increase head by mean other than A. 2. Install an air bleed valve at highest point of piping, usually at a vertical angle. 3. Remove obstruction. 4. Increase pipe size. 5. Shorten, if possible. 6. Correct design. 7. Remove vortex breaker.

Problem	Possible Causes	Corrective Actions
Excessively high water level in tower basin on closed loop system installations	<ol style="list-style-type: none"> 1. Make-up valve float set too high. 2. Valve or float damaged or malfunctioning. 3. Make-up water pressure too high. 	<ol style="list-style-type: none"> 1. Readjust float arm. 2. Repair or replace. 3. Reduce pressure or contact Delta for alternate solutions.
Uneven water level in tower basins of multi-cell installations	<ol style="list-style-type: none"> 1. Unbalanced system hydraulics. 2. More than one make-up valve operating, and set for different water levels. 	<ol style="list-style-type: none"> 1. <ol style="list-style-type: none"> A. Install equalizer line with isolation valves between modules. C. Adjust inlet water flow to insure equal distribution to each cooling tower module. D. Review outlet header hydraulics and correct piping design, if applicable. E. Contact Delta for assistance. 2. <ol style="list-style-type: none"> A. Adjust float level settings relative To one another. B. Shut-off and or/throttle flow to one or more valves. C. Installation of equalizers is highly recommended.
Excessive water carry over (drift)	<ol style="list-style-type: none"> 1. Surfaces of top layer of fill damaged causing “pooling” of water. 2. Eliminator(s) not in place. 3. Damaged eliminator. 4. Excess water flow. 5. Orifices in spray nozzles clogged causing improper water dispersment. 6. Blockage of fill. 	<ol style="list-style-type: none"> 1. Replace top layer. Protect fill when working inside tower. 2. Reinstall. 3. Replace. 4. Reduce water flow or install spray nozzles designed for the actual operating flow. 5. Install outlet strainer. Clean whole system and spray nozzles. 6. Clean fill.
Premature or excessive corrosion of fan drive components	<ol style="list-style-type: none"> 1. Excessive drift. 2. Presence of corrosive chemicals in air or water that was not known at time of supply. 	<ol style="list-style-type: none"> 1. See “Excessive Water Carry Over (Drift)” above. 2. Remove source of corrosion or contact Delta for alternative materials, premium coatings or other precautions.

Motor Trouble Shooting Guide (General)

Problem	Possible Causes	Corrective Actions
High current draw (all 3 phases)	<ol style="list-style-type: none"> 1. Low line voltage (5 to 10% lower than nameplate). 2. 200V motor on 230/240V system. 3. 230V motor on 208V system. 4. Incorrect propeller. 5. Incorrect pitch if adjustable 	<ol style="list-style-type: none"> 1. Consult Power Company. 2. Change to 230V motor. 3. Change to 200V or 280V motor. 4. Consult factory. 5. Reduce pitch / consult factory
Low motor current draw	<ol style="list-style-type: none"> 1. Incorrect propeller. 2. Incorrect pitch if adjustable. 	<ol style="list-style-type: none"> 1. Consult factory 2. Increase pitch / consult factory
Unbalanced current (5% from average)	<ol style="list-style-type: none"> 1. Unbalanced line voltage due to: <ol style="list-style-type: none"> A. Power supply. B. Unbalance system loading. C. High resistance connection. D. Undersized supply lines. 2. Defective Motor. 	<ol style="list-style-type: none"> 1. Consult Power Company and/or electrician. 2. Replace motor.
Excessive voltage drop (2 or 3% of supply voltage)	<ol style="list-style-type: none"> 1. Inadequate power supply. 2. Undersized supply lines. 3. High resistance connections. 	<ol style="list-style-type: none"> 1. Consult Power Company. 2. Increase line sizes. 3. Check motor leads and other connections.
Overload relays tripping	<ol style="list-style-type: none"> 1. Overload. 2. Unbalanced input current. 3. Single phasing. 4. Excessive voltage drop. 5. Frequent starting or intermittent overloading. 6. High ambient starter temperature. 7. Wrong size relays. 8. Improper overload settings of adjustable relays. 	<ol style="list-style-type: none"> 1. Reduce load on motor or increase motor size. 2. Balance supply voltage. 3. Eliminate. 4. Eliminate (see above). 5. Reduce frequency of starting and overloading or increase motor size. 6. Reduce ambient temperature. 7. Correct size per nameplate current and service factor. 8. Readjust to motor FL Amps x S.F.
Motor runs very hot	<ol style="list-style-type: none"> 1. Overloaded. 2. Blocked ventilation. 3. High ambient temperature. 4. Unbalanced input current. 5. Single phased. 	<ol style="list-style-type: none"> 1. Reduce overload. 2. Fouled fill or air restriction. 3. Reduce ambient temperature. 4. Balanced supply voltage. 5. Eliminate.
Motor will not start	<ol style="list-style-type: none"> 1. Single phased. 2. Rotor or bearings locked. 	<ol style="list-style-type: none"> 1. Shut power off – eliminate. 2. Shut power off – check shaft rotation.
Excessive vibration (Mechanical)	<p>Out of balance</p> <ol style="list-style-type: none"> 1. Motor mounting. 2. Motor. 	<ol style="list-style-type: none"> 1. Check to be sure motor mounting hardware is tight. 2. Replace motor.

Note: Consult Warranty page prior to replacing or repairing any cooling tower components. Delta recommendation and consent to remedy material and workmanship defects is necessary, to avoid breach of Warranty.

TM Series Optional Accessories

TM Series Optional Accessories Available

- Aluminum Ladder(s) with a step platform and railing at the fan elevation **custom designed** for the cooling tower.
- Safety cage(s).
- Variable frequency drive on fan motors, controlled by temperature controller.
- Two speed motor(s) designed for cooling tower duty to the exclusive specifications of Delta Cooling Towers.
- Vibration cut-out switch provides for fan motor circuit disconnect for shutdown protection should abnormal fan vibration develop during service. Installation of vibration cut-out switches **is recommended** as good safety practice.
- Thermostat on/off control of fan operation through sensing the temperature of water leaving the tower.
- Basin anti-freeze system for cold weather operation.
- Custom designed top platform with handrails.
- Pre-wired control panels.
- Elevated mounting frame structures.
- Pumps
- Polyethylene Sump tanks up to 10,000 gallons for indoor installation for anti-freeze protection during winter operation.
- Motor space heaters are recommended for unusually high relative humidity conditions where extreme day to night temperatures can cause excessive condensation in the motor, when in operation during this period.
- Outlet sump strainer.
- High sump level switch
- Automatic drain valve

Consult factory or a Delta representative for further information and an updated list of accessories.

TM Series Recommended Replacement Parts

To avoid costly cooling tower downtime, the following replacement parts should be carried in inventory at the installation site:

- Make-up valve assembly.
- Cartridge of recommended moisture resistant lubricant.
- Fan Motor.
- Spray Nozzles.
- Louver Panels.

When ordering, include model number and serial number of the cooling tower as it appears on the tower nameplate. Under normal conditions, shipment of factory replacement parts is made within one day after the order is received. Spare pumps and pump parts, as well as control panel components, such as fuses and heaters for magnetic starters, are also available.

Preventative Maintenance Checklist

Procedure	Monthly	Every 3 Months	Every 6 months
Inspect General Condition of cooling tower.	◆		
Check Water Level in cold water basin. Adjust if needed.	◆		
Check float ball & Make-up Valve for proper operation.	◆		
Check Line Voltage, Motor Amperage, Water Pressure.	◆		
Clean Sump Strainers , if installed.	◆		
Lubricate Motor Bearing, (if motor has fittings for greasing. The majority of motors require no external greasing). Use Proper Lubricants . Increase frequency, as necessary depending on conditions of service.		◆	
Check for obstructed Water Flow Through Orifices . Clean and flush spray nozzles, as required.		◆	
Check All Bolts that can cause unbalance and vibration. Retighten to specified torque. Also check for fan ring/motor corrosion that may lead to failure or dislodged pieces falling into the airstream.		◆	
Check Condition of Water for proper treatment to prevent build-up of algae and solids concentration		◆	
Clean and flush Cold Water Sump			◆