

Hydraulic Projects Ltd



PC45

Constant Running Marine Autopilot Hydraulic
Pump Installation and Service Instructions

Serial Number

“Engineering Excellence”

The information in this manual was, to the best of our knowledge, correct when it went to press and Hydraulic Projects Ltd cannot be liable for any inaccuracies or omissions. There may also be differences between the specifications in the manual and the product as a result of ongoing development for which we accept no liability.

Page	4	•	Important Safety Information
	5	•	Description
		•	Pump Size
		•	Location
	6	•	Hydraulic Connections
		•	Hydraulic Fluid
	7	•	Commissioning
		•	Trouble Shooting
	8	•	Service
		•	Filters
		•	Brushes
	10	•	Installation Details
	12	•	Technical Data
	13	•	Typical Performance
		•	Wiring details
	14	•	Typical Arrangements
	15	•	General Information
		•	End of Life Disposal
	16	•	Contact details

IMPORTANT SAFETY INFORMATION

Failure to install and maintain this equipment in accordance with the instructions contained in this Manual could result in damage or injury.

This equipment must be installed and maintained by a person who is qualified to do so. This equipment is only for use with marine Auto pilots within the limitations stated in the following pages.

Auto pilot steering systems are navigational aids and the user must still maintain a permanent watch.

This equipment meets the latest EMC (Electromagnetic Compatibility) standards required for use in the recreational marine environment. In order to ensure conformance and to prevent interference with electronic systems the unit must be properly bonded to earth and the supply cables screened.

DO NOT FLASH TEST

Beware of hot motor and solenoid components and the risk of entrapment from moving parts.

DESCRIPTION

"PC45" constant running type gear pumps are driven by 12 or 24 volt dc permanent magnet fan cooled motors. Flow reversal is achieved by switching a double acting solenoid valve. Incorporated in the design are pilot operated check valves that prevent the pump being back driven by the manual steering system.

Other features include compatibility with balanced or unbalanced cylinders and they can also be used with pressurised reservoir systems (max 3.5 bar).

A relief valve, variable speed control and an integral reservoir with filter are fitted as standard.

PUMP SIZE

Maximum flow output at no load is indicated on the rating plate. Check the voltage shown is correct for the output of your auto pilot.

LOCATION

These pumps are designed for 'under deck' installations only.

Excessive temperature, vibration and fumes in the atmosphere can drastically reduce motor brush life.

Mounting the unit on a flimsy surface can transmit and amplify undesirable noise.

As in common with other electrical equipment, contact with water and excessive humidity must be avoided.

Keep the cable and pipe work runs as short as practically possible.

Units must be mounted either horizontally, foot down or vertically, tank down (refer page 10)

This unit should not be positioned in a confined area where there are inflammable gases.

HYDRAULIC CONNECTIONS

The 'A' and 'B' ports are G1/4(BSP) parallel threaded, the 'R' port is G3/8 (BSP) parallel threaded.

Use only bonded rubber/metal washers to seal the fittings. Do not use tapered adapters, sealing compound or P.T.F.E tape.

Ports marked 'A' and 'B' are the service line connections to the ram, the pipe work and connections must be suitable for a 100 bar working pressure minimum rating.

The port marked 'R' is the reservoir or balance line. If used as a balance line it must be connected, through a continuous rise to the helm pump bottom connection.

Do not plug this port – damage and steering failure could result.

If used with pressurised reservoir type systems the pipe must be suitable for at least 7 bar.

Ensure that no dirt enters the system during the installation, be certain that all pipes and fittings are cleaned before connecting up.

HYDRAULIC FLUID

Good quality ISO VG10 to ISO VG42 hydraulic mineral oil is recommended, check the compatibility with the helm pump and ram manufacturers specifications and if it is suitable for use with nitrile rubber hydraulic seals.

Refer 'Recommended Oils'.

COMMISSIONING

CAUTION! Be aware of the danger of moving linkages and the risk of entrapment during this procedure.

Bleed the system according to the Helm Pump Manufacturers instructions. To aid clearing air from the electric pump please note the orientation of the hydraulic/electrical connections -See installation data.

The pump must not be run without oil.

Set the speed control to achieve the desired hard-over time (nominally 12 seconds). Screw in to reduce speed.

The relief valve is set at 58 Bar and should not be adjusted unless the steering gear is designed to operate at a lower pressure.

TROUBLE SHOOTING

1) Motor does not run

- : check electrical connections.
- : check auto pilot output.
- : check motor brushes.
- : check fuse / trip rating (Ref. page 10)

2) Motor runs, but no ram movement.

- : check that the solenoid is operating.
- : check motor rotation direction.
- : check for air in system.
- : check for incorrect hydraulic connections.
- : check there is sufficient fluid in the system.
- : check that the flow control is open.
- : check that the relief is set correctly.
- : check the drive coupling between pump and motor.
- : check if the pump has been dismantled and incorrectly assembled.

3) Excessive noise

- : check for air in system.
- : check the motor for damage.

SERVICE

With a minimum of moving parts and top quality precision engineering the pump will give many years of trouble free service. Should service replacement seals be required, a kit is available from your nearest dealer under the following part code: PC45-sk

During disassembly carefully note the order of the components and keep everything scrupulously clean, especially the pump faces with the plastic shim gasket or o-ring. When re-assembling, lubricate the check valve piston and gears with hydraulic fluid and ensure that all parts move freely. A smear of grease on the o-rings will aid assembly without damage.

Evenly torque tighten the four M6 pump socket head cap screws to 10 lbs/ft (13.5 Nm). The gears must turn easily at this stage.

FILTERS

Constant running pumps are equipped with internal return-line filters which must be changed after the first 50 hours and then annually. Spare filters can be ordered under the part code: R2690

To access the filter first drain the tank then undo and remove the clamp ring. Carefully withdraw the tank taking great care not to distort the tank or damage the O ring seal or tank lip. The filter is secured with a single nylock nut. Once the filter is replaced tighten the nylock nut until the filter is secure then fit the new O ring and re-fit the tank. A smear of general purpose grease will aid assembly.

BRUSHES

Inspect the motor brushes every 500 hours, or annually, for wear. Replacement motor brushes are available from your dealer. State the serial number of your unit when ordering.

Be sure to clean out all loose carbon before fitting new brushes. If fluid has entered the motor, degrease the brush gear and commutator before running the unit, otherwise arcing will reduce brush life.

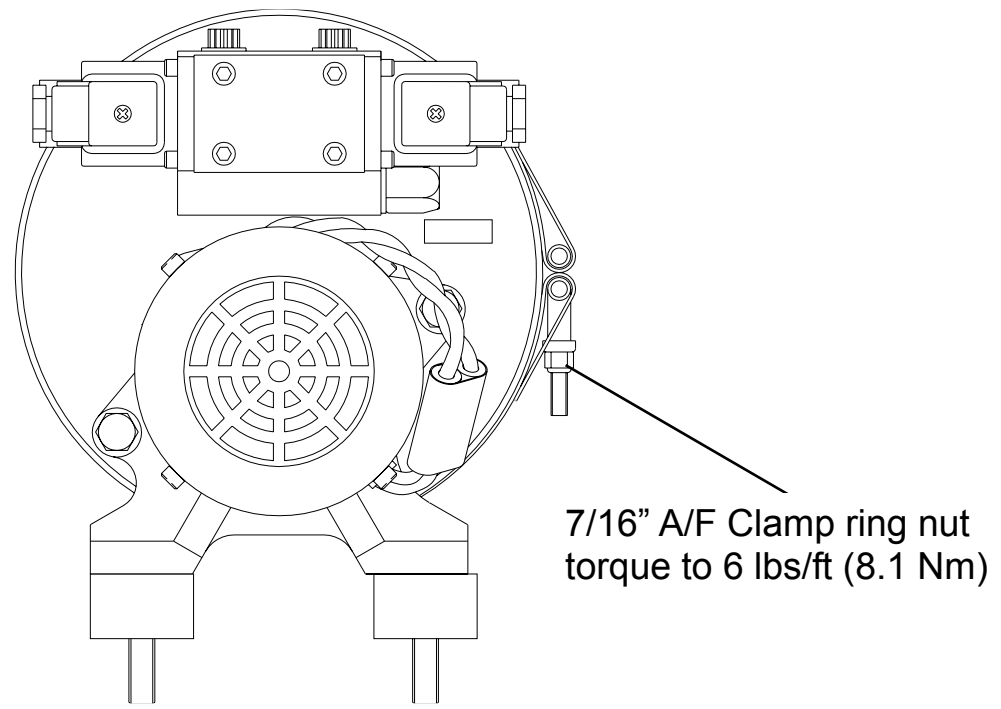
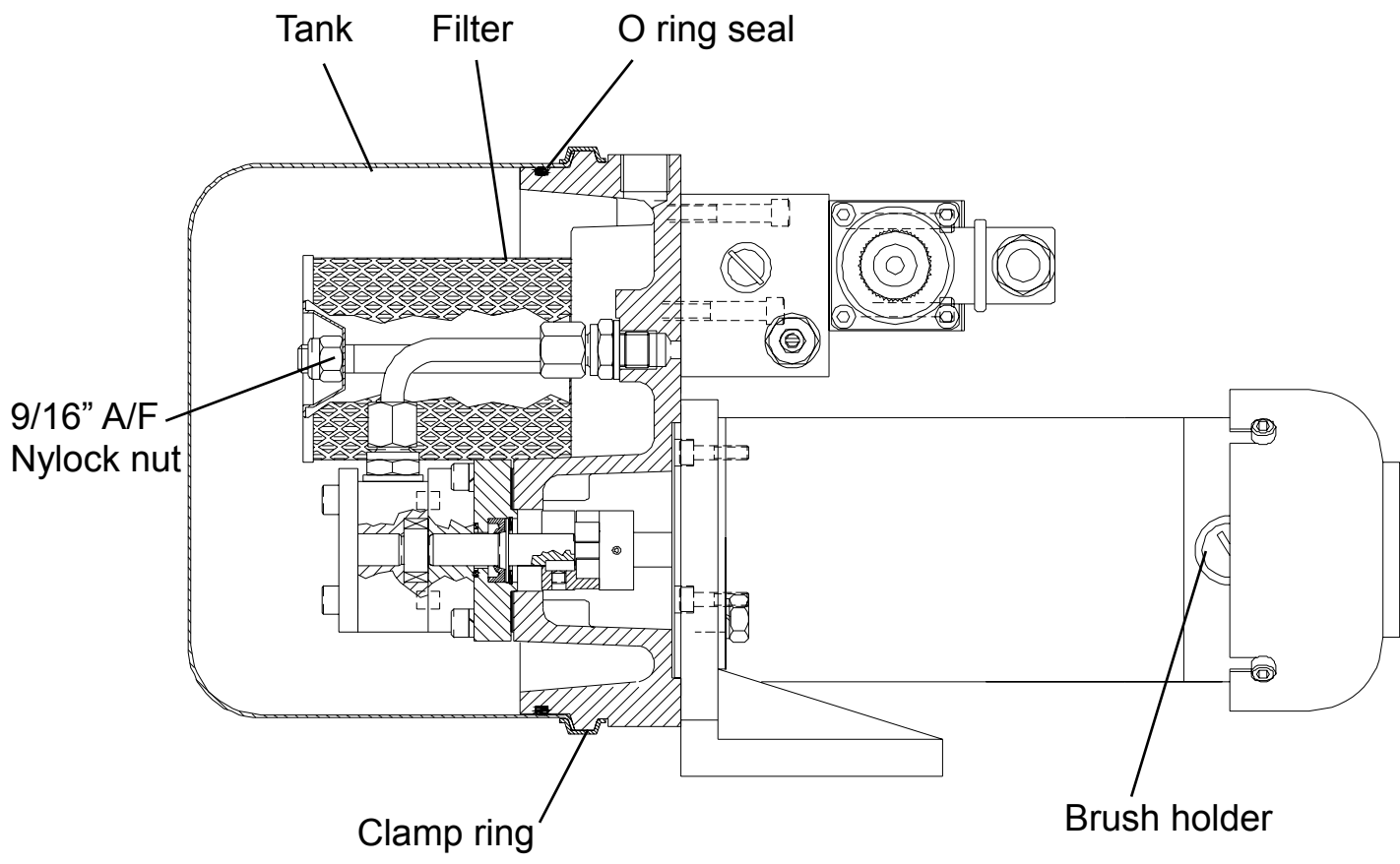

TECHNICAL DATA

Max Pressure: 70 Bar

Amb. Temp: -20 to +55 deg C
(ref. 'Recommended oils)

Supply Voltage: 12 / 24 VDC

Current Limitation: Must be fitted with current overload.
Minimum fuse/trip rating :
PC45 FCU 24 = 40A
PC45 FCU 12 = 50A

Performance: Refer to graphs

Installation: Under deck, horizontal or vertical
(tank down) Horizontal only if fitted
with isolation mounts.

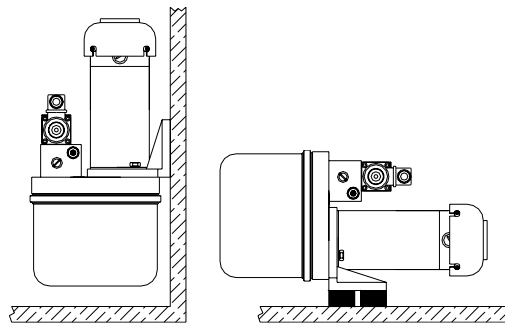

Pipework: Suitable for 70 Bar
working pressure (100 max)

Rec. Oils: From -20 to +10 deg C
use ISO VG10.
From +10 to +55 deg C
use ISO VG40

Filtration:	Replacable internal element. Return line 15 micron
Motor Rating: (PC45 FCU 24)	25% Duty Cycle: 30A 50% Duty Cycle: 25 A 100% Duty Cycle: 20 A 550W, IP54
Reservoir:	4.0 L Capacity 3.5 BAR Max.
Relief Valve:	Pre-set 57 Bar
Speed Control:	Screw in to reduce speed Adjustable Pressure compensated
Solenoid Coils:	12V 2.5A 24V 1.3A
Relay:	12V 1.0A 24V 0.5A
Reservoir Port 'R': Cylinder Ports 'A' & 'B':	G3/8 (BSP) Parallel G1/4 (BSP) Parallel
EMC Protection:	BS EN 60945:2002 (DC)
Ignition protection:	BS EN 28846:1993
Part Nos:	PC45 FCU 24 (550W) PC45 FCU 12 (405W)
Weight:	12kg

INSTALLATION DETAILS

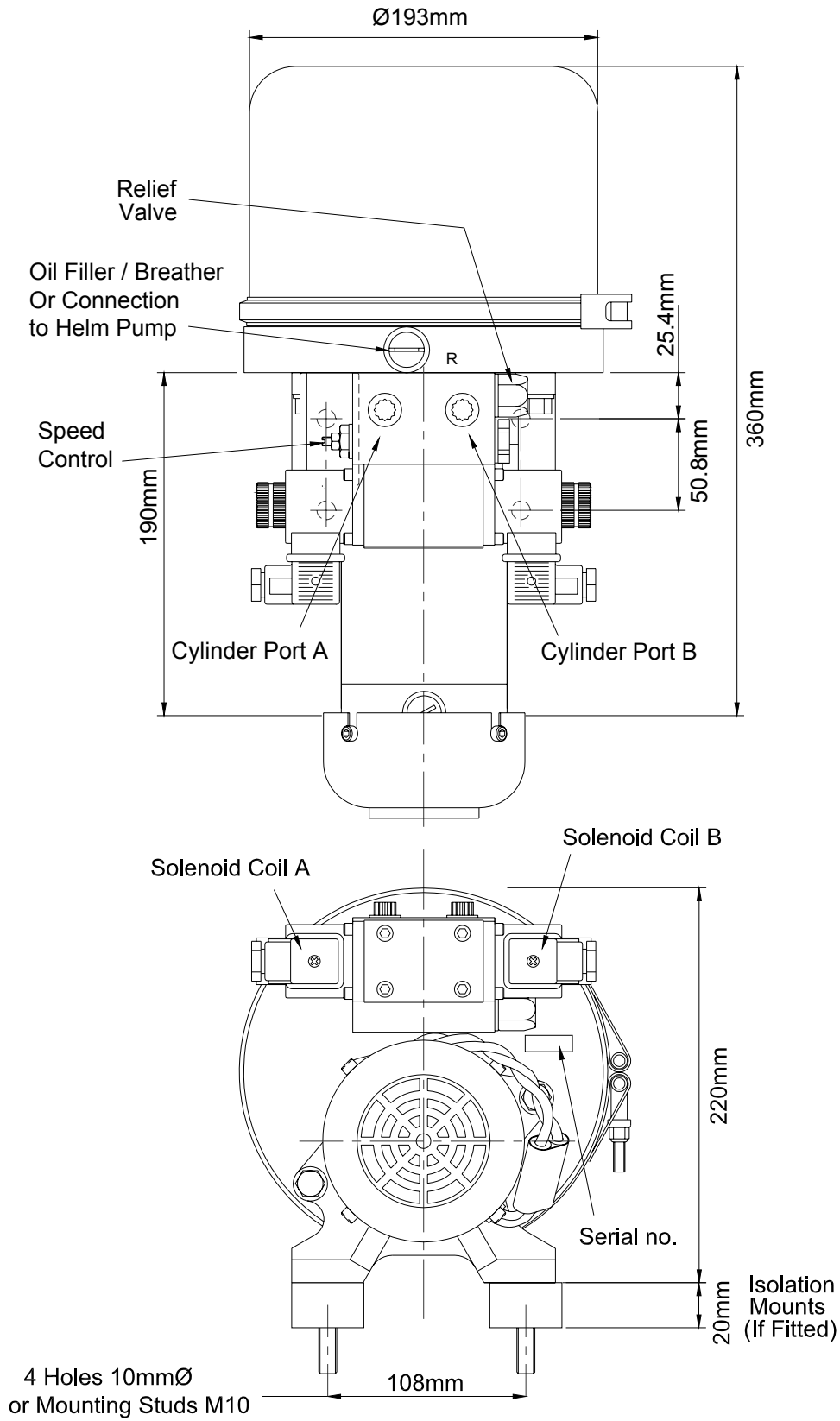

TYPICAL PERFORMANCE
(WITH FLOW CONTROL SET TO MAXIMUM)

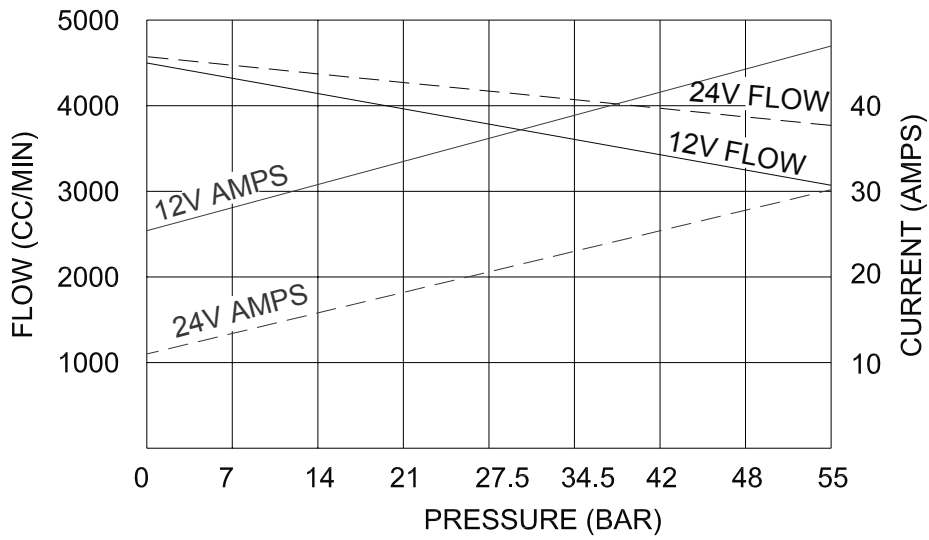

WIRING DETAILS

Autopilot
A & B - Course output
C - Pump engage (Clutch) output

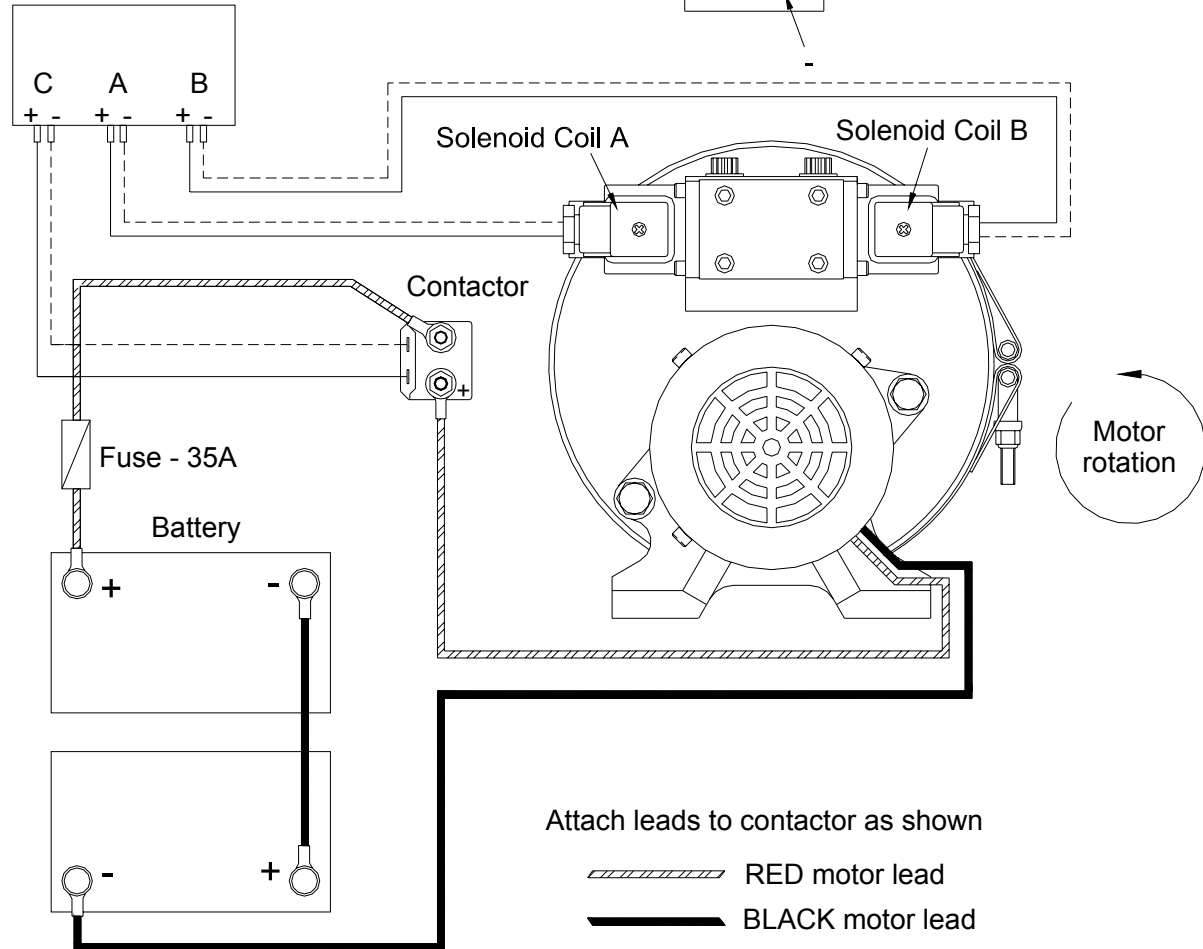
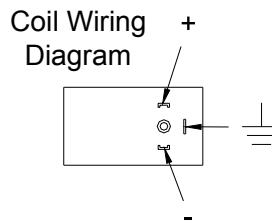

Use wire gauge - 2.5mm² Min

Attach leads to contactor as shown

- RED motor lead
- BLACK motor lead

TYPICAL ARRANGEMENTS

Primary Steering

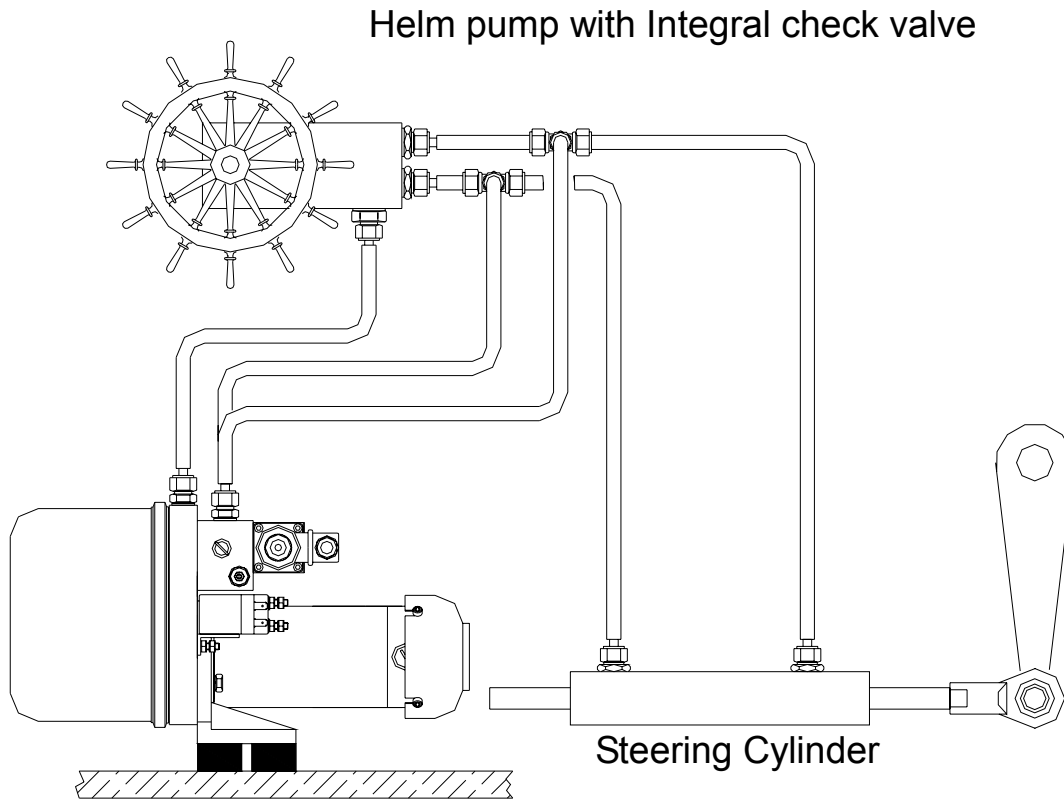

Secondary Steering

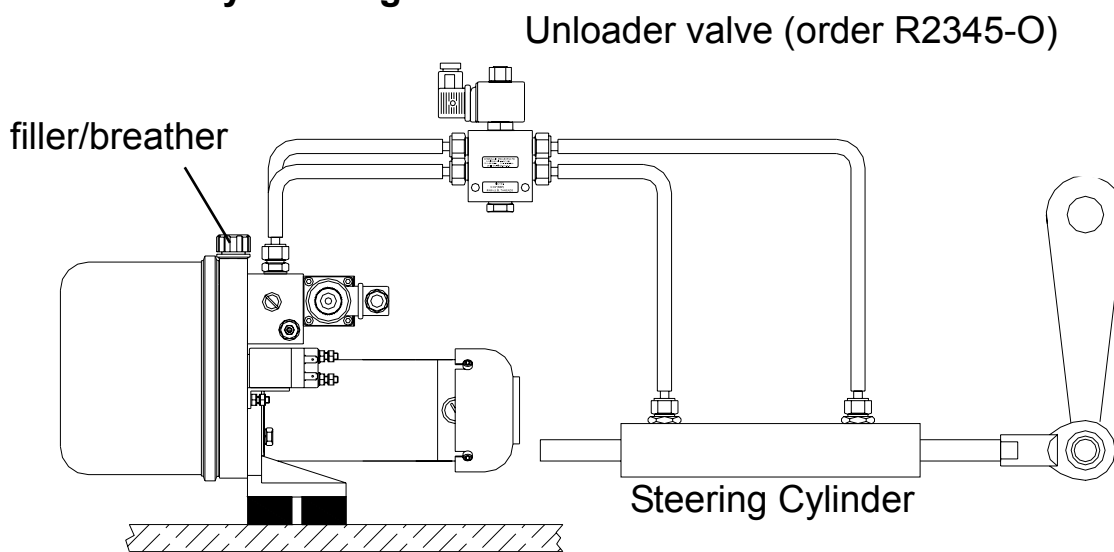

GENERAL INFORMATION

Keep this manual in safe place.

Quote the model and serial numbers in all correspondence.

Model Number: _____

Serial Number:: _____

Date of Purchase: _____

Dealer:: _____

END OF LIFE DISPOSAL

Please dispose of End of Life items responsibly.

In the event that you are unable to use your nearest local authority civic amenity sites to recycle, units can be returned to us at the address on the back cover.

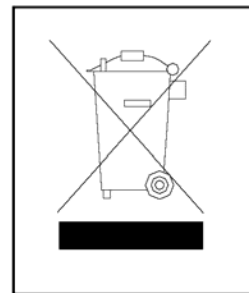

CONTACT DETAILS

Hydraulic Projects Limited

Dawlish Business Park

Dawlish

Devon

EX7 0NH

United Kingdom

Telephone +44 (0)1626 863634

Fax +44(0)1626 866283

Email sales@hypro.co.uk

Web www.hypro.co.uk