

Emergency Department

 **Herman Miller** for Healthcare

Graphic Standards
Programming and Schematic Design

June 1999

Table of Contents

Function	3	Functional Areas	8	Functional Program	24
		Patient Registration	8		
Staff	6	Triage	9	Bubble Diagram	25
Advantages of Movable Modular Casework	7	Fast Track Clinic	10	Block Diagram	26
		Nurses Station	11	Preliminary Plan	27
		Medication Preparation/ Nourishment Area	12	Schematic Plan	28
		Exam Room	13		
		Major Treatment/Trauma/Cardiac	14	Future Trends	29
		Cast Room	15		
		Observation/Holding	16		
		Equipment Storage	17		
		Clean Utility	18		
		Soiled Utility	19		
		Decontamination	20		
		Satellite Lab	21		
		Ambulance Personnel/Police	22		
		Family Counseling	22		
		Other Areas	23		

Function

The emergency department (ED), frequently referred to as the ER (emergency room), is responsible for the emergency treatment of all persons arriving at the emergency door, whether the care is required because of the effects of trauma, sudden illness, or “last resort” primary care.

Some large urban hospitals may have a separate pediatric emergency department as well as a “fast track” emergency medical clinic.

Patients may be admitted to the hospital from the ED or referred to an appropriate outpatient clinic, thereby reserving the ED for the treatment of true emergencies. The ED accounts for approximately 40 to 60 percent of all hospital admissions.

It is common for the patient census to fluctuate throughout a day. The ED may be quiet for hours at a time, then multiple emergencies can arrive for simultaneous treatment.

The design of the department must support the emergency treatment administered, allowing quick access of the staff to the patient at all times. Traffic flow of patients, staff, and supplies is critical and requires careful planning for efficiency and safety, with particular attention to the movement of patients requiring immediate or life-threatening care. All lifesaving equipment must be located where easily and quickly accessible.

The security of the staff, the patients, and the supplies also can be a key concern. Admittees to the ED may require attention aside from the medical/surgical treatment of their condition, such as the emotionally unstable, the chemically unstable, the criminal, and/or their victims. It is not uncommon for the police to be present in the ED.

Classifications of Emergency Departments

An emergency department is classified according to the service available ranging from a first aid/referral level to a comprehensive level of care. These levels of care are defined by the American College of Surgeons.

Level I

Level I offers comprehensive emergency care twenty-four hours a day, with at least one physician on duty who is experienced in emergency care. There is in-hospital coverage by members of the medical staff or by senior-level residents for medical, surgical, orthopedic, obstetric/gynecological, pediatric, and anesthesia services. Other specialty consultation is available within approximately thirty minutes. Hospitals offering these services are often referred to as regional trauma centers.

Level II

Level II offers emergency care twenty-four hours a day, with at least one physician experienced in emergency care on duty in the emergency care area, and with specialty consultation available within approximately thirty minutes.

Level III

Level III offers emergency care twenty-four hours a day, with at least one physician available to the emergency care within approximately thirty minutes through a medical staff call roster. Initial consultation over the phone with a physician is acceptable.

Level IV

Level IV offers reasonable care in determining whether an emergency exists, renders lifesaving first aid, and makes appropriate referrals to the nearest organizations capable of providing needed services.

Flow of Patients through an Emergency Department

The patient arrives at the ED either ambulatory and/or by private vehicle or by ambulance or helicopter. Separate entrances generally are provided for ambulatory patients and those arriving by ambulance or helicopter. The patient may arrive with or without prior notification of arrival.

A triage, or evaluation area, is provided to allow assessment of the patient's condition and degree of urgency. If immediate care is necessary, the patient will be taken directly to the appropriate exam or treatment area.

Patients arriving by ambulance or helicopter, usually in need of immediate treatment, are moved to a major trauma room.

Noncritical injuries or illnesses will be registered and treated as quickly as is appropriate to the census of the patients in the ED.

A waiting/reception area is usually located outside of the emergency department, accessible to the walk-in entrance.

Families will wait in this reception area, or a secluded family counseling room may be provided.

Patients are either discharged from the ED, admitted to the hospital as inpatients, or transferred to another facility.

Staff

The emergency department staff routinely makes multiple, rapid treatment decisions regarding critically ill patients. The work environment can be intense and stressful. The staff consists of highly skilled professionals trained to cope with a variety of accidents, injuries, and patient ages – from newborns to the elderly.

Physician Staff

Physicians

The physician coverage consists of the ED physician. Because of the complexity of treatments, there may be many specialized consulting physicians, (e.g., a neurologist) and a medical director assigned to the department to oversee the practices of the department.

Nursing Staff

Nurse Manager

The nurse manager, sometimes called head nurse or nursing care coordinator, is a professional registered nurse (RN), often with advanced education, training, and experience in emergency and trauma nursing. This position is responsible for the management of the entire department, including the standards of patient care, capabilities of the nursing staff, and consultation and interface with the medical staff on patient care problems.

Assistant Nurse Manager/Charge Nurse

The charge nurse is a professional registered nurse (RN), usually with additional training and experience, and is the primary resource or management staff on a particular work shift. The responsibilities of the charge nurse are similar to those of the nurse manager for day-to-day operations.

Staff Nurse

The staff nurse is a registered nurse (RN) with the primary responsibility for the total management of the patient's care, or a portion of that care, and the evaluation of the patient's condition and responses to treatments.

Licensed Vocational Nurse

Licensed vocational nurses (LVN), licensed practical nurses (LPN), or patient care assistants, having less skilled training and education than RNs, are responsible for only those duties appropriate to their experience. Patient care is supervised by the RN.

Support Staff

Unit Secretary/Clerk

Clerical staff within the emergency department perform such tasks as receptionist, physician order entry, filing of reports, telephone communication, and coordinating administrative activities.

Support Staff

A variety of other ancillary staff may have limited functions in the emergency department, such as IV therapists, phlebotomists, respiratory therapists, pharmacists, and emergency medical technicians (EMTs).

Advantages of Movable Modular Casework

Hospital emergency departments may differ somewhat in square footage, method of operation, and staffing based on the size of the hospital, type of hospital, and scope of services, but each hospital emergency department has certain functional areas in common. The following pages describe the advantages of movable modular casework, give a brief description of the functional areas of emergency departments, and provide typical plan views of movable modular casework applications.

Movable Modular Casework

The emergency department is a highly intense and stressful environment. The staff must respond to constantly changing and unpredictable types of emergencies. Fixed construction does not respond to this type of changing environment and technology.

Movable modular casework offers the following major advantages and differences when compared with fixed casework or millwork:

- *All* movable modular components can be easily rearranged or reused by the end user, allowing for changes in procedures and technologies.
- Configurations can be disassembled to allow easy and repeated sanitization both of work surfaces and storage components.
- Because of the density of supply storage, movable modular casework components require less square footage within an emergency department.
- Additional components can be added at any time.

Materials Handling Components

Movable modular materials handling components can be especially useful in the emergency department for supporting efficient delivery, storage, use, and removal of supplies needed for the emergency procedures.

Movable modular casework components have been designed as a movable system allowing the ED staff to move all necessary supplies to the emergency patient utilizing a variety of carts:

- Procedure/supply carts.
- Crash carts.
- Technology carts.
- Wire carts.
- Mobile tables.

Financial Advantages

The initial cost of movable modular casework is competitive with fixed casework or millwork. However, the life cycle cost of movable modular casework is far *less* than fixed casework because of

- Longer product life.
- Minimal maintenance cost.
- Continual reuse of the components for new or different functions.
- Ability to install and reconfigure with little downtime.
- Accelerated depreciation rate, especially important to “for-profit” organizations.

For preliminary budget purposes, movable modular casework for an emergency department has an average price in the range of \$331 to \$496 per linear foot.

This range will be affected by the density of overhead and undercounter storage components and the type of support structure used (wall-mounted versus panels).

Functional Areas **Patient Registration**

In planning patient registration areas in the emergency department, consideration must be given to the level of security needed based on the location and size of the hospital. Urban hospitals may require extensive security measures; whereas, suburban or rural hospitals may want to convey a more hospitable image.

The ED may require payment from patients at the time services are rendered in the department. A clerical area similar to admissions is provided where the patient (or visitor) completes necessary paperwork. This area should meet ADA (Americans with Disabilities Act) standards and allow the patient sufficient wheelchair room.

Movable Modular Casework Applications

Movable modular casework utilizing freestanding panels or frames is the application of choice and will provide

- Maximum space utilization.
- Integration of computer technology.

Movable modular casework components may include

- Cantilevered work surfaces.
- Transactional work surfaces.
- Overhead storage.
- Computer tools and keyboard trays.
- Task lighting.

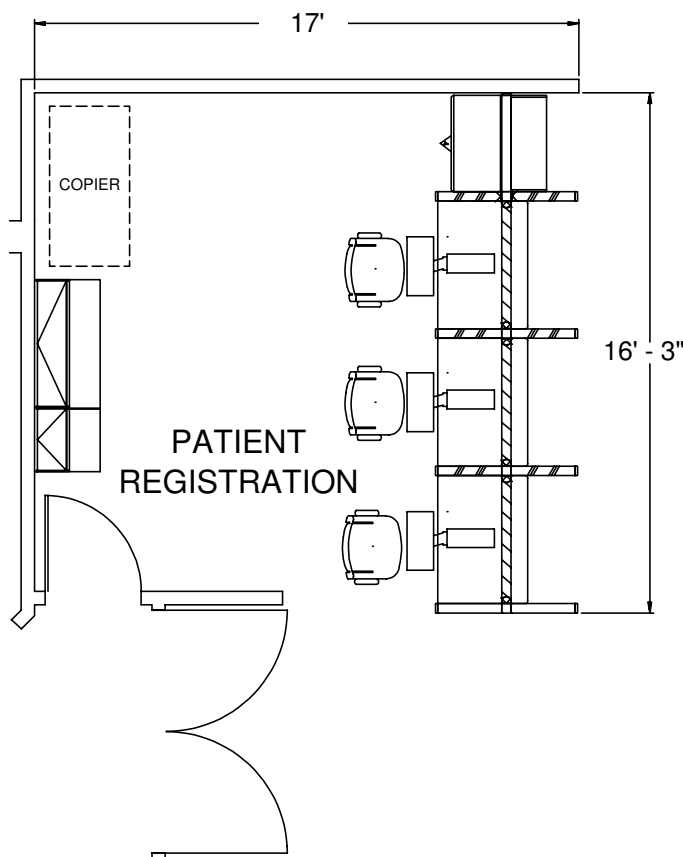
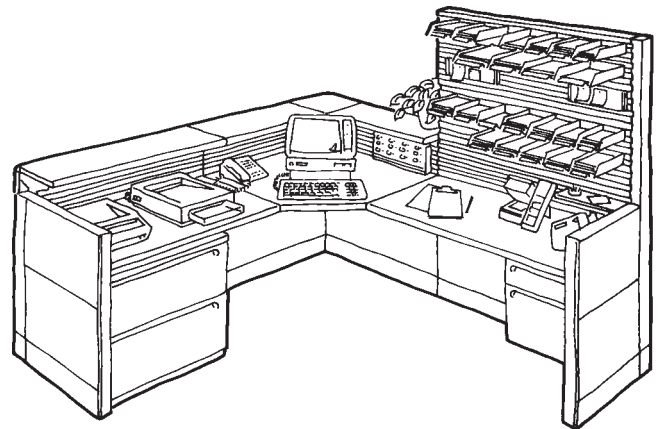

Plan View of a Patient Registration Area

A patient registration area will range in size from 100 to 400 square feet.

- 18 linear feet work surface
- 24 linear feet overhead storage
- 224 filing inches
- 276 square feet

Triage

Patients who enter the ED through the ambulatory entrance are evaluated at triage. A preliminary history is taken to determine the level of care needed.

The triage is located adjacent to the admitting/waiting area.

A wheelchair and/or stretcher may be stored in this area.

Movable Modular Casework Applications

Movable modular casework components used in a triage area are similar to those used in an exam rooms and may include

- Small administrative area for the triage nurse.
- L cart with modular drawers for a limited amount of supplies.
- Locker with drawers and shelves.
- Cantilevered work surfaces.
- Overhead storage.
- Cantilevered sink unit.

Plan View of a Triage Area

A triage area will range in size from 150 to 300 square feet.

- 10 linear feet work surface
- 18 linear feet overhead storage
- 20 filing inches
- 1 procedure cart
- 150 square feet

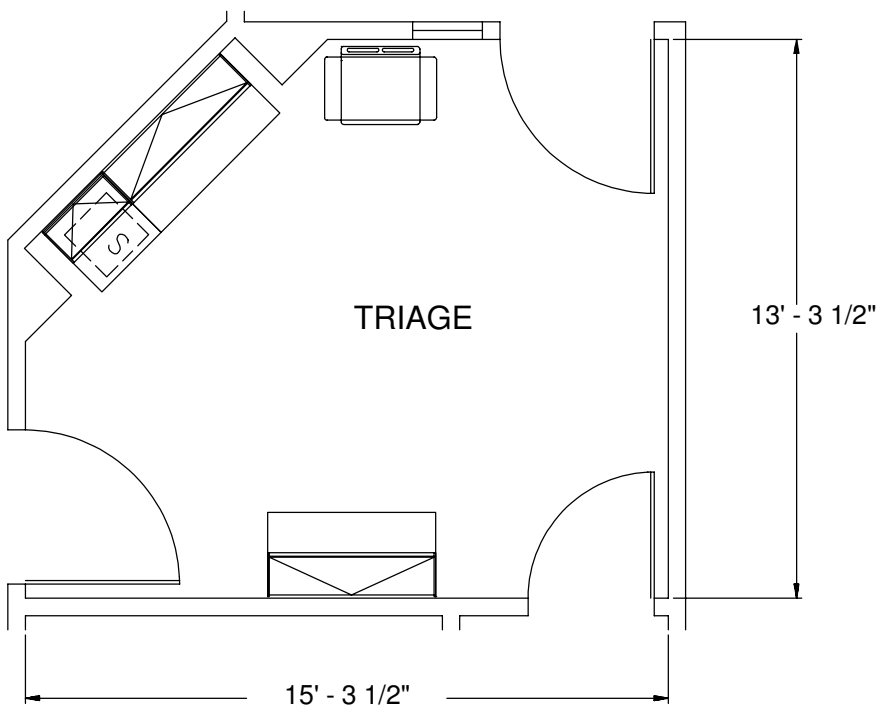

Fast Track Clinic

In order to compete with the surge of freestanding emergency medical centers, many hospitals are incorporating into their emergency department a “fast track” emergency clinic. This clinic will handle minor illnesses and injuries such as colds, sore throats, puncture wounds, cuts, and abrasions. The goal of the clinic is to treat and release patients in less than an hour.

Hospitals also are marketing this service to local industries for workers’ compensation patients, pre-employment physical examinations, and drug screening.

The clinic may have a separate staff including a physician, physician’s assistant, nurse clinician, and at least one other nursing staff position, such as a registered nurse (RN) or licensed practical nurse (LPN). It also may have its own waiting and registration area, although it is generally located near the waiting area and triage room of the emergency department.

Movable Modular Casework Applications

Movable modular casework components can be used in the fast track clinic for treatment rooms, work areas, and storage and may include

- Cantilevered work surfaces at stand-up height with drawers.
- Overhead storage, regular or extra-deep modular shelving units.
- Lockers.
- L carts or procedure/supply carts for transporting supplies.
- Cantilevered sink unit.

Plan View of a Fast Track Clinic

A fast track clinic will range in size from 150 to 400 square feet.

- 6 linear feet work surface
- 6 linear feet overhead storage
- 1 locker for medical supplies
- 1 procedure cart
- 225 square feet

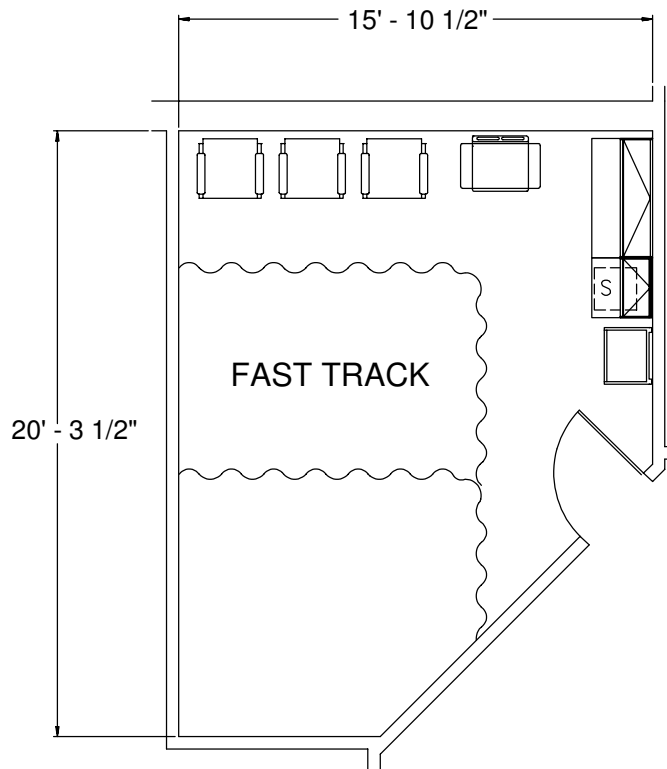

Nurses Station

The size and acuity level of the emergency department will affect the size and layout of the nurses station. Larger Level I and II departments may have one main station and smaller stations located closer to patient care areas. Some emergency departments will have only one nurses station.

The nurses station in an emergency department is a very active area occupied by many different staff members. It is critical to support the staffs' ability to respond efficiently to emergencies by providing separate work zones to control traffic.

Plan View of a Nurses Station

A nurses station will range in size from 250 to 600 square feet.

52 linear feet work surface	2 procedure/supply carts as crash carts
12 linear feet overhead storage	
165 filing inches	374 square feet

Charting/Dictation Area

A stand-up or sit-down area should be provided for preparing patient charts and recording patient treatments. It also may include an area for doctors' dictation.

Central Monitoring Area

Space may be required for a central monitoring system.

Radio Control Area

A room or space is provided where doctors and nurses may communicate with helicopter/ambulance personnel via radio. This may be part of the nurses station or a separate room. There also may be a need to record information regarding the patient and instructions given regarding the care of the patient while en route to the ED.

Movable Modular Casework Applications

The entire nurses station can be planned using freestanding modular components. The use of a panel or frame system provides the following:

- Maximum utilization of space.
- Continual integration of computer technology, such as a central monitoring system.
- Overhead storage for manuals and technical reference materials above work surface counter or transactional work surface.
- Procedure/supply carts as crash carts.
- Task lighting.
- Electrical capabilities for continual integration of phones, fax, radio, copiers, printers, emergency power, etc.

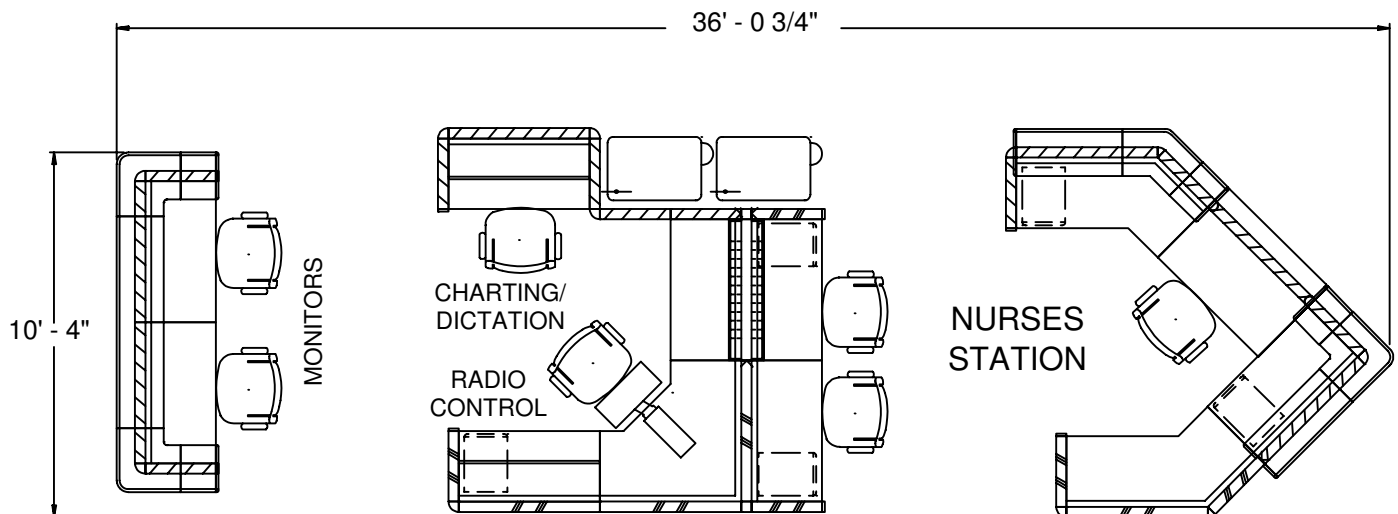

**Medication Preparation/
 Nourishment Area**

A medication preparation area will be stocked with various medications needed for use in a wide variety of emergency illnesses and traumas.

The security of medications is more critical because of the number of visitors and patients in the ED and the large amount of controlled drugs; therefore, the medication area is frequently placed within the nurses station or as a separate secured room.

The medication preparation area will require a sink unit and a refrigerator, as well as medication labeling/dispensing capabilities to allow patients to take medication home if the hospital pharmacy does not provide this service during all hours.

A separate refrigerator is required for nourishment items.

Movable Modular Casework Applications

Movable modular components used for medication dispensing include lockers, medication cassettes and carts, cantilevered work surfaces, and cantilevered sink units.

Medications and IVs can be stored in lockers with cassettes, drawers, or shelves on a replenishment exchange system with the pharmacy. Narcotics and controlled substances can be stored in double-locking drawers.

Storage space is required for cups, condiments, etc. These may be stored in drawers, lockers, overhead storage, or base cabinets.

***Plan View of a Medication
 Preparation/Nourishment Area***

A medication preparation/nourishment area will range in size from 50 to 150 square feet.

- 10 linear feet work surface
- 10 linear feet overhead storage
- 2 lockers
- 50 square feet

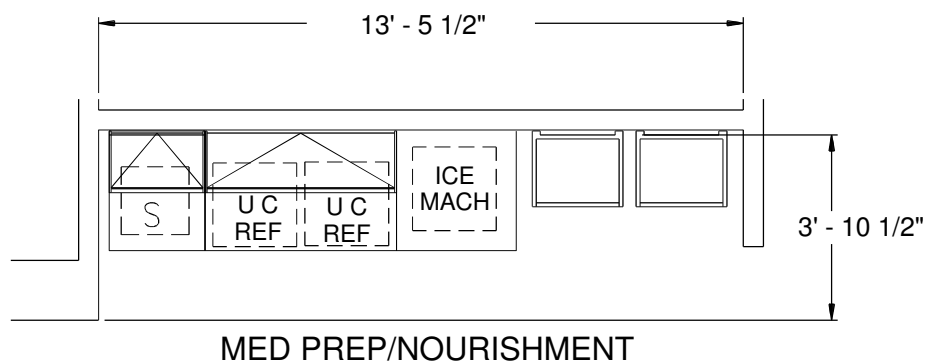

Exam Room

A smaller room, usually with a single stretcher or exam table, is used for simpler procedures. These may be general rooms with standardized equipment and supplies, or they may be designated as specialty rooms with specialty equipment and supplies.

The most common specialty exam rooms are for pediatrics, gynecology, eye/ENT (ear, nose, and throat), and isolation/psychiatric patients.

The exam room that is used for isolation/psychiatric patients also may be used for prisoners being held by the police. For security, only mobile carts should be used in the exam room designated for psychiatric/criminal patients.

An alternative to specialty exam rooms is the use of procedure carts that can be moved to generic exam rooms for a specific case.

Patients may wait unattended in these rooms for extended periods; therefore, supply storage is limited and may be locked to control pilferage.

Exam rooms will have a hand-washing sink.

Plan View of an Exam Room

An exam room will range in size from 80 to 150 square feet.

- 4 linear feet work surface
- 4 linear feet overhead storage
- 1 procedure cart
- 1 locker for specialty supplies (optional)
- 140 square feet

Movable Modular Casework Applications

Movable modular components are applicable in exam rooms and may include

- Cantilevered work surfaces.
- Cantilevered sink units.
- Overhead storage.
- L carts and lockers for supplies.
- Modular carts developed as specialty procedure carts for generic exam rooms.

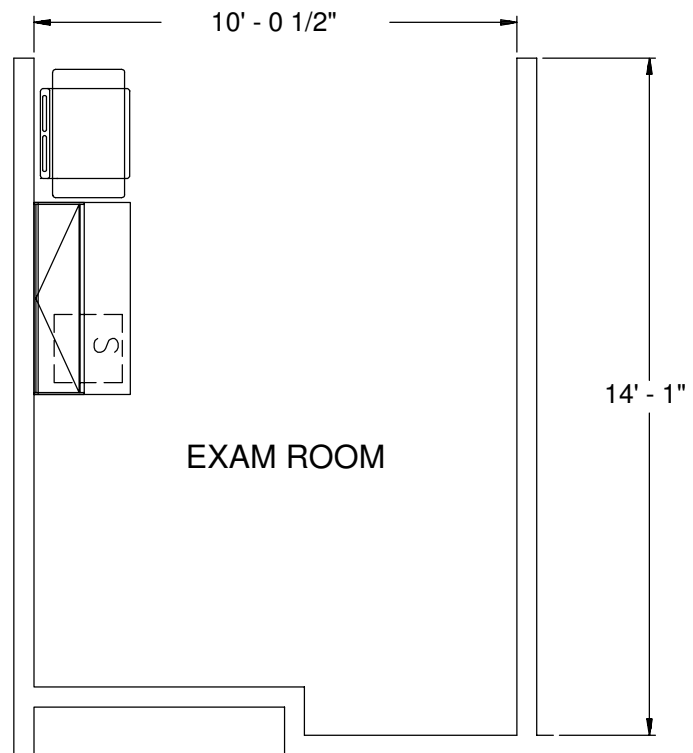
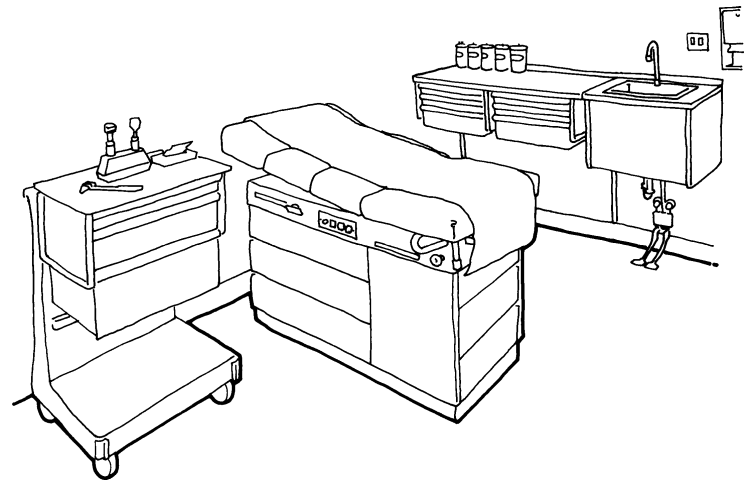

Major Treatment/Trauma/Cardiac

A large treatment area may house several stretchers and provide sufficient room so that a large number of staff and supplies can be positioned around a patient in a life-threatening situation.

This area also must have the ability to quickly accommodate additional patients.

Trauma rooms are positioned for clear observation by the nurses station.

This area may be supplied with items to treat specific emergencies. Supplies needed for unique emergencies are often held in procedure carts inside the room and wheeled to the patient as needed.

Sinks in this area should be provided with a foot pedal or wrist blades.

Movable Modular Casework Applications

Movable modular casework components are used effectively in trauma rooms and cardiac rooms and may include

- Cantilevered work surfaces.
- Overhead storage.
- Cantilevered sink unit.
- Mobile process table used as a workstation and providing storage.
- Lockers and/or bulk supply carts for a large number of supplies.
- Variety of modular carts, crash carts, procedure carts, and specialty carts.

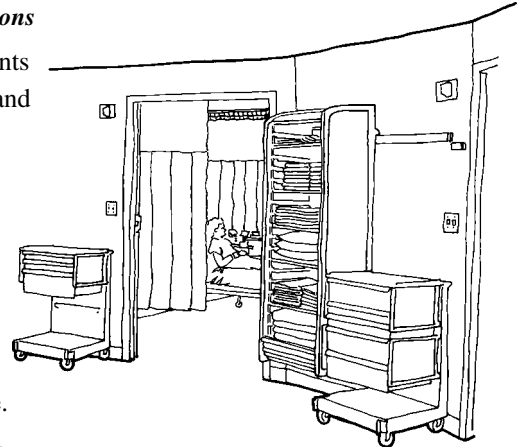

Plan View of a Major Treatment/Trauma/Cardiac Area

A major treatment/trauma/cardiac area will range in size from 400 to 1000 square feet.

- 14 linear feet work surface
- 6 linear feet overhead storage
- 4 procedure carts
- 6 lockers for medical supplies
- 506 square feet

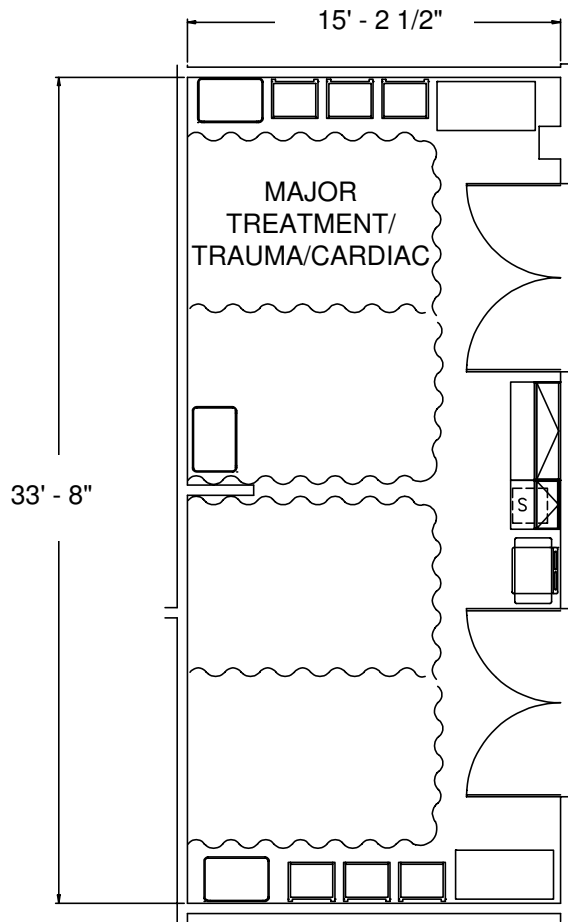

Cast Room

The ED usually has a separate room for applying orthopedic casts. This room may have a storage room for plaster, cast material, and other orthopedic equipment.

The room may have a special sink with a plaster trap.

Movable Modular Casework Applications

Movable modular components are used for work areas and storage of plaster cast materials and may include

- Cantilevered work surfaces for work areas.
- Mobile carts for cast supplies and procedure carts.
- Mobile table moved to the cast table.
- Lockers, extra-deep modular shelving units, or bulk supply carts for storing additional supplies.

Plan View of a Cast Room

A cast room will range in size from 120 to 300 square feet.

- 6 linear feet work surface
- 26 linear feet overhead storage
- 3 lockers for orthopedic supplies
- 1 plaster cart
- 270 square feet

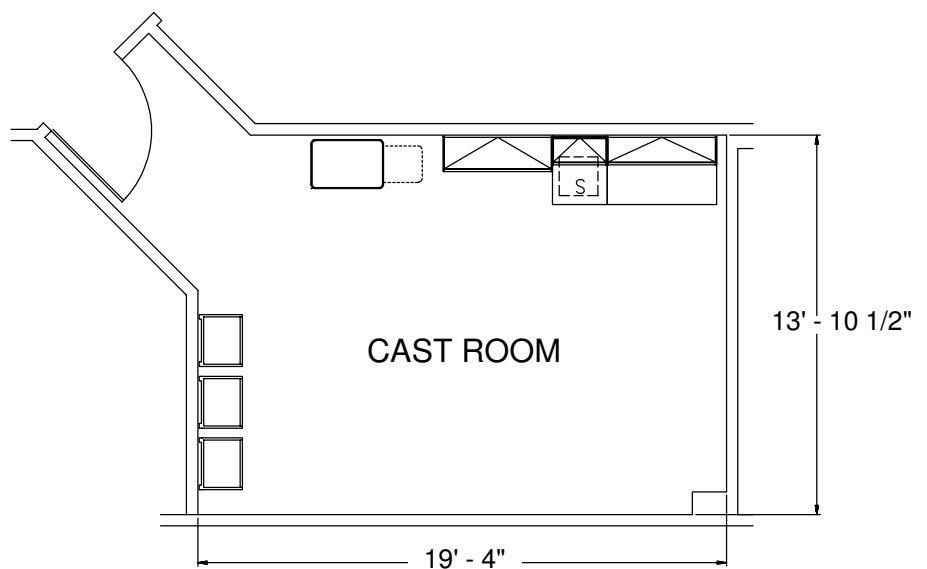

Observation/Holding

This area will be located within view of a nurses station. Patients who have received treatment but may require further observation wait on stretchers and are observed here before being discharged. This room also may be used as a holding area for patients waiting to be admitted.



Movable Modular Casework Applications

Movable modular components can be used to plan this area and may include

- A combination of wall-hung and freestanding mobile carts.
- Cantilevered work surfaces.
- Overhead storage for supplies.
- L carts with modular components for each observation area.
- Rail-hung C frame storage unit with drawers next to each stretcher.
- Cantilevered sink unit.

Plan View of an Observation/Holding Area

An observation/holding area will range in size from 250 to 450 square feet.

- 6 linear feet work surface
- 6 linear feet overhead storage
- 1 locker for linen storage
- 1 C frame storage unit per bed
- 407 square feet

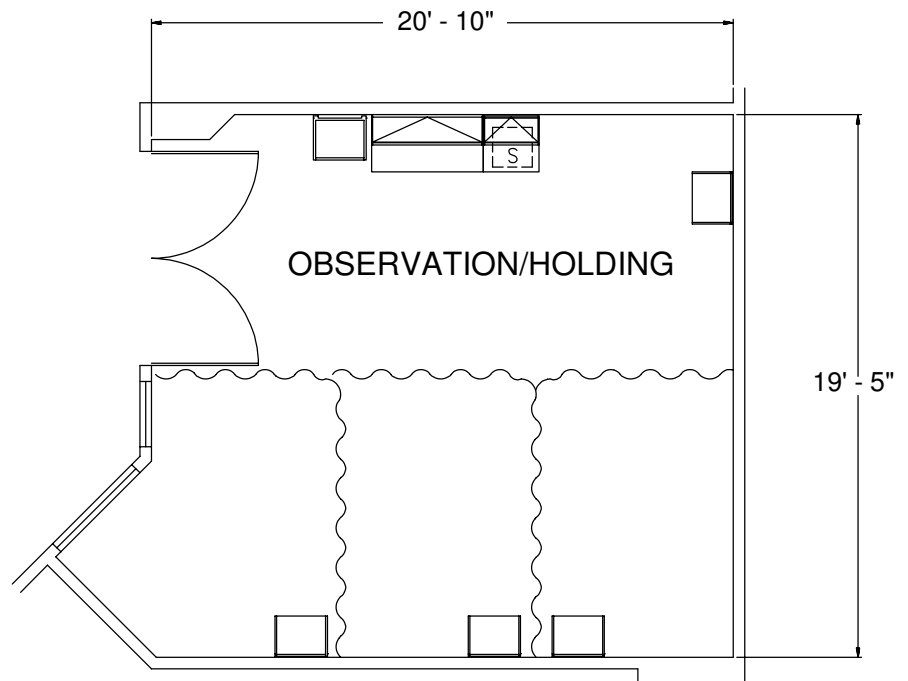

Equipment Storage

An equipment storage room may be large to hold wheelchairs, stretchers, lights, ventilators, and other emergency equipment.

Outlet strips to plug rechargeable equipment generally run the length of the room.

Movable Modular Casework Applications

Movable modular casework components can be used to plan this area and may include

- Lockers for small equipment such as batteries, cables, bulbs, etc.
- Extra-deep modular shelving units for small equipment.
- Wire cart to hold equipment that needs to be recharged.

Plan View of an Equipment Storage Room

An equipment storage room will range in size from 250 to 600 square feet.

- 16 linear feet storage
- 1-2 lockers for small equipment
- 1 wire cart for equipment being recharged
- 459 square feet

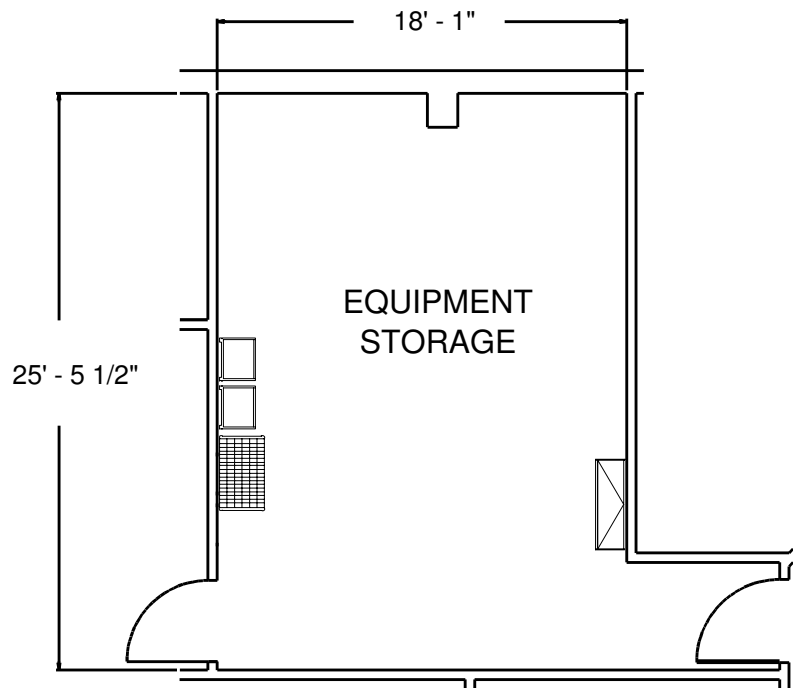

Clean Utility

The clean utility room will be larger than in normal patient units because of the need for a large quantity and variety of supplies.

The room may also house specialty procedure carts and will require space for restocking them. Depending on local codes, this room also may require a sink unit.



Movable Modular Casework Applications

Movable modular casework components can be used to plan this area and may include

- Modular carts for specialty procedure carts.
- Cantilevered work surfaces.
- Extra-deep modular shelving units.
- Mobile process tables, procedure/supply carts, and bulk supply carts.
- Cantilevered sink unit.

Plan View of a Clean Utility Room

A clean utility room will range in size from 150 to 300 square feet.

- 6 linear feet work surface
- 10 linear feet overhead storage
- 4 lockers for medical supplies
- 1 bulk supply cart
- 231 square feet

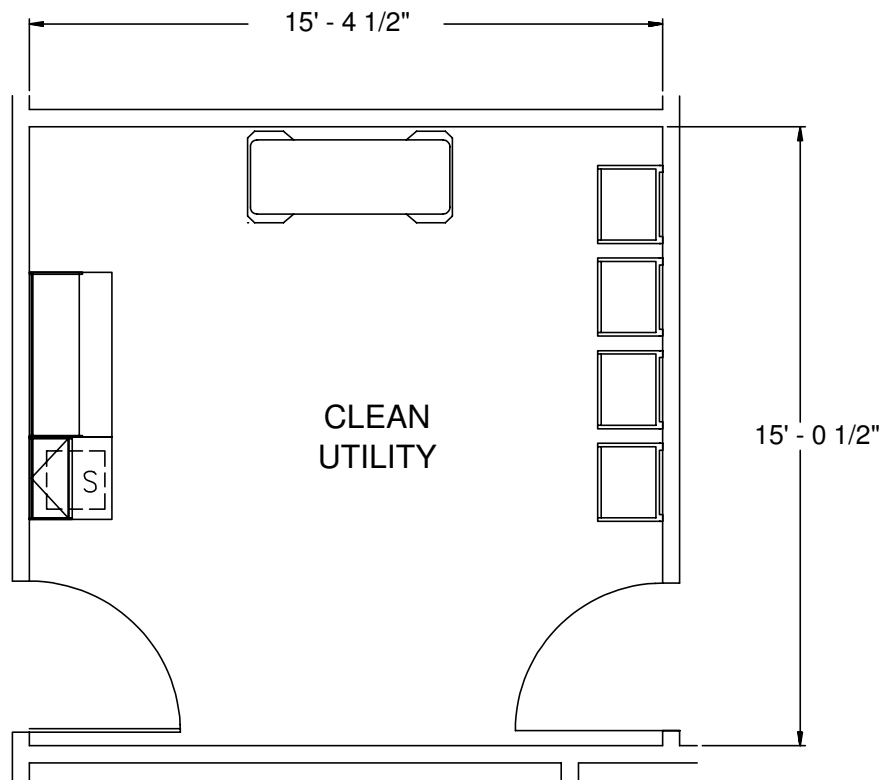

Soiled Utility

The soiled utility room houses the soiled linen and used equipment and supplies awaiting collection for disposal or reprocessing. This room typically has a sink and a flushing-rim sink.

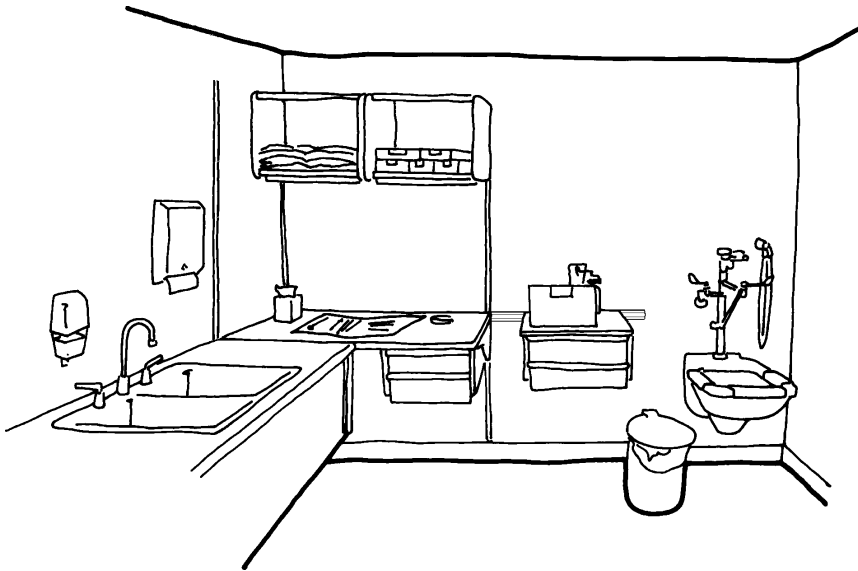

Movable Modular Casework Applications

Movable modular components can be used for work areas and overhead storage including

- Cantilevered work surfaces with drawers.
- Cantilevered sink unit.
- CST frame storage units or extra-deep modular shelving units for overhead storage.

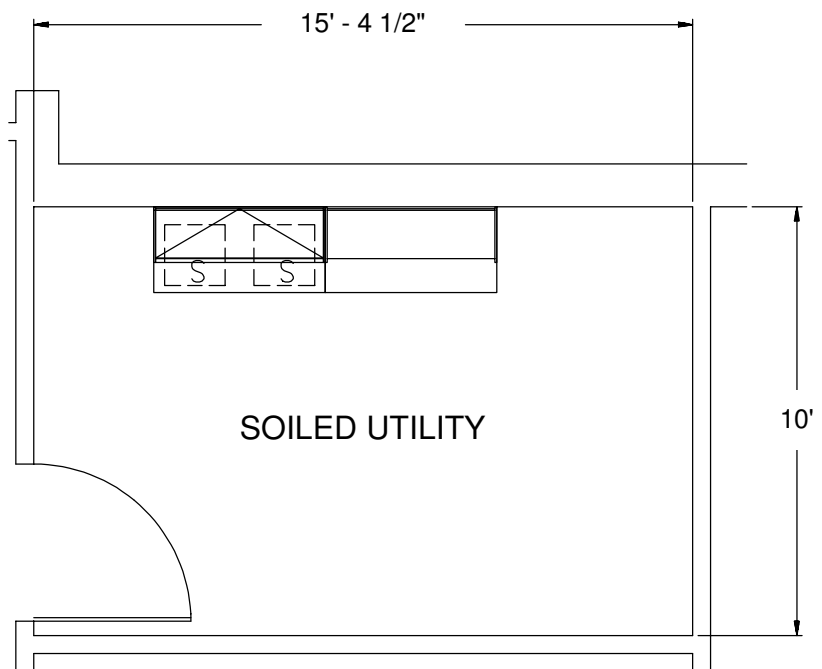

Plan View of a Soiled Utility Room

A soiled utility room will range in size from 120 to 200 square feet.

- 8 linear feet work surface
- 12 linear feet overhead storage
- 1 locker for soiled holding
- 155 square feet

Decontamination

This area is generally located near the ambulance entrance. It is a tiled shower area used to decontaminate patients exposed to chemicals, pesticides, or radiation. It may also be used to take care of the hygienic needs of some patients.

Movable Modular Casework Applications

Movable modular casework components can be used to plan this area and should include only mobile components:

- L carts.
- Lockers on TR3 carts or wheel base.
- Bulk supply carts.

Plan View of a Decontamination Area

A decontamination area will range in size from 120 to 250 square feet.

- 1 locker on TR3 cart or wheel base
- 215 square feet

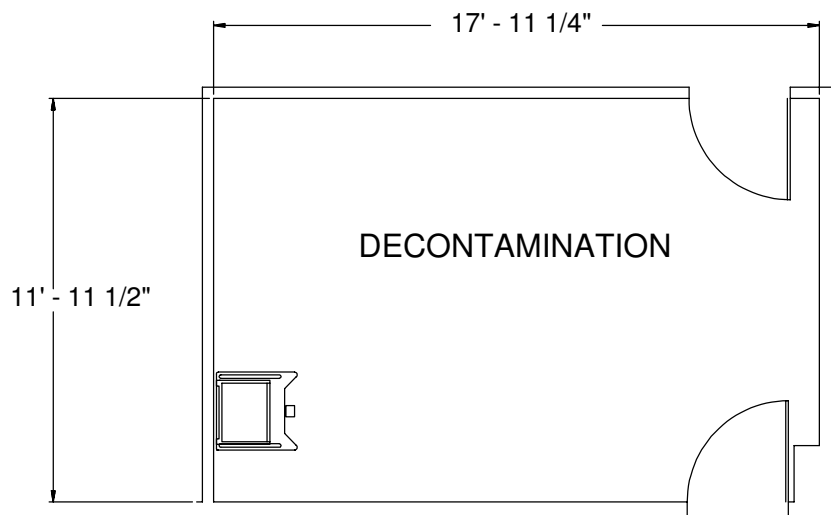

Satellite Lab

Satellite labs, also referred to as “stat” labs, make it possible to decentralize a lab’s services to respond quickly to a department’s specific needs. These labs will usually have “mini” versions of the chemistry, hematology, and urinalysis areas found in the primary lab.

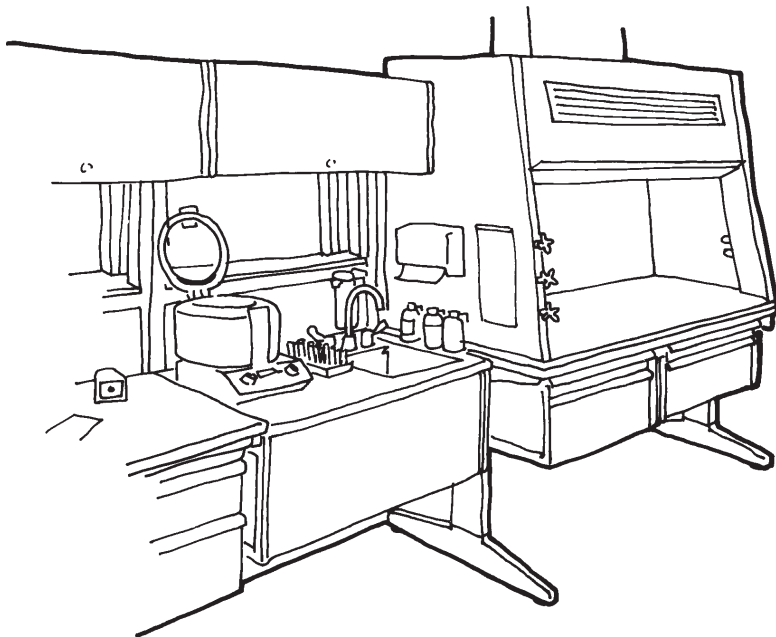

Movable Modular Casework Applications

Work areas can be different configurations based on the size of the emergency department and generally require

- Stand-up and sit-down work surfaces for specimen preparation.
- Heavy-duty work surfaces and/or process tables for automated instruments.
- Process tables at seated height for microscope use.
- Overhead shelving for reagents and manuals.

Plan View of a Satellite Lab

A satellite lab will range in size from 60 to 200 square feet.

- 8 linear feet work surface
- 10 linear feet overhead storage
- 60 square feet

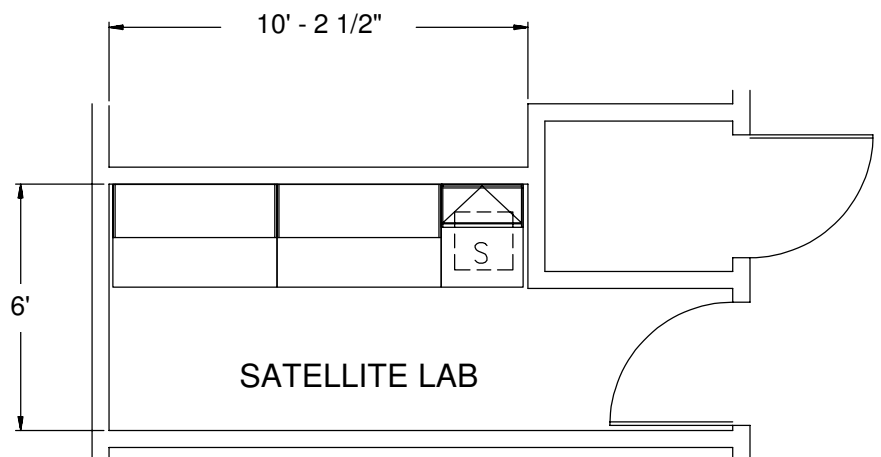

Ambulance Personnel/Police

An area may be provided for ambulance personnel or police and may include an area to store medical supplies to restock the ambulances. This area allows EMTs and police to complete their reports without using valuable space at the nurses station.

Movable Modular Casework and Furniture Systems Applications

Movable modular casework components and modular furniture systems can be used to plan this area and may include

- Cantilevered work surfaces.
- Lockers and extra-deep modular shelving units for medical supplies.
- Overhead shelving units which are wall mounted to accommodate necessary supplies, manuals, etc.

Plan View of an Area for Ambulance Personnel and Police

An area for ambulance personnel and police will range in size from 120 to 200 square feet.

- 8 linear feet work surface
- 32 linear feet overhead storage
- 2 lockers for supplies to restock ambulance tackboard/marker board
- 159 square feet

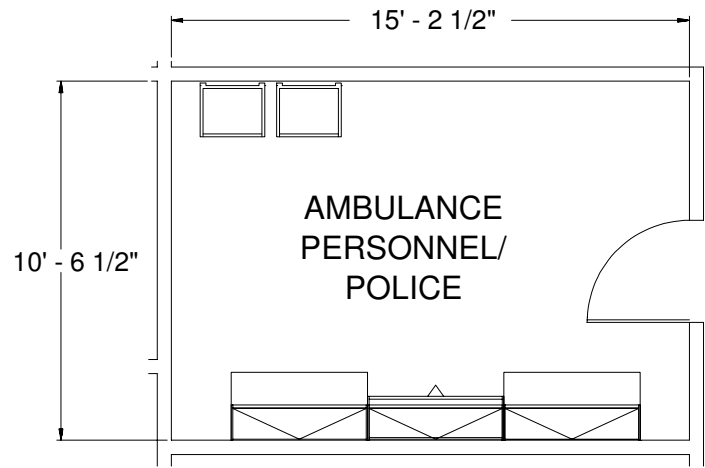

Family Counseling

A room is often located in the ED where physicians and social workers can meet privately with family members to discuss the patient's condition.

Movable Modular Casework and Furniture Systems Applications

Modular furniture systems can be used to plan this room and may include

- Comfortable seating.
- Small table.

Plan View of a Family Counseling Room

A family counseling room will range in size from 100 to 200 square feet.

116 square feet

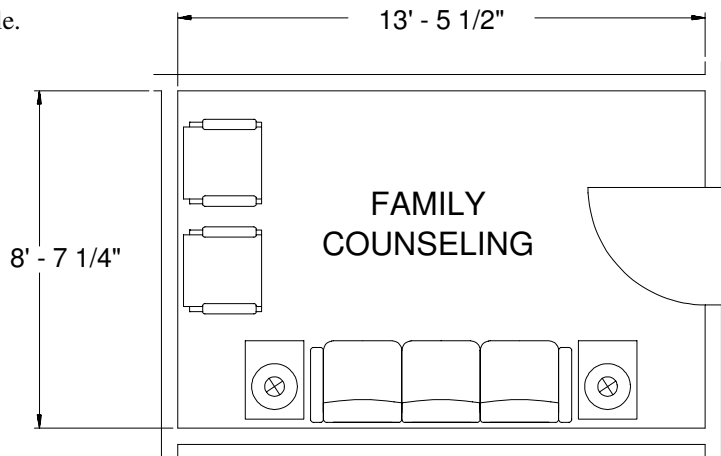

Other Areas

Waiting Room

Many different people use this space, twenty-four hours a day, and the size will depend on the size and level of the ED. Concerned visitors may be under stress while waiting for news of a patient. Patients wait here for treatment, and seating should be durable but comfortable.

Staff Lounge/Locker Room

Staff lounge space is provided for the ED staff to take work breaks without leaving the department.

Sleep Room or On-Call Room

Because lifesaving emergencies often depend on moments of time, physicians often will sleep in the department to save as much time as possible when emergency cases arrive.

Offices

There will generally be an administrative area within the department that includes offices for the ED medical director, nurse manager, and assistant nurse managers.

Functional Program

<i>Number</i>	<i>Department Area</i>	<i>Square Feet</i>
Movable Modular Casework		
_____	Patient Registration Area	_____
_____	Triage	_____
_____	Fast Track Clinic	_____
_____	Nurses Station	_____
_____	Charting/Dictation Area	_____
_____	Monitor Area	_____
_____	Radio Control Area	_____
_____	Medication Preparation Area	_____
_____	Nourishment Area	_____
_____	Exam Rooms @ _____ sq. ft.	_____
_____	Major Treatment/Trauma/Cardiac Rooms @ _____ sq. ft.	_____
_____	Cast Room	_____
_____	Observation/Holding Areas @ _____ sq. ft.	_____
_____	Psychiatric Holding/Exam Rooms	_____
_____	Equipment Storage Room	_____
_____	Clean Utility Room	_____
_____	Soiled Utility Room	_____
_____	Decontamination Area	_____
_____	Satellite Lab	_____
_____	Staff Toilets @ _____ sq. ft.	_____
_____	Janitor's Closet	_____
	Subtotal	_____
Modular Furniture Systems		
_____	Ambulance Personnel/Police Area	_____
_____	Family Counseling Room	_____
_____	Waiting Room or Lounge	_____
_____	Nurse Manager's Office	_____
_____	ED Physician Offices @ _____ sq. ft.	_____
_____	Staff Offices @ _____ sq. ft.	_____
	Subtotal	_____
	TOTAL NET SQUARE FEET	_____
	Net-to-Gross Conversion Factor	X _____
	TOTAL GROSS SQUARE FEET	_____

Bubble Diagram

The bubble diagram of the emergency department demonstrates typical departmental relationships and interaction between areas. Necessary adjacencies within the department become clear.

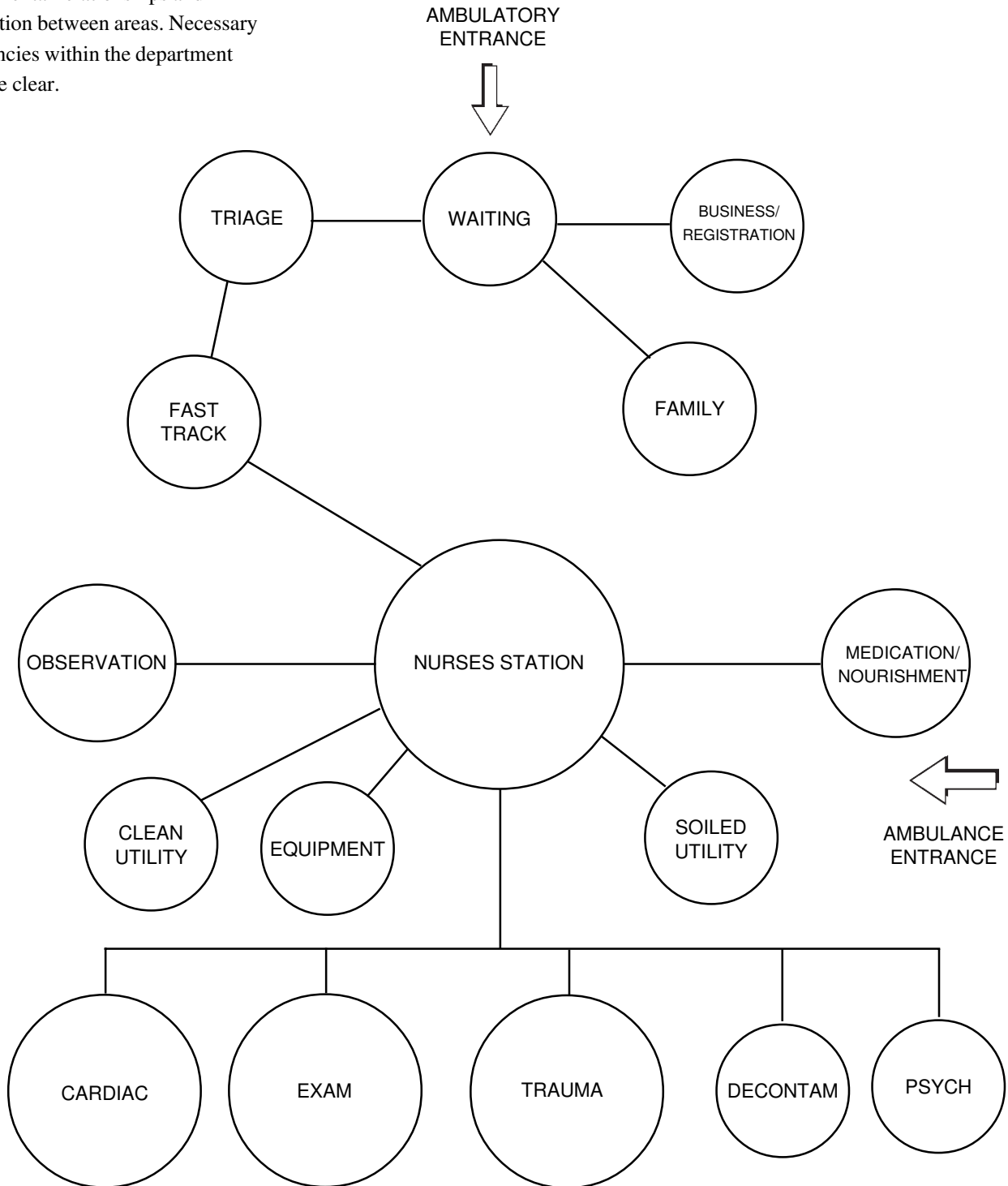

Block Diagram

The block diagram demonstrates the adjacencies and relative sizes for the areas within a typical emergency department. Evaluation of the work flow and materials flow from the bubble diagram has determined this initial general layout.

The size of each area is determined by combining the typical movable modular casework plans for each identified function. Traffic patterns are developed, and an overview of the general work process can be evaluated.

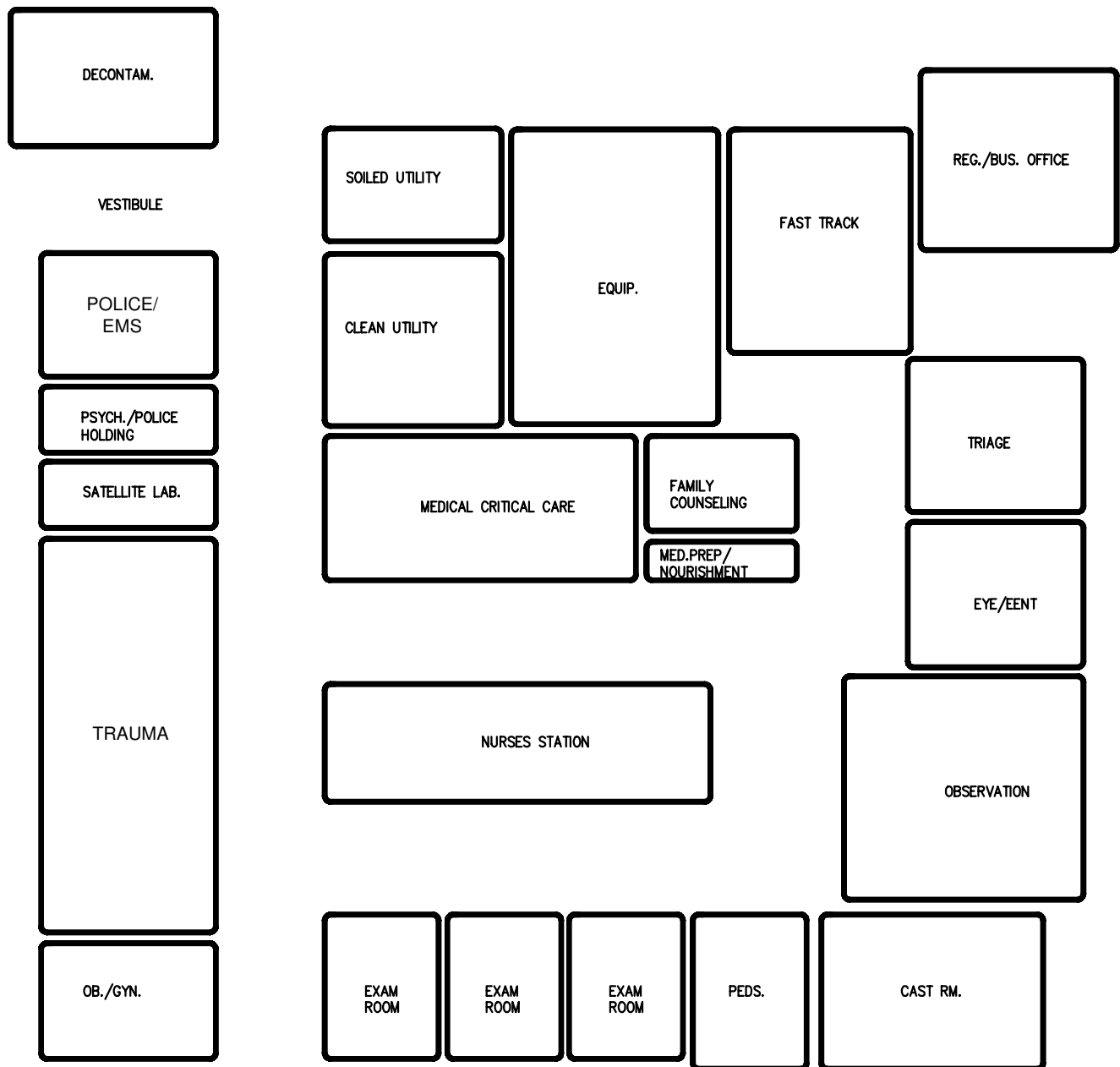

Preliminary Plan

The preliminary plan clarifies the emergency department space requirements by showing the location of all the fixed walls and open areas and identifies entrances, exits, and exact traffic patterns.

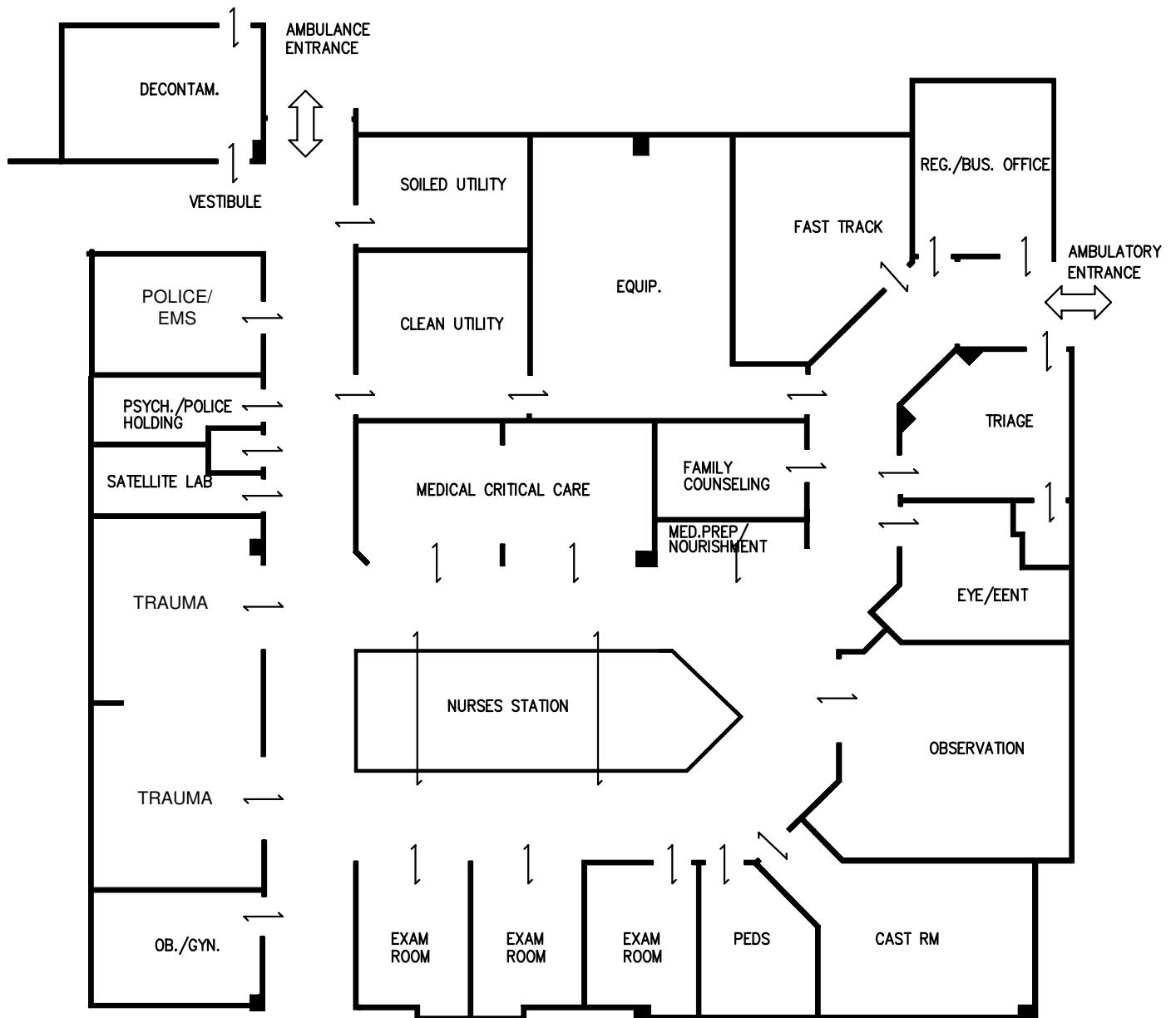

Schematic Plan

The schematic plan shows all of the specific movable modular casework, modular furniture systems, and materials handling components appropriate for a typical emergency department.

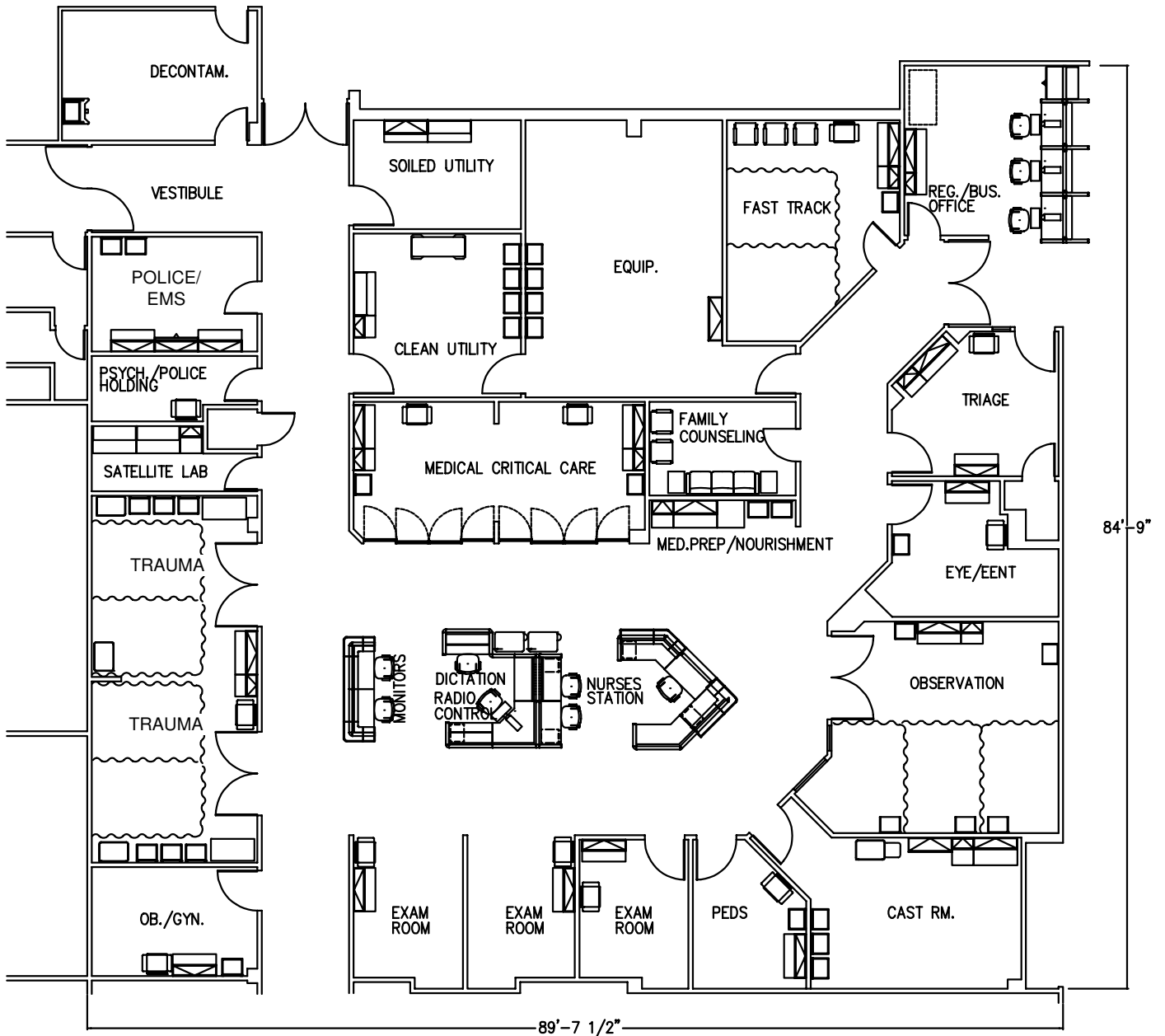

Future Trends

Marketing Strategies

Freestanding, privately owned clinics will continue to be competitive with hospital emergency departments. Hospitals are now attempting to provide all of the same services offered by private clinics and to market these services by advertising to the general public.

Patient Census

The overall average age of the population is continuing to increase resulting in many more acutely ill older people, many of whom will need emergency services.

Many people without health insurance seek emergency department care as a replacement for the family physician or clinic fee-for-service healthcare. Hospitals may provide these medical services in the emergency department regardless of the ability of the patient to pay for those services.

The continual increase in crime rates produces a comparable increase in traumatic injuries and drug-related emergencies.

All of the above factors will impact and continue to increase the number of patients seeking care in emergency departments.

Layout

With an increase in criminals as patients, patients with AIDS, and patients under the influence of illegal drugs, emergency room personnel must work in a stressful and sometimes dangerous environment. As a result, a high turnover in staffing will continue.

Planning for emergency departments must emphasize the comfort and safety of the staff. Layouts should provide traffic controls and security measures, including spaces for police, criminal lock-up rooms, and metal detectors where appropriate.

With new and constantly changing technology and equipment, there will be a need for not only larger spaces, but the ability to change the function of spaces. There will be fewer treatment rooms dedicated to a particular procedure or type of illness and more generic rooms that can be changed to accommodate whatever treatment is needed.

For the location of the sales facility or dealer near you, visit www.hermanmiller.com/healthcare or call (800) 628 0058.

© 1999 Herman Miller, Inc., Zeeland, Michigan

® HermanMiller, , Action Office, Aeron, Ambi, Arrio, Beirise Collection, Co/Struc, Custom Choices, Eames, Equa 2, Ergon 3, Ethospace, E-Wall, Frottage, Ground Cloth, Harmonics, Hollington, Intersite, Kinemat, Liaison, Meridian, Milcare, Mosaic, Newhouse Group, Pellicle, Perspectives, Proper, Pulsar, Rapid Response, Relay, Response Plus, Scooter, Super Room, Systems Bridge, Timepiece, V-Wall, and Wild Card are among the registered trademarks of Herman Miller, Inc.

™ , Aeron Chair Configuration, Ambassador, Burdick Group, Chadwick, CLT, CoActive, DIAMOND, Flex-Edge, Florence, ID, Iota, Milafin, Myriad, Passage, Potomac, Puzzle, Q, Raleigh, Rapunzel, and Traverse are among the trademarks of Herman Miller, Inc.

SM OASIS is a service mark of Herman Miller, Inc.

 **HermanMiller** for Healthcare