

# Automotive Foams

## Module 1



## ***IMPORTANT NOTICE***

---

This material provides general directions for collision damage repair using tested, effective procedures. Following them will help assure the reliability of the repair.

I-CAR cannot accept responsibility for any individual repair, nor can it warrant to the quality of such repair. Anyone who departs from the instructions in this program must first establish that neither personal safety nor the integrity of the repair of the vehicle is compromised by the choice of methods, tools, or supplies.

I-CAR does not endorse or recommend any brands or makes of vehicles, repair equipment and supplies or other products. The appearance of various makes and brand names in any I-CAR material is purely coincidental and is based on the availability of those products at the time of production.

All recommendations presented in this program are based upon research programs or upon tests conducted by laboratories, manufacturers, or selected collision repair facilities. If performed as outlined, these recommendations will provide the basis for a thorough, professional repair.

**© 2005–2012 by the Inter-Industry Conference On Auto Collision Repair (I-CAR) All Rights Reserved**



**Class  
1:04**



**A-1**

## MODULE 1—OVERVIEW OF AUTOMOTIVE FOAMS

### Topic A. Foam Uses

#### *Learning Objectives*

**Learning objectives for this module include:**

- explaining why foam is used in vehicles.
- identifying where foam may be located.
- identifying the different types of foam used in vehicles.
- explaining the uses of each type of foam.



Learning objectives for this module include:

- explaining why foam is used in vehicles.
- identifying where foam may be located.
- identifying the different types of foam used in vehicles.
- explaining the uses of each type of foam.

#### *Instructor Information*

Before beginning the class, take a moment to explain to the students the recommended prior programs.

Other programs required for a Certificate Of Professional Development Through Training in Non-Structural I include:

- Oxyacetylene/Plasma Arc Cutting (WCS05).
- Trim And Hardware (TRM01).
- Cosmetic Straightening Steel (STS01).
- Bolted-On Replacement Parts (EXT01).
- Movable Glass (GLA01).



A-2

## Topic A. Foam Uses (cont'd)

### *Reasons For Foam In Vehicles*



Foam is used in vehicles to:

- reduce noise, vibration and harshness (NVH). NVH may be caused by vehicle design, texture of the driving surface, or air passing along the vehicle.
- repair water leaks.
- stiffen the body structure and help control twisting and flexing of the vehicle.
- provide collision energy management.
- provide additional crash protection for occupant safety.

## *Instructor Information*

### *Objectives Worksheet*

Foam is used in vehicles to:

- reduce noise vibration and harshness (NVH). NVH may be caused by vehicle design, texture of the driving surface, or air passing along the vehicle.
- repair water leaks.
- stiffen the body structure and help control twisting and flexing of the vehicle.
- provide collision energy management.
- provide additional crash protection for occupant safety.



A-3

### Topic A. Foam Uses (cont'd)

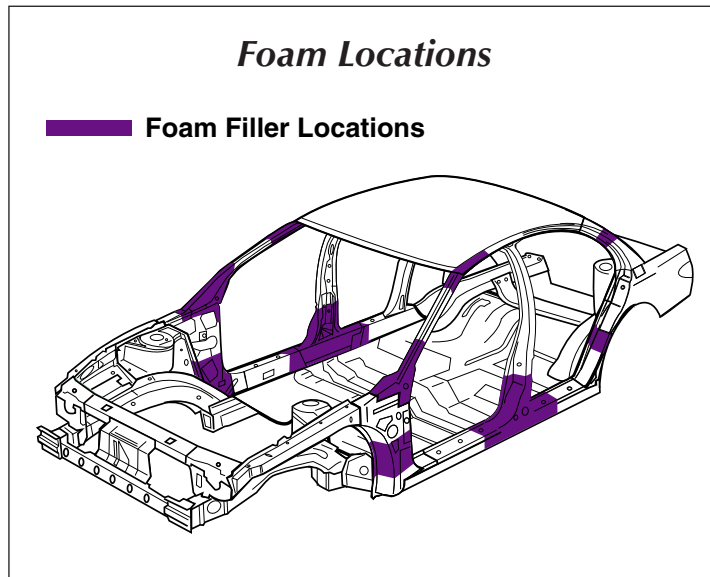

Foam may be located virtually anywhere on a vehicle. Some of the more common locations include:

- A-, B-, C-, and D-pillars.
- rocker panels and roof rails.
- frames and rails.
- crossmembers.
- between the roof skin and roof bows.
- between the door skin and intrusion beams.
- quarter panels.

### Instructor Information

#### Objectives Worksheet

Foam may be located virtually anywhere on a vehicle. Some of the more common locations include:

- A-, B-, C-, and D-pillars.
- rocker panels and roof rails.
- frames and rails.
- cross members.
- between the roof skin and roof bows.
- between the door skin and intrusion beams.
- quarter panels.

**Topic A. Foam Uses (cont'd)**

A-4

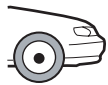
***NVH Control***

Expandable foam is used to block and absorb sound waves from entering the cabin of a vehicle. Typically, the softer the foam, the better it absorbs sound. Foam is also used to fill and seal cavities to reduce wind noise, and to hold panels in place to prevent flutter or vibration.

***Instructor Information***

**Topic A. Foam Uses (cont'd)****A-5*****NVH Control (cont'd)***

Expandable foam that is used for NVH control is commonly located at multiple areas within a vehicle chassis. Areas where the vehicle maker installed foam should be noted during repair so the correct locations receive the proper amount of replacement foam. These foam installation locations are critical for controlling noise. NVH foam is not designed to affect the structural integrity of a vehicle.

***Instructor Information***

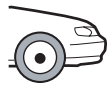
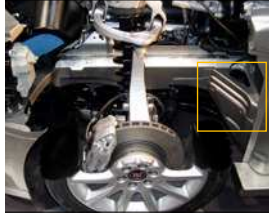

A-6

**Topic A. Foam Uses (cont'd)*****Common Structural Foam Locations***

Structural foam has limited applications. Structural foam is used for collision energy management and is very dense. Locations where structural foam is used include the:

- front lower rails. The 2004–2005 Cadillac CTS and STS use a structural foam block in the front lower rails.
- A-pillars. The 2003–2004 Ford Expedition, Navigator, and Chevrolet SSR use structural foam in the A-pillar area.
- D-pillars. The 2003–2004 Ford Expedition and Navigator use structural foam in the D-pillar area.
- full-frame torque box areas. The 2003 Ford Crown Victoria uses structural foam in the torque box areas of the frame.

***Instructor Information***





A-7

**Topic A. Foam Uses (cont'd)**

### ***Structural Enhancement***

**Structural Foam:**  
Structural Foam is a new technology material, which is being used in vehicles to reinforce joints, body panels, and cavities. This material is not the same as Acoustical Foams, Sound Deadeners, and Hem Adhesives. Structural Foam's are significantly different from any other foam product currently on the market. There are two types of structural foam applications that are being used in vehicles today.

► BODY BODY ZONE  
 2005-08 2009-11  
 2012-15  
 2016-18  
 2019-21  
 2022-24

**Acoustical Foam:**  
Acoustical foam is a new technology material, which is being used in vehicles to reduce noise, body panels, and cavities. This material is not the same as Structural Foam, Sound Deadeners, and Hem Adhesives. Acoustical foam's are significantly different from any other foam product currently on the market. There are two types of acoustical foam applications that are being used in vehicles today.

Structural foam is used to add rigidity and strength to the upper or lower areas of the vehicle. This limits the amount of twisting and flexing of an area, which helps control cracking and other damage from work hardening. This can also change the way a vehicle will perform in a collision.



**STRUCTURAL FOAM**

*Instructor Information*



A-8

## Topic A. Foam Uses (cont'd)

### *Structural Enhancement (cont'd)*



Structural foam can change the characteristics of a vehicle. Structural foam:

- increases strength and adds less weight than if additional steel were used.
- is typically used between engineering changes. With the use of structural foam, there is minimal disruption to the assembly process.
- is a highly dense material.
- has minimal expansion.

## *Instructor Information*

---

## *Objectives Worksheet*

---

Structural foam:

- increases strength of a part.
- is typically used between engi-  
neering changes.
- is highly dense material.
- has minimal expansion.

**Topic A. Foam Uses (cont'd)**

A-9

***NVH Foam Versus Structural Foam***

When comparing structural foam to NVH foam, NVH foam absorbs sound but it is not designed to provide crash protection. Structural foam is not designed for sound control, but provides crash protection.

**STRUCTURAL FOAM AND NVH FOAM*****Instructor Information***

**Topic A. Foam Uses (cont'd)**



A-10v

***Video: Structural Foam Strength***

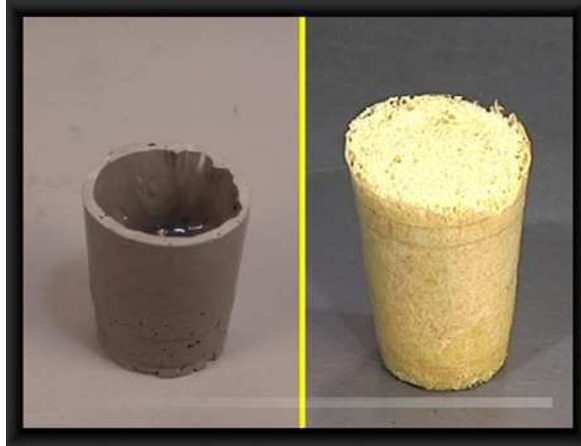

This video shows the differences between structural foam and rigid foam.

*Instructor Information*



A-11

**Topic A. Foam Uses (cont'd)*****Pre-Shaped Foam***

Some vehicle makers use pre-shaped foam blocks. These blocks may be:

- soft, compressible blocks that are stuffed into various locations for sound control. Typically, if a soft foam block is used, it is enclosed in a plastic bag to reduce the absorption of moisture.
- energy absorbing blocks that are used for crash protection.

**TYPES OF PRE-SHAPED FOAM*****Instructor Information***



A-12

## Topic A. Foam Uses (cont'd)

### *Impact Absorption*



Solid foam blocks are used to absorb collision energy. These blocks may be found in door shells or behind bumper covers. Depending on the vehicle maker, solid foam energy absorbers may be repairable if the damage is minimal and no pieces are missing.

Solid foam energy absorbing blocks are typically available as a service part. Saturn recommends that solid foam energy absorbing blocks used in the door assemblies must be reinstalled if they are removed, and replaced if damaged.

Chrysler allows their solid foam bumper energy absorbers to be repaired if no pieces are missing and the foam is not crushed.

General Motors requires replacement of damaged door-mounted energy absorbing foam blocks.

## *Instructor Information*

### *Objectives Worksheet*

Solid foam energy absorbing blocks are typically available as a service part. Solid foam energy absorbing blocks used in the door assemblies must be reinstalled if they are removed, and replaced if damaged.

Chrysler allows their solid foam bumper energy absorbers to be repaired if no pieces are missing and the foam is not crushed.



A-13

### Topic A. Foam Uses (cont'd)

#### *Energy Absorber Repair Considerations*



Solid foam bumper energy absorbers may be repairable if they are not crushed and if there are no missing pieces. To repair a solid foam energy absorber following the vehicle maker's procedure, clean the part with soap and water and use a urethane adhesive glue to attach the broken pieces.

#### *Instructor Information*

According to General Motors bulletin #07-08-63-001, because the energy absorbers are relatively low in cost to replace, it is now more cost efficient to replace the energy absorbers whenever they are damaged.

#### *Objectives Worksheet*

Solid foam bumper energy absorbers may be repairable if they are not crushed and if there are no missing pieces. To repair a solid foam energy absorber following the vehicle maker's procedure, clean the part with soap and water and use a urethane adhesive to attach the broken pieces.

## Topic B. Vehicle Maker Application And Curing Methods



B-1

### Vehicle Maker Application Methods



During vehicle assembly, foam may be installed in different ways. These include:

- drop-in, heat-activated material.
- two-part expandable foam that is pumped into locations and expands and cures by a chemical reaction. Two-part materials may be held in place by dams.



### FOAM CARRIERS

### Instructor Information

---

### Objectives Worksheet

---

During vehicle assembly, drop-in heat activated material, or two-part expandable foam that expands and cures by a chemical reaction may be used.



## Topic B. Vehicle Maker Application And Curing Methods (cont'd)



B-2

### *Vehicle Maker Application Methods (cont'd)*



Set-in position foam consists of two types. The first type is a solid material that is set into position and clipped or bolted to the door shell assembly. The other type of set-in position foam is flexible foam block. These blocks are typically encased in a plastic bag so they do not absorb water. Depending on the vehicle maker's design, these blocks may be located anywhere on the vehicle. Flexible foam parts may also be called stuffers.

### *Instructor Information*

---

### *Objectives Worksheet*

---

Set-in position foam consists of a:

- solid material that is set into position and clipped or bolted to the door shell assembly.
- flexible foam blocks which may be located anywhere on the vehicle.

**Topic B. Vehicle Maker Application And Curing Methods (cont'd)****B-3*****Heat-Activated Foam***

Heat-activated foams look like a putty-type material that expands during the E-coat baking cycle which is typically 218° C (425° F). Depending on the type of foam material used, this expansion may occur at temperatures between 37–148° C (100–300° F).

When installed, these materials may be placed between reinforcements and outer panels.

***Instructor Information***

**Topic B. Vehicle Maker Application And Curing Methods (cont'd)****B-4*****Heat-Activated Foam (cont'd)***

Heat-activated foam may be held in place by parts called carriers. These carriers may be snapped into adjacent panels where it would be difficult to access later in the vehicle assembly process. Depending on the vehicle maker, application, and material used, the expansion of heat-activated foam may be as much as 10 times its original size. Whenever possible, retain the carriers to reuse as dams when applying two-part expandable foam.

***Instructor Information***

## Topic B. Vehicle Maker Application And Curing Methods (cont'd)



B-5

### *Reasons For Use Of Heat-Activated Foam*

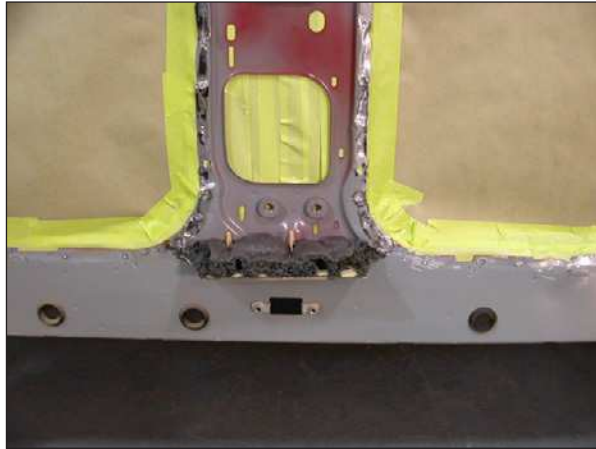

Heat-activated foam is used for a variety of reasons. Some of these reasons include:

- delayed activation. With heat-activated foam, there is no foam time to worry about because it will not expand until it is activated by heat. Foam time or work time is how long it takes for the foam to begin expanding and curing.
- precise placement. Without having to worry about foam time, these materials can be placed exactly where they are required.
- control over the amount of material being used.
- the ability to install the material at different points during the chassis assembly process.

### *Instructor Information*

---

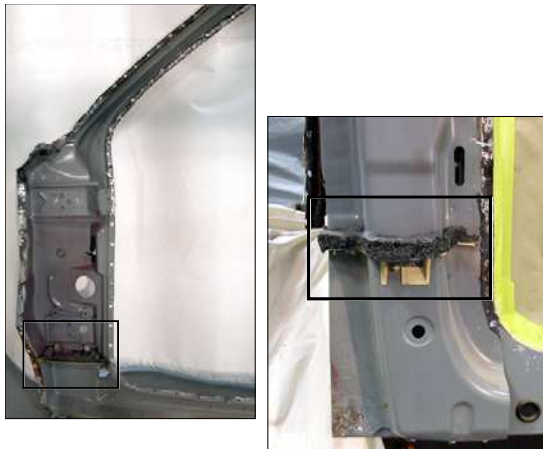
**Topic B. Vehicle Maker Application And Curing Methods (cont'd)****B-6*****Limitations Of Heat-Activated Foam***

Heat-activated foam is only used during new vehicle assembly because a repair facility is not able to safely reach foam activation temperatures in a paint booth. Trying to reach these temperatures may damage parts of the vehicle and jeopardize the safety of people in the surrounding area of the repair facility.

*Instructor Information*

**Topic B. Vehicle Maker Application And Curing Methods (cont'd)****B-7*****Chemical-Cure Foams***

Chemical-cure foams used during the vehicle assembly process:

- are two-part materials that mix together as they are dispensed.
- do not commonly require heat to cure.
- change state and expand while curing.
- fill voids for NVH control and structural enhancement.

***Instructor Information***

## Topic B. Vehicle Maker Application And Curing Methods (cont'd)



B-8

### Vehicle Maker Foam Chemistry



Foams used by vehicle makers during the assembly process:

- are epoxy-based if the foam is a structural material.
- are typically urethane if the foam is an NVH material.
- may not be identifiable as to whether the material is an epoxy or urethane.
- are closed cell. Closed cell materials are waterproof. Two-part expandable foam is closed cell until it is torn or cut.

### Instructor Information

---

## Topic B. Vehicle Maker Application And Curing Methods (cont'd)



B-9

### Vehicle Maker Replacement Materials

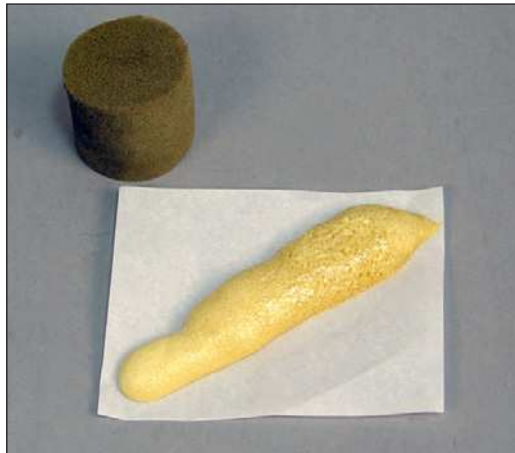

When using vehicle maker replacement materials, these materials may be:

- set-in position soft parts such as pre-cut foam.
- replaceable hard parts such as filler blocks where two-part foam is installed.
- a two-part material that cures by a chemical reaction and is retained in position by dams. Dams are used to contain foam in specific locations.

At least one vehicle maker uses a service part that reduces the amount of foam required to fill a location.

### Instructor Information

The 2003–2004 Ford Expedition or Mercury Mountaineer uses a service part to fill an area where replacement structural foam is installed. This service part reduces the amount of structural foam required. This information is listed in technical service bulletin (TSB) #04-8-2.

### Objectives Worksheet

Vehicle maker replacement materials may include:

- set-in position soft parts such as pre-cut foam.
- replaceable hard parts such as filler blocks where two-part foam is installed.
- a two-part material that cures by a chemical reaction and is retained in position by dams. Dams are used to contain foam in specific locations.
- a service part used that reduces how much structural foam is required in a specific location.





C-1

**Topic C. Review****Review#1**

Technician A says that during new vehicle assembly, foam may be installed in the A-pillar.

Technician B says that during new vehicle assembly heat activated foam may be used.

Who is right?

- A. A only
- B. B only
- C. Both A and B**
- D. Neither A nor B

Technician A says that during new vehicle assembly, foam may be installed in the A-pillar.

Technician B says that during new vehicle assembly, heat activated foam may be used.

Who is right?

- A. A only
- B. B only
- C. Both A and B**
- D. Neither A nor B

**Instructor Information**



C-2

**Topic C. Review (cont'd)****Review#2**

Technician A says that a heat-activated foam installed during new vehicle assembly may expand up to 10 times its liquid volume.

Technician B says that foams installed during new vehicle assembly process may require temperatures of 93° C (200° F) for activation.

Who is right?

- A. A only
- B. B only
- C. Both A and B
- D. Neither A nor B

Technician A says that a heat-activated foam installed during new vehicle assembly may expand up to 10 times its liquid volume.

Technician B says that foams installed during new vehicle assembly process may require temperatures of 93° C (200° F) for activation.

Who is right?

- A. A only
- B. B only
- C. Both A and B
- D. Neither A nor B

**Instructor Information**

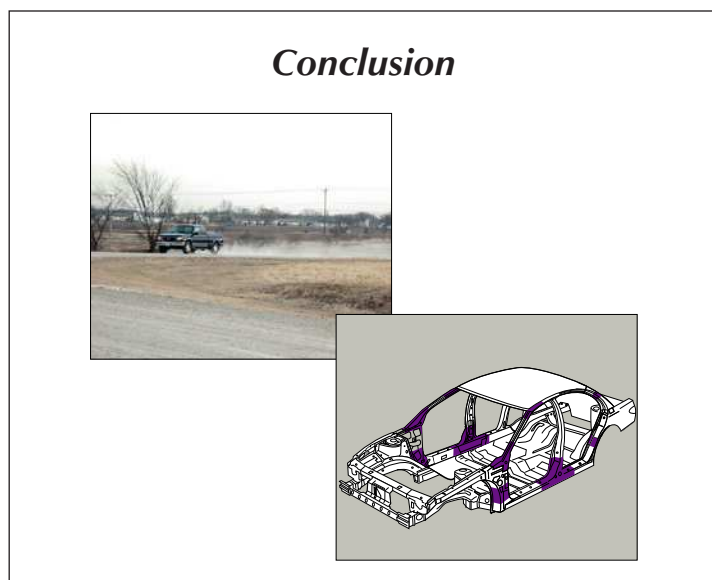

D-1

**Topic D. Conclusion**

Topics discussed in this module included:

- why foam is used in vehicles.
- where foam may be located.

---

*Instructor Information*

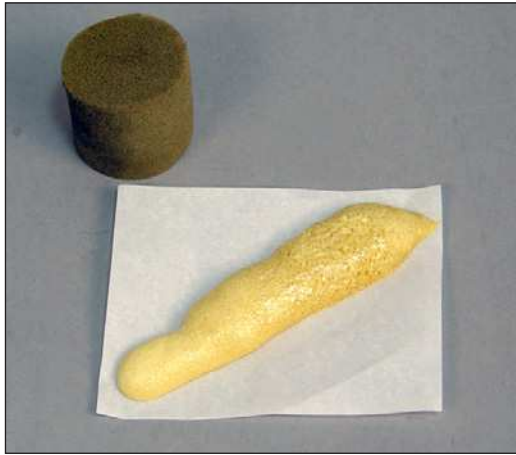
**Topic D. Conclusion (cont'd)****D-2****Conclusion (cont'd)**

Topics discussed in this module included the:

- different types of foam used in a vehicle.
- uses of each type of foam.

**Instructor Information****I-CAR Instructors**

You may choose to hand out Quiz #1 at this point for review. The quiz can be printed from the Instructor Preparation portion of this CD-ROM. The quizzes are an optional exercise.

**Career and Technical School and College Instructors**

Quiz #1 should be handed out at this point in the class. The quiz can be printed from the Instructor Preparation portion of this CD-ROM. Students can also print this quiz from their CD-ROM.

# Automotive Foams

Module 2





Class  
1:00



A-1

## MODULE 2—AUTOMOTIVE REPLACEMENT FOAM TYPES

### Topic A. Collision Repair Foam Materials

#### *Learning Objectives*

Learning objectives for this module include:

- identifying the differences between various foam types available for collision repairs.
- describing the uses for sound dampening material.
- explaining the difference between flexible and rigid foam.
- explaining where structural foam may be used.
- explaining the function of structural foam.

Learning objectives for this module include:

- identifying the differences between various foam types available for collision repairs.
- describing the uses for sound dampening material.
- explaining the difference between flexible and rigid foam.
- explaining where structural foam may be used.
- explaining the function of structural foam.

#### *Instructor Information*

---

## Topic A. Collision Repair Foam Materials (cont'd)



A-2

### Collision Repair Foam Chemistry



The chemistry of foam used for collision repair is similar to the material chemistry used by vehicle makers. These include:

- structural foam being epoxy based.
- NVH foam typically being urethane based. If a urethane-based material is opened and resealed, the shelf life of the material will be shorter than unopened material.
- materials being closed cell.

Some product makers list the product chemistry on the material label.

### Instructor Information

#### Objectives Worksheet

The chemistry of foam used for collision repair is similar to the material chemistry used by vehicle makers. These include:

- structural foam being epoxy based.
- NVH foam typically being urethane based. If a urethane-based material is opened and resealed, the shelf life of the material will be shorter than unopened material.
- materials being closed cell.

Some product makers listing the product chemistry on the material label.

**Topic A. Collision Repair Foam Materials (cont'd)**

A-3

***Foam Application Methods***

Collision repair foams are typically flow-grade, two-part materials that are dispensed and allowed to flow into a location where they expand and cure.

***Instructor Information***





B-1

## Topic B. Non-Expanding NVH Material

### Sound Dampening Material



Sound dampening material:

- does not expand like a two-part foam. Although commonly called foam, sound dampening material is more like a sealant and low-grade adhesive for use between parts.
- can be used as an adhesive to attach existing NVH foam to replacement panels.
- is designed to be applied to small gaps.
- has little or no expansion.
- has a longer work time than traditional two-part expanding foam.



### SOUND DAMPENING MATERIAL



### SOUND DAMPENING MATERIAL SAMPLE

## Instructor Information

### Objectives Worksheet

Sound dampening material:

- does not expand like a two-part foam. Although commonly called foam, sound dampening material is more like a sealant and low-grade adhesive for use between parts.
- can be used as an adhesive to attach existing NVH foam to replacement panels.
- is designed to be applied to small gaps.
- has little or no expansion and no visible cell structure.
- has a longer work time than traditional two-part expanding foam.



B-2

**Topic B. Non-Expanding NVH Material (cont'd)*****Sound Dampening Material  
Characteristics***

Sound dampening material:

- is usually black.
- looks like windshield urethane because it is usually the same color and has no visible cell structure.
- has a smooth surface texture when dispensed.
- has limited compression.
- is flexible.

---

*Instructor Information*

---



B-3

**Topic B. Non-Expanding NVH Material (cont'd)*****Sound Dampening Material  
Characteristics (cont'd)***

Sound dampening material:

- may require a special mixing tip.
- is not designed to be used in applications where cavities require filling.

*Instructor Information*



B-4

## Topic B. Non-Expanding NVH Material (cont'd)

### *Sound Dampening Material Uses*



Sound dampening material may be used:

- to reattach original foam that is being reinstalled. Some of these applications include reattaching the foam between a door skin and an intrusion beam, or roof skin and roof bows.
- between the quarter panel and the fuel-fill pocket.
- to fill small gaps, up to 13 mm (1/2").

### *Instructor Information*

#### *Objectives Worksheet*

Sound dampening material may be used:

- to reattach original foam that is being reinstalled. Some of these applications include reattaching the foam between a door skin and an intrusion beam, or roof skin and roof bows.
- between the quarter panel and the fuel pocket.
- to fill small gaps, up to 13 mm (1/2").



C-1

### Topic C. Flexible NVH Foam

#### *Flexible NVH Foam Characteristics*

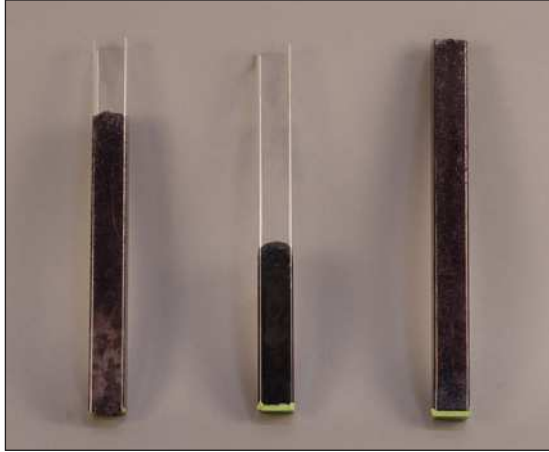

Flexible NVH foam is:

- low strength, with a high compression rate.
- extremely flexible, and does not permanently deform when compressed.
- typically black, but depending on the product maker, may be charcoal or white.
- able to expand up to 10 times its liquid volume.



#### **FLEXIBLE FOAM**

#### *Instructor Information*

#### *Objectives Worksheet*

Flexible NVH foam is:

- low strength, with a high compression rate.
- extremely flexible, and does not permanently deform when compressed.
- typically black, but depending on the product maker, may be charcoal or white.
- able to expand up to 10 times its liquid volume.



C-2

## Topic C. Flexible NVH Foam (cont'd)

### Flexible NVH Foam Characteristics (cont'd)



Flexible NVH foam:

- is combustible when heated to a high temperature. When foam is heated to temperatures above 300° C (575° F), the material will melt.
- is typically urethane based.
- has a short foam time. This time may range from a few seconds up to about 20 seconds.
- has no structural enhancement capabilities.
- is commonly referred to as anti-flutter foam.
- has a visible cell structure.

## Instructor Information

### Objectives Worksheet

Flexible NVH foam:

- is combustible when heated to temperatures above 300° C (575° F).
- is typically urethane based.
- has a short foam time.
- has no structural enhancement capabilities.
- is commonly referred to as anti-flutter foam.
- has a visible cell structure.



C-3

**Topic C. Flexible NVH Foam (cont'd)*****Flexible NVH Foam Uses***

Some uses for flexible foam include controlling panel flutter, absorbing and controlling sound, and blocking air movement. Another use for flexible foam includes filling large voids.

***Instructor Information***



C-4

**Topic C. Flexible NVH Foam (cont'd)*****Flexible NVH Foam Uses (cont'd)***

Some uses for flexible foam include sealing out dust and repairing water leaks. Flexible foam can be used for repairing water leaks because the material does not absorb water and seals tight to the surrounding area.

***Instructor Information***





C-5

**Topic C. Flexible NVH Foam (cont'd)*****Flexible NVH Foam Locations***

Some locations where flexible foam may be found include:

- where the roof skin attaches to the crossbeams and where it attaches to the roof side rails.
- between the door skin and the intrusion beam.
- inside any of the pillars.

***Instructor Information***



C-6

### Topic C. Flexible NVH Foam (cont'd)

#### *Flexible NVH Foam Locations (cont'd)*



Locations where flexible foam may be found include:

- behind the quarter panels at the:
  - fuel fill pockets.
  - wheelhouse and quarter panel.
  - dog legs of the C- or D-pillar.
  - rear body panel-to-quarter panel joint.
  - door striker inner plate area.
- inside rocker panels.
- inside upper rails.

#### *Instructor Information*

---



D-1

## Topic D. Rigid NVH Foam

### *Rigid NVH Foam Characteristics*



Rigid NVH foam:

- is packaged under many different names. These names include semi-rigid, pillar, and rigid foam. Rigid foams are urethane based.
- is more rigid than flexible foam.
- will permanently deform when compressed.
- has a limited compression rate before it permanently deforms.



## RIGID FOAM

### *Instructor Information*

### *Objectives Worksheet*

Rigid NVH foam:

- is packaged under many different names. These names include semi-rigid, pillar, and rigid foam.
- is urethane based.
- has a limited compression rate before it permanently deforms.



D-2

## Topic D. Rigid NVH Foam (cont'd)

### *Rigid NVH Foam Characteristics (cont'd)*



Rigid NVH foam:

- such as pillar foam, has an extended foam time. This allows pillar foam to flow down into the parts before expanding.
- may expand up to 10 times its non-expanded volume.
- provides limited chassis reinforcement.
- is not a replacement material for structural foam.
- typically has a visible cell structure.

## *Instructor Information*

### *Objectives Worksheet*

Rigid NVH foam:

- such as pillar foam, has an extended foam time.
- may expand up to 10 times its non-expanded volume.
- provides limited chassis reinforcement.
- is not a replacement material for structural foam.
- typically has a visible cell structure.



D-3

### Topic D. Rigid NVH Foam (cont'd)

#### *Rigid NVH Foam Uses*



Rigid NVH foam is commonly used for:

- NVH control, such as absorbing sound, blocking air, and helping control movement of body parts and panels.
- cushioning adjacent parts. An example of this type of application is using this product between the inner and outer B-pillar of the 2005 Volvo S-40. This material limits sound and, because of their close proximity, eliminates the two parts from rattling against each other.

Rigid foam must NEVER be considered a replacement material for structural foam.

#### *Instructor Information*

#### *Objectives Worksheet*

Rigid NVH foam is commonly used for:

- NVH control, such as absorbing sound, blocking air, and helping control movement of body parts and panels.
- cushioning adjacent parts.

Rigid foam must NEVER be considered a replacement material for structural foam.



D-4

**Topic D. Rigid NVH Foam (cont'd)*****Rigid NVH Foam Uses (cont'd)***

Though not used for structural enhancement or to change crash characteristics, rigid foam may be used to stiffen the vehicle structure to minimize twisting and flexing.

---

*Instructor Information*

---



D-5

### Topic D. Rigid NVH Foam (cont'd)

#### *Rigid Foam Locations*



Common locations where rigid foam may be found includes:

- pillars.
- rocker panel.
- dog legs.
- quarter panels.
- rails.
- front or rear roof bows.

Rigid foam is used in the lower dog leg area and lower B-pillar of the 2004 Chrysler Pacifica.

#### *Instructor Information*

#### *Objectives Worksheet*

Common locations where rigid foam may be found includes:

- pillars.
- rocker panel.
- dog legs.
- quarter panels.
- rails.
- front or rear roof bows.



E-1

## Topic E. Structural Foam

### *Structural Foam Characteristics*



Structural foam:

- is stronger than rigid foam.
- is not flexible. Structural foam is a hard material that is prone to cracking rather than deforming.
- is a hard plastic-like material.
- has the appearance of an adhesive when dispensed due to its cell structure and surface appearance.



## STRUCTURAL FOAM

### *Instructor Information*

---

### *Objectives Worksheet*

---

Structural foam:

- is stronger than rigid foam.
- is not flexible. Structural foam is a hard material that is prone to cracking rather than deforming.
- is a hard plastic-like material.
- has the appearance of an adhesive when dispensed due to its cell structure and surface appearance.





E-2

## Topic E. Structural Foam (cont'd)

### *Structural Foam Characteristics (cont'd)*



Structural foam:

- is a heavy-bodied, two-part flow-grade material.
- has a minimal expansion rate. The expansion rate of structural foam can be between 25% and 40%, depending on how thoroughly and how long the material was heated before being dispensed.
- is offered by only a limited number of suppliers.
- is used to structurally enhance a vehicle. These changes will affect the crash characteristics.

### *Instructor Information*

---



E-3

### Topic E. Structural Foam (cont'd)

#### *Structural Foam Uses*



Structural foam is used:

- where stiffening of the vehicle structure is required.
- for managing collision energy.

Structural foam is not a material that should be used for noise control. Using structural foam for NVH control may actually create problems rather than fix them. This is because structural foam has the ability to transfer or amplify sound.

#### *Instructor Information*



E-4

## Topic E. Structural Foam (cont'd)

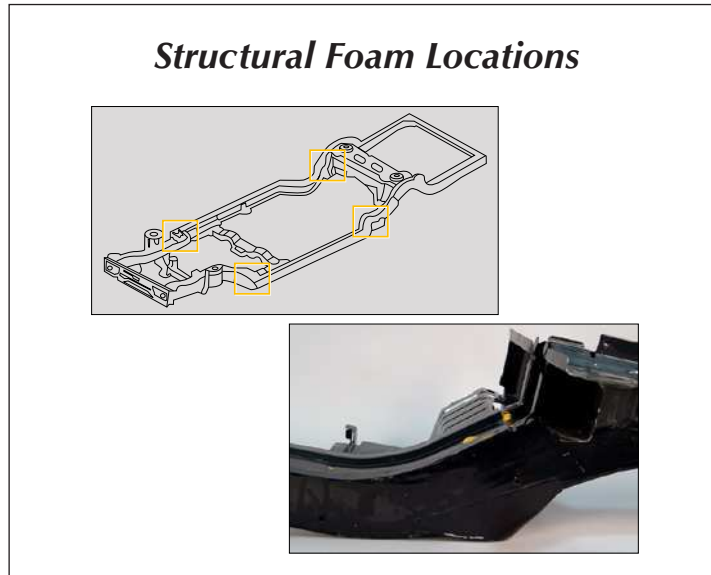

When replacing structural foam, it is critical that it is replaced in the original location and only where the vehicle maker identified. If the material is over-used or under used, the integrity of the vehicle could be drastically affected. Some locations where structural foam may be found include:

- pillars.
- torque box areas of full frame vehicles.
- front lower rails.

According to Ford TSB #04-8-2, replacement structural foam should be heated to 46–74° C (115–165° F). Doing this helps the material dispense easier than if it was at room temperature. Heating also allows the material to expand.

## Instructor Information

### Objectives Worksheet

According to Ford TSB # 04-8-2, replacement structural foam should be heated to 46–74° C (115–165° F) before it is dispensed.



F-1

**Topic F. One-Part Foam**

***Consumer Foam***



Consumer foam should not be used for any automotive applications. Consumer foams are a one-part material and require moisture to cure. The aerosol, one-part urethane cures by absorbing moisture from the air and can continue to absorb water. In an enclosed area, such as inside a body panel, it may never cure completely. This may cause corrosion problems, inadequate filling on an area and inadequate NVH control. This means that if a one-part material is injected into a part and there is no moisture to help it cure, the material will dissolve and create hollow spots. Another negative characteristic of consumer foams is its open cell structure, meaning it will absorb water.

*Instructor Information*



**CONSUMER FOAM**



**CONSUMER FOAM SAMPLE**



G-1

**Topic G. Review*****Review #1***

**Technician A says that some rigid type foams have a delayed foam time.**

**Technician B says that pillar foam is a replacement material for structural foam.**

**Who is right?**

- A. A only**
- B. B only**
- C. Both A and B**
- D. Neither A nor B**

Technician A says that some rigid type foams have a delayed foam time.

Technician B says that pillar foam is a replacement material for structural foam.

Who is right?

- A. A only**
- B. B only**
- C. Both A and B**
- D. Neither A nor B**

***Instructor Information***



G-2

**Topic G. Review (cont'd)****Review #2**

All of these are true about consumer foams EXCEPT they:

- A. are closed cell.
- B. absorb water.
- C. look like a rigid-type foam.
- D. require moisture to cure.

All of these are true about consumer foams EXCEPT they:

- A. are closed cell.**
- B. absorb water.
- C. look like a rigid-type foam.
- D. require moisture to cure.

---

*Instructor Information*

---



H-1

## Topic H. Conclusion

### Conclusion



Topics discussed in this module included:

- differences between various foam types supplied by the aftermarket industry.
- uses for sound dampening material.

### Instructor Information



H-2

## Topic H. Conclusion (cont'd)

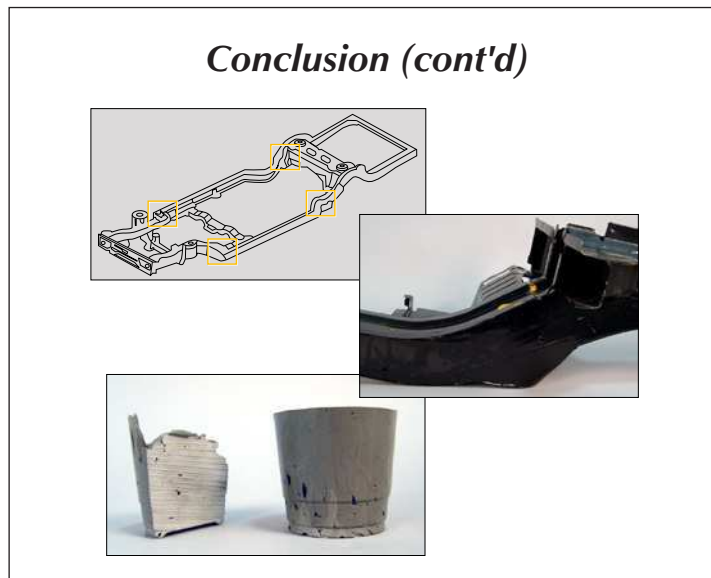

Topics discussed in this module included:

- the difference between flexible and rigid foam.
- where structural foam may be used.
- functions of structural foam.

### *Instructor Information*

#### **I-CAR Instructors**

You may choose to hand out Quiz #2 at this point for review. The quiz can be printed from the Instructor Preparation portion of this CD-ROM. The quizzes are an optional exercise.

#### **Career and Technical School and College Instructors**

Quiz #2 should be handed out at this point in the class. The quiz can be printed from the Instructor Preparation portion of this CD-ROM. Students can also print this quiz from their CD-ROM.



# Automotive Foams

Module 3





**Class**  
**0:45**



**A-1**

## **MODULE 1–FOAM SAFETY AND REPAIR**

### **Topic A. Safety When Working With Foam**

#### ***Learning Objectives***

**Learning objectives for this module include:**

- **identifying the proper safety equipment that should be worn when working with foam.**
- **explaining safety considerations when working around foam with heat.**
- **identifying foam that is installed by the vehicle maker.**
- **making foam samples for comparison.**
- **comparing vehicle maker foam to replacement foam samples.**

Learning objectives for this module include:

- identifying the proper safety equipment that should be worn when working with foam.
- explaining safety considerations when working around foam with heat.
- identifying foam that is installed by the vehicle maker.
- making foam samples for comparison.
- comparing vehicle maker foam to replacement foam samples.

#### *Instructor Information*



A-2

## Topic A. Safety When Working With Foam (cont'd)



When working with expandable foam, specific safety equipment that should be used includes:

- a respirator. From the time foam is dispensed until it expands and is cured, there are chemicals released which are harmful. Choose a respirator that is designed to filter out fumes from uncured foam. When working with two-part expandable foams, an organic vapor respirator should be worn. This respirator is color-coded with a black filter cartridge.
- light-duty vinyl gloves. Vinyl gloves protect bare skin from contacting the foam. Unprotected skin contact with foam can cause irritation or burns.
- a fire extinguisher. When doing repairs that require heating near foam, keep a fire extinguisher nearby. Because foam is a chemical based product, a class B fire extinguisher should be used.
- safety goggles or glasses, or a face shield.

## Instructor Information

### Objectives Worksheet

When working with expandable foam, specific safety equipment that should be used includes:

- a respirator. From the time foam is dispensed until it expands and is cured, there are chemicals released which are harmful. Choose a respirator that is designed to filter out fumes from uncured foam. When working with two-part expandable foams, an organic vapor respirator should be worn. This respirator is color-coded with a black filter cartridge.
- light-duty vinyl gloves. Vinyl gloves protect bare skin from contacting the foam. Unprotected skin contact with foam can cause irritation or burns.
- a fire extinguisher. When doing repairs that require heating near foam, keep a class B fire extinguisher nearby.
- safety goggles or glasses, or a face shield.
- the material safety data sheet (MSDS) for the product being used. This document offers information on special handling, safety equipment, clean-up procedures, and emergency medical information.
- the technical data sheet, which may provide tips regarding safe ways to handle the product or tips about how the product will react when dispensed.

**Topic A. Safety When Working With Foam (cont'd)**

- the material safety data sheet (MSDS) for the product being used. Having the MSDS available will offer information regarding special handling information, suggested safety equipment, clean-up procedures, and emergency medical information.
- the technical data sheet, which may provide tips regarding safe ways to handle the product or tips about how the product will react when dispensed.

**FOAM MSDS****PERSONAL PROTECTION EQUIPMENT***Instructor Information*



A-3

**Topic A. Safety When Working With Foam (cont'd)*****Safety When Working Near Foam***

When working near areas on a vehicle that may have foam:

- know where the foam is located. This information may be identified in a body repair manual or other repair information provided by the vehicle maker.
- do not heat with an open flame. Foam is combustible and will burn. If the foam begins to smolder or burn, the fumes are toxic, and smoke or fire damage may occur to the vehicle or part being worked on.

***Instructor Information***

## Topic A. Safety When Working With Foam (cont'd)



A-4

### Safety When Working Near Foam (cont'd)



Do not weld near foam filler. Foam should be removed from areas near the weld zone. Typically, cured foam will melt if exposed to heat higher than 300° C (575° F). When cured foam begins to melt, it generates toxic chemicals, including carbon monoxide and cyanide gas. Foam inside a part will not melt when cut with a saw. A heat gun should be used for releasing foam from a part.

## Instructor Information

### Objectives Worksheet

Do not weld near foam filler. Foam should be removed from areas where welding will be done. Typically, cured foam will melt if exposed to heat higher than 300° C (575° F). When cured foam begins to melt, it generates toxic chemicals, including carbon monoxide and cyanide gas. Foam inside a part will not melt when cut with a saw.



B-1

## Topic B. Identifying Vehicle Maker Foam

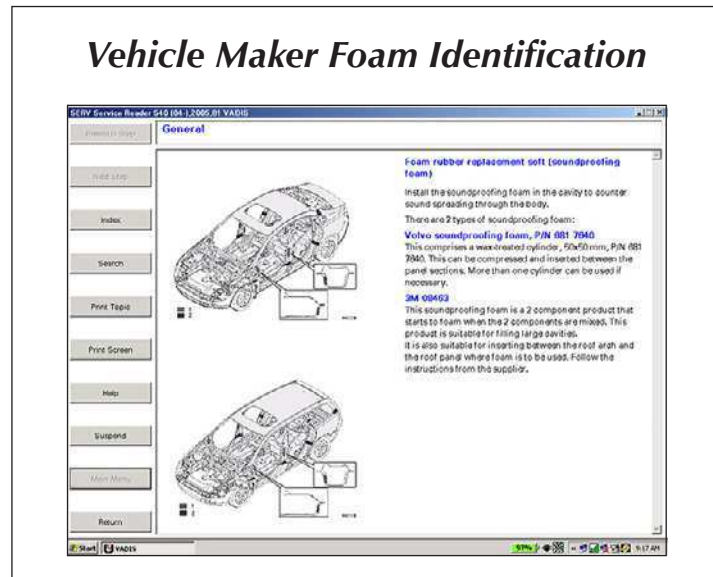

Vehicle makers may identify the location and type of foam used in a vehicle. This information may be located:

- in specific vehicle repair information, such as body repair manuals or service manuals.
- in a TSB.
- online within vehicle maker service information.
- by calling the vehicle maker's technical information hotline.

Determining foam type from vehicle maker information may not be possible. There may be situations where the type of foam and its use is not identified.

## Instructor Information



B-2

## Topic B. Identifying Vehicle Maker Foam (cont'd)

### Vehicle Maker Foam Identification (cont'd)

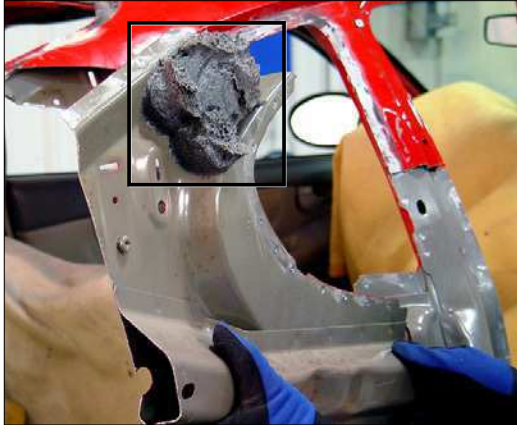

Some ways of identifying foam that has been installed by the vehicle maker include:

- visually inspecting the materials cell structure and color.
- identifying the material. This includes identifying the texture, brittleness, and compression resistance of the foam.

## Instructor Information

### Objectives Worksheet

Some ways of identifying foam that has been installed by the vehicle maker include:

- visually inspecting the materials cell structure and color.
- identifying the material. This includes identifying the texture, brittleness, and compression resistance of the foam.





B-3

**Topic B. Identifying Vehicle Maker Foam (cont'd)*****Vehicle Maker Flexible Foam***

When identifying a vehicle maker's flexible foam, it will:

- typically be black, but may be gray or white.
- be soft, easily torn, and easy to compress without permanent deformation.
- have a visible cell structure when torn. Flexible foams typically have a visible cell structure.

***Instructor Information***

**Topic B. Identifying Vehicle Maker Foam (cont'd)****B-4*****Vehicle Maker Rigid Foam***

When identifying a vehicle maker's rigid foam, it will:

- typically be white or yellow.
- be hard and brittle, and will break or crack when flexed.
- not re-close where it was pierced. When pierced, it will permanently deform.
- have a visible cell structure when cut or broken.
- permit a limited amount of compression. Compared to flexible foam, rigid foam has an increased compression resistance.

***Instructor Information***



B-5

**Topic B. Identifying Vehicle Maker Foam (cont'd)*****Vehicle Maker Structural Foam***

When identifying a vehicle maker's structural foam, it may:

- be gray or orange.
- be a high-density material. Depending on the vehicle maker and the type of material used, there may be no visible cell structure. Gray structural foam is a solid and hard plastic-like material, the orange structural foam has small cell structure, and is not quite as solid as the gray material.
- be hard and brittle. Structural foam is a material that is brittle. It will break, but depending on the material, can not be pierced.
- have no compression without breaking. Structural foam has the greatest compression resistance when compared to flexible or rigid foam.

**SERVICE PART WITH STRUCTURAL FOAM*****Instructor Information***



C-1

## Topic C. Determining Replacement Materials

### *Vehicle Maker Recommendations*



When determining which replacement material to use, the vehicle maker may have recommendations. If these recommendations exist, they may be:

- listed in the vehicle maker service manual. Service procedures or parts may call for a specific foam to be used.
- listed in a TSB.
- available from information listed in the parts ordering system.

### *Instructor Information*

**Topic C. Determining Replacement Materials (cont'd)**

*Instructor Information*



C-2

**Product Maker Recommendations**

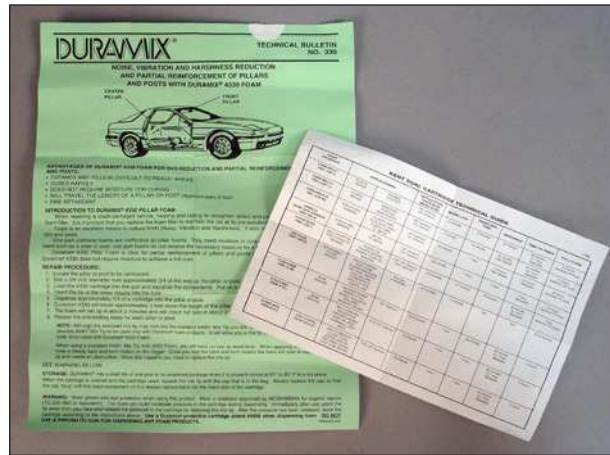

When deciding which replacement material to use, the foam maker may have specific recommendations. If these recommendations exist, they may be:

- listed on the tech sheet.
- acquired by calling the product maker’s hot-line.
- identified by inquiring from a product maker’s distributor or representative.



C-3

**Topic C. Determining Replacement Materials (cont'd)***Instructor Information****Comparing Foam Samples***

If not identified by the vehicle maker, compare replacement samples to the material installed by the vehicle maker. When doing this, duplicate what the vehicle maker installed as best as possible. Though the type of foam is important, the color is not.



C-4

**Topic C. Determining Replacement Materials (cont'd)***Instructor Information****Comparing Foam Samples (cont'd)***

When comparing foam samples, consider:

- **compression.** When comparing the compression characteristics, determine if the foam will compress and how much force is required to do this. Also, determine if the foam remains permanently deformed after it has been compressed or if it springs back to its original shape after the force is removed.
- **density.** When determining the density of a material, evaluate the type of cell structure and weight of the material. A material with a large cell structure will typically be less dense than a small cell structure material.
- **texture.**
- **cell structure.**

Try to find a replacement material that is a near exact match to the material used by the vehicle maker.



C-5

## Topic C. Determining Replacement Materials (cont'd)

### Making Foam Samples



When making foam samples:

- it may be necessary to create multiple foam samples from multiple foam makers.
- a sample of each type of replacement material may be necessary to ensure the closest match.
- disposable containers, such as plastic drinking cups or paper bowls, work well.
- cut the sample to create a viewable cross section.



### FOAM SAMPLES

## Instructor Information

### Objectives Worksheet

When making foam samples:

- it may be necessary to create multiple foam samples from multiple foam makers.
- a sample of each type of replacement material may be necessary to ensure the closest match.
- disposable containers, such as plastic drinking cups or paper bowls, work well.
- cut the sample to create a viewable cross section.





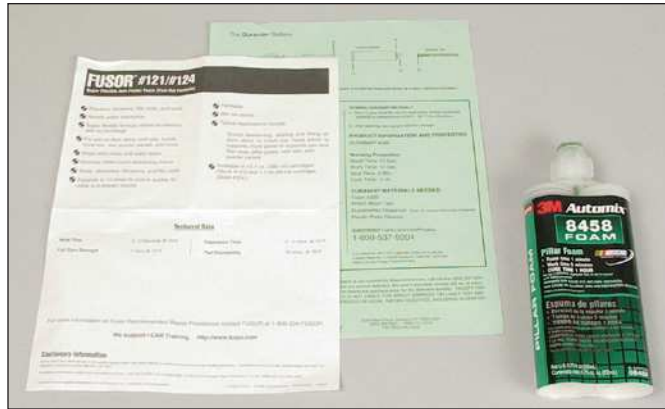

C-7

**Topic C. Determining Replacement Materials (cont'd)***Instructor Information****Choosing Replacement Material***

When choosing a replacement material, ensure it can be installed into locations where the vehicle maker installed the original material. Considerations for this include:

- flow rate. Flow rate refers to the viscosity of the material and how it will flow or move down an angled or vertical surface.
- foam time. Foam time or work time is how long it takes for the foam to begin expanding.



C-8

### Topic C. Determining Replacement Materials (cont'd)

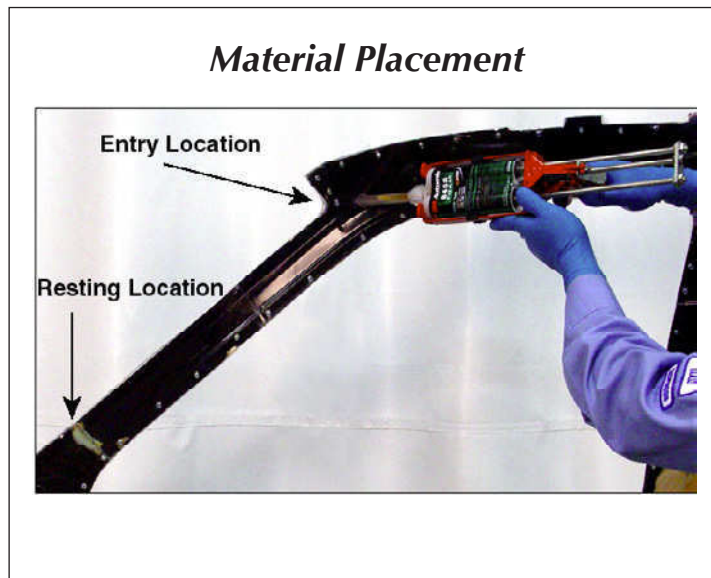

When choosing a replacement material, there is a relationship between the location the material is introduced into the part and the intended location. This relationship will have an influence regarding which material should be used and the procedure for installation. For example, if a material is required to be at the bottom of a part and the only access location is at the top of the part, a material with a fast flow rate and a long foam time will be the best choice. Suspending a foam midway in a part may be easier using a material with a slower flow rate and a faster foam time.

### Instructor Information

#### Objectives Worksheet

When choosing a replacement material, there is a relationship between the location the material is introduced into the part and the intended location. This relationship will have an influence regarding which material should be used and the procedure for installation.



C-9

## Topic C. Determining Replacement Materials (cont'd)

### *Determining How Much Material To Use*



When determining how much material to use in a part, some considerations for expandable foam include the:

- expansion rate of the material.
- volume of the part being filled. The volume can be calculated using the approximate length, width, and height of the part. Knowing the length, width, and height of a part can allow a technician to estimate how much foam is required to fill a part.

If the approximate volume of the area to be filled, and the expansion rate of the material used is known, an estimate can be made of how much unexpanded material is required. From this estimated amount, it can be determined how much of the tube, or how many tubes of material are required.



### SHAPES OF VOIDS

### *Instructor Information*

The Activity icon links to a screen showing three different shapes that a technician may encounter on a vehicle. The information on this screen will not be on the post-test.



D-1

**Topic D. Review*****Review #1***

**Technician A says that foam samples can be used to compare the density of replacement foam to the material used on a vehicle.**

**Technician B says that foam samples can be used to compare the texture of replacement foam to the material used on a vehicle.**

**Who is right?**

- A. A only**
- B. B only**
- C. Both A and B**
- D. Neither A nor B**

Technician A says that foam samples can be used to compare the density of replacement foam to the material used on a vehicle.

Technician B says that foam samples can be used to compare the texture of replacement foam to the material used on a vehicle.

Who is right?

- A. A only
- B. B only
- C. Both A and B**
- D. Neither A nor B

***Instructor Information***



D-2

**Topic D. Review (cont'd)****Review #2**

Technician A says that foam time is a consideration when determining which material should be used.

Technician B says that flow rate may determine where a material is positioned.

Who is right?

- A. A only
- B. B only
- C. Both A and B
- D. Neither A nor B

Technician A says that foam time is a consideration when determining which material should be used.

Technician B says that flow rate may determine where a material is positioned.

Who is right?

- A. A only
- B. B only
- C. **Both A and B**
- D. Neither A nor B

**Instructor Information**

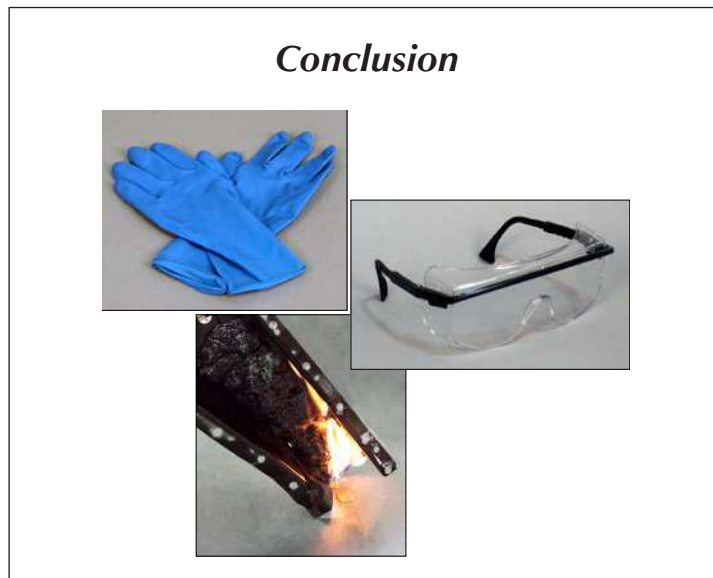

E-1

**Topic E. Conclusion**

Topics discussed in this module included:

- the proper safety equipment that should be worn when working with foam.
- considerations when working around foam with heat.

---

*Instructor Information*

---

**Topic E. Conclusion (cont'd)****E-2****Conclusion (cont'd)**

Topics discussed in this module included:

- foam installed by the vehicle maker.
- comparing foam samples.
- vehicle maker foam to replacement foam sample comparison.

**Instructor Information****I-CAR Instructors**

You may choose to hand out Quiz #3 at this point for review. The quiz can be printed from the Instructor Preparation portion of this CD-ROM. The quizzes are an optional exercise.

**Career and Technical School and College Instructors**

Quiz #3 should be handed out at this point in the class. The quiz can be printed from the Instructor Preparation portion of this CD-ROM. Students can also print this quiz from their CD-ROM.



# Automotive Foams

Module 4





Class  
1:11



A-1

## MODULE 1—PREPARING PARTS FOR FOAM

### Topic A. Part Preparation

#### *Learning Objectives*

Learning objectives for this module include:

- explaining tools and techniques used to remove foam.
- preparing a new part for foam installation.
- preparing parts with existing foam for new foam installation.
- reattaching foam that is being reused.
- explaining which materials can be used for making dams.
- explaining expansion rate variables for foam.

Learning objectives for this module include:

- explaining tools and techniques used to remove foam.
- preparing a new part for foam installation.
- preparing parts with existing foam for new foam installation.
- reattaching foam that is being reused.
- explaining which materials can be used for making dams.
- explaining expansion rate variables for foam.

#### *Instructor Information*



A-2

## Topic A. Part Preparation (cont'd)

### ***General Part Preparation Consideration***

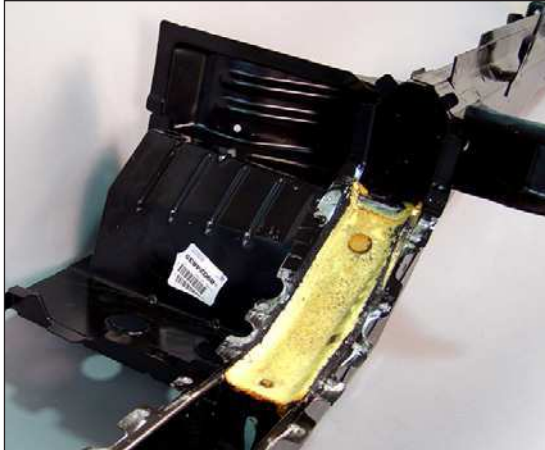

When preparing a part for installation:

- new or existing foam may require installation before attaching the part to the vehicle.
- partial or complete removal of the existing foam before new foam is installed may be required. This occurs when welding is required in an area where foam is located or in an area where foam is damaged. If foam is crushed and no longer adhered to the part, it should be removed.

### *Instructor Information*



A-3

## Topic A. Part Preparation (cont'd)

### *General Part Preparation Consideration (cont'd)*



When preparing a part for foam:

- ensure areas that will receive foam are clean and dry.
- prime all bare metal areas to reduce the chance of corrosion. When priming, apply an epoxy or urethane primer. If acid-etch primers are used, they must be fully cured before foam is applied. Because structural foam is epoxy based, the use of an epoxy primer is recommended under any structural foam.

## *Instructor Information*

### *Objectives Worksheet*

When preparing a part for foam:

- ensure areas that will receive foam are clean and dry.
- prime all bare metal areas to reduce the chance of corrosion. When priming, apply an epoxy or urethane primer. If acid-etch primers are used, they must be fully cured before foam is applied. Because structural foam is epoxy based, the use of an epoxy primer is recommended under any structural foam.



A-4

### Topic A. Part Preparation (cont'd)

#### Foam Removal



Some tools and techniques used for removing foam include:

- chisels. Using a dull chisel may help reduce the chance of damaging the part during foam removal.
- abrasives for rigid and structural foam.
- heat. Heat is useful when releasing undamaged foam for reuse. Even if the foam is not being reused, heat may help release foam from a part.
- scrapers.
- knives.
- rolling the foam off by hand. Flexible foam can be rolled off the surface of the part by wearing rubber gloves and rubbing.

#### Instructor Information

#### Objectives Worksheet

Some tools and techniques used for removing foam include:

- chisels.
- abrasives for rigid and structural foam.
- heat.
- scrapers.
- knives.
- rolling the foam off by hand.



A-5

**Topic A. Part Preparation (cont'd)**

Cleaning areas for foam installation is similar to cleaning a part for refinishing. The first step is to use a water-based cleaner. Water-based cleaners will not remove contaminants that are solvent-based.

The second cleaning step is to use a solvent-based cleaner. Solvent-based cleaners will not remove water-based contaminants.

After cleaning, prime bare metal areas.

**Instructor Information**



A-6

**Topic A. Part Preparation (cont'd)*****Preparing Recycled Parts For Foam***

When preparing recycled parts for foam:

- avoid applying cleaners to existing foam.
- ensure cleaners have dried or evaporated before installing the part or applying foam.
- remove existing rigid-type foam by grinding.

***Instructor Information***



A-7

## Topic A. Part Preparation (cont'd)

### *Working With Damaged Foam*



When working with sections of foam that are damaged, the foam can be removed and the remaining undamaged section left in place.

Damaged foams that are not crushed or separated from a part may be saved. When working with original foam:

- remove damaged areas of foam back to an area where the foam is not damaged.
- cover the exposed areas of existing foam with replacement foam. This refills the area where foam originally existed. If additional foam will not be installed, cover the damaged areas of the foam with sound dampening material to keep the foam from absorbing water.

## *Instructor Information*



**Topic B. Installation****B-1*****Foam Provided In New Parts***

Some service parts are supplied with the foam installed. This foam may be a:

- flexible foam material that has been installed in the same locations as the carrier foam used during initial vehicle construction. Some service part assemblies, such as unisides, may have foam installed with carriers between outer panels and inner reinforcements.
- structural foam is used for collision energy management or controlling twisting and flexing of the structure.

***Instructor Information***

An example of a part having flexible foam being added at the factory is the door-opening frame of the 2004 Ford Expedition.

Examples of service parts that contain structural foam are the frame assemblies of the 2003 Ford Crown Victoria (2003 Lincoln Town Car and 2003 Mercury Grand Marquis) and the 2004 Cadillac CTS front lower rails.



B-2

## Topic B. Installation (cont'd)

### Reusing Flexible Foam



When replacing parts with flexible foam between adjacent parts, such as a door skin and an intrusion beam, the foam can be left in place and reused. When using original flexible foam:

- separate the part from the foam using heat. Ensure that the foam does not become damaged during part removal.
- do not reuse foam that is damaged.
- use urethane adhesive or sound dampening material to attach existing material to replacement parts. Small amounts of replacement flexible foam can be used for reattaching foam.

## Instructor Information

### Objectives Worksheet

When replacing parts with flexible foam between adjacent parts, such as a door skin and an intrusion beam, the foam can be left in place and reused. When using original flexible foam:

- separate the part from the foam using heat. Ensure that the foam does not become damaged during part removal.
- do not reuse foam that is damaged.
- use urethane adhesive or sound dampening material to attach existing material to replacement parts.



B-3

## Topic B. Installation (cont'd)

### Installing Foam



When installing foam:

- locate access holes where material can be installed into the part. Do not drill access holes into a part unless directed to do so by the vehicle maker.
- have an estimate of how much material should be installed in the part.
- select the appropriate material for the application and use the appropriate dispenser.
- purge the air from the tubes and level the plungers. This should be done while the cartridge is held with the dispensing end up. For some foam materials, the cartridge cannot be held horizontally because the material is too thin and will run out of the tubes.

## Instructor Information

### Objectives Worksheet

When installing foam:

- locate access holes where material can be installed into the part.
- have an estimate of how much material should be installed in the part.
- select the appropriate material for the application and use the appropriate dispenser.
- purge the air from the tubes and level the plungers. This should be done while the cartridge is held with the dispensing end up.



B-4

## Topic B. Installation (cont'd)



When installing foam:

- install the mixing nozzle on the cartridge. Use only the nozzle supplied by the product maker for the material being used. These nozzles are shipped with the product and may mix foam at a different rate than adhesives or sealers. Using the incorrect mixing nozzle may over- or under-mix the product. Over-mixing the product may cause it to begin expanding in the mixing tip, and under-mixing the product will cause the product to inadequately expand.
- mark the applicator gun for how much material should be dispensed to adequately fill the area.

## Instructor Information

### Objectives Worksheet

When installing foam:

- install the mixing nozzle on the cartridge. Use only the nozzle supplied by the product maker for the material being used. These nozzles are shipped with the product and may mix foam at a different rate than adhesives or sealers. Using the incorrect mixing nozzle may over or under mix the product.
- mark the applicator gun for how much material should be dispensed to adequately fill the area.



B-5

## Topic B. Installation (cont'd)

### *Positioning Replacement Foam*

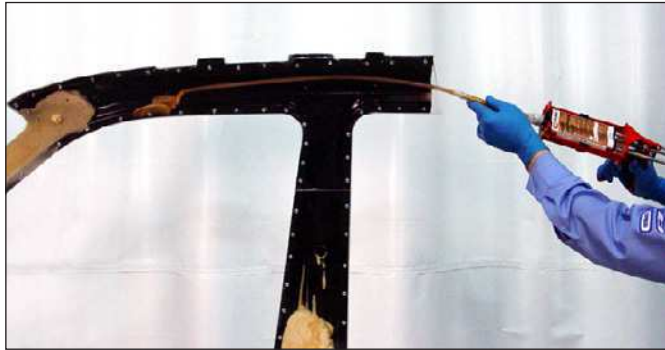

Foam may require positioning in specific areas. When installing foam:

- the relationship between the access hole and final location of the foam must be considered. The flow rate and foam time of the material being used is also a consideration. To position foam in the proper location, all of these variables must be equally considered.
- dams may be required to retain the foam at the intended location. This may be useful when working with a material that has a high flow rate and slow foam time and requires positioning midway in a part.
- extension hoses on the foam nozzle may be required if a material with a fast foam time and slow flow rate requires positioning away from the access hole. Using an extension hose will allow the material to be dispensed directly to its final location.

## *Instructor Information*

### *Objectives Worksheet*

Foam may require positioning in specific areas. When installing foam:

- the relationship between the access hole and final location of the foam must be considered.
- dams may be required to retain the foam at the intended location.
- extension hoses on the foam nozzle may be required if a material with a fast foam time and slow flow rate requires positioning away from the access hole.
- the technique used to dispense the material needs to be considered. A pillar foam with a high flow rate and slow foam time can be dispensed quickly and allowed to run into the bottom of a pillar before expanding. To suspend foam in a part, the product can be dispensed slowly and allowed to foam as it leaves the nozzle. This technique keeps the material from running down the part and away from the intended location. If the dispense rate is too slow, the foam may begin to expand and cure in the mixing tip.

**Topic B. Installation (cont'd)**

- the technique used to dispense the material needs to be considered. A pillar foam with a high flow rate and slow foam time can be dispensed quickly and allowed to run into the bottom of a pillar before expanding. To suspend foam in a part, the product can be dispensed slowly and allowed to foam as it leaves the nozzle. This technique keeps the material from running down the part and away from the intended location. If the dispense rate is too slow, the foam may begin to expand and cure in the mixing tip.

*Instructor Information*

## Topic B. Installation (cont'd)



B-6

### Creating Dams

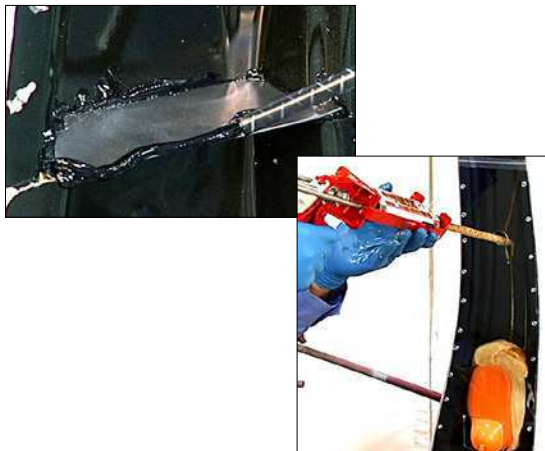

When making a dam to retain foam, various materials can be used. These materials include:

- steel, plastic, or foam blocks for making solid dams. If steel dams are used, ensure they are adequately corrosion protected. To secure solid dams in place, a urethane adhesive or sound dampening material can be used. If a solid foam material is being used, ensure the material will not retain moisture.
- compressible foam, balloons, or two-part foam for making soft dams. Foam blocks can be compressed to fit through small access holes to expand and block an area after final part assembly. Only use foam blocks that are specified by a vehicle maker for this purpose, or materials that will not retain water. Ford Motor Company specifies a compressible foam block as a dam in TSB#01-21-9. Balloons can also be installed and inflated through access holes after final part assembly. If a balloon is used, deflate and remove the balloon before the vehicle is returned to the customer. If two-part foam is used, reuse undamaged pieces of foam and secure them in place with urethane adhesive or sound dampening material.

Some dams may require fitting into parts before final assembly.

## Instructor Information

### Objectives Worksheet

When making a dam to retain foam, various materials can be used. These materials include:

- solid dams such as steel, plastic, or foam blocks.
- soft dams such as compressible foam, balloons, or two-part foam.

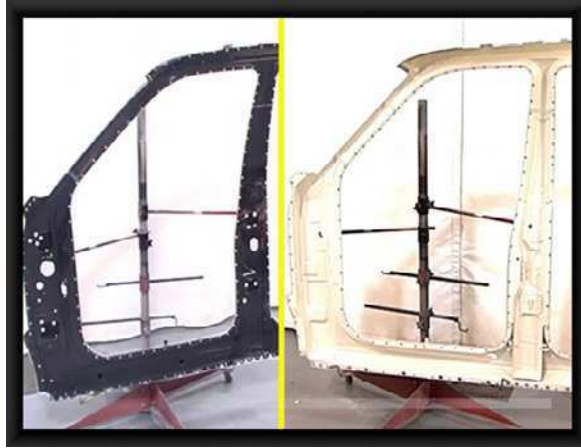
**Topic B. Installation (cont'd)****B-7v*****Video: Making And Installing Dams***

This video shows ways of making and installing dams to retain foam.

---

*Instructor Information*

---





B-8

## Topic B. Installation (cont'd)

### Expansion Rate Variables

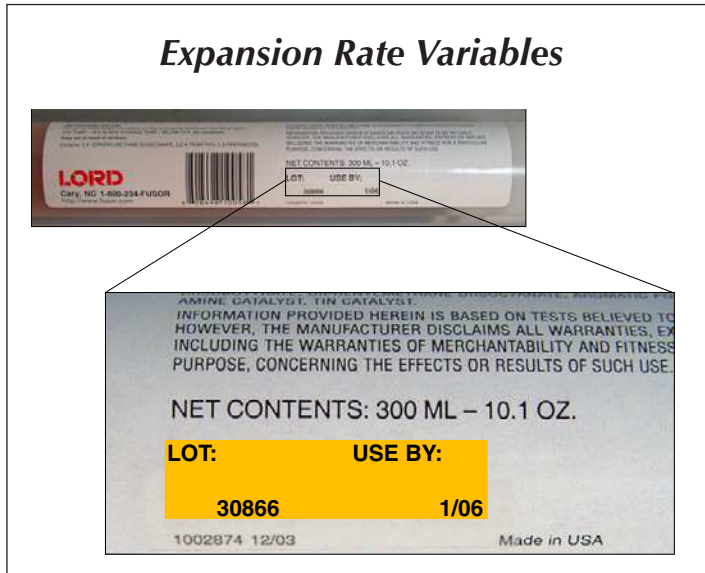

Foam product makers typically identify the expansion rates of material to be about 10 times the liquid volume. This expansion rate can be affected by:

- the shelf life of the product. If the product is expired, it may not function the same as fresh product.
- the rate it is dispensed. If a material is dispensed very quickly, the expansion rate may be less than if the material is dispensed at a rate where the material is just beginning to expand as it leaves the mixing tip.
- temperature. If the part or material is cold, the expansion of the material will be less than a material that is at room temperature. Room temperature is between 21–24° C (70–75° F). Also, a material that is heated to 38° C (100° F) or above will expand more than a material dispensed at room temperature.
- chemical design. Depending on chemistry, the material will only expand as it designed.

## Instructor Information

### Objectives Worksheet

Expansion rate can be affected by:

- shelf life of the product.
- the rate it is dispensed.
- temperature. If the part or material is cold, the expansion of the material will be less than a material that is at room temperature.
- chemical design. Depending on chemistry, the material will only expand as it designed.

**Topic B. Installation (cont'd)**

The advertised maximum expansion rate of a material may have been determined for each material under different conditions.

**EXPANSION SAMPLES**

---

*Instructor Information*

---

**Topic B. Installation (cont'd)**



**B-9v**

**Video: Expansion Of Foam**



This video shows how temperature and dispense rate affects the expansion of foam.

*Instructor Information*

**B-10****Topic B. Installation (cont'd)*****Suspending Foam Without Dams***

To suspend foam in a part without the use of a dam:

- dispense the material slowly. By doing this, the foam will begin to expand as it leaves the mixing tip. When the foam contacts the side of the part, it will fill the area faster and drop less because the material has changed from a liquid to a solid.
- a material that has minimal flow rate will help keep the material in the appropriate location. Foam may flow down fast or drop in vertical parts if not dispensed correctly.

***Instructor Information***

**Topic C. Part-Specific Considerations****C-1*****Area With Limited Or No Access***

When installing foam in areas with limited or no access:

- do not drill access holes into the part unless directed by the vehicle maker. In TSB#01-21-9, Ford says to drill an access hole in a crossmember.
- one method is to install the foam in the part before it is installed on the vehicle. Test fit the part and cut the foam to fit into position. After trimming, use urethane adhesive or small amounts of flexible foam to attach the foam to the vehicle body.

***Instructor Information***

### Topic C. Part-Specific Considerations (cont'd)



C-2

#### *Applying Foam To Door Skins*



When applying foam to door skins:

- apply the foam to the area between the door skin and the intrusion beam before the door is attached to the vehicle.
- apply the foam while the door is horizontal. This will help keep the foam in the intended location. Though typically applied to a horizontal part, foam can be applied to a vertical part when dispensing the material slowly.
- flexible foam is the most common material used. If undamaged foam is being reused, reattach it using small amounts of flexible foam.
- overfilling the area could distort the panel.

#### *Instructor Information*

#### *Objectives Worksheet*

When applying foam to door skins:

- apply the foam to the area between the door skin and the intrusion beam before the door is attached to the vehicle.
- apply the foam while the door is horizontal.
- flexible foam is the most common material used. If undamaged foam is being reused, reattach it using small amounts of flexible foam.
- overfilling the area could distort the panel.

### Topic C. Part-Specific Considerations (cont'd)



C-3

#### *Applying Foam To Roof Skin Bows*

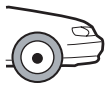

When applying foam to roof skin bows, leave undamaged foam in place whenever possible. If existing foam is being reused, it can be reattached using small amounts of flexible foam or urethane adhesive.

If foam is being applied to an installed roof skin, dispense slowly so the material is expanding as it exits the mixing nozzle. Applying foam in this manner helps reduce material overflow as it expands.

When applying foam between the door skin and intrusion beam, overfilling the area could distort the panel.

### *Instructor Information*

#### *Objectives Worksheet*

When applying flexible foam to a roof bow, use a drop cloth to protect the inside of the vehicle from any material that may fall. If foam begins to drip or fall, allow the material to cure before cleaning or trimming.

**Topic C. Part-Specific Considerations (cont'd)****C-4*****Lower Rail Foam***

When working with lower rails:

- the material is typically a structural foam.
- the placement of structural foam is critical.
- the service part may contain the structural foam from the vehicle maker. This is because it may not be possible to install the foam after part installation.
- some vehicle makers allow damaged structural foam to be repaired. If the foam is broken loose, it may be secured in place by adding additional structural foam.

The 2004 Cadillac CTS uses front lower rails that contain structural foam. These front lower rails have the foam installed in the service part. In TSB#01-21-9 Ford says to completely fill areas where structural foam is damaged.

The 2005 Chevrolet SSR has a replaceable structural foam block installed where the A-pillar and rocker panel join. This block is held in place with structural adhesive and the outer hinge pillar is reinstalled using rivets and plug welds.

***Instructor Information***



**Topic C. Part-Specific Considerations (cont'd)****C-5*****Filling Lower Pillar Areas***

When filling lower pillar areas with foam, follow the vehicle maker's recommendations. When installing foam in lower pillars:

- determine how much foam is required so the area is not over- or under-filled.
- dams may be required to hold the foam in the proper location on the vehicle.
- locate access holes for installing the material. Ensure that foam installed into the lower pillar area reaches the bottom of the pillar.

***Instructor Information***

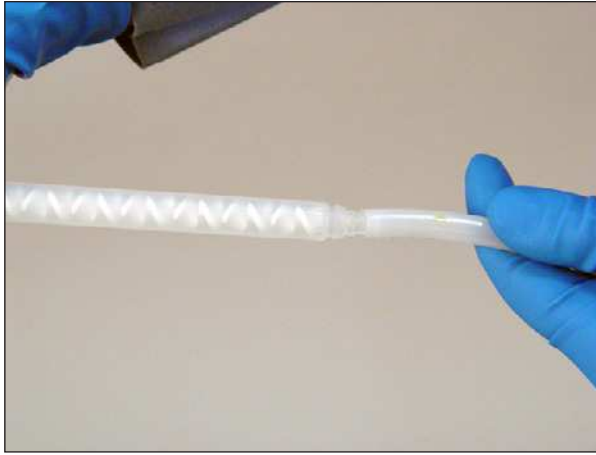
**Topic C. Part-Specific Considerations (cont'd)****C-6*****Filling Lower Pillar Areas (cont'd)***

Techniques for positioning the material in a lower pillar area include using a product with a high flow rate and a slow foam time or attaching an extension hose to the mixing nozzle. This will ensure the material is properly positioned.

***Instructor Information***

**Topic C. Part-Specific Considerations (cont'd)**

C-7

***Suspending Foam In Pillars***

When suspending foam in pillars:

- reuse existing dams whenever possible. If this is possible, it may work best to attach the dam to the vehicle body before attaching the part.
- it may be necessary to make new dams.
- use a dispense technique that allows the material to be positioned where it is applied.

***Instructor Information***

**Topic C. Part-Specific Considerations (cont'd)****C-8*****Horizontal Part***

When installing foam in a horizontal part:

- flexible or rigid NHV material will typically be used.
- dams may be required.
- an extension hose may be required to position the foam properly.

***Instructor Information***

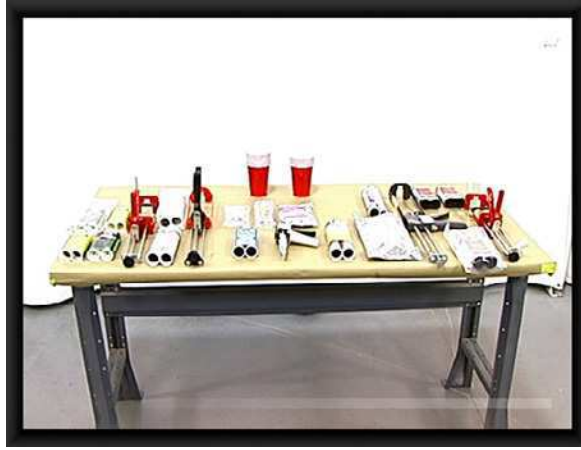

C-9v

**Topic C. Part-Specific Considerations (cont'd)*****Video: Using Foam During Repairs***

This video shows different ways to use foam during repairs.

---

*Instructor Information*

---



C-10v

**Topic C. Part-Specific Considerations (cont'd)*****Video: Reinstalling Structural Foam***

This video shows different ways to use foam during repairs.

---

*Instructor Information*

**Topic C. Conclusion****D-1*****Conclusion***

Topics discussed in this module included:

- tools and techniques used to remove foam.
- new part preparation.
- recycled part preparation.

***Instructor Information***

## Topic C. Conclusion (cont'd)



D-2

### Conclusion (cont'd)

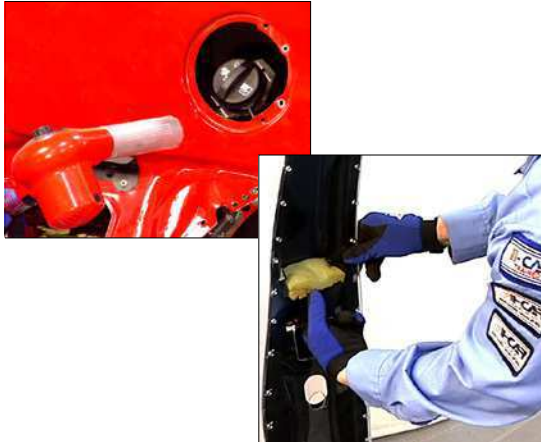

Topics discussed in this module included:

- reattaching foam that is being reused.
- materials used for making foam dams.
- expansion rate variables for foam.



### Instructor Information

#### I-CAR Instructors

You may choose to hand out Quiz #4 at this point for review. The quiz can be printed from the Instructor Preparation portion of this CD-ROM. The quizzes are an optional exercise.

#### Career and Technical School and College Instructors

Quiz #4 should be handed out at this point in the class. The quiz can be printed from the Instructor Preparation portion of this CD-ROM. Students can also print this quiz from their CD-ROM.

Remind the students that the Student CD-ROM includes copies of the:

- Textbook.
- Video Scripts.
- Self-Study Narration Scripts.
- Student Handouts (if applicable).



**Topic C. Conclusion (cont'd)**



D-3

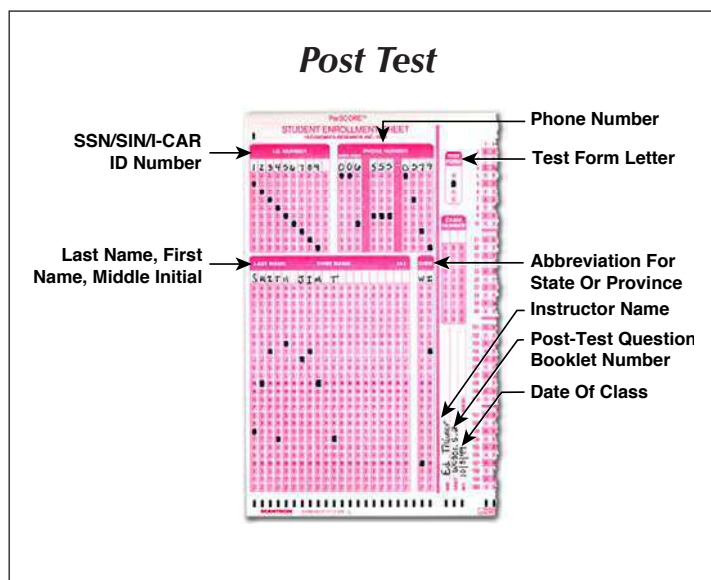

Before beginning the post-test, the answer sheets need to be correctly filled out. Any missing information will delay the issuing of credit for this program. Have the Students clearly fill in their:



- SSN/SIN/I-CAR ID number.
- phone number.
- name, leaving a space between the last and first name, and between their first name and middle initial.
- the two letter abbreviation for the State or Province. This should be filled in under **CODE**.
- test form letter (A, B, C, or D) under **TEST FORM**. The test form letter appears in the upper right corner of the Post-Test Question Booklet.

*Instructor Information*

It is very important that the Students properly fill out the answer sheet before starting the Post-Test.

Select the graphic text for a larger view of each section of the Scantron form that is required to be filled out by the Students.

**Contesting A Question**

All questions contained in this Post-Test have been carefully developed and reviewed. If, however, a Student feels that a question has multiple answers or is incorrect in any way, they still must answer it with what they feel is the best answer. They can then also darken the letter E on the form for that question and write their concern on the back of the form. This is only to alert staff of a Student's concern and does not mean the Student is not responsible for answering the question correctly.

This process is to be used in extreme situations where a Student feels strongly that there is a problem with a question and brings it to the attention of the Instructor/Administrator, and should not be announced to the class.

**Topic C. Conclusion (cont'd)**

The Students also need to clearly write in the:

- Instructor's name on the line appearing after **NAME**.
- Post-Test Question Booklet number on the line appearing after **SUBJECT**. This number is located on the upper left corner of the question booklet after the word **SUBJECT**.
- date of the class on the line appearing after **DATE**.

Direct the Students to answer all questions in the question booklet using the appropriate area on the answer sheet. Use a pencil to darken the circle which represents the best answer to the question. There is only one correct answer for each question.

The answer sheet is electronically scanned, so questions will not be scored as correct if they are:

- answered with more than one answer.
- not clearly marked on the answer sheet.
- mistakenly marked and not completely erased.
- completed in ink.

At the completion of the Post-Test, Students are to hand in both the completed answer sheet and the question booklet. Students are not allowed to keep the question booklets. It is the Post-Test administrator's responsibility to make sure that all test booklets are returned to I-CAR with the answer sheets. Post-Test questions are changed often and printed "on demand," so there is no advantage to keeping the question booklets.

---

*Instructor Information*

---

**Topic C. Conclusion (cont'd)**

Place the Post-Test and the completed answer sheets in the provided envelope and mail them to I-CAR for scoring. Students will be informed of their test results upon scoring of the tests and processing by I-CAR.

*Instructor Information*